

DISCLAIMER: The use of this standard is governed by the "Texas Engineering Practice Act". No warranty of any kind is made by TxDOT for any purpose whatsoever. TxDOT assumes no responsibility for the conversion of this standard to other formats or for incorrect results or damages resulting from its use.

DATE: FILE:

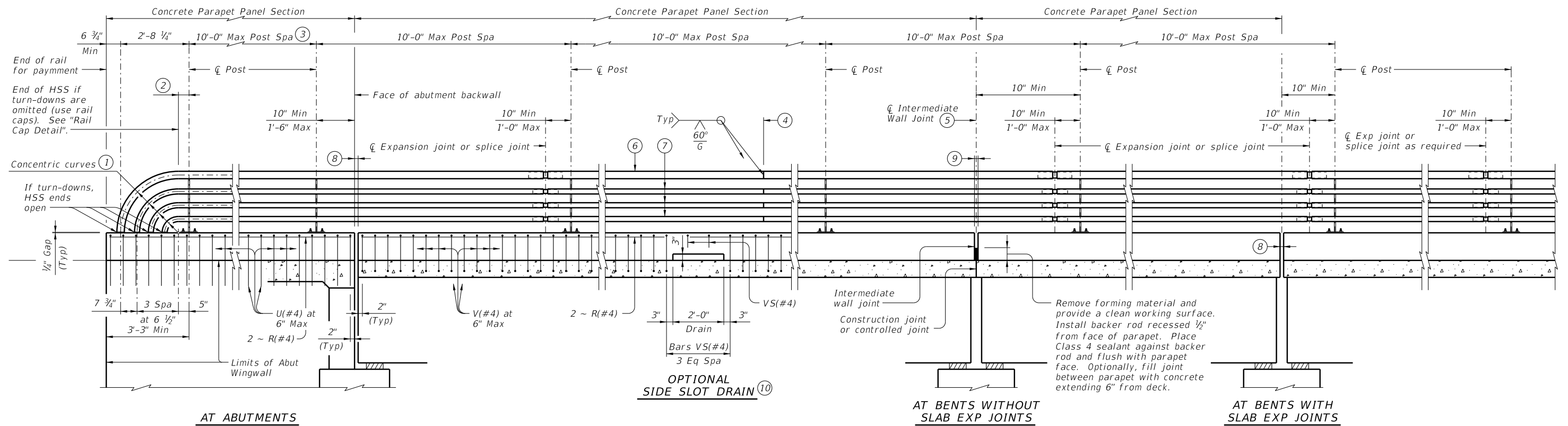

**ROADWAY ELEVATION OF RAIL**

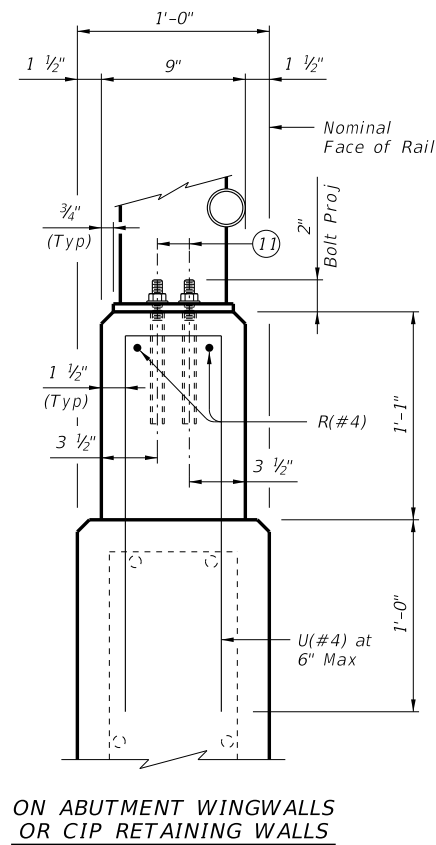
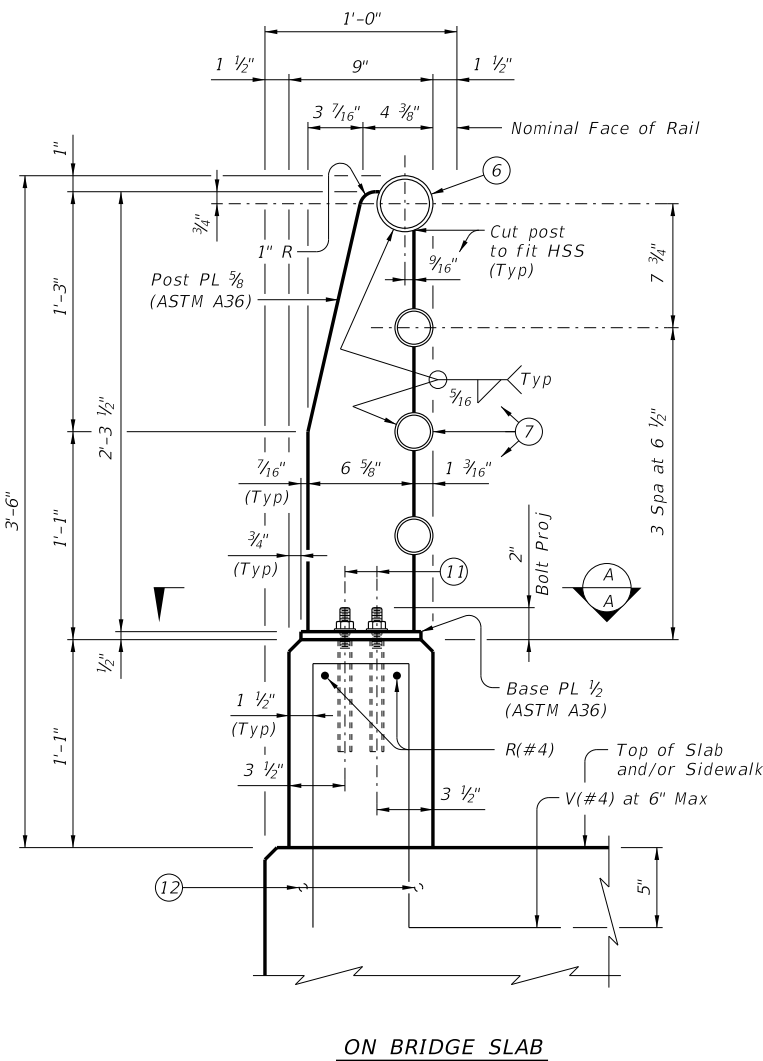

**SECTIONS THRU RAIL**

- ① Portion of railing with turn-downs to be used or omitted as indicated on Bridge Layout.
- ② 10" Min ~ 1'-6" Max if turn-downs are omitted.
- ③ Min of 2 posts required on wingwall.
- ④ One shop splice per panel is permitted (with minimum 85 percent penetration). The weld may be square groove or single vee groove. Grind smooth.
- ⑤ Provide at all interior bents without slab expansion joints.
- ⑥ HSS 3.500 x 0.216 (Rail Member)
- ⑦ HSS 2.375 x 0.154 (Rail Member)
- ⑧ Same as slab joint opening. (5" Max Expansion Joint)
- ⑨ Opening 1/4" Min, 3/4" Max.
- ⑩ Drains may be used where shown elsewhere on the plans or as directed by the Engineer. Do not place drains over railroad tracks, lower roadways, or sidewalks. When side slot drains are used, provide 3'-0" Min clear spacing between drains slots and center bents or joint locations with a 8'-0" Min clear spacing between drain slots.
- ⑪ center anchor bolts. See "Material Notes" for anchor bolt information.
- ⑫ Top longitudinal slab bar may be adjusted laterally 3" plus or minus to tie reinforcing.

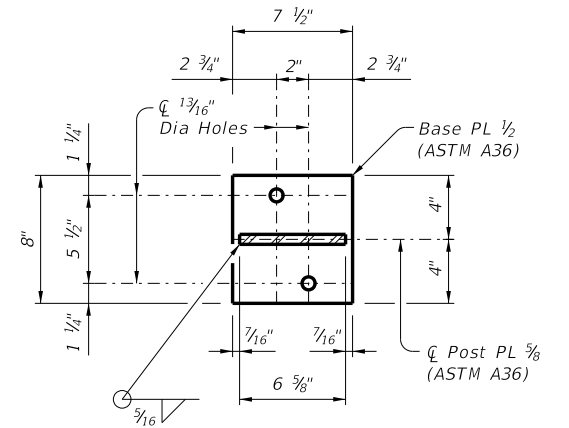

**SECTION A-A**  
Showing base plate detail.

SHEET 1 OF 2

		<b>Bridge Division Standard</b>	
<h1>PEDESTRIAN RAIL</h1>			
<h2>TYPE PR22</h2>			
FILE: r1std029-18.dgn	DN: TAR	CK: TBE	DW: JTR
©TxDOT March 2018	CONT	SECT	JOB
REVISIONS		HIGHWAY	
DIST		COUNTY	
		SHEET NO.	

DISCLAIMER: The use of this standard is governed by the "Texas Engineering Practice Act". No warranty of any kind is made by TxDOT for any purpose whatsoever. TxDOT assumes no responsibility for the conversion of this standard to other formats or for incorrect results or damages resulting from its use.

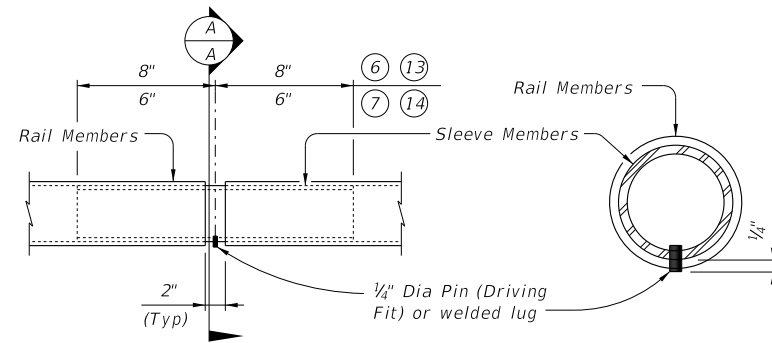

**AT SPLICES OR EXP JTS** **SECTION A-A**  
**PIPE SPLICE DETAIL**

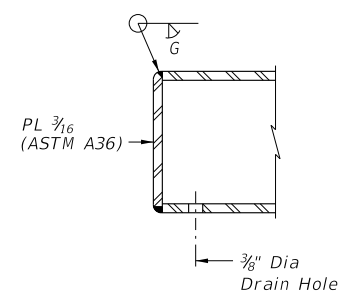

**RAIL CAP DETAIL**

- ⑥ HSS 3.500 x 0.216 (Rail Member)
- ⑦ HSS 2.375 x 0.154 (Rail Member)
- ⑬ HSS 2.875 x 0.203 (Sleeve Member)
- ⑭ HSS 1.900 x 0.145 (Sleeve Member)

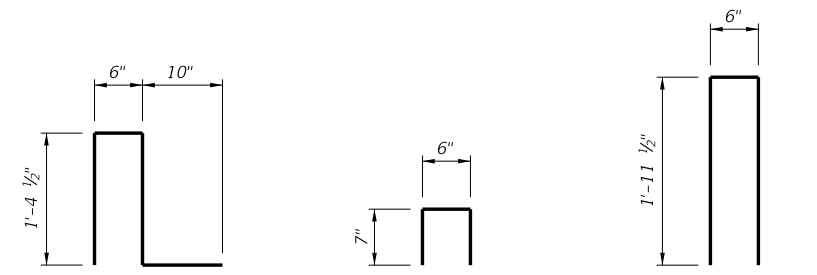

**BARS V (#4)** **BARS VS (#4)** **BARS U (#4)**

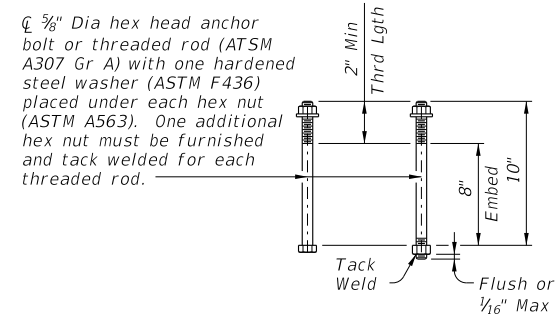

**CAST-IN-PLACE ANCHOR BOLT OPTIONS**

**CONSTRUCTION NOTES:**  
 This rail may be slip-formed if approved by the Engineer when epoxy adhesive anchor bolts are used.  
 Slip-forming parapet is not allowed if anchor bolts are cast with parapet wall.  
 At the Contractor's option anchor bolts may be cast with the parapet. See "Material Notes".  
 Panel lengths of railing must be attached to a minimum of three posts except on abutment wingwalls.  
 Test adhesive anchors in accordance with Item 450.3.3, "Tests". Test 3 anchors per 100 anchors installed. Perform corrective measures to provide adequate capacity if any of the tests do not meet the required test load. Repair damage from testing as directed.  
 Face of rail, posts and parapet must be vertical transversely unless otherwise approved. Rail posts must be perpendicular to top of adjacent concrete parapet grade. Use Type VIII epoxy mortar under post base plates if gaps larger than 1/16" exist.  
 For curved railing applications, fabricate the HSS rail to the radius when the radius is 600' or less. Submit shop drawings for approval when tubes are required to be fabricated to a radius. Shop drawings must be submitted to the Engineer for approval.  
 Round or chamfer all exposed edges of steel components 1/16" by grinding prior to galvanizing.  
 Chamfer all exposed concrete corners.

**MATERIAL NOTES:**  
 Provide ASTM A500 Gr B, A1085 or A53 Gr B for all HSS.  
 Galvanize all metal components of steel rail system. Apply additional coatings when shown elsewhere on the plans. When plans require paint over galvanizing, follow the requirements for painting galvanized steel in Item 445, "Galvanizing" and when field painting, Item 446, "Field Cleaning and Painting Steel". Sleeve members and anchor bolts must receive galvanization prior to installation and only field paint after installation unless directed otherwise by Engineer.  
 Anchor bolts must be 5/8" Dia ASTM A307 Gr A fully threaded rods with one hex nut and one hardened steel washer (ASTM F436). Nuts must conform to ASTM A563 requirements. Embed fully threaded rods into parapet using a Type III, Class C, D, E, or F anchor adhesive. Minimum adhesive anchor embedment depth is 7". Anchor adhesive chosen must be able to achieve a nominal bond strength in tension of a single anchor, Na, 8.5 kips (edge distance must be accounted for). Submit signed and sealed calculations or the manufacturer's published literature showing the proposed anchor adhesive's ability to develop this load to the Engineer for approval prior to use. Anchor installation, including hole size, drilling, and clean out, must be in accordance with Item 450, "Railing".  
 Optional cast-in-place anchor bolts must be 5/8" Dia ASTM A307 Gr A with one hardened steel washer (ASTM F436) placed under each hex nut or ASTM A307 Gr A threaded rods with one tack welded hex nut each and with one hex nut with one hardened steel washer (ASTM F436) each. Nuts must conform to ASTM A563 requirements.  
 Provide Class "C" concrete. Provide Class "C" (HPC) if required elsewhere.  
 Epoxy coat or galvanize all reinforcing if slab bars are epoxy coated or galvanized.  
 Provide Grade 60 reinforcing steel.  
 Deformed Welded Wire Reinforcement (WWR) (ASTM A1064) of equal size and spacing may be substituted for Bars U, and V unless noted otherwise.  
 Provide bar laps, where required, as follows:  
 Uncoated or galvanized ~ #4 = 1'-7"  
 Epoxy coated ~ #4 = 2'-5"

**GENERAL NOTES:**  
 Designed according to AASHTO LRFD Specifications.  
 Do not use this railing on bridges with expansion joints providing more than 5" movement.  
 Rail anchorage details shown on this standard may require modification for select structure types. See appropriate details elsewhere in plans for these modifications.  
 For all rails, submit erection drawings showing section lengths, splice locations, rail post spacing and anchor bolt setting for approval.  
 Average weight of railing: 146 plf ~ total  
 122 plf ~ Conc (with no Overlay)  
 24 plf ~ Steel

Cover dimensions are clear dimensions, unless noted otherwise.  
 Reinforcing bar dimensions shown are out-to-out of bar.

**Bridge Division Standard**

**PEDESTRIAN RAIL**

**TYPE PR22**

FILE: r1std029-18.dgn	DN: TAR	CK: TBE	DW: JTR	CK: TAR
©TxDOT March 2018	CONT	SECT	JOB	HIGHWAY
REVISIONS				
	DIST	COUNTY	SHEET NO.	

DATE:  
 FILE: