



**Standard
Specifications
for Construction
and Maintenance of
Highways, Streets,
and Bridges**

**Adopted by the
Texas Department of Transportation**

November 1, 2014

Published in November 2014. This document has been created to further the purposes of §201.053(b)(7) Texas Transportation Code to maximize federal funding for highways, public transportation, and aviation purposes, and to help the Department achieve its performance measures set out in the General Appropriations Act (GAA), S.B. 1, 83rd Texas Legislature, Regular Session, 2013. This publication has been filed with the State Publications Clearinghouse in the State Library in accordance with the Texas State Depository Law.



Foreword

To purchase a copy of this book, go to the Department's web page, <http://www.txdot.gov>, Support Services Division, or call the Department's Support Services Division.

For additional information on specifications or information on Departmental Materials Specifications (DMS), Material Producer Lists (MPL), Test Procedures, Material Inspection Guide, and other materials information, go to <http://www.txdot.gov>.

OUTLINE OF SPECIFICATIONS

Each specification is outlined by Articles and Sections. The basic Articles required for a specification are:

1. **DESCRIPTION**
2. **MATERIALS**
3. **EQUIPMENT**
4. **CONSTRUCTION OR WORK METHODS**
5. **MEASUREMENT**
6. **PAYMENT**

Some Articles are not used in every Item. Measurement and Payment Articles are combined when the work described is subsidiary to bid Items of the Contract.

HIERARCHY OF ORGANIZATIONAL ELEMENTS

Here "XXX" represents the Item number. The hierarchy of organizational elements available below the Item level is as follows:

XXX.1., Article
XXX.1.1., Section
XXX.1.1.1., Section
XXX.1.1.1.1., Section
XXX.1.1.1.1.1., Section
XXX.1.1.1.1.1.1., Section

The term Section is used for all breaks below the Article.

This page intentionally left blank

Table of Contents



ITEMS 1-9		GENERAL REQUIREMENTS AND COVENANTS	1
Item	1	Abbreviations and Definitions	3
	2	Instructions to Bidders	14
	3	Award and Execution of Contract	21
	4	Scope of Work	25
	5	Control of the Work	30
	6	Control of Materials	36
	7	Legal Relations and Responsibilities	41
	8	Prosecution and Progress	52
	9	Measurement and Payment	61
100 ITEMS		EARTHWORK AND LANDSCAPE	67
Item	100	Preparing Right of Way	69
	103	Disposal of Wells	71
	104	Removing Concrete	73
	105	Removing Treated and Untreated Base and Asphalt Pavement	74
	106	Obliterating Abandoned Road	75
	110	Excavation	76
	112	Subgrade Widening	78
	132	Embankment	80
	134	Backfilling Pavement Edges	84
	150	Blading	86
	152	Road Grader Work	87
	154	Scraper Work	88
	156	Bulldozer Work	89
	158	Specialized Excavation Work	90
	160	Topsoil	91
	161	Compost	93
	162	Sodding for Erosion Control	95
	164	Seeding for Erosion Control	97
	166	Fertilizer	105
	168	Vegetative Watering	106
	169	Soil Retention Blankets	107
	170	Irrigation System	108
	180	Wildflower Seeding	111
	192	Landscape Planting	112
	193	Landscape Establishment	117
200 ITEMS		SUBGRADE TREATMENTS AND BASE	119
Item	204	Sprinkling	121
	210	Rolling	122
	216	Proof Rolling	125
	247	Flexible Base	126
	251	Reworking Base Courses	132

Table of Contents (continued)

260	Lime Treatment (Road-Mixed).....	136
263	Lime Treatment (Plant-Mixed).....	142
265	Fly Ash or Lime-Fly Ash Treatment (Road-Mixed).....	147
275	Cement Treatment (Road-Mixed).....	153
276	Cement Treatment (Plant-Mixed).....	158
292	Asphalt Treatment (Plant-Mixed).....	163
<hr/>		
300 ITEMS	SURFACE COURSES AND PAVEMENTS	171
Item 300	Asphalts, Oils, and Emulsions.....	173
301	Asphalt Antistripping Agents.....	184
302	Aggregates for Surface Treatments	186
305	Salvaging, Hauling, and Stockpiling Reclaimable Asphalt Pavement	189
310	Prime Coat	190
314	Emulsified Asphalt Treatment.....	192
315	Fog Seal	194
316	Seal Coat.....	195
320	Equipment for Asphalt Concrete Pavement.....	200
330	Limestone Rock Asphalt Pavement.....	204
334	Hot-Mix Cold-Laid Asphalt Concrete Pavement	207
340	Dense-Graded Hot-Mix Asphalt (Small Quantity).....	214
341	Dense-Graded Hot-Mix Asphalt.....	230
342	Permeable Friction Course.....	258
344	Superpave Mixtures.....	274
346	Stone-Matrix Asphalt	302
347	Thin Overlay Mixtures.....	330
348	Thin Bonded Friction Courses	349
350	Microsurfacing	368
351	Flexible Pavement Structure Repair	374
354	Planing and Texturing Pavement	377
356	Fabric Underseal	379
358	Hot In-Place Recycling of Asphalt Concrete Surfaces.....	382
360	Concrete Pavement.....	389
361	Repair of Concrete Pavement	400
<hr/>		
400 ITEMS	STRUCTURES	403
Item 400	Excavation and Backfill for Structures	405
401	Flowable Backfill.....	414
402	Trench Excavation Protection.....	416
403	Temporary Special Shoring	417
404	Driving Piling	418
405	Foundation Load Test.....	424
406	Timber Piling	425
407	Steel Piling	427
409	Prestressed Concrete Piling	430
410	Soil Nail Anchors	432
411	Rock Nail Anchors	436
416	Drilled Shaft Foundations	440
420	Concrete Substructures.....	447
421	Hydraulic Cement Concrete	463
422	Concrete Superstructures.....	479

Table of Contents (continued)

423	Retaining Walls.....	495
424	Precast Concrete Structural Members (Fabrication)	502
425	Precast Prestressed Concrete Structural Members	518
426	Post-Tensioning.....	521
427	Surface Finishes for Concrete	524
428	Penetrating Concrete Surface Treatment.....	530
429	Concrete Structure Repair.....	532
431	Pneumatically Placed Concrete.....	534
432	Riprap.....	539
434	Bridge Bearings.....	544
438	Cleaning and Sealing Joints	553
439	Bridge Deck Overlays.....	555
440	Reinforcement for Concrete	564
441	Steel Structures.....	572
442	Metal for Structures	585
445	Galvanizing.....	590
446	Field Cleaning and Painting Steel	593
447	Structural Bolting.....	602
448	Structural Field Welding	607
449	Anchor Bolts	621
450	Railing	624
451	Retrofit Railing.....	628
454	Bridge Expansion Joints	630
458	Waterproofing Membranes for Structures	632
459	Gabions and Gabion Mattresses	636
460	Corrugated Metal Pipe.....	639
461	Structural Plate Structures.....	646
462	Concrete Box Culverts and Drains	650
464	Reinforced Concrete Pipe	654
465	Junction Boxes, Manholes, and Inlets.....	659
466	Headwalls and Wingwalls.....	663
467	Safety End Treatment.....	665
471	Frames, Grates, Rings, and Covers	668
472	Removing and Re-Laying Culvert.....	670
474	Linear Drains	672
476	Jacking, Boring, or Tunneling Pipe or Box	675
479	Adjusting Manholes and Inlets.....	678
480	Cleaning Existing Culverts.....	680
481	Pipe for Drains.....	681
483	Concrete Bridge Deck Surfacing	683
490	Timber Structures	686
491	Timber for Structures.....	688
492	Timber Preservative and Treatment	690
495	Raising Existing Structures.....	692
496	Removing Structures	694
497	Sale of Salvageable Material.....	696
499	Adjusting Steel Shoes	697

Table of Contents (continued)

	500 ITEMS	MISCELLANEOUS CONSTRUCTION.....	699
Item	500	Mobilization	701
	502	Barricades, Signs, and Traffic Handling	703
	504	Field Office and Laboratory	705
	506	Temporary Erosion, Sedimentation, and Environmental Controls	707
	508	Constructing Detours.....	719
	510	One-Way Traffic Control.....	721
	512	Portable Traffic Barrier	722
	514	Permanent Concrete Traffic Barrier.....	725
	520	Weighing and Measuring Equipment.....	727
	528	Colored Textured Concrete and Landscape Pavers.....	729
	529	Concrete Curb, Gutter, and Combined Curb and Gutter	733
	530	Intersections, Driveways, and Turnouts	735
	531	Sidewalks	737
	533	Milled Rumble Strips.....	739
	536	Concrete Medians and Directional Islands	740
	538	Right of Way Markers	742
	540	Metal Beam Guard Fence	743
	542	Removing Metal Beam Guard Fence	747
	543	Cable Barrier System	748
	544	Guardrail End Treatments	750
	545	Crash Cushion Attenuators	751
	550	Chain Link Fence.....	753
	552	Wire Fence	758
	556	Pipe Underdrains.....	760
	560	Mailbox Assemblies.....	763
	585	Ride Quality for Pavement Surfaces	764
<hr/>			
	600 ITEMS	LIGHTING, SIGNING, MARKINGS, AND SIGNALS	769
Item	610	Roadway Illumination Assemblies	771
	613	High Mast Illumination Poles	775
	614	High Mast Illumination Assemblies.....	778
	616	Performance Testing of Lighting Systems.....	780
	617	Temporary Roadway Illumination	781
	618	Conduit.....	783
	620	Electrical Conductors.....	785
	621	Tray Cable.....	787
	622	Duct Cable.....	788
	624	Ground Boxes	790
	625	Zinc-Coated Steel Wire Strand.....	792
	627	Treated Timber Poles.....	793
	628	Electrical Services	795
	636	Signs	797
	643	Sign Identification Decals	800
	644	Small Roadside Sign Assemblies.....	802
	647	Large Roadside Sign Supports and Assemblies	805
	650	Overhead Sign Supports	808
	654	Sign Walkways	812
	656	Foundations for Traffic Control Devices	814
	658	Delineator and Object Marker Assemblies	816

Table of Contents (continued)

662	Work Zone Pavement Markings	818
666	Retroreflectorized Pavement Markings	821
668	Prefabricated Pavement Markings	827
672	Raised Pavement Markers	829
677	Eliminating Existing Pavement Markings and Markers	832
678	Pavement Surface Preparation for Markings	834
680	Highway Traffic Signals	836
681	Temporary Traffic Signals	839
682	Vehicle and Pedestrian Signal Heads	841
684	Traffic Signal Cables	843
685	Roadside Flashing Beacon Assemblies	846
686	Traffic Signal Pole Assemblies (Steel)	849
687	Pedestal Pole Assemblies	852
688	Pedestrian Detectors and Vehicle Loop Detectors	854
690	Maintenance of Traffic Signals	857
<hr/>		
700 ITEMS	MAINTENANCE	863
Item 700	Pothole Repair	865
712	Cleaning and Sealing Joints and Cracks (Asphalt Concrete)	867
713	Cleaning and Sealing Joints and Cracks (Concrete Pavement)	869
720	Repair of Spalling in Concrete Pavement	871
721	Fiber Reinforced Polymer Patching Material	873
730	Roadside Mowing	876
731	Herbicide Treatment	878
734	Litter Removal	881
735	Debris Removal	882
738	Cleaning and Sweeping Highways	884
740	Graffiti Removal and Anti-Graffiti Coating	886
745	Picnic Area Maintenance	888
751	Landscape Maintenance	890
752	Tree and Brush Removal	892
760	Cleaning and Reshaping Ditches	894
764	Pump Station and Drainage System Cleaning	895
770	Guard Fence Repair	897
771	Repair Cable Barrier System	900
772	Post and Cable Fence	902
774	Attenuator Repair	904
776	Metal Rail Repair	905
778	Concrete Rail Repair	906
780	Concrete Crack Repair	908
784	Steel Member Repair	909
785	Bridge Joint Repair or Replacement	912
786	Carbon Fiber Reinforced Polymer	914
788	Concrete Beam Repair	917
789	Treatment for ASR-Affected Concrete	918

This page intentionally left blank

Items 1–9

General Requirements and Covenants

This page intentionally left blank

Item 1

Abbreviations and Definitions



1. APPLICABILITY

Wherever the following terms are used in these specifications or other Contract documents, the intent and meaning will be interpreted as shown below.

2. ABBREVIATIONS

AAR	Association of American Railroads
AASHTO	American Association of State Highway and Transportation Officials
ACI	American Concrete Institute
ACPA	American Concrete Pipe Association
AI	Asphalt Institute
AIA	American Institute of Architects
AISC	American Institute of Steel Construction
AISI	American Iron and Steel Institute
AITC	American Institute of Timber Construction
ALSC	American Lumber Standard Committee, Inc.
AMRL	AASHTO Materials Reference Laboratory
ANLA	American Nursery and Landscape Association
ANSI	American National Standards Institute
APA	The Engineered Wood Association
API	American Petroleum Institute
APWA	American Public Works Association
AREMA	American Railway Engineering and Maintenance-of-Way Association
ASBI	American Segmental Bridge Institute
ASCE	American Society of Civil Engineers
ASLA	American Society of Landscape Architects
ASME	American Society of Mechanical Engineers
ASNT	American Society for Nondestructive Testing
ASTM	American Society for Testing and Materials
AWC	American Wood Council
AWG	American Wire Gage
AWPA	American Wood Protection Association
AWPI	American Wood Preservers Institute
AWS	American Welding Society
AWWA	American Water Works Association
BMP	Best Management Practices
CFR	Code of Federal Regulations
CMP	Corrugated Metal Pipe
COE	U.S. Army Corps of Engineers
CRSI	Concrete Reinforcing Steel Institute
DBE	Disadvantaged Business Enterprise
DMS	Departmental Material Specification
EIA	Electronic Industries Alliance
EPA	United States Environmental Protection Agency
FHWA	Federal Highway Administration, U.S. Department of Transportation
FSS	Federal Specifications and Standards (General Services Administration)
GSA	General Services Administration
HUB	Historically Underutilized Business
ICEA	Insulated Cable Engineers Association

IEEE	Institute of Electrical and Electronics Engineers
IESNA	Illuminating Engineering Society of North America
IMSA	International Municipal Signal Association
ISO	International Organization for Standardization
ITS	Intelligent Transportation System
ITE	Institute of Transportation Engineers
LRFD	Load and Resistance Factor Design
MASH	Manual for Assessing Safety Hardware
MPL	Material Producer List
NCHRP	National Cooperative Highway Research Program
NCR	Nonconformance Report
NEC	National Electrical Code (Published by NFPA)
NEMA	National Electrical Manufacturers Association
NEPA	National Environmental Policy Act
NESC	National Electrical Safety Code
NFPA	National Fire Protection Association
NIST	National Institute of Standards and Technology
NRM	Nonhazardous Recyclable Material
NRMCA	National Ready Mixed Concrete Association
NSBA	National Steel Bridge Alliance
NTPEP	National Transportation Product Evaluation Program
OSHA	Occupational Safety & Health Administration, U.S. Department of Labor
PCA	Portland Cement Association
PCI	Precast/Prestressed Concrete Institute
PPI	Plastics Pipe Institute
PS&E	Plans, Specifications, and Estimates
PSL	Project-Specific Location
PTI	Post-Tension Institute
QA	Quality Assurance
QC	Quality Control
RCP	Reinforced Concrete Pipe
RPLS	Registered Public Land Surveyor
RRC	Railroad Commission of Texas
SBE	Small Business Enterprise
SFPA	Southern Forest Products Association
SI	International System of Units
SPIB	Southern Pine Inspection Bureau
SSPC	The Society for Protective Coatings
TAC	Texas Administrative Code
TCEQ	Texas Commission on Environmental Quality
TDLR	Texas Department of Licensing and Regulation
TMUTCD	Texas Manual on Uniform Traffic Control Devices
UL	Underwriters Laboratory, Inc.
USC	United States Code
WRI	Wire Reinforcement Institute
WWPA	Western Wood Products Association

3. DEFINITIONS

- 3.1. **Abrasive Blasting.** Spraying blasts of pressurized air combined with abrasive media.
- 3.2. **Actual Cost.** Contractor's actual cost to provide labor, material, equipment, and project overhead necessary for the work.
- 3.3. **Addendum.** Change in proposal forms developed between advertising and bid submittal deadline.

- 3.4. **Additive Alternate.** A bid item contained in a proposal that is not a regular item or a replacement alternate bid item. The additive alternate item(s) include work that may be added to the base bid at the time of letting.
- 3.5. **Advertisement.** The public announcement required by law inviting bids for work to be performed or materials to be furnished.
- 3.6. **Affiliates.** Two or more firms are affiliated if they share common officers, directors, or stockholders; a family member of an officer, director, or stockholder of one firm serves in a similar capacity in another of the firms; an individual who has an interest in, or controls a part of, one firm either directly or indirectly also has an interest in, or controls a part of, another of the firms; the firms are so closely connected or associated that one of the firms, either directly or indirectly, controls or has the power to control another firm; one firm controls or has the power to control another of the firms; or the firms are closely allied through an established course of dealings including, but not limited to the lending of financial assistance.
- 3.7. **Air Blasting.** Spraying blasts of pressurized air free of oil and moisture.
- 3.8. **Air Temperature.** The temperature measured in degrees Fahrenheit (°F) in the shade, not in the direct rays of the sun, and away from artificial heat.
- 3.9. **Anticipated Profit.** Profit for work not performed.
- 3.10. **Apparent Low Bidder.** The Bidder determined to have the numerically lowest total bid as a result of the tabulation of bids by the Department.
- 3.11. **Architect of Record.** A person registered as an architect or licensed as a landscape architect, in accordance with State law, exercising overall responsibility for the design or a significant portion of the design and performs certain Contract administration responsibilities as described in the Contract; or a firm employed by the State to provide professional architectural services.
- 3.12. **Arterial Highway.** A highway used primarily for through traffic and usually on a continuous route.
- 3.13. **Available Bidding Capacity.** The Contractor's approved bidding capacity less uncompleted work on Department Contracts.
- 3.14. **Award.** The Commission's acceptance of a Contractor's bid for a proposed Contract that authorizes the Department to enter into a Contract.
- 3.15. **Bid.** The offer from the Bidder for performing the work described in the proposal.
- 3.16. **Bid Bond.** The security executed by the Contractor and the Surety furnished to the Department to guarantee payment of liquidated damages if the Contractor fails to enter into an awarded Contract.
- 3.17. **Bid Error.** A mathematical mistake made by a Bidder in the unit price entered into the proposal.
- 3.18. **Bidder.** An individual, partnership, limited liability company, corporation, or joint venture submitting a bid for a proposed Contract.
- 3.19. **Bidders Questionnaire.** A prequalification form completed by a prospective Bidder reflecting a Bidder's financial data and experience.
- 3.20. **Bidding Capacity.** The maximum dollar value a Contractor may have under Contract with the Department at any given time.
- 3.21. **Blast Cleaning.** Using one of the blasting methods including, but not limited to water blasting, low-pressure water blasting, high-pressure water blasting, abrasive blasting, water-abrasive blasting, shot blasting, slurry blasting, water injected abrasive blasting, and brush blasting.

- 3.22. **Bridge.** A structure, including supports, erected over a depression or an obstruction (e.g., water, a highway, or a railway) having a roadway or track for carrying traffic or other moving loads, and having an opening measured along the center of the roadway of more than 20 ft. between faces of abutments, spring lines of arches, or extreme ends of the openings for multiple box culverts.
- 3.23. **Brush Blasting.** Sweeping lightly with an abrasive blast to remove loose material.
- 3.24. **Building Contract.** A Contract entered under Transportation Code, Chapter 223, Subchapter A, "Competitive Bids," for the construction or maintenance of a Department building or appurtenance facilities. Building Contracts are considered to be construction Contracts.
- 3.25. **Callout Work.** Contracts, or work items in Contracts, that require a Contractor's response on an as-needed basis (e.g., see Item 351, "Flexible Pavement Structure Repair").
- 3.26. **Certificate of Insurance.** A form approved by the Department covering insurance requirements stated in the Contract.
- 3.27. **Change Order.** Written order to the Contractor detailing changes to the specified work, item quantities or any other modification to the Contract.
- 3.28. **Commission.** The Texas Transportation Commission or authorized representative.
- 3.29. **Concrete Construction Joint.** A joint formed by placing plastic concrete in direct contact with concrete that has attained its initial set.
- 3.30. **Concrete Repair Manual.** Department manual specifying methods and procedures for concrete repair as an extension of the standard specifications.
- 3.31. **ConcreteWorks®.** Department-owned software for concrete heat analysis. Software is available on Department website.
- 3.32. **Construction Contract.** A Contract entered under Transportation Code, Chapter 223, Subchapter A, for the construction, reconstruction, or maintenance of a segment of the State highway system.
- 3.33. **Consultant.** The licensed professional engineer or engineering firm, or the architect or architectural firm, registered in the State of Texas and under Contract to the Department to perform professional services. The consultant may be the Engineer or architect of record or may provide services through and be subcontracted to the Engineer or architect of record.
- 3.34. **Contract.** The agreement between the Department and the Contractor establishing the obligations of the parties for furnishing of materials and performance of the work prescribed in the Contract documents.
- 3.35. **Contract Documents.** Elements of the Contract including, but not limited to the plans, specifications incorporated by reference, special provisions, special specifications, Contract bonds, change orders, and supplemental agreements.
- 3.36. **Contract Time.** The number of working days specified for completion of the work, including authorized additional working days.
- 3.37. **Contractor.** The individual, partnership, limited liability company, corporation, or joint venture and all principals and representatives with which the Contract is made by the Department.
- 3.38. **Controlled Access Highway.** Any highway to or from which access is denied or controlled, in whole or in part, from or to abutting land or intersecting streets, roads, highways, alleys, or other public or private ways.

- 3.39. **Control of Access.** The condition in which the right to access of owners or occupants of abutting land or other persons in connection with a highway is fully or partially controlled by public authority.
- 3.40. **Control Point.** An established point shown on the plans to provide vertical and horizontal references for geometric control for construction.
- 3.41. **Cross-Sections.** Graphic representations of the original ground and the proposed facility, at right angles to the centerline or base line.
- 3.42. **Culvert.** Any buried structure providing an opening under a roadway for drainage or other purposes. Culverts may also be classified as bridges. (See Section 1.3.22., "Bridge.")
- 3.43. **Cycle.** The activity necessary for performing the specified work within the right of way project limits once.
- 3.44. **Daily Road-User Cost.** Damages based on the estimated daily cost of inconvenience to the traveling public resulting from the work.
- 3.45. **Debar (Debarment).** Action taken by the Department or federal government pursuant to regulation that prohibits a person or company from entering into a Contract, or from participating as a subcontractor, or supplier of materials or equipment used in a highway improvement Contract as defined in Transportation Code, Chapter 223, Subchapter A.
- 3.46. **Detour.** A temporary traffic route around a closed portion of a road.
- 3.47. **Department.** The Texas Department of Transportation (TxDOT).
- 3.48. **Departmental Material Specifications.** Reference specifications for various materials published by the Construction Division.
- 3.49. **Direct Traffic Culvert.** Concrete box culvert whose top slab is used as the final riding surface or is to have an overlay or other riding surface treatment.
- 3.50. **Disadvantaged Business Enterprise.** A for-profit small business certified through the Texas Unified Certification Program in accordance with 49 CFR Part 26, that is at least 51% owned by one or more socially and economically disadvantaged individuals, or in the case of a publicly owned business, in which is at least 51% of the stock is owned by one or more socially and economically disadvantaged individuals, and whose management and daily business operations are controlled by one or more of the individuals who own it.
- 3.51. **Divided Highway.** A highway with separate roadways intended to move traffic in opposite directions.
- 3.52. **Easement.** A real property right acquired by one party to use land belonging to another party for a specified purpose.
- 3.53. **Electronic Vault.** The Department's bidding system where electronic bids are stored before bid opening.
- 3.54. **Engineer.** The Chief Engineer of the Department or the authorized representative of the Chief Engineer.
- 3.55. **Expressway.** A divided arterial highway for through traffic with full or partial control of access and generally with grade separations at intersections.
- 3.56. **Family Member.** A family member of an individual is the individual's parent, parent's spouse, step-parent, step-parent's spouse, sibling, sibling's spouse, spouse, child, child's spouse, spouse's child, spouse's child's spouse, grandchild, grandparent, uncle, uncle's spouse, aunt, aunt's spouse, first cousin, or first cousin's spouse.

- 3.57. **Force Account.** Payment for directed work based on the actual cost of labor, equipment, and materials furnished with markups for project overhead and profit.
- 3.58. **Freeway.** An expressway with full control of access.
- 3.59. **Frontage Road.** A local street or road auxiliary to and located along an arterial highway for service to abutting property and adjacent areas and for control of access (sometimes known as a service road, access road, or insulator road).
- 3.60. **Hazardous Materials or Waste.** Hazardous materials or waste include but are not limited to explosives, compressed gas, flammable liquids, flammable solids, combustible liquids, oxidizers, poisons, radioactive materials, corrosives, etiologic agents, and other material classified as hazardous by 40 CFR 261, or applicable state and federal regulations.
- 3.61. **High-Pressure Water Blasting.** Water blasting with pressures between 5,000 and 10,000 psi.
- 3.62. **Highway, Street, or Road.** General terms denoting a public way for purposes of vehicular travel, including the entire area within the right of way. Recommended usage in urban areas is highway or street; in rural areas, highway or road.
- 3.63. **Historically Underutilized Business.** A corporation, sole proprietorship, partnership, or joint venture formed for the purpose of making a profit certified by the Texas Building and Procurement Commission, and 51% owned by one or more persons who are economically disadvantaged because of their identification as members of certain groups, including African Americans, Hispanic Americans, Asian-Pacific Americans, Native Americans, or women, and have a proportionate interest and demonstrate active participation in the control, operation, and management of the business' affairs. Individuals meeting the HUB definition are required to be residents of the State of Texas. Businesses that do not have their primary headquarters in the State of Texas are not eligible for HUB certification.
- 3.64. **Incentive and Disincentive Provisions.** An adjustment to the Contract price of a predetermined amount for each day the work is completed ahead of or behind the specified milestone, phase, or Contract completion dates. The amount of the incentive and disincentive is determined based on estimated costs for engineering, traffic control, delays to the motorists, and other items involved in the Contract.
- 3.65. **Independent Assurance Tests.** Tests used to evaluate the sampling and testing techniques and equipment used in the acceptance program. The tests are performed by the Department and are not used for acceptance purposes.
- 3.66. **Inspector.** The person assigned by the Engineer to inspect for compliance with the Contract any or all parts of the work and the materials used.
- 3.67. **Intelligent Transportation System.** An integrated system that uses video and other electronic detection devices to monitor traffic flows.
- 3.68. **Intersection.** The general area where 2 or more highways, streets, or roads join or cross, including the roadway and roadside facilities for traffic movements within it.
- 3.69. **Island.** An area within a roadway from which vehicular traffic is intended to be excluded, together with any area at the approach occupied by protective deflecting or warning devices.
- 3.70. **Joint Venture.** Any combination of individuals, partnerships, limited liability companies, or corporations submitting a single bid proposal.
- 3.71. **Lane Rental.** A method to assess the Contractor daily or hourly rental fees for each lane, shoulder, or combination of lanes and shoulders taken out of service.

- 3.72. **Letting.** The receipt, opening, tabulation, and determination of the apparent low Bidder.
- 3.73. **Letting Official.** The Executive Director or any Department employee empowered by the Executive Director to officially receive bids and close the receipt of bids at a letting.
- 3.74. **Licensed Professional Engineer.** A person who has been duly licensed by the Texas Board of Professional Engineers to engage in the practice of engineering in the State of Texas; also referred to as a Professional Engineer.
- 3.75. **Limits of Construction.** An area with established boundaries, identified within the highway right of way and easements, where the Contractor is permitted to perform the work.
- 3.76. **Local Street or Road.** A street or road primarily for access to residence, business, or other abutting property.
- 3.77. **Low-Pressure Water Blasting.** Water blasting with pressures between 3,000 and 5,000 psi.
- 3.78. **Major Item.** An item of work included in the Contract that has a total cost equal to or greater than 5% of the original Contract or \$100,000 whichever is less. A major item at the time of bid will remain a major item. An item not originally a major item does not become one through the course of the Contract.
- 3.79. **Manual of Testing Procedures.** Department manual outlining test methods and procedures maintained by the Materials and Pavements Section of the Construction Division.
- 3.80. **Material Producer List.** Department maintained list of approved products.
- 3.81. **Materially Unbalanced Bid.** A bid that generates a reasonable doubt that award to the Bidder submitting a mathematically unbalanced bid will result in the lowest ultimate cost to the State.
- 3.82. **Mathematically Unbalanced Bid.** A bid containing bid prices that do not reflect reasonable actual costs plus a reasonable proportionate share of the Bidder's anticipated profit, overhead costs, and other indirect costs.
- 3.83. **Median.** The portion of a divided highway separating the traffic lanes in opposite directions.
- 3.84. **Milestone Date.** The date that a specific portion of the work is to be completed, before the completion date for all work under the Contract.
- 3.85. **Monolithic Concrete Placement.** The placement of plastic concrete in such manner and sequence to prevent a construction joint.
- 3.86. **National Holidays.** January 1, the last Monday in May, July 4, the first Monday in September, the fourth Thursday in November, and December 24 or December 25.
- 3.87. **Nonhazardous Recyclable Material.** A material recovered or diverted from the nonhazardous waste stream for the purposes of reuse or recycling in the manufacture of products that may otherwise be produced using raw or virgin materials.
- 3.88. **Nonresident Bidder.** A Bidder whose principal place of business is not in Texas. This includes a Bidder whose ultimate parent company or majority owner does not have its principal place of business in Texas.
- 3.89. **Nonresponsive Proposal.** A proposal that does not meet the criteria for acceptance contained in the proposal form.
- 3.90. **Non-Site-Specific Contracts.** Contracts where a geographic region is specified for the work and work orders, with or without plans, detail the limits and work to be performed.

- 3.91. **Notification.** Either written or oral instruction to the Contractor. Voice mail is oral notification.
- 3.92. **Pavement.** That part of the roadway having a constructed surface for the use of vehicular traffic.
- 3.93. **Pavement Structure.** Combination of surface course and base course placed on a subgrade to support the traffic load and distribute it to the roadbed.
- 3.93.1. **Surface Course.** Pavement structure layers designed to accommodate the traffic load. The top layer resists skidding, traffic abrasion, and the disintegrating effects of climate and is sometimes called the wearing course.
- 3.93.2. **Base Course.** One or more layers of specified material thickness placed on a subgrade to support a surface course.
- 3.93.3. **Subgrade.** The top surface of a roadbed upon which the pavement structure, shoulders, and curbs are constructed.
- 3.93.4. **Subgrade Treatment.** Modifying or stabilizing material in the subgrade.
- 3.94. **Payment Bond.** The security executed by the Contractor and the Surety, furnished to the Department to guarantee payment of all legal debts of the Contractor pertaining to the Contract.
- 3.95. **Performance Bond.** The security executed by the Contractor and the Surety, furnished to the Department to guarantee the completion of the work in accordance with the terms of the Contract.
- 3.96. **Plans.** The drawings approved by the Engineer, including true reproductions of the drawings that show the location, character, dimensions, and details of the work and are a part of the Contract.
- 3.97. **Power of Attorney for Surety Bonds.** An instrument under corporate seal appointing an attorney-in-fact to act on behalf of a Surety in signing bonds.
- 3.98. **Prequalification.** The process for determining a Contractor's eligibility to bid work.
- 3.99. **Prequalification Statement.** The forms on which required information is furnished concerning the Contractor's ability to perform and finance the work.
- 3.100. **Project-Specific Location.** A material source, plant, waste site, parking area, storage area, field office, staging area, haul road, or other similar location either outside the project limits or within the project limits but not specifically addressed in the Contract.
- 3.101. **Proposal.** The offer from the Bidder submitted on the prescribed form, including addenda issued, giving unit bid prices for performing the work described in the plans and Specifications.
- 3.102. **Proposal Form.** The form printed and sent to the Bidder by the Department or printed by the Bidder from the Department's bidding system.
- 3.103. **Proposal Guaranty.** The security furnished by the Bidder as a guarantee that the Bidder will enter into a Contract if awarded the work.
- 3.104. **Quality Assurance.** Sampling, testing, inspection, and other activities conducted by the Engineer to determine payment and make acceptance decisions.
- 3.105. **Quality Control.** Sampling, testing, and other process control activities conducted by the Contractor to monitor production and placement operations.
- 3.106. **Ramp.** A section of highway for the primary purpose of making connections with other highways.

- 3.107. **Recurring Maintenance Work Contracts.** Contracts or work for which maintenance is needed at the same location on more than one occasion (e.g., mowing contracts for which mowing cycles are requested on multiple occasions).
- 3.108. **Referee Tests.** Tests requested to resolve differences between Contractor and Engineer test results. The referee laboratory is the Construction Division.
- 3.109. **Regular Item.** A bid item contained in a proposal and not designated as an additive alternate or replacement alternate bid item.
- 3.110. **Rental Rate Blue Book for Construction Equipment.** Publication containing equipment rental rates.
- 3.111. **Replacement Alternate.** A bid item identified the proposal form that a Bidder may substitute for a specific regular item of work.
- 3.112. **Responsive Bid.** A proposal that meets all requirements of the proposal form for acceptance.
- 3.113. **Right of Way.** A general term denoting land or property devoted to transportation purposes.
- 3.114. **Roadbed.** The graded portion of a highway prepared as foundation for the pavement structure and shoulders. On divided highways, the depressed median type and the raised median type highways are considered to have 2 roadbeds. Highways with a flush median are considered to have 1 roadbed. Frontage roads are considered separate roadbeds.
- 3.115. **Road Master.** A railroad maintenance official in charge of a division of railway.
- 3.116. **Roadside.** The areas between the outside edges of the shoulders and the right of way boundaries. Unpaved median areas between inside shoulders of divided highways and areas within interchanges are included.
- 3.117. **Roadway.** The portion of the highway (including shoulders) used by the traveling public.
- 3.118. **Routine Maintenance Contract.** A Contract let through the routine maintenance contracting procedure to preserve and repair roadways, rights of way, and appurtenances.
- 3.119. **Sandblasting, Dry.** Spraying blasts of pressurized air combined with sand.
- 3.120. **Sandblasting, Wet.** Spraying blasts of pressurized water combined with sand.
- 3.121. **Shoulder.** That portion of the roadway contiguous with the traffic lanes for accommodation of stopped vehicles for emergency use or for lateral support of base and surface courses.
- 3.122. **Shot Blasting.** Spraying blasts of pressurized air combined with metal shot.
- 3.123. **Sidewalk.** Portion of the right of way constructed exclusively for pedestrian use.
- 3.124. **Slurry Blasting.** Spraying blasts of pressurized air combined with a mixture of water and abrasive media.
- 3.125. **Special Provisions.** Additions or revisions to these standard specifications or special specifications.
- 3.126. **Special Specifications.** Supplemental specifications applicable to the Contract not covered by these standard specifications.
- 3.127. **Specifications.** Directives or requirements issued or made pertaining to the method and manner of performing the work or to quantities and qualities of materials to be furnished under the Contract. References to DMSs, ASTM or AASHTO specifications, or Department bulletins and manuals, imply the latest standard

or tentative standard in effect on the date of the proposal. The Engineer will consider incorporation of subsequent changes to these documents in accordance with Item 4, "Scope of Work."

- 3.128. **Small Business Enterprise.** A firm (including affiliates) whose annual gross receipts do not exceed the U.S. Small Business Administration's size standards for 4 consecutive years.
- 3.129. **State.** The State of Texas.
- 3.130. **State Holiday.** A holiday authorized by the State Legislature excluding optional state holidays and not listed in Section 1.3.86., "National Holidays." A list of state holidays can be found on the Department's website.
- 3.131. **Station.** A unit of measurement consisting of 100 horizontal feet.
- 3.132. **Subcontract.** The agreement between the Contractor and subcontractor establishing the obligations of the parties for furnishing of materials and performance of the work prescribed in the Contract documents.
- 3.133. **Subcontractor.** A Subcontractor is defined as an individual, partnership, limited liability company, corporation, or any combination thereof that the Contractor sublets, or proposes to sublet, any portion of a Contract, excluding a material supplier, a hauling firm hauling only from a commercial source to the project, truck owner-operator, wholly-owned subsidiary, or specialty-type businesses such as security companies and rental companies.
- 3.134. **Subsidiary.** Materials, labor, or other elements that because of their nature or quantity have not been identified as a separate item and are included within the items on which they necessarily depend.
- 3.135. **Substructure.** The part of the structure below the bridge seats but not including, bearings, drilled shafts, or piling. Parapets, back walls, wing walls of the abutments, and drainage structures are considered parts of the substructure.
- 3.136. **Superintendent.** The representative of the Contractor who is available at all times and able to receive instructions from the Engineer or authorized Department representatives and to act for the Contractor.
- 3.137. **Superstructure.** The part of the structure above the bridge seats or above the springing lines of arches and including the bearings. Flatwork construction may be considered superstructure.
- 3.138. **Supplemental Agreement.** Written agreement entered into between the Contractor and the State and approved by the Surety, covering alterations and changes in the Contract. A supplemental agreement is used by the Department whenever the modifications include assignment of the Contract from one entity to another or other cases as desired by the Department.
- 3.139. **Surety.** The corporate body or bodies authorized to do business in Texas bound with and for the Contractor for the faithful performance of the work covered by the Contract and for the payment for all labor and material supplied in the prosecution of the work.
- 3.140. **Surplus Materials.** Any debris or material related to the Contract not incorporated into the work.
- 3.141. **Suspension.** Action taken by the Department or federal government pursuant to regulation that prohibits a person or company from entering into a Contract, or from participating as a subcontractor, or supplier of materials or equipment used in a highway improvement Contract as defined in Transportation Code, Chapter 223, Subchapter A.
- 3.142. **Traffic Lane.** The strip of roadway intended to accommodate the forward movement of a single line of vehicles.
- 3.143. **Traveled Way.** The portion of the roadway for the movement of vehicles, exclusive of shoulders and auxiliary lanes.

- 3.144. **Truck Owner-Operator.** An individual who owns and operates 1 truck for hire.
- 3.145. **UT-Bridge.** Department-owned software for steel girder erection. Software is available on the Department's website.
- 3.146. **UT-Lift.** Department-owned software for steel girder erection. Software is available on the Department's website.
- 3.147. **Utility.** Privately, publicly, or cooperatively owned lines, facilities, and systems for producing, transmitting, or distributing communications, power, heat, gas, oil, water, waste, or storm water that are not connected with the highway drainage, signal systems, or other products that directly or indirectly serve the public; the utility company.
- 3.148. **Verification Tests.** Tests used to verify accuracy of QC and QA and mixture design testing.
- 3.149. **Water-Abrasive Blasting.** Spraying blasts of pressurized water combined with abrasive media.
- 3.150. **Water Blasting.** Spraying blasts of pressurized water of at least 3,000 psi.
- 3.151. **Water-Injected Abrasive Blasting.** Abrasive blasting with water injected into the abrasive/air stream at the nozzle.
- 3.152. **Wholly-Owned Subsidiary.** A legal entity owned entirely by the Contractor or subcontractor.
- 3.153. **Work.** The furnishing of all labor, materials, equipment, and other incidentals necessary for the successful completion of the Contract.
- 3.154. **Work Order.** Written notice to the Contractor to begin the work. The work order may include the date when work and time charges will begin, the allowable number of working days, and plan sheets providing details specific to a location or to an item of work for non-site-specific work. A work order is part of the Contract.
- 3.155. **Written Notice.** Written notice is considered to have been duly given if delivered in person to the individual or member to whom it is intended or if sent by regular, registered, or certified mail and delivered to the last known business address; sent by facsimile to the last known phone number; or sent by e-mail to the last known address. The date of the letter will serve as the beginning day of notice. Unclaimed mail or failure to provide current contact information will not be considered a failure to provide written notice.

Item 2

Instructions to Bidders



1. INTRODUCTION

Instructions to the Contractor in these Specifications are generally written in active voice, imperative mood. The subject of imperative sentences is understood to be “the Contractor.” The Department’s responsibilities are generally written in passive voice, indicative mood. Phrases such as “as approved,” “unless otherwise approved,” “upon approval,” “as directed,” “as verified,” “as ordered,” and “as determined” refer to actions of the Engineer unless otherwise stated, and it is understood that the directions, orders, or instructions to which they relate are within the limitations of and authorized by the Contract.

2. ELIGIBILITY OF BIDDERS

Obtain a prequalification form from the Department’s website. A Bidder may choose to be prequalified by submitting either a Confidential Questionnaire or a Bidder’s Questionnaire. Submit the appropriate questionnaire at least 10 calendar days before the last day of the bid opening for the District or statewide letting. Comply with all technical prequalification requirements in the proposal.

2.1. **Confidential Questionnaire.** Submit a Confidential Questionnaire and an audited financial statement for approval. Once prequalified, a Bidder’s eligibility is valid for a period of one year from the balance sheet statement date.

2.2. **Bidder’s Questionnaire.** Bidders prequalified with a Bidder’s Questionnaire are only eligible to bid on projects identified as being waived from the requirements of Section 2.2.1., “Confidential Questionnaire.” These projects are designated with a “W” on the Proposal Request Form. Submit a Bidder’s Questionnaire for approval. Once prequalified, a Bidder’s eligibility is valid for a period of one year from the date the Bidder’s Questionnaire was received by the Department.

3. ISSUING PROPOSAL FORMS

The Department will issue a proposal form to a prequalified Bidder if the Engineer’s estimate is within that Bidder’s available bidding capacity. Request a proposal form electronically from the Department’s website. A proposal form printed directly from the Department’s website is for informational purposes only and will not be accepted as an official proposal form. In the case of a joint venture, all joint venture participants must be prequalified. An equally divided portion of the Engineer’s estimate must be within each participant’s available bidding capacity.

The Department will not issue a proposal form if one or more of the following apply:

- the Bidder is suspended or debarred by the Commission, Department, or any federal agency,
- the Bidder has not fulfilled the requirements for prequalification,
- the Bidder does not have the available bidding capacity,
- the Bidder is prohibited from rebidding a specific proposal form due to a bid error on the original proposal form,
- the Bidder failed to enter into a Contract on the original award,
- the Bidder was defaulted or terminated on the original Contract, unless the Department terminated in the best interest of the State or the public,
- the Bidder or a subsidiary or affiliate of the Bidder has received compensation from the Department to participate in the preparation of the plans or specifications on which the bid or Contract is based, or

- the Bidder is ineligible to bid on any proposed Contract in accordance with Article 7.15., “Responsibility for Damage Claims.”

4. INTERPRETING ESTIMATED QUANTITIES

The quantities listed in the proposal form are approximate and will be used for the comparison of bids. Payments will be made for the work performed in accordance with the Contract.

5. EXAMINING DOCUMENTS AND WORK LOCATIONS

Examine the proposal form, plans, specifications, and specified work locations before submitting a bid for the work. Submitting a bid will be considered evidence that the Bidder has performed this examination. Borings, soil profiles, water elevations, and underground utilities shown on the plans were obtained for use of the Department in the preparation of plans. This information is provided for the Bidder’s information only and the Department makes no representation as to the accuracy of the data. Be aware of the difficulty of accurately classifying all material encountered in making foundation investigations, the possible erosion of stream channels and banks after survey data have been obtained, and the unreliability of water elevations other than for the date recorded.

Oral explanations, instructions, or consideration for Contractor-proposed changes in the proposal form given during the bidding process are not binding. Only requirements included in the proposal form, associated specifications, plans, and Department-issued addenda are binding. Request explanations of documents in adequate time to allow the Department to reply before the bid opening.

Immediately notify the Department of any error, omission, or ambiguity discovered in any part of the proposal form and Contract documents. The Department will issue addenda when appropriate.

6. PREPARING THE BID

Prepare the bid on the proposal form furnished by the Department. Informational proposal forms printed from the Department’s website will not be accepted.

Specify a unit price in dollars and cents for each regular item and additive alternate item, or replacement alternate item for which an estimated quantity is given.

When “Working Days” is an Item, submit the number of working days to be used to complete the Contract or phases of the Contract shown on the plans.

The Department will not accept an incomplete bid. A bid that has one or more of the deficiencies listed below is considered incomplete:

- the proposal form was not signed,
- certifications were not acknowledged,
- a regular item or the additive alternate item are left blank,
- a regular item and the corresponding replacement alternate item are left blank,
- the proposal form submitted had the incorrect number of items, or
- the Bidder did not acknowledge all addenda.

7. NONRESPONSIVE BID

The Department will not accept a nonresponsive bid. A bid that has one or more of the deficiencies listed below is considered nonresponsive:

- the bid was not in the hands of the Letting Official at the time and location specified in the advertisement,

- a bid was submitted for the same proposal form by a Bidder or Bidders and one or more of its partners or affiliates,
- the Bidder was not authorized to receive a proposal form under Article 2.3., "Issuing Proposal Forms",
- the Bidder failed to acknowledge receipt of all addenda issued,
- the proposal form was signed by a person who was not authorized to bind the Bidder or Bidders.
- the proposal guaranty did not comply with the requirements contained in this Item,
- the bid was in a form other than the official proposal form issued by the Department,
- the Bidder modified the bid in a manner that altered the conditions or requirements for work as stated in the proposal form,
- the Bidder bid more than the maximum or less than the minimum number of allowable working days shown on the plans when working days was an Item,
- the Bidder did not attend a specified mandatory pre-bid conference, or
- the Bidder did not meet the requirements of the technical qualification.

8. ELECTRONIC BID

The Bidder is responsible for taking the appropriate measures to submit a bid. These measures include, but are not limited to acquiring hardware, software, and Internet connectivity needed for submitting a bid via the Department's bidding system.

- 8.1. **Proposal Form.** Use the electronic proposal form in the Department's bidding system. When regular bid items have corresponding replacement alternate items, select the bid item or group of items to be used for the bid tabulation. Acknowledge all addenda listed in the Department's bidding system.

The electronic proposal form does not contain the special provisions, special specifications, general notes, and other Contract documents. These documents are included by reference.

- 8.2. **Proposal Guaranty.** Provide a proposal guaranty in the amount indicated on the proposal form. Use an electronic bid bond. Guaranty checks or printed bid bonds will not be accepted.

Use the most current version of the electronic bond issued by the Department. For a joint venture, the bond must be in the name of all joint venture participants. Enter the bond authorization code into the Department's bidding system.

It is the Bidder's responsibility to ensure the electronic bid bond is issued in the name or names of the Bidder or Bidders.

- 8.3. **Submittal of Bid.** Submit the bid to the vault using the Department's bidding system.

- 8.4. **Revising the Proposal Form.** Make desired changes in the Department's bidding system up until the time and date set for the opening of bids. The last bid submitted to the vault will be used for tabulation purposes.

- 8.5. **Withdrawing a Bid.** Submit an electronic or written request to withdraw a bid before the time and date set for the opening. The Department will not accept oral requests. An electronic request must be made using the Department's bidding system.

A written request must be signed and submitted to the Letting Official with proof of identification. The request must be made by a person authorized to bind the Bidder or Bidders. In the case of joint venture, the Department will accept a request from any person authorized to bind a party to the joint venture. The Department may require written delegation of authority to withdraw a bid when the individual sent to withdraw the bid is not authorized to bind the Bidder or Bidders.

9. PRINTED BID

- 9.1. **Proposal Form.** Mark all entries in ink. As an alternative to hand writing the unit prices in the proposal form, submit a typed proposal form. A typed proposal form must contain the information in the format shown on the “Example of Bid Prices Submitted by Computer Printout” in the proposal form.

When regular bid items have corresponding replacement alternate items, select the bid item or group of items to be used for the bid tabulation. Acknowledge all addenda by checking the appropriate box on the addendum acknowledgement page. Provide the complete and correct name of the Bidder submitting the bid. A person authorized to bind the Bidder must sign the proposal form. In the case of a joint venture, provide the complete and correct name of all Bidders submitting the bid. In the case of a joint venture, the person signing the proposal form must be authorized to bind all joint venture participants.

If a proposal form contains both regular items for domestic steel or iron materials and replacement alternate items for foreign steel or iron materials, the Bidder must either:

- submit unit bid prices for domestic items only, or
- submit unit bid prices for both the domestic and foreign items.

- 9.2. **Proposal Guaranty.** Provide a proposal guaranty in the amount indicated on the proposal form. Use either a guaranty check or a printed bid bond. An electronic bid bond may be used as the guaranty. Ensure the electronic bid bond meets the requirements of Section 2.8.2., “Proposal Guaranty,” and submit the electronic bid bond with the printed bid.

- 9.2.1. **Guaranty Check.** Make the check payable to the Texas Transportation Commission or the Texas Department of Transportation. The check must be a cashier’s check, money order, or teller’s check drawn by or on a state or national bank, or a state or federally chartered credit union (collectively referred to as “bank”). The check must be dated on or before the date of the bid opening. Postdated checks will not be accepted. The type of check or money order must be indicated on the face of the instrument, except in the case of a teller’s check, and the instrument must be no more than 90 days old. A check must be made payable at or through the institution issuing the instrument; be drawn by a bank and on a bank; or be payable at or through a bank. The Department will not accept personal checks, certified checks, or other types of money orders.

- 9.2.2. **Bid Bond.** Use the bid bond form provided by the Department. Submit the bid bond in the amount specified with the powers of attorney dated and attached. The bond must be dated on or before the date of the bid opening, bear the impressed seal of the Surety, and be signed by the Bidder or Bidders and an authorized individual of the Surety. As an alternative for joint venture Bidders, each of the Bidders may submit a separate bid bond completed as outlined in this Section. Bid bonds will only be accepted from Sureties authorized to execute a bond under and in accordance with state law.

- 9.3. **Submittal of Bid.** Place the completed proposal form and the proposal guaranty in a sealed envelope marked to indicate the contents.

When submitting by mail or delivery service, place the envelope in another sealed envelope and address as indicated in the official advertisement. It is the Bidder’s responsibility to ensure that the sealed bid arrives at the location described on or before the time and date set for the bid opening. To be accepted, the bid must be in the hands of the Letting Official by that time of opening regardless of the method chosen for delivery.

- 9.4. **Revising the Proposal Form.** Make desired changes to the proposal form in ink, initial each change made, and submit the proposal to the Letting Official. Correction fluid or tape will be considered a change to the bid and requires the initials of the Bidder. The Department will not make revisions to a bid on behalf of a Bidder.

- 9.5. **Withdrawing a Bid.** Submit a written request to withdraw a bid before the time and date set for the opening. The Department will not accept oral requests. A written request must be signed and submitted to the Letting Official with proof of identification. The request must be made by a person authorized to bind the Bidder or Bidders. In the case of joint venture, the Department will accept a request from any person authorized to bind

a party to the joint venture. The Department may require written delegation of authority to withdraw a bid when the individual sent to withdraw the bid is not authorized to bind the Bidder or Bidders.

10. OPENING AND READING OF BIDS

At the time, date, and location specified in the official advertisement, the Letting Official will publicly open and read bids.

11. TABULATING BIDS

11.1. **Official Total Bid Amount.** The Department will sum the products of the quantities and the unit prices bid in the proposal form to determine the official total bid amount, except as provided in Section 2.11.5., "Consideration of Unit Prices." The official total bid amount is the basis for determining the apparent low Bidder. The total bid amounts will be compared and the results made public.

11.2. **Consideration of Bid Format.** When a Bidder submits both an electronic bid and a printed bid that is responsive, the unit bid prices in the printed bid will be used to determine the total bid amount. If the printed bid is incomplete or nonresponsive, the electronic bid will be used in the tabulation of the total bid amount.

If a Bidder submits 2 or more printed bids, all responsive bids will be tabulated. The bid with the lowest tabulation will be used to determine the total bid amount.

11.3. **Rounding of Unit Prices.** The Department will round off all unit bids involving fractional parts of a cent to the nearest one-tenth cent (\$0.001) in determining the amount of the bid as well as computing the amount due for payment of each item under the Contract. For rounding purposes, entries of five-hundredths of a cent (\$0.0005) or more will be rounded up to the next highest tenth of a cent, while entries less than five-hundredths of a cent will be rounded down to the next lowest tenth of a cent.

11.4. **Interpretation of Unit Prices.** The Department will make a documented determination of the unit bid price if a unit bid price is illegible or conflicting in the case of replacement alternate items. The Department's determination will be final.

11.5. **Consideration of Unit Prices.**

11.5.1. **Additive Alternate Items.** The Department will sum the products of the quantities and the unit prices bid for the regular items in the proposal form to determine the total bid amount for the base bid. The official total bid amount will be determined by the summation of the base bid plus a pre-determined order of additive alternate items, not to exceed the Department's budgeted amount for the Contract. An estimate of the budgeted amount may be shown on the plans.

The Contract will identify the base bid work and additive alternate work to be performed. The Department makes no guarantee that the additive alternate work will be required.

11.5.2. **A + B Bidding.** The official total bid amount will be determined by the summation of the Contract amount and the time element. The Department will use the following formula to make the calculation:

$$A + B1 + B2 + BX + \dots + BT$$

The Contract amount, equal to A in the formula, is determined by the summation of the products of the approximate quantities shown in the proposal and the unit bid prices bid, and the time element, equal to B1, B2, BX (when phases are included as bid components), and BT (substantial completion of the project when included as a bid component), of the bid is determined by multiplying the number of working days bid to substantially complete the project, or phases, by the daily road-user cost (RUC) provided on the plans. When partial days are bid they will be rounded up to the nearest whole day.

The formula above determines the low Bidder and establishes the Contract time.

11.5.3. **Rubber Additives.** For proposed Contracts without federal funds, if an alternate item for “Hot Asphalt-Rubber Surface Treatments” or “Hot-Mix Asphalt Concrete Pavement” which contains ground tire rubber is shown in the proposal form and the Bidder bids that alternate item, the amounts bid for “Hot Asphalt-Rubber” and “Aggregate” or “Hot-Mix Asphalt Concrete” will be reduced to 85% of the amounts actually bid. This reduction will only be used for the purposes of determining the lowest Bidder. To qualify, the ground tire rubber used must be produced from scrap tire ground in a facility in Texas. Payment for “Hot Asphalt-Rubber” and “Aggregate” or “Hot-Mix Asphalt Concrete” will be at the actual unit prices bid.

11.5.4. **“Buy America.”** The use of foreign steel is only allowed when shown on the plans. For a Bidder who proposes to use foreign steel or iron materials to be considered the apparent low Bidder, their total bid must be at least 25% lower than the next lowest bid if that bid proposes to use domestic steel or iron materials.

This requirement does not apply to minimal use of steel or iron materials provided that the total cost of all foreign source items used in the project, as delivered to the project site, is less than \$2,500 or one-tenth-of-one-percent (1/10 of 1%) of the Contract amount, whichever is greater.

11.5.5. **Home State Bidding Preference.** For the purpose of determining the apparent low Bidder on proposed Contracts without federal funds, the Department will select the option that results in the greatest bidding preference to the resident Bidder.

11.5.5.1. **Reverse Application of Non-Resident Bidder’s Home State Bidding Preference.** The total bid amount will be based upon the reverse application of the non-resident Bidder’s home state bidding preference, if any. This will also apply to another state’s preference for a Bidder that offers materials grown, produced, processed, or manufactured in that state.

Any reverse application of the home state bidding preference would be the greater of the following:

- the amount by which a resident Bidder would be required to underbid the non-resident Bidder to obtain a comparable contract in the state in which the non-resident’s principle place of business is located; or
- the amount by which a resident Bidder would be required to underbid the non-resident Bidder to obtain a comparable contract in the state in which a majority of the manufacturing relating to the Contract will be performed.

11.5.5.2. **Texas Home State Bidding Preference.** A Bidder will be considered the apparent low Bidder if the Bidder’s home office is located in this state and their bid does not exceed an amount equal to 105% of the apparent low bid received from a Bidder whose home office is not located in this state. This will not apply to a Bidder from a bordering state whose state does not give a preference to a Bidder in a manner similar to this Section.

12. CONSIDERATION OF BID ERRORS

The Department will consider a claim of a bid error by the apparent low Bidder if the following requirements have been met:

- a written notification is submitted to the Department within 5 business days after the date the bid is opened; and
- the submittal identifies the items of work involved and include bidding documentation. The Department may request clarification of submitted documentation.

The Department will evaluate the claim of an error by the apparent low Bidder by considering the following:

- the bid error relates to a material item of work,
- the bid error amount is a significant portion of the total bid,
- the bid error occurred despite the exercise of ordinary care, and
- the delay of the proposed work will not impact cost and safety to the public.

Acceptance of the bid error claim by the Department will result in the rejection of all bids. The erring Contractor will not be allowed to bid the project when it is relet. Rejection of bids due to the Contractor's bid error may result in the application of sanctions by the Department.

13. TIE BIDS

If the official total bid amount for 2 or more Bidders is equal and those bids are the lowest submitted, each tie Bidder will be given an opportunity to withdraw their bid. If 2 or more tie Bidders do not withdraw their bids, the low Bidder will be determined by a coin toss or a series of coin tosses when there are more than 2 Bidders. If all tie Bidders request to withdraw their bids, no withdrawals will be allowed and the low Bidder will be determined by a coin toss or a series of coin tosses when there are more than 2 Bidders. The Letting Official will preside over the proceedings.

Item 3

Award and Execution of Contract



1. AWARD OF CONTRACT

The Commission or designated representative will award, reject, or defer the Contract within 30 days after the opening of the proposal. The Department reserves the right to reject any or all proposals and to waive technicalities in the best interest of the State.

1.1. **Award.** The Commission or designated representative will award the Contract to the low Bidder as determined by Article 2.11., "Tabulating Bids." The Commission may award a Contract to the second lowest Bidder when the following requirements have been met:

- the Contract is for maintenance work with an Engineer's estimate less than \$300,000 and the Contract does not include federal funds,
- the low Bidder withdraws its bid or fails to enter into Contract,
- the second lowest Bidder agrees to perform the work at the unit bid prices of the low Bidder,
- the Executive Director recommends in writing the award of the Contract to the second lowest Bidder, and
- the Commission agrees with the Executive Director's recommendation for award to the second lowest Bidder.

1.2. **Rejection.** The Commission or designated representative will reject the Contract if:

- collusion may have existed among the Bidders. Collusion participants will not be allowed to bid future proposals for the same Contract,
- the low bid is mathematically and materially unbalanced. The Bidder will not be allowed to bid future proposals for the same Contract,
- the lowest bid is higher than the Department's estimate and re-advertising for bids may result in a lower bid,
- the low bid contains a bid error that satisfies the requirements and criteria in Article 2.12., "Consideration of Bid Errors," or
- rejection of the Contract is in the best interest of the State.

1.3. **Deferral.** The Commission may defer the award or rejection of the Contract when deferral is in the best interest of the State.

2. RESCINDING OF AWARD

The Commission or designated representative reserves the right to cancel the award of any Contract before contract execution with no compensation due when the cancellation is in the best interest of the State. The Department will return the proposal guaranty to the Contractor.

3. DISADVANTAGED BUSINESS ENTERPRISE (DBE)/SMALL BUSINESS ENTERPRISE (SBE)

Submit all DBE/SBE information in the timeframe specified when required by the proposal.

4. EXECUTION OF CONTRACT

Provide the following within 15 days after written notification of award of the Contract.

4.1. **Contract.** Execute the Contract as prescribed by the Department.

4.2. **Bonds.** Execute and date the performance and payment bond in the full amount of the Contract with the powers of attorney. Provide bonds in accordance with Table 1. Furnish the payment and performance bonds as a guaranty for the protection of the claimants and the Department for labor and materials and the faithful performance of the work.

**Table 1
Bonding Requirements**

Contract Amount	Required Bonds
Less than \$25,000	None
\$25,000 to \$100,000	Payment
More than \$100,000	Performance and Payment

Sample versions of the standard performance and payment bonds may be viewed on the Department’s website.

4.3. **Insurance.** Submit a certificate of insurance showing coverages in accordance with Contract requirements.

Insurances must cover the work for the duration of the Contract and must remain in effect until final acceptance. Failure to obtain and maintain insurance for the contracted work may result in suspension of work or default of the Contract. If the insurance expires and coverage lapses for any reason, stop all work until the Department receives an acceptable certificate of insurance.

Provide the Department with a certificate of insurance verifying the types and amounts of coverage shown in Table 2. The certificate of insurance must be in a form approved by the Texas Department of Insurance. Any certificate of insurance provided must be available for public inspection.

**Table 2
Insurance Requirements**

Type of Insurance	Amount of Coverage
Commercial General Liability Insurance	Not Less Than: \$1,000,000 each occurrence
Business Automobile Policy	Not Less Than: \$600,000 combined single limit
Workers’ Compensation	Not Less Than: Statutory
All Risk Builder’s Risk Insurance (For building-facilities contracts only)	100% of Contract Price

By signing the Contract, the Contractor certifies compliance with all applicable laws, rules, and regulations pertaining to workers’ compensation insurance. This certification includes all subcontractors. Pay all deductibles stated in the policy. Subcontractors must meet the requirements of Table 2 either through their own coverage or through the Contractor’s coverage.

The Workers’ Compensation policy must include a waiver of subrogation endorsement in favor of the Department.

For building-facilities contracts, provide All Risk Builder’s Risk Insurance to protect the Department against loss by storm, fire or extended coverage perils on work and materials intended for use on the project including the adjacent structure. Name the Department under the Lost Payable Clause.

For contracts with railroad requirements, see project-specific details for additional insurance requirements.

Provide a substitute Surety on the Contract bonds in the original full Contract amount within 15 days of notification if the Surety is declared bankrupt or insolvent, the Surety’s underwriting limitation drops below the Contract amount or the Surety’s right to do business is terminated by the State. The substitute Surety must be authorized by the laws of the State and acceptable to the Department. Work will be suspended until a substitute Surety is provided. Working day charges will be suspended for 15 days or until an acceptable Surety is provided, whichever is sooner.

The work performed under this section will not be measured or paid for directly but will be subsidiary to pertinent Items.

- 4.4. **Business Ownership Information.** Submit the names and social security numbers of all individuals owning 25% or more of the firm, or firms in the case of a joint venture, on the Department’s form.
- 4.5. **List of Quoting Suppliers and Subcontractors.** For a construction Contracts, submit a list of all suppliers and subcontractors that quoted on the Contract. Include names, addresses, telephone numbers, and types of work required.
- 4.6. **Railroad Documents.** Provide all required documents for satisfaction of railroad requirements for projects that have work which involves railroad right of way. Comply with the requirements of Article 5.8., “Cooperation With Railroads.”

5. FAILURE TO ENTER CONTRACT

If the Contractor fails to comply with all of the requirements in Article 3.4., “Execution of Contract,” the proposal guaranty will become the property of the State, not as a penalty, but as liquidated damages. The Contractor forfeiting the proposal guaranty will not be considered in future proposals for the same work unless there has been a substantial change in design of the work.

6. APPROVAL AND EXECUTION OF CONTRACT

The Contract will be approved and signed under authority of the Commission.

7. RETURN OF PROPOSAL GUARANTY

The proposal guaranty check of the low Bidder will be retained until after the Contract has been rejected or awarded and executed. Bid bonds will not be returned.

8. BEGINNING OF WORK

Do not begin work until authorized in writing by the Engineer.

Verify all quantities of materials shown on the plans before ordering.

For Contracts with callout work and work orders, the purchase of materials before a work order is issued or without prior written approval of the Engineer is at the Contractor’s risk, and the Department is not obligated for the cost of the materials or work to acquire the materials.

9. ASSIGNMENT OF CONTRACT

Do not assign, sell, transfer, or otherwise dispose of the Contract or any portion rights, title, or interest (including claims) without the approval of the Commission or designated representative. The Department must deem any proposed assignment justified and legally acceptable before the assignment can take place.

10.**EXCLUDED PARTIES**

The Contractor certifies by signing the Contract that the Contractor will not enter into any subcontract with a subcontractor that is debarred or suspended by the Department or any federal agency.

Item 4

Scope of Work



1. CONTRACT INTENT

The intent of the Contract is to describe the completed work to be performed. Furnish materials, supplies, tools, equipment, labor, and other incidentals necessary for the proper prosecution and completion of the work in accordance with Contract documents.

2. PRECONSTRUCTION CONFERENCE

Before starting work, schedule and attend a preconstruction conference with the Engineer. Failure to schedule and attend a preconstruction conference is not grounds for delaying the beginning of working day charges. The preconstruction conference may be scheduled with the safety preconstruction meeting described in Section 7.2.2., "Safety Preconstruction Meeting" and the railroad coordination meeting described in Article 5.8, "Cooperation With Railroads". Work with the Engineer to resolve or escalate all issues. Execute the project pledge and establish an issue escalation ladder.

2.1. **Project Pledge.** Contractor representatives at the level of foreman and above will certify in writing they will approach the construction of this project in a manner consistent with delivering a high quality project in a safe, cost-effective, and timely manner, and they will be committed to not allowing personality conflicts or personal interests to interfere with providing the public with a quality project. Failure to uphold this commitment may result in grounds for removal from the project.

2.2. **Issue Resolution Process.** An issue is any aspect of the Contract where parties of the Contract do not agree. The individuals identified at the lowest level of the issue escalation ladder will initiate the issue resolution process by escalating any issue that remains unresolved within the time frame outlined in the issue escalation ladder.

Work with the Engineer to resolve all issues during the course of the Contract. Refer to Article 4.7., "Dispute or Claims Procedure" for all unresolved issues.

3. PARTNERING

The intent of this section is to promote an environment of trust, mutual respect, integrity, and fair-dealing between the Department and the Contractor.

Informal partnering does not make use of a facilitator, while formal partnering uses the services of a facilitator (internal or external).

3.1. **Procedures for Partnering Meetings and Format.** Informal partnering is required, unless formal partnering is mutually agreed to in lieu of the informal partnering.

3.2. **Facilitators.** The facilitator is to act as a neutral party seeking to initiate cooperative working relationships. This individual must have the technical knowledge and ability to lead and guide discussions. Choose either an internal or external facilitator. The facilitator must be acceptable to the Engineer.

3.2.1. **Internal Facilitators.** A Department or Contractor staff member may be selected as the facilitator at no additional cost to either party.

- 3.2.2. **External Facilitators.** A private firm or individual that is independent of the Contractor and the Department may be selected as the facilitator. Submit the facilitator's name and estimated fees for approval before contracting with the facilitator.
- 3.3. **Meetings and Arrangements.** Coordinate with the Engineer for meeting dates and times, locations including third party facilities, and other needs and appurtenances including but not limited to audio or visual equipment. Make all meeting arrangements for formal partnering. Use Department facilities or facilities in the vicinity of the project if available. Submit the estimated meeting costs for approval before finalizing arrangements.
- Coordinate facilitator discussions before the partnering meeting to allow the facilitator time to prepare an appropriate agenda. Prepare a list of attendees with job titles and include critical Contractor, subcontractor, and supplier staff in the list. Provide the facilitator the list of attendees and invite the attendees listed.
- The Department will invite and provide a list of attendees that includes but is not limited to Department, City, County, law enforcement, railroad, and utility representatives.
- Participate in additional partnering meetings as mutually agreed.
- 3.4. **Payment.** Expenses for labor, Contractor equipment, or overhead will not be allowed. Markups as prescribed in Article 9.7., "Payment for Extra Work and Force Account Method," will not be allowed.
- Informal partnering will be conducted with each party responsible for their own costs.
- For formal partnering using internal facilitators, the Contractor will be responsible for arrangements and for expenses incurred by its internal facilitator, including but not limited to meals, travel, and lodging. Department facilitators may be used at no additional cost.
- For formal partnering using external facilitators, submit an invoice to the Engineer for reimbursement. The Department will reimburse the Contractor for half of the eligible expenses as approved. For external facilitators not approved by the Department but used at the Contractor's option, the Contractor will be responsible for all costs of the external facilitator.
- For meeting facilities and appurtenances, submit an invoice to the Engineer for reimbursement. The Department will reimburse the Contractor for half of the eligible expenses as approved.

4. **CHANGES IN THE WORK**

The Engineer reserves the right to make changes in the work including addition, reduction, or elimination of quantities and alterations needed to complete the Contract. Perform the work as altered. These changes will not invalidate the Contract nor release the Surety. The Contractor is responsible for notifying the sureties of any changes to the Contract.

If the changes in quantities or the alterations do not significantly change the character of the work under the Contract, the altered work will be paid for at the Contract unit price. If the changes in quantities or the alterations significantly change the character of the work, the Contract will be amended by a change order. If no unit prices exist, this will be considered extra work and the Contract will be amended by a change order. Provide cost justification as requested, in an acceptable format. Payment will not be made for anticipated profits on work that is eliminated.

Agree on the scope of work and the basis of payment for the change order before beginning the work. If there is no agreement, the Engineer may order the work to proceed under Article 9.7., "Payment for Extra Work and Force Account Method," or by making an interim adjustment to the Contract. In the case of an adjustment, the Engineer will consider modifying the compensation after the work is performed.

A significant change in the character of the work occurs when:

- the character of the work for any item as altered differs materially in kind or nature from that in the Contract, or
- a major item of work varies by more than 25% from the original Contract quantity, except for non-site-specific Contracts.

When the quantity of work to be done under any major item of the Contract is more than 125% of the original quantity stated in the Contract, then either party to the Contract may request an adjustment to the unit price on the portion of the work that is above 125%.

When the quantity of work to be done under any major item of the Contract is less than 75% of the original quantity stated in the Contract, then either party to the Contract may request an adjustment to the unit price. Adjust the unit price by multiplying the Contract unit price by the factor in Table 1.

Table 1
Quantity-Based Price Adjustment Factors

% of Original Quantity	Factor
≥ 50 and < 75	1.05
≥ 25 and < 50	1.15
< 25	1.25

If the changes require additional working days to complete the Contract, Contract working days will be adjusted in accordance with Item 8, "Prosecution and Progress."

5. DIFFERING SITE CONDITIONS

During the progress of the work, differing subsurface or latent physical conditions may be encountered at the site. The 2 types of differing site conditions are defined as:

- those that differ materially from those indicated in the Contract, and
- unknown physical conditions of an unusual nature differing materially from those ordinarily encountered and generally recognized as inherent in the work provided for in the Contract.

Notify the Engineer in writing when differing site conditions are encountered. The Engineer will notify the Contractor when the Department discovers differing site conditions. Unless directed otherwise, suspend work on the affected items and leave the site undisturbed. The Engineer will investigate the conditions and determine whether differing site conditions exist. If the differing site conditions cause an increase or decrease in the cost or number of working days specified for the performance of the Contract, the Engineer will make adjustments, excluding the loss of anticipated profits, in accordance with the Contract. Additional compensation will be made only if the required written notice has been provided.

6. REQUESTS FOR ADDITIONAL COMPENSATION AND DAMAGES

Notify the Engineer in writing of any intent to request additional compensation once there is knowledge of the basis for the request. An assessment of damages is not required to be part of this notice but is desirable. The intent of the written notice requirement is to provide the Engineer an opportunity to evaluate the request and to keep an accurate account of the actual costs that may arise. Minimize impacts and costs.

If written notice is not given, the Contractor waives the right to additional compensation unless the circumstances could have reasonably prevented the Contractor from knowing the cost impact before performing the work. Notice of the request and the documentation of the costs will not be construed as proof or substantiation of the validity of the request. Submit the request in enough detail to enable the Engineer to determine the basis for entitlement, adjustment in the number of working days specified in the Contract, and compensation.

Damages occur when impacts that are the responsibility of the Department result in additional costs to the Contractor that could not have been reasonably anticipated at the time of letting. Costs of performing

additional work are not considered damages. For Contractor damages, the intent is to reimburse the Contractor for actual expenses arising out of a compensable impact. No profit or markups, other than labor burden, will be allowed. For damages, labor burden will be reimbursed at 35% unless the Contractor can justify higher actual cost. Justification for a higher percentage must be in accordance with the methodology provided by the Department, submitted separately for project overhead labor and direct labor, and determined and submitted by a Certified Public Accountant (CPA). Submit CPA-prepared labor burden rates directly to the Construction Division for approval.

The Department will not consider fees and interest on requests for additional compensation and damages. Fees include, but are not limited to: preparation, attorney, printing, shipping, and various other fees.

If the Contractor requests compensation for damages and the damages are determined to be compensable, then standby equipment costs and project overhead compensation will be based on the duration of the compensable damage and will be limited as follows:

- 6.1. **Standby Equipment Costs.** Payment will be made in accordance with Section 9.7.1.4.3., "Standby Equipment Costs."
- 6.2. **Project Overhead.** Project overhead is defined as the administrative and supervisory expenses incurred at the work locations. When delay to project completion occurs, reimbursement for project overhead for the Contractor will be made using the following options:
- reimbursed at 6% (computed as daily cost by dividing 6% of the original Contract amount by the number of original Contract work days), or
 - actual documented costs for the impacted period.

Project overhead for delays impacting subcontractors will be determined from actual documented costs submitted by the Contractor.

Time extensions and suspensions alone will not be justification for reimbursement for project overhead.

- 6.3. **Home Office Overhead.** The Department will not compensate the Contractor for home office overhead.

7. DISPUTE OR CLAIMS PROCEDURE

The dispute resolution policy promotes a cooperative attitude between the Engineer and Contractor. Emphasis is placed on resolving issues while they are still current, at the area office or the district office, and in an informal manner. Open sharing of information is encouraged by all parties involved so the information provided completely and accurately reflects the issues and facts. If information is not shared, decisions may be limited to relying on the documentation that is available for review.

It is the Department's goal to have a dispute settled in the District before elevating it to the Contract Claim Committee (CCC) as a claim. The Construction Division can assist in the resolution of a dispute with a Contractor when requested by the District. The Contractor may request that a District ask for assistance of the Construction Division; however, the request for a recommendation prepared by the Construction Division to settle a dispute must come from the District.

If a dispute cannot be resolved, initiate the Contract claim procedure by submitting a claim to the District Engineer, the Director of the Construction Division, or the CCC.

The Department's Contract claim procedure has been established in accordance with Title 43 of the Texas Administrative Code, Part 1, Chapter 9, Subchapter A, Rule §9.2, *Contract Claim Procedure*. Detailed instructions for submitting a claim and its components can be found on the Department's website.

If a claim has been submitted and the Contractor wishes to resume negotiations with the District, notify the CCC in writing of the intent to resume negotiations at the District level and request review of the claim be suspended by the CCC pending the outcome of the negotiations.

File a claim after completion of the Contract or when required for orderly performance of the Contract. For a claim resulting from enforcement of a warranty period, file the claim no later than one year after expiration of the warranty period. For all other claims, file the claim no later than the date the Department issues notice to the Contractor that they are in default, the date the Department terminates the Contract, or one year after the date of final acceptance of the Contract. It is the Contractor's responsibility to submit requests in a timely manner.

Item 5

Control of the Work



1. AUTHORITY OF ENGINEER

The Engineer has the authority to observe, test, inspect, approve, and accept the work. The Engineer decides all questions about the quality and acceptability of materials, work performed, work progress, Contract interpretations, and acceptable Contract fulfillment. The Engineer has the authority to enforce and make effective these decisions.

The Engineer acts as a referee in all questions arising under the terms of the Contract. The Engineer's decisions will be final and binding.

The Engineer may pursue actions against the Contractor, including but not limited to the withholding of estimates and suspending the work, for noncompliance of the Contract.

The Engineer may suspend the work without suspending working day charges for noncompliance of the Contract.

2. PLANS AND WORKING DRAWINGS

When required, provide working drawings to supplement the plans with all necessary details not included on the Contract plans. Prepare and furnish working drawings in a timely manner and obtain approval, if required, before the beginning of the associated work. For all working drawing submittal requirements, the Engineer may allow electronic and other alternative submission procedures. Have a licensed professional engineer sign, seal, and date the working drawings as indicated in Table 1.

Prepare working drawings using United States standard measures in the English language. The routing of submittals for review and approval will be established at the preconstruction conference. The Contractor is responsible for the accuracy, coordination, and conformity of the various components and details of the working drawings. Department approval of the Contractor's working drawings will not relieve the Contractor of any responsibility under the Contract. The work performed under this Article will not be measured or paid for directly but will be subsidiary to pertinent Items.

**Table 1
Signature and Approval Requirements for Working Drawings**

Working Drawings For		Requires Licensed Professional Engineer's Signature, Seal, and Date	Requires Departmental Approval
1. Alternate or optional designs submitted by Contractor		Yes	Yes
2. Supplementary shop and fabrication drawings for structural Items		No unless required on the plans	See applicable Item
3. Contractor-proposed temporary facilities that affect the public safety, not included on the plans		Yes	Yes
4. Form and falsework details	Bridges, retaining walls, and other major structures	Yes unless otherwise shown on the plans	No ¹
	Minor structures	No unless otherwise shown on the plans	No
5. Erection drawings		Yes	No ^{1,2}
6. Contractor-proposed major modifications to traffic control plan		Yes	Yes

1. The Engineer may require that the Contractor have a licensed professional engineer certify that the temporary works are constructed according to the sealed drawings.
2. Approval is required for items spanning over live traffic or where safety of the traveling public is affected, in the opinion of the Engineer.

Submit shop drawings electronically for the fabrication of structural items as documented in the *Guide to Electronic Shop Drawing Submittal* available on the internet at ftp://ftp.dot.state.tx.us/pub/txdot-info/library/pubs/bus/bridge/e_submit_guide.pdf and as directed for other items required by the Contract. References to 11 × 17-in. sheets in individual specifications for structural items imply electronic computer aided design sheets.

3. CONFORMITY WITH PLANS, SPECIFICATIONS, AND SPECIAL PROVISIONS

Furnish materials and perform work in reasonably close conformity with the lines, grades, cross-sections, dimensions, details, gradations, physical and chemical characteristics of materials, and other requirements shown in the Contract. Reasonably close conformity limits will be as defined in the respective Items of the Contract or, if not defined, as determined by the Engineer. Obtain approval before deviating from the plans and approved working drawings. Do not perform work beyond the lines and grades shown on the plans or any extra work without the Engineer's authority. Work performed beyond the lines and grades shown on the plans or any extra work performed without authority is considered unauthorized and excluded from pay consideration. The Department will not pay for material rejected due to improper fabrication, excess quantity, or any other reasons within the Contractor's control.

- 3.1. **Acceptance of Defective or Unauthorized Work.** When work fails to meet Contract requirements, but is adequate to serve the design purpose, the Engineer will decide the extent to which the work will be accepted and remain in place. The Engineer will document the basis of acceptance by a letter and may adjust the Contract price.
- 3.2. **Correction of Defective or Unauthorized Work.** When work fails to meet Contract requirements and is inadequate to serve the design purpose it will be considered defective. Correct, or remove and replace, the work at the Contractor's expense, as directed.

The Department has the authority to correct or to remove and replace defective or unauthorized work. The cost may be deducted from any money due or to become due to the Contractor.

4. COORDINATION OF PLANS, SPECIFICATIONS, AND SPECIAL PROVISIONS

The specifications, accompanying plans, special provisions, change orders, and supplemental agreements are intended to work together and be interpreted as a whole.

Numerical dimensions govern over scaled dimensions. Special provisions govern over plans (including general notes), which govern over standard specifications and special specifications. Job-specific plan sheets govern over standard plan sheets.

However, in the case of conflict between plans (including general notes) and specifications regarding responsibilities for hazardous materials and traffic control in Items 1 through 9, "General Requirements and Conditions and Item 502, "Barricades, Signs, and Traffic Handling," special provisions govern over standard specifications and special specifications, which govern over the plans.

Notify the Engineer promptly of any omissions, errors, or discrepancies discovered so that necessary corrections and interpretations can be made. Failure to promptly notify the Engineer will constitute a waiver of all claims for misunderstandings or ambiguities that result from the errors, omissions, or discrepancies discovered.

5. COOPERATION OF CONTRACTOR

Cooperate with the Engineer. Respond promptly to instructions from the Engineer. Provide all information necessary for the successful completion of the Contract.

Designate in writing a competent, English-speaking Superintendent employed by the Contractor. The Superintendent must be experienced with the work being performed and capable of reading and understanding the Contract. Ensure the Superintendent is available at all times and able to receive instructions from the Engineer or authorized Department representatives and to act for the Contractor. The Engineer may suspend work without suspending working day charges if a Superintendent is not available or does not meet the above criteria.

At the written request of the Engineer, immediately remove from the project any employee or representative of the Contractor or a subcontractor who, in the opinion of the Engineer, does not perform work in a proper and skillful manner or who is disrespectful, intemperate, disorderly, uncooperative, or otherwise objectionable. Do not reinstate these individuals without the written consent of the Engineer.

Furnish suitable machinery, equipment, and construction forces for the proper prosecution of the work. Provide adequate lighting to address quality requirements and inspection of nighttime work.

6. COOPERATING WITH UTILITIES

Use established safety practices when working near utilities. Consult with the appropriate utilities before beginning work. Notify the Engineer immediately of utility conflicts. The Engineer will decide whether to adjust utilities or adjust the work to eliminate or lessen the conflict. Unless otherwise shown on the plans, the Engineer will make necessary arrangements with the utility owner when utility adjustments are required.

Use work procedures that protect utilities or appurtenances that remain in place during construction. Cooperate with utilities to remove and rearrange utilities to avoid service interruption or duplicate work by the utilities. Allow utilities access to the right of way.

Immediately notify the appropriate utility of service interruptions resulting from damage due to construction activities. Cooperate with utilities until service is restored. Maintain access to fire hydrants when necessary.

7. COOPERATION BETWEEN CONTRACTORS

Cooperate and coordinate with other Contractors working within the limits or adjacent to the limits.

8. COOPERATION WITH RAILROADS

Plan and prosecute portions of the work involving a railway to avoid interference with or hindrance to the railroad company.

If the work is on railroad right of way, do not interfere with the operation of the railroad company's trains or other property.

8.1. **Railroad Coordination Meeting.** When shown on the plans or directed by the Engineer, schedule and attend a railroad coordination meeting with the Engineer before beginning work or as agreed (may be a part of the preconstruction conference described in Article 4.2., "Preconstruction Conference"). Prepare a list of attendees and invite personnel that includes but is not limited to Department, Contractor, subcontractor, and railroad representatives.

Provide the invite to the railroad representatives at least 21 calendar days before the railroad coordination meeting.

8.2. **Project-Specific Information.** Refer to project-specific plan sheets in the Contract for specific information concerning the work to be completed by both the Contractor and the railroad within railroad right of way; railroad right of way locations impacted by construction; percentage of contract work at each location; train movements at each location; and requirements for railroad insurance, flagging, and Right of Entry (ROE) Agreements.

8.3. **Right of Entry Agreement by the Department.** When shown on the plans, the process for obtaining a fully executed ROE Agreement is as follows:

- The Department will send the unexecuted ROE Agreement to the Contractor with the unexecuted Contract.
- Partially execute the ROE Agreement and return it to the Department with the partially executed Contract and required insurance.
- The Department will coordinate with the railroad company regarding the further execution of the ROE Agreement and associated fees. The Department will pay any ROE Agreement fees directly to the railroad company.
- Once the Department has received the fully-executed ROE Agreement from the railroad company, the Department will forward the fully-executed ROE Agreement to the Contractor.

8.4. **Right of Entry Agreement by the Contractor.** When shown on the plans, contact the railroad company to obtain the ROE Agreement before beginning work on the Contract.

Provide the required insurance to the Department before beginning work on the Contract.

Execute the ROE Agreement and pay any associated fees to the railroad company. Provide a copy of the fully-executed ROE Agreement to the Department.

9. CONSTRUCTION SURVEYING

Use Method C unless otherwise specified in the Contract. Upon request, the Engineer will allow the Contractor to copy available earthwork cross-sections, computer printouts or data files, and other information necessary to establish and control work. Maintain the integrity of control points. Preserve all control points, stakes, marks, and right of way markers. Assume cost and responsibility of replacing disturbed control points, stakes, marks, and right of way markers damaged by the Contractor's or its subcontractor operations.

If the Department repairs disturbed control points, stakes, marks, or right of way markers, the cost of repair may be deducted from money due or to become due to the Contractor. Replace right of way markers under the direction of a RPLS. This work performed under this Article will not be measured or paid for directly but will be considered subsidiary to pertinent Items.

The Engineer reserves the right to make measurements and surveys to determine the accuracy of the work and determine pay quantities. The Engineer's measurements and surveys do not relieve the Contractor's responsibility for accuracy of work. Allow the Engineer adequate time to verify the surveying.

- 9.1. **Method A.** The Engineer will set control points for establishing lines, slopes, grades, and centerlines and for providing both vertical and horizontal control.

At a minimum, provide a controlling pair of monument points at both the beginning and end of construction project for projects less than 2 mi. in length. For projects greater than 2 mi. in length, monuments will be set in pairs of 2 at a minimum of 2 mi. based on the overall length of the project. Use these control points as reference to perform the work.

Furnish materials, equipment, and qualified workforce necessary for the construction survey work. Place construction points, stakes, and marks at intervals sufficient to control work to established tolerances. Place construction stakes at intervals of no more than 100 ft., or as directed. Place stakes and marks so as not to interfere with normal maintenance operations.

- 9.2. **Method B.** The Engineer will set adequate control points, stakes, and marks to establish lines, slopes, grades, and centerlines. Furnish additional work, stakes, materials, and templates necessary for marking and maintaining points and lines.

- 9.3. **Method C.** Set adequate control points, stakes, and marks to establish lines, slopes, grades, and centerlines.

10. INSPECTION

Inspectors are authorized representatives of the Engineer. Inspectors are authorized to examine all work performed and materials furnished, including preparation, fabrication, and material manufacture. Inspectors inform the Contractor of failures to meet Contract requirements. Inspectors may reject work or materials and may suspend work until any issues can be referred to and decided by the Engineer. Inspectors cannot alter, add, or waive Contract provisions, issue instructions contrary to the Contract, act as foremen for the Contractor, or interfere with the management of the work. Inspection or lack of inspection will not relieve the Contractor from obligation to provide materials or perform the work in accordance with the Contract.

Provide safe access to all parts of the work and provide information and assistance to the Engineer to allow a complete and detailed inspection. Give the Engineer sufficient notice to inspect the work. Work performed without suitable inspection, as determined by the Engineer, may be ordered removed and replaced at Contractor's expense. Remove or uncover portions of finished work as directed. Once inspected, restore work to Contract requirements. If the uncovered work is acceptable, the costs to uncover, remove, and replace or make good the parts removed will be paid for in accordance with Article 4.4., "Changes in the Work." If the work is unacceptable, assume all costs associated with repair or replacement, including the costs to uncover, remove, and replace or make good the parts removed.

When a government entity, utility, railroad company, or other entity accepts or pays a portion of the Contract, that organization's representatives may inspect the work but cannot direct the Contractor. The right of inspection does not make that entity a party to the Contract and does not interfere with the rights of the parties to the Contract.

11. FINAL CLEANUP

Upon completion of the work, remove litter, debris, objectionable material, temporary structures, excess materials, and equipment from the work locations. Clean and restore property damaged by the Contractor’s operations during the prosecution of the work. Leave the work locations in a neat and presentable condition.

Remove from the right of way cofferdams, construction buildings, material and fabrication plants, temporary structures, excess materials, and debris resulting from construction. Where work is in a stream, remove debris to the ground line of the bed of the stream. Leave stream channels and rights of way in a neat and presentable condition. Clean structures to the flow line or the elevation of the outfall channel, whichever is higher. Dispose of all excess material in accordance with federal, state, and local regulations.

The work performed under this Article will not be paid for directly but will be considered subsidiary to Items of the Contract.

12. FINAL ACCEPTANCE

12.1. **Routine Maintenance Contracts.** The Engineer will perform final acceptance and notify the Contractor of acceptance. The Engineer may use final acceptance procedures shown for construction Contracts.

12.2. **Construction Contracts.** Final acceptance is made when all work is complete and the Engineer, in writing, accepts all work for the work locations in the Contract. Final acceptance relieves the Contractor from further Contract responsibilities.

12.2.1. **Work Completed.** Work completed must include work for vegetative establishment and maintenance, test, and performance periods and work to meet the requirements of Article 5.11., “Final Cleanup.”

12.2.2. **Final Inspection.** After all work is complete, the Engineer in charge of the work will request a final inspection by the Engineer authorized to accept the work.

The final inspection will be made as soon as possible and not later than 10 calendar days after the request. No working day charges will be made between the date of request and final inspection.

After the final inspection, if the work is satisfactory, the Engineer will notify the Contractor in writing of the final acceptance of the work. If the final inspection finds any work to be unsatisfactory, the Engineer will identify in writing all deficiencies in the work requiring correction. Correct the deficiencies identified. Working day charges will resume if these deficiencies are not corrected within 7 calendar days, unless otherwise authorized by the Engineer. Upon correction, the Engineer will make an inspection to verify that all deficiencies were corrected satisfactorily. The Engineer will provide written notice of the final acceptance.

12.2.3. **Final Measurement.** Final measurements and pay quantity adjustments may be made after final acceptance.

12.2.4. **Removal of Traffic Control Devices.** Remove construction traffic control devices and advance warning signs upon final acceptance or as directed.

12.3. **Multiple Work Orders.** For Contracts with multiple work orders, final acceptance may be made upon completion of the work for each work order, in accordance with Section 5.12.1., “Routine Maintenance Contracts.”

Item 6

Control of Materials



1. SOURCE CONTROL

Use only materials that meet Contract requirements. Unless otherwise specified or approved, use new materials for the work. Secure the Engineer’s approval of the proposed source of materials to be used before their delivery. Materials can be approved at a supply source or staging area but may be inspected in accordance with Article 6.4., “Sampling, Testing, and Inspection.”

- 1.1. **Buy America.** Comply with the latest provisions of Buy America as listed at 23 CFR 635.410. Use steel or iron materials manufactured in the United States except when:
- the cost of materials, including delivery, does not exceed 0.1% of the total Contract cost or \$2,500, whichever is greater,
 - the Contract contains an alternate item for a foreign source steel or iron product and the Contract is awarded based on the alternate item, or
 - the materials are temporarily installed.

Submit a notarized original of the FORM D-9-USA-1 (Department Form 1818) with the proper attachments for verification of compliance.

Manufacturing is any process that modifies the chemical content, physical shape or size, or final finish of a product. Manufacturing begins with initial melting and mixing and continues through fabrication (cutting, drilling, welding, bending, etc.) and coating (paint, galvanizing, epoxy, etc.).

- 1.2. **Buy Texas.** For construction or maintenance Contracts without federal funds, buy materials produced in Texas when the materials are available at a comparable price and in a comparable period of time. Provide documentation of purchases or a description of good-faith efforts on request.

2. MATERIAL QUALITY

Correct or remove materials that fail to meet Contract requirements or that do not produce satisfactory results. Reimburse the Department for cost incurred if additional sampling and testing is required by a change of source.

Materials not meeting Contract requirements will be rejected, unless the Engineer approves corrective actions. Upon rejection, immediately remove and replace rejected materials.

If the Contractor does not comply with this Article, the Department may remove and replace defective material. The cost of testing, removal, and replacement will be deducted from the payments due to the Contractor.

3. MANUFACTURER WARRANTIES

Transfer to the Department warranties and guarantees required by the Contract or received as part of normal trade practice.

4. SAMPLING, TESTING, AND INSPECTION

Incorporate into the work only material that has been inspected, tested, and accepted by the Department. Remove, at the Contractor's expense, materials from the work locations that are used without prior testing and approval or written permission of the Engineer.

The material requirements and standard test methods in effect at the time the proposed Contract is advertised govern. Unless otherwise noted, the Department will perform testing at its expense. In addition to facilities and equipment required by the Contract, furnish facilities and calibrated equipment required for tests to control the manufacture of construction items. If requested, provide a complete written statement of the origin, composition, and manufacture of materials.

All materials used are subject to inspection or testing at any time during preparation or use. Material which has been tested and approved at a supply source or staging area may be inspected or tested before or during incorporation into the work, and rejected if it does not meet Contract requirements. Copies of test results are available upon request. Do not use material that, after approval, becomes unfit for use.

Unless otherwise noted in the Contract, all testing must be performed within the United States and witnessed by the Engineer. If materials or processes require testing outside the contiguous 48 United States, reimburse the Department for inspection expenses.

5. PLANT INSPECTION AND TESTING

The Engineer may but is not obligated to inspect materials at the acquisition or manufacturing source. Material samples will be obtained and tested for compliance with quality requirements. Materials produced under Department inspection are for Department use only unless released in writing by the Engineer.

If inspection is at the plant, meet the following conditions unless otherwise specified:

- cooperate fully and assist the Engineer during the inspection,
- ensure the Engineer has full access to all parts of the plant used to manufacture or produce materials,
- provide a facility at the plant for use by the Engineer as an office or laboratory,
- provide and maintain adequate safety measures and restroom facilities, and
- furnish and calibrate scales, measuring devices, and other necessary equipment.

The Engineer may provide inspection for periods other than daylight hours if:

- continuous production of materials for Department use is necessary due to the production volume being handled at the plant, and
- the lighting is adequate to allow satisfactory inspection.

6. STORAGE OF MATERIALS

Store and handle materials to preserve their quality and fitness for the work. Store materials so that they can be easily inspected and retested. Place materials under cover, on wooden platforms, or on other hard, clean surfaces as necessary or when directed.

Obtain approval to store materials on the right of way. Storage space off the right of way is at the Contractor's expense.

7. DEPARTMENT-FURNISHED MATERIAL

The Department will supply materials as shown on the plans. The cost of handling and placing materials supplied by the Department will not be paid for directly but will be subsidiary to the Item in which they are used. Assume responsibility for materials upon receipt.

8. USE OF MATERIALS FOUND ON THE RIGHT OF WAY

Material found in the excavation areas and meeting the Department's specifications may be used in the work. This material will be paid for at the Contract bid price for excavation and under the Item for which the material is used.

Do not excavate or remove any material from within the right of way that is not within the limits of the excavation without written permission. If excavation is allowed within a right of way project-specific location, replace the removed material with suitable material at no cost to the Department as directed.

9. RECYCLED MATERIALS

The Department will not allow hazardous wastes, as defined in 30 TAC 335, proposed for recycling. Use nonhazardous recyclable materials (NRMs) only if the specification for the Item does not disallow or restrict use. Determine if NRMs are regulated under 30 TAC 312, 330, 332, 334, or 335, and comply with all general prohibitions and requirements. Use NRMs in accordance with DMS-11000, "Evaluating and Using Nonhazardous Recyclable Materials Guidelines," and furnish all documentation in the manner prescribed by the Department.

10. HAZARDOUS MATERIALS

Comply with the requirements of Article 7.12., "Responsibility for Hazardous Materials."

The Department is responsible for testing, removing, and disposing of hazardous materials not introduced by the Contractor, except for paint removal associated with Item 446, "Field Cleaning and Painting Steel," Item 776, "Metal Rail Repair," and Item 784, "Steel Member Repair." The plans will indicate locations where paint on steel is suspected to contain hazardous materials. The Engineer may suspend work wholly or in part during the testing, removing, or disposing of hazardous materials, except in the case where hazardous materials are introduced by the Contractor.

Use materials that are free of hazardous materials. Notify the Engineer immediately if materials are suspected to contain hazardous materials. If materials delivered to the project by the Contractor are suspected to contain hazardous materials, have an approved commercial laboratory test the materials for contamination. Remove, remediate, and dispose of any of these materials found to be contaminated. The work required to comply with this section will be at the Contractor's expense. Working day charges will not be suspended and extensions of working days will not be granted for activities related to handling hazardous material introduced by the Contractor.

10.1. **Painted Steel Requirements.** Paint containing hazardous materials will be removed as shown on the plans.

10.1.1. **Paint Removed by Third Party.** The Department will provide a third party to remove paint containing hazardous materials where paint must be removed to perform work when dismantling steel under Item 496, "Removing Structures."

10.1.2. **Paint Removed by the Contractor.** This work may only be performed by a firm or company with one of the following certifications unless otherwise shown on the plans:

- SSPC-QP2 Category A certification for lead painting operations, or
- Certified Lead Firm by the Texas Department of State Health Services.

Maintain certifications for the duration of the Contract. Provide copies of audits and certification to the Engineer.

Comply with worker and public safety regulations including but not limited to 29 CFR Parts 1910, 1925, and 1926. Monitor permissible exposure limits in accordance with OSHA requirements.

Remove paint containing hazardous materials from designated areas shown on the plans or as directed by the Engineer. Comply with access limitations shown on the plans.

Provide power hand tools, equipped with high-efficiency particulate air filter vacuums to mechanically remove paint unless otherwise approved.

Contain, collect, store, transport, and dispose of all waste generated by cleaning operation in accordance with local, state and federal requirements including 40 CFR 302. Properly characterize and dispose of all wastes. Manage wastes in accordance with regulatory requirements and dispose in a facility authorized to accept such wastes. Provide copies of disposal manifests to the Engineer.

Refer to Item 446, "Field Cleaning and Painting Steel" for measurement and payment.

- 10.2. **Removal and Disposal of Painted Steel.** Painted steel will be disposed of at a steel recycling or smelting facility unless otherwise shown on the plans. If the paint contains hazardous materials, maintain and make available to the Engineer invoices and other records obtained from the facility showing the received weight of the steel and the facility name.

Refer to Item 496, "Removing Structures" and Item 497, "Sale of Salvageable Material" for measurement and payment.

- 10.3. **Asbestos Requirements.** The plans will indicate locations or elements where asbestos containing materials (ACM) are present. Notify the Engineer of proposed dates of demolition or removal of structural elements with ACM at least 60 days before beginning work.

The Department of State Health Services (DSHS), Asbestos Programs Branch, is responsible for administering the requirements of the National Emissions Standards for Hazardous Air Pollutants, 40 CFR Part 61, Subpart M and the Texas Asbestos Health Protection Rules (TAHPR). Based on EPA guidance and regulatory background information, bridges are considered to be a regulated "facility" under NESHP. Therefore, federal standards for demolition and renovation apply.

The Department is required to notify the DSHS at least 10 working days (by postmarked date) before initiating demolition or renovation of each structure or load bearing member shown on the plans. If the actual demolition or renovation date is changed or delayed, notify the Engineer in writing of the revised dates in sufficient time to allow for the Department's notification to DSHS to be postmarked at least 10 days in advance of the actual work.

Failure to provide the above information may require the temporary suspension of work under Article 8.4., "Temporary Suspension of Work or Working Day Charges," due to reasons under the control of the Contractor. The Department retains the right to determine the actual advance notice needed for the change in date to address post office business days and staff availability.

- 10.3.1. **Asbestos Removed by Third Party.** At locations where unknown ACM is discovered, the Department will arrange for abatement by a third party.

- 10.3.2. **Asbestos Removed by the Contractor.** Maintain certification as Asbestos Abatement Contractor by the Texas Department of State Health Services for the duration of the Contract. Provide copies of audits and certification to the Engineer.

- 10.4. **Work Performed by a Third Party.** When the work for removal of paint or asbestos abatement is to be provided by a third party, coordinate and cooperate with the third party and the Department. Continue other work detailed in the plans not directly involved in the paint removal or asbestos abatement work. Provide notice to the Department regarding the progress of the work to allow the Department sufficient time to schedule the third party work.

11. SURPLUS MATERIALS

Take ownership of surplus materials unless otherwise shown on the plans or directed. Remove and dispose of materials in accordance with federal, state, and local regulations. If requested, provide an appropriate level of documentation to verify proper disposal. When materials are disposed of on private property, provide written authorization from the property owner for the use of the property for this purpose upon request.

Item 7

Legal Relations and Responsibilities



1. ETHICS

Honor the Department's ethics policy. The Department's ethics policy has been established in accordance with Title 43 of the Texas Administrative Code, Part 1, Chapter 10. A complete copy of the Department's ethics policy can be found on the Department's website.

By entering into Contract, the Contractor certifies that the Contractor has read and understands the Department's ethics policy.

Failure to honor this policy may result in action by the Department, which includes but is not limited to verbal warning, removal of project personnel, termination of the Contract, and sanctions under the Texas Administrative Code.

2. SAFETY

- 2.1. **Safety Point of Contact.** Designate in writing, a Contractor Safety Point of Contact (CSPOC). The Department will assign a Department employee for their point of contact designated as DSPOC. The CSPOC will ensure that the Contractor's and Subcontractor's employees' use the appropriate personal protection equipment (hard hats, safety vests, protective toe footwear, etc.).

The CSPOC will ensure that crew leaders and foremen (including subcontractors) have attended the required training.

- 2.2. **Safety Preconstruction Meeting.** In cooperation with the Engineer, schedule and attend a safety preconstruction meeting (may be a part of the preconstruction conference in Article 4.2., "Preconstruction Conference"). Attendees for this safety preconstruction meeting will be:

- the Contractor,
- subcontractors,
- Department,
- local law enforcement, and
- other personnel that play an active role on the project.

- 2.3. **Safety Contingency.** In order to improve the effectiveness of traffic handling and enhancing safety during the course of this project, a safety contingency fund may have been included in the project budget for traffic control plan adjustments and other safety-related improvements.

Costs associated with the adjustments or improvements will be paid for in accordance with Article 9.7., "Payment for Extra Work and Force Account Method." Article 9.7., "Payment for Extra Work and Force Account Method" is not intended to be used in lieu of bid items established by the Contract.

- 2.4. **Public Safety and Convenience.** Ensure the safety and convenience of the public and property as provided in the Contract and as directed. Keep existing roadways open to traffic or construct and maintain detours and temporary structures for safe public travel. Manage construction to minimize disruption to traffic. Maintain the roadway in a good and passable condition, including proper drainage and provide for ingress and egress to adjacent property.

Store all equipment not in use in a manner and at locations that will not interfere with the safe passage of traffic.

If the Engineer determines that any of the requirements of this Article have not been met, the Engineer may take corrective action. This will not change the legal responsibilities set forth in the Contract. The cost to the Department for this work will be deducted from any money due or to become due to the Contractor.

- 2.5. **Use of Blue Warning Lights.** Texas Transportation Code 547.105 authorizes the use of warning lights to promote safety and provides an effective means of gaining the travelling public's attention as they drive in areas where construction crews are present. In order to influence the public to move over when high risk construction activities are taking place, minimize the utilization of blue warning lights. These lights must be used only while performing work on or near the travel lanes or shoulder where the travelling public encounters construction crews that are not protected by a standard work zone set up such as a lane closure, shoulder closure, or one-way traffic control. Refrain from leaving the warning lights engaged while travelling from one work location to another or while parked on the right of way away from the pavement or a work zone.
- 2.6. **Barricades, Signs, and Traffic Handling.** Comply with the requirements of Item 502 "Barricades, Signs, and Traffic Handling," and as directed. Provide traffic control devices that conform to the details shown on the plans, the TMUTCD, and the Department's Compliant Work Zone Traffic Control Device List (CWZTCDL) maintained by the Traffic Operations Division. In cases of disagreement between these documents, the CWZTDL governs over the plans, and the TMUTCD governs over both the CWZTDL and the plans. When authorized or directed, provide additional signs or traffic control devices not required by the plans.
- If an unexpected situation arises that causes the Contractor to believe that the traffic control should be changed, make all reasonable efforts to promptly contact the Engineer. Take prudent actions until the Engineer can be contacted.
- The Engineer will make an inspection of the traffic control devices. Comply with the results of the inspection in the prescribed time frame.
- The work performed and materials furnished in accordance with this section and Item 502 have no bearing on the prosecution of Items 1 through 9, "General Requirements and Covenants" of the Contract. This includes, but is not limited to installing, relocating, and removing project limit advance warning signs.
- 2.6.1. **Contractor Responsible Person and Alternate.** Designate in writing, a Contractor's Responsible Person (CRP) and an alternate to be the representative of the Contractor who is responsible for taking or directing corrective measures regarding the traffic control. The CRP or alternate must be accessible by phone 24 hr. per day and able to respond when notified. The CRP and alternate must comply with the requirements of Section 7.2.6.5., "Training."
- 2.6.2. **Flaggers.** Designate in writing, a flagger instructor who will serve as a flagging supervisor and is responsible for training and assuring that all flaggers are qualified to perform flagging duties. Before beginning work, provide a list of flaggers certified to perform flagging duties.
- Provide flaggers as directed. Flaggers must be courteous and able to effectively communicate with the public. When directing traffic, flaggers must dress appropriately, wear high-visibility safety apparel, use flags, signs, stop-slow paddles, and other hand-signaling devices, and follow the flagging procedures in the TMUTCD. Comply with the requirements of Section 7.2.6.5., "Training."
- 2.6.3. **Law Enforcement Personnel.** Provide uniformed law enforcement personnel with patrol vehicles as directed. Document the work zone traffic services provided in the manner prescribed by the Department. Law enforcement personnel providing work zone traffic services must be trained for the service they perform. Comply with Section 7.2.6.5., "Training."
- 2.6.4. **Other Work Zone Personnel.** Workers involved with traffic control, including the maintenance of the traffic control, must comply with the requirements of Section 7.2.6.5., "Training."

- 2.6.5. **Training.** Workers involved with the traffic control must be trained using Department-approved training, except in the case of Section 7.2.6.4, "Other Work Zone Personnel" who may be trained using Contractor-developed Training in lieu of Department-approved Training.

Provide a copy of the certification of completion to the Engineer, except in the case of Contractor-developed Training. Ensure the certification of completion includes the following:

- name of provider and course title,
- name of participant,
- date of completion, and
- date of expiration.

For Contractor developed-Training, maintain a log of attendees. Make the log available upon request. Ensure the log is legible and includes the following:

- print name and signature of participant,
- name and title of trainer, and
- date of training.

3. LAWS TO BE OBSERVED

Comply with all federal, state, and local laws, ordinances, and regulations that affect the performance of the work. The Contractor is not required to comply with city electrical ordinances not included in this Contract. Indemnify and save harmless the State and its representatives against any claim arising from violation by the Contractor of any law, ordinance, or regulation.

This Contract is between the Department and the Contractor only. No person or entity may claim third-party beneficiary status under this Contract or any of its provisions, nor may any non-party sue for personal injuries or property damage under this Contract.

4. PERMITS, LICENSES, AND TAXES

Procure all permits and licenses; pay all charges, fees, and taxes; and give all notices necessary and incidental to the due and lawful prosecution of work, except for permits provided by the Department and as specified in Article 7.7., "Preservation of Cultural and Natural Resources and the Environment."

5. PATENTED DEVICES, MATERIAL, AND PROCESSES

Indemnify and save harmless the State from any claims for infringement from the Contractor's use of any patented design, device, material, process, trademark, or copyright selected by the Contractor and used in connection with the work. Indemnify and save harmless the State against any costs, expenses, or damages that it may be obliged to pay, by reason of this infringement, at any time during the prosecution or after the completion of the work.

6. PERSONAL LIABILITY OF PUBLIC OFFICIALS

Department employees are agents and representatives of the State and will incur no liability, personal or otherwise, in carrying out the provisions of the Contract or in exercising any power or authority granted under the Contract.

7. PRESERVATION OF CULTURAL AND NATURAL RESOURCES AND THE ENVIRONMENT

- 7.1. **Cultural Resources.** Cease all work immediately if a site, building, or location of historical, archeological, educational, or scientific interest is discovered within the right of way. The site, building, or location will be investigated and evaluated by the Department.
- 7.2. **Texas Pollutant Discharge Elimination System (TPDES) Permits and Storm Water Pollution Prevention Plans (SWP3).** The Department will file the Notice of Intent (NOI) and the Notice of Termination (NOT) for work shown on the plans in the right of way. Adhere to all requirements of the SWP3.
- 7.3. **Work in Waters of the United States.** For work in the right of way, the Department will obtain any required Section 404 permits from the U.S. Army Corps of Engineers before work begins. Adhere to all agreements, mitigation plans, and standard best management practices required by the permit. When Contractor-initiated changes in the construction method changes the impacts to waters of the U.S., obtain new or revised Section 404 permits.
- 7.4. **Work in Navigable Waters of the United States.** For work in the right of way, the Department will obtain any required Section 9 permits from the U.S. Coast Guard before work begins. Adhere to the stipulations of the permits and associated best management practices. When Contractor-initiated changes in the construction method changes the impacts to navigable waters of the U.S., obtain new or revised Section 9 permits.
- 7.5. **Work Over the Recharge or Contributing Zone of Protected Aquifers.** Make every reasonable effort to minimize the degradation of water quality resulting from impacts relating to work over the recharge or contributing zones of protected aquifers, as defined and delineated by the TCEQ. Use best management practices and perform work in accordance with Contract requirements.
- 7.6. **Project-Specific Locations.** For all project-specific locations (PSLs) on or off the right of way (material sources, waste sites, parking areas, storage areas, field offices, staging areas, haul roads, etc.), signing the Contract certifies compliance with all applicable laws, rules, and regulations pertaining to the preservation of cultural resources, natural resources, and the environment as issued by the following or other agencies:
- Occupational Safety and Health Administration,
 - Texas Commission on Environmental Quality,
 - Texas Department of Transportation,
 - Texas Historical Commission,
 - Texas Parks and Wildlife Department,
 - Texas Railroad Commission,
 - U.S. Army Corps of Engineers,
 - U.S. Department of Energy,
 - U.S. Department of Transportation,
 - U.S. Environmental Protection Agency,
 - U.S. Federal Emergency Management Agency, and
 - U.S. Fish and Wildlife Service.

All subcontractors must also comply with applicable environmental laws, rules, regulations, and requirements in the Contract. Maintain documentation of certification activities including environmental consultant reports, Contractor documentation on certification decisions and contacts, and correspondence with the resource agencies. Provide documentation upon request.

Obtain written approval from the Engineer for all PSLs in the right of way not specifically addressed on the plans. Prepare an SWP3 for all Contractor facilities, such as asphalt or concrete plants located within Department right of way. Comply with all TCEQ permit requirements for portable facilities, such as concrete batch plants, rock crushers, asphalt plants, etc. Address all environmental issues, such as Section 404

permits, wetland delineation, endangered species consultation requirements, or archeological and historic site impacts. Obtain all permits and clearances in advance.

- 7.7. **Contractor Responsibility.** If the Contractor initiates changes to the Contract and the Department approves the changes, the Contractor is responsible for obtaining clearances and coordinating with the appropriate regulatory agencies.

8. AGRICULTURAL IRRIGATION

Regulate the sequence of work and make provisions as necessary to provide for agricultural irrigation or drainage during the work. Meet with the service provider or land owner to determine the proper time and sequence when irrigation demands will permit shutting-off water flows to perform work.

Unless otherwise provided on the plans, the work performed under this Article will not be measured or paid for directly but will be subsidiary to pertinent Items.

9. SANITARY PROVISIONS

Provide and maintain adequate, neat, and sanitary toilet accommodations for employees, including State employees, in compliance with the requirements and regulations of the Texas Department of Health or other authorities having jurisdiction.

10. ABATEMENT AND MITIGATION OF EXCESSIVE OR UNNECESSARY NOISE

Minimize noise throughout all phases of the Contract. Exercise particular and special efforts to avoid the creation of unnecessary noise impact on adjacent noise sensitive receptors in the placement of non-mobile equipment such as air compressors, generators, pumps, etc. Place mobile and stationary equipment to cause the least disruption of normal adjacent activities.

All equipment associated with the work must be equipped with components to suppress excessive noise and these components must be maintained in their original operating condition considering normal depreciation. Noise-attenuation devices installed by the manufacturer such as mufflers, engine covers, insulation, etc. must not be removed nor rendered ineffectual nor be permitted to remain off the equipment while the equipment is in use.

11. USING EXPLOSIVES

Do not endanger life or property. When required by the plans or requested, provide a written blasting plan. The Department retains the right to reject the blasting plan. Store all explosives securely and clearly mark all storage places with "DANGER – EXPLOSIVES." Store, handle, and use explosives and highly flammable material in compliance with federal, state, and local laws, ordinances, and regulations. Assume liability for property damage, injury, or death resulting from the use of explosives.

Give at least a 48-hr. advance notice to the appropriate railroad representative before doing any blasting work involving the use of electric blasting caps within 200 ft. of any railroad track.

12. RESPONSIBILITY FOR HAZARDOUS MATERIALS

Comply with the requirements of Article 6.10., "Hazardous Materials". Indemnify and save harmless the State and its agents and employees from all suits, actions, or claims and from all liability and damages for any injury or damage to any person or property arising from the generation or disposition of hazardous materials introduced by the Contractor on any work done by the Contractor on State-owned or controlled sites. Indemnify and save harmless the State and its representatives from any liability or responsibility arising out of the Contractor's generation or disposition of any hazardous materials obtained, processed, stored,

shipped, etc., on sites not owned or controlled by the State. Reimburse the State for all payments, fees, or restitution the State is required to make as a result of the Contractor's actions.

13. RESTORING SURFACES OPENED BY PERMISSION

Do not authorize anyone to make an opening in the highway for utilities, drainage, or any other reason without written permission from the Engineer. Repair all openings as directed. Payment for repair of surfaces opened by permission will be made in accordance with pertinent Items or Article 4.4., "Changes in the Work." Costs associated with openings made with Contractor authorization but without Department approval will not be paid.

14. PROTECTING ADJACENT PROPERTY

Protect adjacent property from damage. If any damage results from an act or omission on the part of or on behalf of the Contractor, take corrective action to restore the damaged property to a condition similar or equal to that existing before the damage was done.

15. RESPONSIBILITY FOR DAMAGE CLAIMS

Indemnify and save harmless the State and its agents and employees from all suits, actions, or claims and from all liability and damages for any injury or damage to any person or property due to the Contractor's negligence in the performance of the work and from any claims arising or amounts recovered under any laws, including workers' compensation and the Texas Tort Claims Act. Indemnify and save harmless the State and assume responsibility for all damages and injury to property of any character occurring during the prosecution of the work resulting from any act, omission, neglect, or misconduct on the Contractor's part in the manner or method of executing the work; from failure to properly execute the work; or from defective work or material.

Pipelines and other underground installations that may or may not be shown on the plans may be located within the right of way. Indemnify and save harmless the State from any suits or claims resulting from damage by the Contractor's operations to any pipeline or underground installation. Make available the scheduled sequence of work to the respective utility owners so that they may coordinate and schedule adjustments of their utilities that conflict with the proposed work.

If the Contractor asserts any claim or brings any type of legal action (including an original action, third-party action, or cross-claim) against any member of the Commission or individual employee of the Department for any cause of action or claim for alleged negligence arising from the Contract, the Contractor will be ineligible to bid on any proposed Contract with the Department during the pendency of the claim or legal action.

16. HAULING AND LOADS ON ROADWAYS AND STRUCTURES

Comply with federal and state laws concerning legal gross and axle weights. Except for the designated Interstate system, vehicles with a valid yearly overweight tolerance permit may haul materials to the work locations at the permitted load. Provide copies of the yearly overweight tolerance permits to the Engineer upon request. Construction equipment is not exempt from oversize or overweight permitting requirements on roadways open to the traveling public.

Protect existing bridges and other structures that will remain in use by the traveling public during and after the completion of the Contract. Construction traffic on roadways, bridges, and culverts within the limits of the work, including any structures under construction that will remain in service during and after completion of the Contract is subject to legal size and weight limitations.

Additional temporary fill may be required by the Engineer for hauling purposes for the protection of certain structures. This additional fill will not be paid for directly but will be subsidiary to pertinent Items.

Replace or restore to original condition any structure damaged by the Contractor's operations.

The Engineer may allow equipment with oversize or non-divisible overweight loads to operate without a permit within the work locations on pavement structures not open to the traveling public. Submit Contractor-proposed changes to traffic control plans for approval, in accordance with Item 502, "Barricades, Signs, and Traffic Handling." The following sections further address overweight allowances. The Department will make available to the Contractor any available plans and material reports for existing structures.

- 16.1. **Overweight Construction Traffic Crossing Structures.** The Engineer may allow crossing of a structure not open to the public within the work locations, when divisible or non-divisible loads exceed legal weight limitations, including limits for load-posted bridges. Obtain written permission to make these crossings. Submit for approval a structural analysis by a licensed professional engineer indicating that the excessive loads should be allowed. Provide a manufacturer's certificate of equipment weight that includes the weight distribution on the various axles and any additional parts such as counterweights, the configuration of the axles, or other information necessary for the analysis. Submit the structural analysis and supporting documentation sufficiently in advance of the move to allow for review by the Engineer. Permission may be granted if the Engineer finds that no damage or overstresses in excess of those normally allowed for occasional overweight loads will result to structures that will remain in use after Contract completion. Provide temporary matting or other protective measures as directed.

Schedule loads so that only one vehicle is on any span or continuous unit at any time. Use barricades, fences, or other positive methods to prevent other vehicular access to structures at any time the overweight load is on any span or continuous unit.

- 16.2. **Construction Equipment Operating on Structures.** Cranes and other construction equipment used to perform construction operations that exceed legal weight limits may be allowed on structures. Before any operation that may require placement of equipment on a structure, submit for approval a detailed structural analysis prepared by a licensed professional engineer.

Submit the structural analysis and supporting documentation sufficiently in advance of the use to allow for review by the Engineer. Include all axle loads and configurations, spacing of tracks or wheels, tire loads, outrigger placements, center of gravity, equipment weight, and predicted loads on tires and outriggers for all planned movements, swings, or boom reaches. The analysis must demonstrate that no overstresses will occur in excess of those normally allowed for occasional overweight loads.

- 16.3. **Loads on Structures.** Do not store or stockpile material on bridge structures without written permission. If required, submit a structural analysis and supporting documentation by a licensed professional engineer for review by the Engineer. Permission may be granted if the Engineer finds that no damage or overstresses in excess of those normally allowed for occasional overweight loads will result to structures that will remain in use after Contract completion. Provide temporary matting or other protective measures as directed.

- 16.4. **Hauling Divisible Overweight Loads on Pavement Within the Work Locations.** The Engineer may allow divisible overweight loads on pavement structures within the work locations not open to the traveling public. Obtain written approval before hauling the overweight loads. Include calculations to demonstrate that there will be no damage or overstress to the pavement structure.

17. CONTRACTOR'S RESPONSIBILITY FOR WORK

Until final acceptance of the Contract, take every precaution against injury or damage to any part of the work by the action of the elements or by any other cause, whether arising from the execution or from the non-execution of the work. Protect all materials to be used in the work at all times, including periods of suspension.

When any roadway or portion of the roadway is in suitable condition for travel, it may be opened to traffic as directed. Opening of the roadway to traffic does not constitute final acceptance.

Repair damage to all work until final acceptance. Repair damage to existing facilities in accordance with the Contract or as directed by the Engineer. Repair damage to existing facilities or work caused by Contractor operations at the Contractor's expense. Repair work for damage that was not due to the Contractor's operations will not be paid for except as provided below.

- 17.1. **Reimbursable Repair.** Except for damage to appurtenances listed in Section 7.17.2.1., "Unreimbursed Repair," the Contractor will be reimbursed for repair of damage caused by:
- motor vehicle, watercraft, aircraft, or railroad-train incident,
 - vandalism, or
 - Acts of God, such as earthquake, tidal wave, tornado, hurricane, or other cataclysmic phenomena of nature.
- 17.2. **Appurtenances.**
- 17.2.1. **Unreimbursed Repair.** Except for destruction (not reusable) due to Acts of God, reimbursement will not be made for repair of damage to the following temporary appurtenances, regardless of cause:
- signs,
 - barricades,
 - changeable message signs, and
 - other work zone traffic control devices.
- Crash cushion attenuators and guardrail end treatments are reimbursed in accordance with Section 7.17.2.2., "Reimbursed Repair."
- Where the Contractor retains replaced appurtenances after completion of the project, the Department will limit the reimbursement to the cost that is above the salvage value at the end of the project.
- 17.2.2. **Reimbursed Repair.** Reimbursement will be made for repair of damage due to the causes listed in Section 7.17.1, "Reimbursable Repair."
- 17.3. **Roadways and Structures.** Until final acceptance, the Contractor is responsible for all work constructed under the Contract. The Department will not reimburse the Contractor for repair work to new construction, unless the failure or damage is due to one of the causes listed in Section 7.17.1, "Reimbursable Repair."
- The Department will be responsible for the cost for repair of damage to existing roadways and structures not caused by the Contractor's operations.
- 17.4. **Detours.** The Contractor will be responsible for the cost of maintenance of detours constructed under the Contract, unless the failure or damage is due to one of the causes listed in Section 7.17.1., "Reimbursable Repair." The Engineer may consider failures beyond the Contractor's control when determining reimbursement for repairs to detours constructed. The Department will be responsible for the cost of maintenance of existing streets and roadways used for detours or handling traffic.
- 17.5. **Relief from Maintenance.** The Engineer may relieve the Contractor from responsibility of maintenance as outlined in this Section. This relief does not release the Contractor from responsibility for defective materials or work or constitute final acceptance.
- 17.5.1. **Isolated Work Locations.** For isolated work locations, when all work is completed, including work for Article 5.11., "Final Cleanup," the Engineer may relieve the Contractor from responsibility for maintenance.
- 17.5.2. **Work Except for Vegetative Establishment and Test Periods.** When all work for all or isolated work locations has been completed, including work for Article 5.11., "Final Cleanup," with the exception of vegetative establishment and maintenance periods and test and performance periods, the Engineer may relieve the Contractor from responsibility for maintenance of completed portions of work.

- 17.5.3. **Work Suspension.** When all work is suspended for an extended period of time, the Engineer may relieve the Contractor from responsibility for maintenance of completed portions of work during the period of suspension.
- 17.5.4. **When Directed by the Engineer.** The Engineer may relieve the Contractor from the responsibility for maintenance when directed.
- 17.6. **Basis of Payment.** When reimbursement for repair work is allowed and performed, payment will be made in accordance with pertinent Items or Article 4.4., "Changes in the Work."

18. ELECTRICAL REQUIREMENTS

18.1. Definitions.

18.1.1. **Electrical Work.** Electrical work is work performed for:

- Item 610, "Roadway Illumination Assemblies,"
- Item 614, "High Mast Illumination Assemblies,"
- Item 616, "Performance Testing of Lighting Systems,"
- Item 617, "Temporary Roadway Illumination,"
- Item 618, "Conduit,"
- Item 620, "Electrical Conductors,"
- Item 621, "Tray Cable,"
- Item 622, "Duct Cable,"
- Item 628, "Electrical Services,"
- Item 680, "Highway Traffic Signals,"
- Item 681, "Temporary Traffic Signals,"
- Item 684, "Traffic Signal Cables,"
- Item 685, "Roadside Flashing Beacon Assemblies,"
- other Items that involve either the distribution of electrical power greater than 50 volts or the installation of conduit and duct banks,
- the installation of conduit and wiring associated with Item 624, "Ground Boxes" and Item 656, "Foundations for Traffic Control Devices," and
- the installation of the conduit system for communication and fiber optic cable.

Electrical work does not include the installation of communications or fiber optic cable, or the connections for low voltage and inherently power limited circuits such as electronic or communications equipment. Assembly and placement of poles, structures, cabinets, enclosures, manholes, or other hardware will not be considered electrical work as long as no wiring, wiring connections, or conduit work is done at the time of assembly and placement.

18.1.2. **Specialized Electrical Work.** Specialized electrical work is work that includes the electrical service and feeders, sub-feeders, branch circuits, controls, raceways, and enclosures for the following:

- pump stations,
- moveable bridges,
- ferry slips,
- motor control centers,
- facilities required under Item 504, "Field Office and Laboratory,"
- rest area or other public buildings,
- weigh-in-motion stations,
- electrical services larger than 200 amps,
- electrical services with main or branch circuit breaker sizes not shown in the Contract, and
- any 3-phase electrical power.

- 18.1.3. **Certified Person.** A certified person is a person who has passed the test from the Department’s course TRF450, “TxDOT Roadway Illumination and Electrical Installations,” or other courses as approved by the Traffic Operations Division. Submit a current and valid TRF certification upon request. Texas A&M Engineering Extension Service (TEEX) certifications for “TxDOT Electrical Systems” course will not be accepted.
- 18.1.4. **Licensed Electrician.** A licensed electrician is a person with a current and valid unrestricted master electrical license, or unrestricted journeyman electrical license that is supervised or directed by an unrestricted master electrician. An unrestricted master electrician need not be on the work locations at all times electrical work is being done, but the unrestricted master electrician must approve work performed by the unrestricted journeyman. Licensed electrician requirements by city ordinances do not apply to on state system work.
- The unrestricted journeyman and unrestricted master electrical licenses must be issued by the Texas Department of Licensing and Regulation or by a city in Texas with a population of 50,000 or greater that issues licenses based on passing a written test and demonstrating experience.
- The Engineer may accept other states’ electrical licenses. Submit documentation of the requirements for obtaining that license. Acceptance of the license will be based on sufficient evidence that the license was issued based on:
- passing a test based on the NEC similar to that used by Texas licensing officials, and
 - sufficient electrical experience commensurate with general standards for an unrestricted master and unrestricted journeyman electrician in the State of Texas.
- 18.2. **Work Requirements.** The qualifications required to perform electrical work and specialized electrical work are listed in Table 2.

Table 2
Work Requirements

Type of Work	Qualifications to Perform Work
Electrical work with plans	Licensed electrician, certified person, or workers directly supervised by a licensed electrician or certified person
Electrical work without plans	Licensed electrician or workers directly supervised by a licensed electrician
Specialized electrical work	Licensed electrician or workers directly supervised by a licensed electrician
Replace lamps, starting aids, and changing fixtures	Licensed electrician, certified person, or workers directly supervised by a licensed electrician or certified person
Conduit in precast section with approved working drawings	Inspection by licensed electrician or certified person
Conduit in cast-in-place section	Inspection by licensed electrician or certified person
All other electrical work (troubleshooting, repairs, component replacement,	Licensed electrician or workers directly supervised by a licensed electrician

“Directly supervised by a licensed electrician” means that a licensed electrician is physically present during all electrical work. “Directly supervised by a licensed electrician or certified person” means that a licensed electrician or certified person is physically present during all electrical work.

A non-certified person may install conduit in cast-in-place concrete sections if the work is verified by a certified person before concrete placement.

When the plans specify IMSA certification, the requirements of Table 2 will still apply to the installation of the conduit, ground boxes, electrical services, pole grounding, and electrical conductors installed under Item 620, "Electrical Conductors."

19. PAYROLLS

Ensure that employees, contract labor, and any subcontractor's employees are paid at least the predetermined wage rates shown on the Contract.

Payroll records must contain the information required by law. As an option, form WH-347, "Payroll" is provided by the U.S. Department of Labor.

Maintain payroll and related records during the course of the Contract and preserve these records for a period of 3 years following the completion of the Contract or as required by law.

19.1 **Minimum Wage Requirements for Federally Funded Contracts.** Comply with the requirements of FHWA-1273, "Required Contract Provisions Federal-Aid Construction Contracts."

Submit payroll records to the Engineer in the manner prescribed by the Department.

19.2 **Minimum Wage Requirements for State Funded Contracts.** Comply with the requirements of 29 USC 206 unless otherwise shown in the Contract.

Upon request, submit payroll records to the Engineer in the manner prescribed by the Department.

Item 8 Prosecution and Progress



1. PROSECUTION OF WORK

Begin work within 30 calendar days (7 calendar days for routine maintenance Contracts) after the authorization date to begin work. Prosecute the work continuously to completion within the working days specified. Unless otherwise shown on the plans, work may be prosecuted in concurrent phases if no changes are required to the traffic control plan or if a revised traffic control plan is approved. Notify the Engineer at least 24 hr. before beginning work or before beginning any new operation. Do not start new operations to the detriment of work already begun. Minimize interference to traffic.

For Contracts with callout work and work orders, begin work in the right of way within the specified time and continuously prosecute the work until completion.

2. SUBCONTRACTING

Do not sublet any portion of a construction Contract without the Engineer’s written approval. A subcontract does not relieve any responsibility under the Contract and bonds. Ensure that all subcontracted work complies with all governing labor provisions.

The Contractor certifies by signing the Contract that the Contractor will not enter into any subcontract with a subcontractor that is debarred or suspended by the Commission, Department, or any federal agency.

For federally funded contracts, ensure the required federal documents are physically attached to each subcontract agreement including all tiered subcontract agreements.

For all DBE subcontracts including all tiered DBE subcontracts, submit a copy of the executed subcontract agreement.

Upon request, submit a copy of the executed non-DBE subcontracts including all tiered non-DBE subcontracts..

2.1. **Construction Contracts and Federally Funded Maintenance Contracts.** Perform work with own organization on at least 30% of the total original Contract cost (25% if the Contractor is a Small Business Enterprise on a wholly State or local funded Contract), excluding any specialty items as determined by the Engineer. Specialty items are those that require highly specialized knowledge, abilities, or equipment not usually available in the contracting firm expected to bid on the proposed Contract as a whole.

Specialty items will be shown on the plans or as determined by the Engineer. Bid cost of specialty items performed by subcontractors will be deducted from the total original Contract cost before computing the required amount of work to be performed by the Contractor’s own organization.

The term “perform work with own organization” includes only:

- workers employed and paid directly by the Contractor or wholly owned subsidiary;
- equipment owned by the Contractor or wholly owned subsidiary;
- rented or leased equipment operated by the Contractor’s employees or wholly owned subsidiary’s employees;
- materials incorporated into the work if the majority of the value of the work involved in incorporating the material is performed by the Contractor’s own organization, including a wholly owned subsidiary’s organization; and

- labor provided by staff leasing firms licensed under Chapter 91 of the Texas Labor Code for nonsupervisory personnel if the Contractor or wholly owned subsidiary maintains direct control over the activities of the leased employees and includes them in the weekly payrolls.

When staff leasing firms provide materials or equipment, they are considered subcontractors. In these instances, submit staff leasing firms for approval as a subcontractor.

Copies of cancelled checks and certified statements may be required to verify compliance with the requirements of this Section.

- 2.2. **State Funded Maintenance Contracts.** The requirements for performing work with the Contractor's own organization as stated in Section 8.2.1, "Construction Contracts and Federally Funded Maintenance Contracts" do not apply to wholly State funded maintenance Contracts.
- 2.3. **Payments to Subcontractors.** Report payments for DBE subcontracts including tiered DBE subcontracts in the manner as prescribed by the Department by the 20th day of each month.
- 2.3.1 **Payment Records.** Make payment and related records, including but not limited to copies of cancelled checks, available for inspection by the Department. Retain payment records for a period of 3 years following the completion of the Contract.
- 2.4. **Payrolls.** Comply with Article 7.19., "Payrolls."

3. COMPUTATION OF CONTRACT TIME FOR COMPLETION

The number of working days is established by the Contract. For Contracts with work orders, the number of working days is established in each work order. Working day charges will begin when work begins as prescribed in Article 8.1., "Prosecution of Work." Working day charges will continue in accordance with the Contract.

Upon request, the Engineer will provide the conceptual time determination schedule to the Contractor for informational purposes only. The schedule assumes generic resources, production rates, sequences of construction and average weather conditions based on historic data. The Department will not adjust the number of working days and milestones, if any, due to differences in opinion regarding any assumptions made in the preparation of the schedule or for errors, omissions, or discrepancies found in the Department's conceptual time determination schedule.

- 3.1. **Working Day Charges.** Working days will be charged in accordance with Section 8.3.1.4., "Standard Workweek," unless otherwise shown on the plans. Working days will be computed and charged in accordance with one of the following:
- 3.1.1. **Five-Day Workweek.** Working days will be charged Monday through Friday, excluding national holidays, regardless of weather conditions or material availability. The Contractor has the option of working on Saturdays. Provide sufficient advance notice to the Engineer when scheduling work on Saturdays. Work on Sundays and national holidays will not be permitted without written permission of the Engineer. If work requiring an Inspector to be present is performed on a Saturday, Sunday, or national holiday, and weather and other conditions permit the performance of work for 7 hr. between 7:00 A.M. and 6:00 P.M., a working day will be charged.
- 3.1.2. **Six-Day Workweek.** Working days will be charged Monday through Saturday, excluding national holidays, regardless of weather conditions or material availability. Work on Sundays and national holidays will not be permitted without written permission of the Engineer. If work requiring an Inspector to be present is performed on a Sunday or a national holiday, and weather or other conditions permit the performance of work for 7 hr. between 7:00 A.M. and 6:00 P.M., a working day will be charged.

- 3.1.3. **Seven-Day Workweek.** Working days will be charged Monday through Sunday, excluding national holidays, regardless of weather conditions or material availability. Work on national holidays will not be permitted without written permission of the Engineer. If work is performed on any of these holidays requiring an Inspector to be present, and weather or other conditions permit the performance of work for 7 hr. between 7:00 A.M. and 6:00 P.M., a working day will be charged.
- 3.1.4. **Standard Workweek.** Working days will be charged Monday through Friday, excluding national or state holidays, if weather or other conditions permit the performance of the principal unit of work underway, as determined by the Engineer, for a continuous period of at least 7 hr. between 7:00 A.M. and 6:00 P.M., unless otherwise shown in the Contract. The Contractor has the option of working on Saturdays or state holidays. Provide sufficient advance notice to the Engineer when scheduling work on Saturdays. Work on Sundays and national holidays will not be permitted without written permission of the Engineer. If work requiring an Inspector to be present is performed on a Saturday, Sunday, or holiday, and weather or other conditions permit the performance of work for 7 hr. between 7:00 A.M. and 6:00 P.M., a working day will be charged.
- 3.1.5. **Calendar Day.** Working days will be charged Sunday through Saturday, including all holidays, regardless of weather conditions, material availability, or other conditions not under the control of the Contractor.
- 3.1.6. **Other.** Working days will be charged as shown on the plans.
- 3.2. **Restricted Work Hours.** Restrictions on Contractor work hours and the related definition for working day charges are as prescribed in this Article unless otherwise shown on the plans.
- 3.3. **Nighttime Work.** Nighttime work is allowed only when shown on the plans or directed or allowed by the Engineer. Nighttime work is defined as work performed from 30 min. after sunset to 30 min. before sunrise.
- 3.3.1. **Five-, Six-, and Seven-Day Workweeks.** Nighttime work that extends past midnight will be assigned to the following day for the purposes of approval for allowing work on Sundays or national holidays.
- 3.3.2. **Standard Workweek.**
- 3.3.2.1. **Nighttime Work Only.** When nighttime work is allowed or required and daytime work is not allowed, working day charges will be made when weather and other conditions permit the performance of the principal unit of work underway, as determined by the Engineer, for a continuous period of at least 7 hr. for the nighttime period, as defined in Section 8.3.3., "Nighttime Work," unless otherwise shown in the Contract.
- 3.3.2.2. **Nighttime Work and Daytime Work Requiring Inspector.** When nighttime work is performed or required and daytime work is allowed, working day charges will be made when weather and other conditions permit the performance of the principal unit of work underway, as determined by the Engineer, for a continuous period of at least 7 hr. for the nighttime period, as defined in Section 8.3.3., "Nighttime Work," or for a continuous period of at least 7 hr. for the alternative daytime period unless otherwise shown in the Contract. Only one day will be charged for each 24-hr. time period. When the Engineer agrees to restrict work hours to the nighttime period only, working day charges will be in accordance with Section 8.3.3.2.1., "Nighttime Work Only."
- 3.4. **Time Statements.** The Engineer will furnish the Contractor a monthly time statement. Review the monthly time statement for correctness. Report protests in writing, no later than 30 calendar days after receipt of the time statement, providing a detailed explanation for each day protested. Not filing a protest within 30 calendar days will indicate acceptance of the working day charges and future consideration of that statement will not be permitted.

4. TEMPORARY SUSPENSION OF WORK OR WORKING DAY CHARGES

The Engineer may suspend the work, wholly or in part, and will provide notice and reasons for the suspension in writing. Suspend and resume work only as directed in writing.

When part of the work is suspended, the Engineer may suspend working day charges only when conditions not under the control of the Contractor prohibit the performance of critical activities. When all of the work is suspended for reasons not under the control of the Contractor, the Engineer will suspend working day charges.

5. PROJECT SCHEDULES

Prepare, maintain, and submit project schedules. Project schedules are used to convey the Contractor's intended work plan to the Department. Prepare project schedules with a level of effort sufficient for the work being performed.

The work performed under this Article will not be measured or paid for directly but will be subsidiary to pertinent Items.

5.1. **Project Scheduler.** Designate an individual who will develop and maintain the progress schedule. The project scheduler will be prepared to discuss, in detail, the proposed sequence of work and methods of operation, and how that information will be communicated through the progress schedule at the preconstruction meeting. This individual will also attend the project meetings and make site visits to prepare, develop, and maintain the progress schedules.

5.2. **Progress Schedule.** Before starting work, prepare and submit a progress schedule based on the sequence of work and traffic control plan shown in the Contract. Prepare the progress schedule as a bar chart or critical path method (CPM) as shown on the plans. Include all planned work activities and sequences and show Contract completion within the number of working days specified. Incorporate major material procurements, known utility relocations, and other activities that may affect the completion of the Contract in the progress schedule. Show a beginning date, ending date, and duration in whole working days for each activity. Do not use activities exceeding 20 working days, unless agreed upon with the Engineer. Show an estimated production rate per working day for each work activity, unless agreed upon with the Engineer.

5.3. **Schedule Format.** Format all project schedules according to the following:

- begin the project schedule on the date of the start of Contract time or start of activities affecting work on the project,
- show the sequence and interdependence of activities required for complete performance of the work. If using a CPM schedule, show a predecessor and a successor for each activity, and
- ensure all work sequences are logical and show a coordinated plan of the work.

CPM schedules must also include:

- clearly and accurately identify the critical path as the longest continuous path,
- provide a legend for all abbreviations, run date, data date, project start date, and project completion date in the title block of each schedule submittal, and
- through the use of calendars, incorporate seasonal weather conditions into the schedule for work (e.g., earthwork, concrete paving, structures, asphalt, drainage, etc.) that may be influenced by temperature or precipitation. Also, incorporate non-work periods such as holidays, weekends, or other non-work days as identified in the Contract.

5.4. **Activity Format.** For each activity on the project schedule provide:

- a concise description of the work represented by the activity,
- an activity duration in whole working days, and
- code activities so that organized plots of the schedule may be produced.

CPM schedules must also include the quantity of work and estimated production rate for major items of work. Provide enough information for review of the work being performed.

5.5. **Schedule Types.**

5.5.1. **Bar Chart.** Seven calendar days before the preconstruction meeting, prepare and submit a hard copy of the schedule using the bar chart method.

5.5.1.1. **Progress Schedule Reviews.** Update the project schedule and submit a hard copy when changes to the schedule occur or when requested.

5.5.2. **Critical Path Method.** Prepare and submit the schedule using the CPM.

5.5.2.1. **Preliminary Schedule.** Seven calendar days before the preconstruction meeting, submit both the plotted and electronic copies of the project schedule showing activities beginning with the authorization date to begin work and including activities to be performed within the first 90 calendar days from the work start date.

5.5.2.2. **Baseline Schedule.** The baseline schedule will be considered the Contractor's plan to successfully construct the project within the timeframe and construction sequencing indicated in the Contract. Submit both plotted and electronic copies of the baseline schedule. Submit 2 plots of the schedule: one organized with the activities logically grouped using the activity coding; and the other plot showing only the critical path determined by the longest path, not based on critical float.

Develop and submit the baseline schedule for review within the first 45 calendar days from the work start date unless the time for submission is extended by the Engineer.

5.5.2.2.1. **Review.** Within 15 calendar days of receipt of the schedule, the Engineer will evaluate, and inform the Contractor if the schedule has been accepted. If the schedule is not accepted, the Engineer will provide comments to the Contractor for incorporation. Provide a revised schedule based on the Engineer's comments, or reasons for not doing so within 10 calendar days. The Engineer's review and acceptance of the project schedule is for conformance to the requirements of the Contract documents only and does not relieve the Contractor of any responsibility for meeting the interim milestone dates (if specified) or the Contract completion date. Review and acceptance does not expressly or by implication warrant, acknowledge, or admit the reasonableness of the logic or durations of the project schedule. If the Contractor fails to define any element of work, activity, or logic and the Engineer's review does not detect this omission or error, the Contractor is responsible for correcting the error or omission.

Submit an acceptable baseline schedule before the 90th calendar day from the work start date unless the time for submission is extended by the Engineer.

5.5.2.3. **Progress Schedule.** Maintain and submit the project schedule monthly for use by both the Contractor and the Engineer. Submit both the plotted and electronic copy as it will become an as-built record of the daily progress achieved on the project. If continuous progress of an activity is interrupted for any reason except non-work periods (such as holidays, weekend, or interference from temperature or precipitation), then the activity will show the actual finish date as that date of the start of the interruption and the activity will be broken into a subsequent activity (or activities, based on the number of interruptions) similarly numbered with successive alpha character as necessary. The original duration of the subsequent activity will be that of the remaining duration of the original activity. Relationships of the subsequent activity will match those of the original activity so that the integrity of the project schedule logic is maintained. Once established, the original durations and actual dates of all activities must remain unchanged. Revisions to the schedule may be made as necessary.

The project schedule must be revised when changes in construction phasing and sequencing occur or other changes that cause deviation from the original project schedule occur. Any revisions to the schedule must be listed in the monthly update narrative with the purpose of the revision and description of the impact on the project schedule's critical path and project completion date. Create the schedule revision using the latest update before the start of the revision.

Monthly updating of the project schedule will include updating of:

- the actual start dates for activities started,
- the actual finish dates for activities completed,
- the percentage of work completed and remaining duration for each activity started but not yet completed, and
- the calendars to show days actual work was performed on the various work activities.

The cut-off day for recording monthly progress will be the last day of each month. Submit the updated project schedule no later than the 20th calendar day of the following month. The Engineer will evaluate the updated schedule within 5 calendar days of receipt and inform the Contractor if it has or has not been accepted. If the schedule is not accepted, the Engineer will provide comments to the Contractor for incorporation. Provide a revised schedule based on the Engineer's comments, or reasons for not doing so within 5 calendar days.

Provide a brief narrative in a bulleted statement format for major items that have impacted the schedule. Notify the Engineer if resource-leveling is being used.

5.5.2.3.1. **Project Schedule Summary Report (PSSR).** When shown on the plans, provide the PSSR instead of the narrative required in Section 8.5.5.2.3., "Progress Schedule." The PSSR includes a listing of major items that have impacted the schedule as well as a summary of progress in days ahead or behind schedule. Include an explanation of the project progress for the period represented on the form provided by the Department.

5.5.3. **Notice of Potential Time Impact.** Submit a notice of potential time impact when a Contract time extension or adjustment of milestone dates may be justified or when directed.

Failure to provide this notice in the timeframes outlined above will compromise the Department's ability to mitigate the impacts and the Contractor forfeits the right to request a time extension or adjustment of milestone dates unless the circumstances are such that the Contractor could not reasonably have had knowledge of the impact at the time.

5.5.4. **Time Impact Analysis.** When directed, provide a time impact analysis. A time impact analysis is an evaluation of the effects of impacts on the project. A time impact analysis consists of the following steps:

- **Step 1.** Establish the status of the project immediately before the impact.
- **Step 2.** Predict the effect of the impact on the schedule update used in Step 1.
- **Step 3.** Track the effects of the impact on the schedule during its occurrence.
- **Step 4.** Establish the status of the project after the impact's effect has ended and provide details identifying any mitigating actions or circumstances used to keep the project ongoing during the impact period.

Determine the time impact by comparing the status of the work before the impact (Step 1) to the prediction of the effect of the impact (Step 2), if requested, and to actual effects of the impact once it is complete (Step 4). Unless otherwise approved by the Engineer, steps 1, 3, and 4, must be completed before consideration of a Contract time extension or adjustment of a milestone date will be provided. Time extensions will only be considered when delays that affect milestone dates or the Contract completion date are beyond the Contractor's control. Submit Step 4 no later than 15 calendar days after the impact's effects have ended or when all the information on the effect has been realized.

Submit one electronic backup copy of the complete time impact analysis and a copy of the full project schedule incorporating the time impact analysis. If the project schedule is revised after the submittal of a time impact analysis, but before its approval, indicate in writing the need for any modification to the time impact analysis.

The Engineer will review the time impact analysis upon completion of step 4. If this review detects revisions or changes to the schedule that had not been performed and identified in a narrative, the Engineer may reject the time impact analysis. If the Engineer is in agreement with the time impact analysis, a change order may be issued to grant additional working days, or to adjust interim milestones. Once a change order has been executed, incorporate the time impact analysis into the project schedule. The time impact analysis may

also be used to support the settlement of disputes and claims. Compensation related to the time impact analysis may be provided at the completion of the analysis or the completion of the project to determine the true role the impact played on the final completion.

6. FAILURE TO COMPLETE WORK ON TIME

The time established for the completion of the work is an essential element of the Contract. If the Contractor fails to complete the work within the number of working days specified, working days will continue to be charged. Failure to complete the Contract, callout work, or a work order within the number of working days specified, including any approved additional working days, will result in liquidated damages for each working day charged over the number of working days specified. The dollar amount specified in the Contract will be deducted from any money due or to become due the Contractor for each working day the Contract, callout work, or work order remains incomplete. This amount will be assessed not as a penalty but as liquidated damages. The amount assessed for non-site-specific Contracts will be based on the estimated amount for each work order unless otherwise shown in the Contract. The amount assessed for each callout will be as specified in the Contract.

7. DEFAULT OF CONTRACT

7.1. **Declaration of Default.** The Engineer may declare the Contractor to be in default of the Contract if the Contractor:

- fails to begin the work within the number of days specified;
- fails to prosecute the work to assure completion within the number of days specified;
- is uncooperative, disruptive or threatening;
- fails to perform the work in accordance with the Contract requirements;
- neglects or refuses to remove and replace rejected materials or unacceptable work;
- discontinues the prosecution of the work without the Engineer's approval;
- makes an unauthorized assignment;
- fails to resume work that has been discontinued within a reasonable number of days after notice to do so;
- fails to conduct the work in an acceptable manner; or
- commits fraud or other unfixable conduct as determined by the Department.

If any of these conditions occur, the Engineer will give notice in writing to the Contractor and the Surety of the intent to declare the Contractor in default. If the Contractor does not proceed as directed within 10 days after the notice, the Department will provide written notice to the Contractor and the Surety to declare the Contractor to be in default of the Contract. If the Contractor provides the Department written notice of voluntary default of the Contract, the Department may waive the 10 day notice of intent to declare the Contractor in default and immediately provide written notice of default to the Contractor and the Surety. Working day charges will continue until completion of the Contract. The Department may suspend work in accordance with Section 8.4., "Temporary Suspension of Work or Working Day Charges," to investigate apparent fraud or other unfixable conduct before defaulting the Contractor. The Contractor may be subject to sanctions under the TAC.

The Department will determine the method used for the completion of the remaining work as follows:

- For Contracts without performance bonds, the Department will determine the most expeditious and efficient way to complete the work, and recover damages from the Contractor.
- For Contracts with performance bonds, the Department will require the Contractor's Surety to complete the remaining work in accordance with the terms of the original Contract. A completing Contractor will be considered a subcontractor of the Surety. The Department reserves the right to approve or reject proposed subcontractors. Work may resume after the Department receives and approves Certificates of Insurance as required in Section 3.4.3., "Insurance." Certificates of Insurance may be issued in the name of the completing Contractor. The Surety is responsible for making every effort to expedite the

resumption of work and completion of the Contract. The Department may complete the work using any or all materials at the work locations that it deems suitable and acceptable. Any costs incurred by the Department for the completion of the work under the Contract will be the responsibility of the Surety.

From the time of notification of the default until work resumes (either by the Surety or the Department), the Department will maintain traffic control devices and will do any other work it deems necessary, unless otherwise agreed upon by the Department and the Surety. All costs associated with this work will be deducted from money due to the Surety.

The Department will hold all money earned but not disbursed by the date of default. Upon resumption of the work after the default, all payments will be made to the Surety. All costs and charges incurred by the Department as a result of the default, including the cost of completing the work under the Contract, costs of maintaining traffic control devices, costs for other work deemed necessary, and any applicable liquidated damages or disincentives will be deducted from money due the Contractor for completed work. If these costs exceed the sum that would have been payable under the Contract, the Surety will be liable and pay the Department the balance of these costs in excess of the Contract price. In case the costs incurred by the Department are less than the amount that would have been payable under the Contract if the work had been completed by the Contractor, the Department will be entitled to retain the difference.

Comply with Article 8.2, "Subcontracting," and abide by the DBE commitments previously approved by the Department. Section 8.2.1., "Construction Contracts and Federally Funded Maintenance Contracts," is waived.

No markups as defined in Article 9.7., "Payment for Extra Work and Force Account Method," will be allowed for the Surety.

- 7.2. **Wrongful Default.** For consideration of wrong default, submit a written request to the Construction Division within 30 calendar days of receipt of notice of default.

The Construction Division will determine if the Contractor has been wrongfully defaulted and will proceed with one of the following actions:

- In the event that the Construction Division determines the default is proper, the default will remain in accordance with Section 8.7.1., "Declaration of Default." If the Contractor is in disagreement, the Contractor may file a claim in accordance with Article 4.7., "Dispute or Claims Procedure."
- In the event that the Construction Division determines it was a wrongful default, the Construction Division will terminate the Contract in the best interest of the State or the public in accordance with Article 8.8., "Termination of Contract."

8. TERMINATION OF CONTRACT

The Department may terminate the Contract in whole or in part whenever:

- the Contractor is prevented from proceeding with the work as a direct result of an executive order of the President of the United States or the Governor of the State,
- the Contractor is prevented from proceeding with the work due to a national emergency, or when the work to be performed under the Contract is stopped, directly or indirectly, because of the freezing or diversion of materials, equipment or labor as the result of an order or a proclamation of the President of the United States,
- the Contractor is prevented from proceeding with the work due to an order of any federal authority,
- the Contractor is prevented from proceeding with the work by reason of a preliminary, special, or permanent restraining court order where the issuance of the restraining order is primarily caused by acts or omissions of persons or agencies other than the Contractor, or
- the Department determines that termination of the Contract is in the best interest of the State or the public. This includes but is not limited to the discovery of significant hazardous material problems, right

of way acquisition problems, or utility conflicts that would cause substantial delays or expense to the Contract.

- 8.1. **Procedures and Submittals.** The Department will provide written notice to the Contractor of termination specifying the extent of the termination and the effective date. Upon notice, immediately proceed in accordance with the following:
- stop work as specified in the notice,
 - place no further subcontracts or orders for materials, services, or facilities, except as necessary to complete a critical portion of the Contract, as approved by the Engineer,
 - terminate all subcontracts to the extent they relate to the work terminated,
 - complete performance of the work not terminated,
 - settle all outstanding liabilities and termination settlement proposals resulting from the termination of the Contract,
 - create an inventory report, including all acceptable materials and products obtained for the Contract that have not been incorporated in the work that was terminated (include in the inventory report a description, quantity, location, source, cost, and payment status for each of the acceptable materials and products), and
 - take any action necessary, or that the Engineer may direct, for the protection and preservation of the materials and products related to the Contract that are in the possession of the Contractor and in which the Department has or may acquire an interest.
- 8.2. **Settlement Provisions.** Within 60 calendar days of the date of the notice of termination, submit a final termination settlement proposal, unless otherwise approved. The Engineer will prepare a change order that reduces the affected quantities of work and adds acceptable costs for termination. No claim for loss of anticipated profits will be considered. The Department will pay reasonable and verifiable termination costs including:
- all work completed at the unit bid price and partial payment for incomplete work,
 - the percentage of Item 500, "Mobilization," equivalent to the percentage of work complete or actual cost that can be supported by cost records, whichever is greater,
 - expenses necessary for the preparation of termination settlement proposals and support data;
 - the termination and settlement of subcontracts,
 - storage, transportation, restocking, and other costs incurred necessary for the preservation, protection, or disposition of the termination inventory, and
 - other expenses acceptable to the Department.

Item 9

Measurement and Payment



1. MEASUREMENT OF QUANTITIES

The Engineer will measure all completed work using United States standard measures, unless otherwise specified.

- 1.1. **Linear Measurement.** Unless otherwise specified, all longitudinal measurements for surface areas will be made along the actual surface of the roadway and not horizontally. No deduction will be made for structures in the roadway having an area of 9 sq. ft. or less. For all transverse measurements for areas of base courses, surface courses, and pavements, the dimensions to be used in calculating the pay areas will be the neat dimensions and will not exceed those shown on the plans, unless otherwise directed.

- 1.2. **Volume Measurement.** Transport materials measured for payment by volume in approved hauling vehicles. Display a unique identification mark on each vehicle. Furnish information necessary to calculate the volume capacity of each vehicle. The Engineer may require verification of volume through weight measurement. Use body shapes that allow the capacity to be verified. Load and level the load to the equipment's approved capacity. Loads not hauled in approved vehicles may be rejected.

- 1.3. **Weight Measurement.** Transport materials measured for payment by weight or truck measure in approved hauling vehicles. Furnish certified measurements, tare weights, and legal gross weight calculations for all haul units. Affix a permanent, legible number on the truck and on the trailer to correspond with the certified information. Furnish certified weights of loaded haul units transporting material if requested.

The material will be measured at the point of delivery. The cost of supplying these volume and weight capacities is subsidiary to the pertinent Item. For measurement by the ton, in the field, provide measurements in accordance with Item 520, "Weighing and Measuring Equipment," except for Items where ton measurements are measured by standard tables.

The Engineer may reject loads and suspend hauling operations for overloading.

- 1.3.1. **Hauling on Routes Accessible to the Traveling Public.** For payment purposes on haul routes accessible to the traveling public, the net weight of the load will be calculated as follows:
- If the gross vehicle weight is less than the maximum allowed by state law, including applicable yearly weight tolerance permit, the net weight of the load will be determined by deducting the tare weight of the vehicle from the gross weight.
 - If the gross vehicle weight is more than the maximum allowed by state law, including applicable yearly weight tolerance permit, the net weight of the load will be determined by deducting the tare weight of the vehicle from the maximum gross weight allowed.
- 1.3.2. **Hauling on Routes Not Accessible to the Traveling Public.** For payment purposes on haul routes that are not accessible to the traveling public where advance permission is obtained in writing from the Engineer.
- If the gross vehicle weight is less than the maximum allowed by the Engineer, including applicable yearly weight tolerance permit, the net weight of the load will be determined by deducting the tare weight of the vehicle from the gross weight.
 - If the gross vehicle weight is more than the maximum allowed by the Engineer, the net weight of the load will be determined by deducting the tare weight of the vehicle from the maximum gross weight allowed.

2. PLANS QUANTITY MEASUREMENT

Plans quantities may or may not represent the exact quantity of work performed or material moved, handled, or placed during the execution of the Contract. The estimated bid quantities are designated as final payment quantities, unless revised by the governing specifications or this Article.

If the quantity measured as outlined under "Measurement" varies by more than 5% (or as stipulated under "Measurement" for specific Items) from the total estimated quantity for an individual Item originally shown in the Contract, an adjustment may be made to the quantity of authorized work done for payment purposes.

When quantities are revised by a change in design approved by the Department, by change order, or to correct an error on the plans, the plans quantity will be increased or decreased by the amount involved in the change, and the 5% variance will apply to the new plans quantity.

If the total Contract quantity multiplied by the unit bid price for an individual Item is less than \$250 and the Item is not originally a plans quantity Item, then the Item may be paid as a plans quantity Item if the Engineer and Contractor agree in writing to fix the final quantity as a plans quantity.

For Contracts with callout work and work orders, plans quantity measurement requirements are not applicable.

3. ADJUSTMENT OF QUANTITIES

The party to the Contract requesting the adjustment will provide field measurements and calculations showing the revised quantity. When approved, this revised quantity will constitute the final quantity for which payment will be made. Payment for revised quantity will be made at the unit price bid for that Item, except as provided for in Article 4.4., "Changes in the Work."

4. SCOPE OF PAYMENT

Payment of the Contract unit price is full compensation for all materials, equipment, labor, tools, and supplies necessary to complete the Item of work under the Contract. Until final acceptance in accordance with Article 5.12., "Final Acceptance," assume liability for completing the work according to the plans and specifications and any loss or damage arising from the performance of the work or from the action of the elements, infringement of patent, trademark, or copyright, except as provided elsewhere in the Contract.

The Department will only pay for material incorporated into the work in accordance with the Contract. Payment of progress estimates will in no way affect the Contractor's obligation under the Contract to repair or replace any defective parts in the construction or to replace any defective materials used in the construction and to be responsible for all damages due to defects if the defects and damages are discovered on or before final inspection and acceptance of the work.

5. PROGRESS PAYMENTS

The Engineer will prepare a monthly estimate of the amount of work performed, including materials in place. Incomplete items of work may be paid at an agreed upon percentage approved by the Engineer. Payment of the monthly estimate is determined at the Contract item prices less any withholdings or deductions in accordance with the Contract. Progress payments may be withheld for failure to comply with the Contract.

6. PAYMENT FOR MATERIAL ON HAND (MOH)

If payment for MOH is desired, request compensation for the invoice cost of acceptable nonperishable materials that have not been used in the work before the request, and that have been delivered to the work location or are in acceptable storage places. Nonperishable materials are those that do not have a shelf life or whose characteristics do not materially change when exposed to the elements. Include only materials that

have been sampled, tested, approved, or certified, and are ready for incorporation into the work. Only materials which are completely constructed or fabricated on the Contractor's order for a specific Contract and are so marked and on which an approved test report has been issued are eligible. Payment for MOH may include the following types of items: concrete traffic barrier, precast concrete box culverts, concrete piling, reinforced concrete pipe, and illumination poles. Any repairs required after fabricated materials have been approved for storage will require approval of the Engineer before being made and will be made at the Contractor's expense. Include only those materials that have an invoice cost of at least \$1,000 in the request for MOH payment.

For Contracts with callout work and work orders, payment for MOH will only be made for materials authorized for purchase by the work order or by written approval of the Engineer.

If the request is acceptable, the Engineer will include payment for MOH in a progress payment. Payment for MOH does not constitute acceptance of the materials. Payment will not exceed the actual cost of the material as established by invoice, or the total cost for the associated item less reasonable placement costs, whichever is less. Materials for which the Contractor does not have a paid invoice within 60 days will not be eligible for payment and will be removed from the estimate. Payment may be limited to a portion of the invoice cost or unit price if shown elsewhere in the Contract. Payment for precast products fabricated or constructed by the Contractor for which invoices or freight bills are not available may be made based on statements of actual cost.

Submit the request on forms provided by the Department. These forms may be electronically reproduced, provided they are in the same format and contain all the required information and certifications. Continue to submit monthly MOH forms until the total value of MOH is \$0.

By submitting a request for MOH payment, the Contractor expressly authorizes the Department to audit MOH records, and to perform process reviews of the record-keeping system. If the Department determines noncompliance with any of the requirements of this provision, the Department may exclude payment for any or all MOH for the duration of the Contract.

Maintain all records relating to MOH payment until final acceptance. Provide these records to the Engineer upon request.

7. PAYMENT FOR EXTRA WORK AND FORCE ACCOUNT METHOD

Payment for extra work directed, performed, and accepted will be made in accordance with Article 4.4., "Changes in the Work." Payment for extra work may be established by agreed unit prices or by Force Account Method.

Agreed unit prices are unit prices that include markups and are comparable to recent bid prices for the same character of work. These unit prices may be established without additional breakdown justification.

When using Force Account Method, determine an estimated cost for the proposed work and establish labor and equipment rates and material costs. Maintain daily records of extra work and provide copies of these records daily, signed by the Contractor's representative, for verification by the Department. Request payment for the extra work no later than the 10th day of the month following the month in which the work was performed. Include copies of all applicable invoices. If the extra work to be performed has an estimated cost of less than \$10,000, submit for approval and payment an invoice of actual cost for materials, equipment, labor, tools, and incidentals necessary to complete the extra work.

7.1. **Markups.** Payment for extra work may include markups as compensation for the use of small tools, overhead expense, and profit.

7.1.1. **Labor.** Compensation will be made for payroll rates for each hour that the labor and foremen or others approved by the Engineer are actually engaged in the work. In no case will the rate of wages be less than the

minimum shown in the Contract for a particular category. An additional 25% of this sum will be paid as compensation for overhead, superintendence, profit, and small tools.

7.1.2. **Insurance and Taxes.** An additional 55% of the labor cost, excluding the 25% compensation provided in Section 9.7.1.1., "Labor," will be paid as compensation for labor insurance and labor taxes including the cost of premiums on non-project specific liability (excluding vehicular) insurance, workers compensation insurance, Social Security, unemployment insurance taxes, and fringe benefits.

7.1.3. **Materials.** Compensation will be made for materials associated with the work based on actual delivered invoice costs, less any discount. An additional 25% of this sum will be paid as compensation for overhead and profit.

7.1.4. **Equipment.** Payment will be made for the established equipment hourly rates for each hour that the equipment is involved in the work. An additional 15% of this sum will be paid as compensation for overhead and profit not included in the rates.

Transportation cost for mobilizing equipment will be included if the equipment is mobilized from an off-site location.

7.1.4.1. **Contractor-Owned Equipment.** For Contractor-owned machinery, trucks, power tools, or other equipment, use the FHWA rental rates found in the *Rental Rate Blue Book* multiplied by the regional adjustment factor and the rate adjustment factor to establish hourly rates. Use the rates in effect for each section of the *Rental Rate Blue Book* at the time of use.

If a rate has not been established for a particular piece of equipment in the *Rental Rate Blue Book*, the Engineer will allow a reasonable hourly rate. This price will include operating costs.

Payment for equipment will be made for the actual hours used in the work. The Department reserves the right to withhold payment for low production or lack of progress. Payment will not be made for time lost for equipment breakdowns, time spent to repair equipment, or time after equipment is no longer needed.

If equipment is used intermittently while dedicated solely to the work, payment will be made for the duration the equipment is assigned to the work but no more than 8 hr. will be paid during a 24-hr. day, nor more than 40 hr. per week, nor more than 176 hr. per month, except when time is computed using a 6-day or 7-day workweek. When using a 6-day workweek, no more than 8 hr. will be paid during a 24-hr. day, nor more than 48 hr. per week, nor more than 211 hr. per month. When using a 7-day workweek, no more than 8 hr. will be paid during a 24-hr. day, nor more than 56 hr. per week, nor more than 246 hr. per month.

7.1.4.2. **Equipment Not Owned by the Contractor.** For equipment rented from a third party not owned by the Contractor, payment will be made at the invoice daily rental rate for each day the equipment is needed for the work. The Department reserves the right to limit the daily rate to comparable FHWA rental rates found in the *Rental Rate Blue Book* multiplied by the regional adjustment factor and the rate adjustment factor. When the invoice specifies that the rental rate does not include fuel, lubricants, repairs, and servicing, the *Rental Rate Blue Book* hourly operating cost for each hour the equipment is operated will be added.

When the invoice specifies equipment operators as a component of the equipment rental, payment will be made at the invoice rate for each operator for each day the equipment is needed for the work.

7.1.4.3. **Standby Equipment Costs.** Payment for standby equipment will be made in accordance with Section 9.7.1.4., "Equipment," except that:

7.1.4.3.1. **Contractor-Owned Equipment.** For Contractor-owned machinery, trucks, power tools, or other equipment:

- Standby will be paid at 50% (to remove operating cost) of the FHWA rental rates found in the *Rental Rate Blue Book* multiplied by the regional adjustment factor and the rate adjustment factor.
- Standby costs will not be allowed during periods when the equipment would have otherwise been idle.

- 7.1.4.3.2. **Equipment Not Owned by the Contractor.** For equipment rented from a third party not owned by the Contractor:
- Standby will be paid at the invoice daily rental rate, excluding operating cost, which includes fuel, lubricants, repairs, and servicing. The Department reserves the right to limit the daily standby rate to comparable FHWA rental rates found in the *Rental Rate Blue Book* multiplied by the regional adjustment factor and the rate adjustment factor.
 - Standby will be paid for equipment operators when included on the invoice and equipment operators are actually on standby.
 - Standby costs will not be allowed during periods when the equipment would have otherwise been idle.
- 7.1.5. **Subcontracting.** An additional 5% of the actual invoice cost will be paid to the Contractor as compensation for administrative cost, superintendence, and profit.
- 7.1.6. **Law Enforcement Personnel.** An additional 5% of the actual invoice cost will be paid as compensation for administrative costs, superintendence, and profit.
- 7.1.7. **Railroad Flaggers.** An additional 5% of the actual invoice cost will be paid as compensation for administrative cost, superintendence, and profit.
- 7.1.8. **Bond Cost.** An additional 1% of the total compensation provided in Article 9.7., "Payment for Extra Work and Force Account Method," will be paid for the increase in bond.

8. RETAINAGE

The Department will not withhold retainage on the Contractor. The Contractor may withhold retainage on subcontractors in accordance with state and federal regulations.

9. PAYMENT PROVISIONS FOR SUBCONTRACTORS

For the purposes of this Article only, the term subcontractor includes suppliers and the term work includes materials provided by suppliers at a location approved by the Department.

These requirements apply to all tiers of subcontractors. Incorporate the provisions of this Article into all subcontract or material purchase agreements.

Pay subcontractors for work performed within 10 days after receiving payment from the Department.

Pay any retainage on a subcontractor's work within 10 days after satisfactory completion of all of the subcontractor's work. Completed subcontractor work includes vegetative establishment, test, maintenance, performance, and other similar periods that are the responsibility of the subcontractor.

For the purpose of this Section, satisfactory completion is accomplished when:

- the subcontractor has fulfilled the Contract requirements of both the Department and the subcontract for the subcontracted work, including the submittal of all information required by the Contract and the Department, and
- the work done by the subcontractor has been inspected, approved, and paid by the Department.

Provide a certification of prompt payment to certify that all subcontractors and suppliers were paid from the previous months payments and retainage was released for those whose work is complete. Submit the certification in the manner prescribed by the Department each month and the month following the month when final acceptance occurred.

The inspection and approval of a subcontractor's work does not eliminate the Contractor's responsibilities for the work as defined in Article 7.17., "Contractor's Responsibility for Work."

10. FINAL PAYMENT

When the Contract has been completed, all work has been approved, final acceptance has been made in accordance with Article 5.12., "Final Acceptance," and Contractor submittals have been received, the Engineer will prepare a final estimate for payment showing the total quantity of work completed and the money owed the Contractor. The final payment will reflect the entire sum due, less any sums previously paid.

100 Items

Earthwork and Landscape

This page intentionally left blank

Item 100

Preparing Right of Way



1. DESCRIPTION

Prepare the right of way and designated easements for construction operations by removing and disposing of all obstructions when removal of such obstructions is not specifically shown on the plans to be paid by other Items.

2. CONSTRUCTION

Protect designated features on the right of way and prune trees and shrubs as directed. Do not park equipment, service equipment, store materials, or disturb the root area under the branches of trees designated for preservation. Treat cuts on trees with an approved tree wound dressing within 20 min. of making a pruning cut or otherwise causing damage to the tree when shown on the plans. Follow all local and state regulations when burning. Pile and burn brush at approved locations as directed. Coordinate work with state and federal authorities when working in state or national forests or parks. Test, remove, and dispose of hazardous materials in accordance with Article 6.10., "Hazardous Materials."

Clear areas shown on the plans of all obstructions, except those landscape features that are to be preserved. Such obstructions include remains of houses and other structures, foundations, floor slabs, concrete, brick, lumber, plaster, septic tank drain fields, basements, abandoned utility pipes or conduits, equipment, fences, retaining walls, and other items as specified on the plans. Remove vegetation and other landscape features not designated for preservation, curb and gutter, driveways, paved parking areas, miscellaneous stone, sidewalks, drainage structures, manholes, inlets, abandoned railroad tracks, scrap iron, and debris, whether above or below ground. Removal of live utility facilities is not included in this Item. Remove culverts, storm sewers, manholes, and inlets in proper sequence to maintain traffic and drainage.

Notify the Engineer in writing when items not shown on the plans and not reasonably detectable (buried with no obvious indication of presence) are encountered and required to be removed. These items will be handled in accordance with Article 4.5., "Differing Site Conditions."

Remove obstructions not designated for preservation to 2 ft. below natural ground in areas receiving embankment. Remove obstructions to 2 ft. below the excavation level in areas to be excavated. Remove obstructions to 1 ft. below natural ground in all other areas. Cut trees and stumps off to ground level when allowed by the plans or directed. Plug the remaining ends of abandoned underground structures over 3 in. in diameter with concrete to form a tight closure. Backfill, compact, and restore areas where obstructions have been removed unless otherwise directed. Use approved material for backfilling. Dispose of wells in accordance with Item 103, "Disposal of Wells."

Accept ownership, unless otherwise directed, and dispose of removed materials and debris at locations off the right of way in accordance with local, state, and federal requirements.

3. MEASUREMENT

This Item will be measured by the acre; by the 100-ft. station, regardless of the width of the right of way; or by each tree removed.

4. PAYMENT

For "acre" and "station" measurement, the work performed in accordance with this Item and measured as provided under "Measurement" will be paid for at the unit price bid for "Preparing Right of Way." For "each"

measurement, the work performed in accordance with this Item and measured as provided under "Measurement" will be paid for at the unit price bid for "Preparing Right of Way (Tree)" of the diameter specified. This price is full compensation for pruning of designated trees and shrubs; removal and disposal of structures and obstructions; backfilling of holes; furnishing and placing concrete for plugs; and equipment, labor, tools, and incidentals.

Total payment of this Item will not exceed 10% of the original contract amount until final acceptance. The remainder will be paid on the estimate after the final acceptance under Article 5.12., "Final Acceptance."

Item 103

Disposal of Wells



1. DESCRIPTION

Remove and dispose of contaminated and uncontaminated water, petroleum, or sulfur wells. Remove appurtenances, seal and plug wells, and restore the area. Prepare and file required documents with applicable agencies.

2. CONSTRUCTION

Follow legal responsibilities, construction requirements, and methods in accordance with Article 7.3., "Laws to be Observed," and Article 7.4., "Permits, Licenses, and Taxes."

Remove all pump equipment to 3 ft. below the finished subgrade or the existing grade, whichever is lower, and within construction limits. Pump equipment includes pump, piping, motor, housing, well structures, foundations, flumes, windmills, casing, and other projecting objects associated with the well.

All removed items and appurtenances become the property of the Contractor, excluding existing contaminated soil and liquids, after necessary cleaning and disassembling. Dispose of these items in accordance with applicable laws and regulations. Test, remove, and dispose of hazardous materials in accordance with Article 6.10., "Hazardous Materials."

Cap remaining pipe. Submit a "Plugging Report" to the appropriate agency when required by the TCEQ, the TDLR, or the RRC. Furnish a copy to the Engineer. Backfill in accordance with Article 100.2., "Construction," after removing all appurtenances.

- 2.1. **Water Wells.** Remove all removable casing from water wells, including dry wells and abandoned wells. Pressure-fill the well with a mixture of hydraulic cement and water at a rate of not more than 7 gal. of water per sack of cement from the bottom of the well to the natural ground surface or 3 ft. below the finished subgrade, whichever is lower, according to the requirements of the TDLR. Obtain written approval from TDLR and the Engineer for alternative procedures.

Plug any well located in a cut section up to the proposed earthwork elevation before excavating the cut. Backfill the remainder of the well above the proposed earthwork elevation with earth immediately after plugging a well in a cut section.

- 2.2. **Petroleum and Sulfur Wells.** Have a contractor from the RRC-approved list plug the well. Empty the contents of petroleum or sulfur wells into approved containers according to applicable regulations. Transport and dispose of the filled containers at an approved disposal facility or recycling center according to applicable regulations. Approved plugging methods include protecting water-bearing strata with cement plugs when shown on the plans, or completely cementing the well.

3. MEASUREMENT

This Item will be measured by each properly plugged and disposed well.

4. PAYMENT

The work performed and materials furnished in accordance with this Item and measured as provided under "Measurement" will be paid for at the unit price bid for "Disposal of Water Wells" or "Disposal of Petroleum or

Sulfur Wells.” This price is full compensation for removing and disposing of appurtenances; plugging; furnishing records; furnishing and placing any material or items; site restoration; and equipment, labor, tools, and incidentals.

Item 104

Removing Concrete



1. DESCRIPTION

Break, remove, and salvage or dispose of existing hydraulic cement concrete.

2. CONSTRUCTION

Remove existing hydraulic cement concrete from locations shown on the plans. Avoid damaging concrete that will remain in place. Saw-cut and remove the existing concrete to neat lines. Replace any concrete damaged by the Contractor at no expense to the Department. Accept ownership and properly dispose of broken concrete in accordance with federal, state, and local regulations unless otherwise shown on the plans.

3. MEASUREMENT

Removing concrete pavement, floors, porches, patios, riprap, medians, foundations, sidewalks, driveways, and other appurtenances will be measured by the square yard (regardless of thickness) or by the cubic yard of calculated volume, in its original position.

Removing curb, curb and gutter, and concrete traffic barrier will be measured by the foot in its original position. The removal of monolithic concrete curb or doweled concrete curb will be included in the concrete pavement measurement.

Removing retaining walls will be measured by the square yard along the front face from the top of the wall to the top of the footing.

This is a plans quantity measurement item. The quantity to be paid is the quantity shown in the proposal, unless modified by Article 9.2., "Plans Quantity Measurement." Additional measurements or calculations will be made if adjustments of quantities are required.

4. PAYMENT

The work performed and materials furnished in accordance with this item and measured as provided under "Measurement" will be paid for at the unit price bid for "Removing Concrete" of the type specified. This price is full compensation for breaking the concrete; loading, hauling, and salvaging or disposing of the material; and equipment, labor, tools, and incidentals.

Removing retaining wall footings will not be paid for directly but will be considered subsidiary to this item.

Item 105

Removing Treated and Untreated Base and Asphalt Pavement



1. DESCRIPTION

Break, remove, and store or dispose of existing asphalt pavement, including surface treatments, and treated or untreated base materials.

2. CONSTRUCTION

Break material retained by the Department into pieces not larger than 24 in. unless otherwise shown on the plans. Remove existing asphalt pavement before disturbing stabilized base. Avoid contamination of the asphalt materials and damage to adjacent areas. Repair material damaged by operations outside the designated locations.

Stockpile materials designated salvageable at designated sites when shown on the plans or as directed. Prepare stockpile site by removing vegetation and trash and by providing for proper drainage. Material not designated to be salvaged will become the property of the Contractor. When this material is disposed of, do so in accordance with federal, state, and local regulations.

3. MEASUREMENT

This Item will be measured by the 100-ft. station along the baseline of each roadbed, by the square yard of existing treated or untreated base and asphalt pavement in its original position, or by the cubic yard of existing treated or untreated base and asphalt pavement in its original position, as calculated by the average end area method. Square yard and cubic yard measurement will be established by the widths and depths shown on the plans and the lengths measured in the field.

4. PAYMENT

The work performed in accordance with this Item and measured as provided under "Measurement" will be paid for at the unit price bid for "Removing Treated and Untreated Base and Asphalt Pavement" of the depth specified. This price is full compensation for breaking the material, loading, hauling, unloading, stockpiling or disposing; repair to areas outside designated locations for removal; and equipment, labor, tools, and incidentals.

Item 106

Obliterating Abandoned Road



1. DESCRIPTION

Obliterate designated sections of abandoned road.

2. CONSTRUCTION

Strip and windrow existing topsoil before shaping operations. Remove asphaltic pavement in accordance with applicable Item. Remove material designated as salvageable in accordance with applicable Items. Remove abandoned structures unless otherwise shown on the plans. Scarify and mix the abandoned roadbed with soil and blade to produce a smooth, uniform appearance. Fill, cut, and shape the designated sections of the abandoned road to blend into the surrounding terrain. Eliminate ditches except where needed to facilitate drainage. Cover disturbed areas with topsoil after shaping operations to facilitate establishment of vegetation.

3. MEASUREMENT

This Item will be measured by the 100-ft. station along the baseline of the abandoned roadway.

4. PAYMENT

The work performed in accordance with this Item and measured as provided under "Measurement" will be paid for at the unit price bid for "Obliterating Abandoned Road." This price is full compensation for salvaging and replacing topsoil; stockpiling or disposal of materials; removal of abandoned structures; scarifying, mixing, and shaping abandoned road; furnishing and operating equipment, and labor, tools, and incidentals.

Item 110

Excavation



1. DESCRIPTION

Excavate areas as shown on the plans or as directed. Remove materials encountered to the lines, grades, and typical sections shown on the plans and cross-sections.

2. CONSTRUCTION

Accept ownership of unsuitable or excess material and dispose of material in accordance with local, state, and federal regulations at locations outside the right of way.

Maintain drainage in the excavated area to avoid damage to the roadway section. Correct any damage to the subgrade caused by weather at no additional cost to the Department.

Shape slopes to avoid loosening material below or outside the proposed grades. Remove and dispose of slides as directed.

2.1. **Rock Cuts.** Excavate to finish subgrade. Manipulate and compact subgrade in accordance with Section 132.3.4., "Compaction Methods," unless excavation is to clean homogenous rock at finish subgrade elevation. Use approved embankment material compacted in accordance with Section 132.3.4., "Compaction Methods," to replace undercut material at no additional cost if excavation extends below finish subgrade.

2.2. **Earth Cuts.** Excavate to finish subgrade. Scarify subgrade to a uniform depth at least 6 in. below finish subgrade elevation in areas where base or pavement structure will be placed on subgrade. Manipulate and compact subgrade in accordance with Section 132.3.4., "Compaction Methods."

Take corrective measures as directed if unsuitable material is encountered below subgrade elevations.

2.3. **Subgrade Tolerances.** Excavate to within 1/2 in. in cross-section and 1/2 in. in 16 ft. measured longitudinally for turnkey construction. Excavate to within 0.1 ft. in cross-section and 0.1 ft. in 16 ft. measured longitudinally for staged construction.

3. MEASUREMENT

This Item will be measured by the cubic yard in its original position as computed by the method of average end areas.

This is a plans quantity measurement Item. The quantity to be paid is the quantity shown in the proposal unless modified by Article 9.2., "Plans Quantity Measurement." Additional measurements or calculations will be made if adjustments of quantities are required.

Limits of measurement for excavation in retaining wall areas will be as shown on the plans.

Shrinkage or swelling factors will not be considered in determining the calculated quantities.

4. PAYMENT

The work performed and materials furnished in accordance with this Item and measured as provided under "Measurement" will be paid for at the unit price bid for "Excavation (Roadway)," "Excavation (Channel),"

"Excavation (Special)," or "Excavation (Roadway and Channel)." This price is full compensation for authorized excavation; drying; undercutting subgrade and reworking or replacing the undercut material in rock cuts; hauling; disposal of material not used elsewhere on the project; scarification and compaction; and equipment, labor, materials, tools, and incidentals.

Drying required deeper than 6 in. below subgrade elevation will be paid for in accordance with Article 9.7., "Payment for Extra Work and Force Account Method." Excavation and replacement of unsuitable material below subgrade elevations will be performed and paid for in accordance with the applicable bid items. However, if Item 132, "Embankment," is not included in the Contract, payment for replacement of unsuitable material will be paid for in accordance with Article 9.7., "Payment for Extra Work and Force Account Method."

When a slide not due to the Contractor's negligence or operation occurs, payments for removal and disposal of the slide material will be in accordance with Article 9.7., "Payment for Extra Work and Force Account Method." Excavation in backfill areas of retaining walls will not be measured or paid for directly but will be subsidiary to pertinent Items.

Item 112

Subgrade Widening



1. DESCRIPTION

Widen the existing subgrade in accordance with the typical sections.

2. MATERIALS

Furnish water in accordance with Article 204.2., "Materials."

3. CONSTRUCTION

- 3.1. **Preparation of Embankment.** Scarify to a depth of at least 6 in. into existing adjacent embankment slopes before fill is placed.
- 3.2. **Pavement Structure Removal.** Remove material along the edge of the existing pavement. Provide a smooth vertical cut unless otherwise shown on the plans. Conform to the typical sections for the limits of removal unless directed otherwise. Accept ownership of excess material not used in the construction of the subgrade widening. Dispose of excess material in accordance with federal, state, and local regulations.
- 3.3. **Widening.** Remove material in cut sections, and move to fill sections within the project. Use material from cut sections for embankment. Place the material in fill sections in successive lifts to the line and grades shown on the typical sections. Provide additional embankment in accordance with the applicable bid item or Article 9.7., "Payment for Extra Work and Force Account Method," if all excavation has been performed and additional embankment is required to complete the work.
- 3.4. **Compaction.** Compact the widened subgrade in accordance with Article 132.3., "Construction."

4. MEASUREMENT

This Item will be measured by the 100-ft. station along the baseline of each roadbed.

This is a plans quantity measurement Item. The quantity to be paid is the quantity shown in the proposal, unless modified by Article 9.2., "Plans Quantity Measurement." Additional measurements or calculations will be made if adjustments of quantities are required.

5. PAYMENT

The work performed and materials furnished in accordance with this Item and measured as provided under "Measurement" will be paid for at the unit price bid for "Subgrade Widening (Ordinary Compaction)" or "Subgrade Widening (Density Control)." This price is full compensation for excavation; hauling of embankment material from cuts to fills; finishing of the subgrade widening; hauling and disposing of excess excavated material; furnishing and operating equipment; scarifying; shaping; and labor, fuel, materials, tools, and incidentals.

No payment will be made for thickness or width exceeding that shown on the typical sections. "Sprinkling" and "Rolling" will not be paid for directly but will be considered subsidiary to this Item.

Corrections of unstable areas in the widened subgrade will be at the Contractor's expense. In a cut section, work involved in removing and replacing unsuitable material encountered below the finished subgrade will be

paid for as specified under Item 110, "Excavation," when included; otherwise it will be paid for under Article 9.7., "Payment for Extra Work and Force Account Method."

Item 132

Embankment



1. DESCRIPTION

Furnish, place, and compact materials for construction of roadways, embankments, levees, dikes, or any designated section of the roadway where additional material is required.

2. MATERIALS

Furnish approved material capable of forming a stable embankment from required excavation in the areas shown on the plans or from sources outside the right of way. Provide one or more of the following types as shown on the plans:

- **Type A.** Granular material that is free from vegetation or other objectionable material and meets the requirements of Table 1.

Table 1
Testing Requirements

Property	Test Method	Specification Limit
Liquid limit	Tex-104-E	≤ 45
Plasticity index (PI)	Tex-106-E	≤ 15
Bar linear shrinkage	Tex-107-E	≥ 2

Perform the Linear Shrinkage test only as indicated in Tex-104-E.

- **Type B.** Materials such as rock, loam, clay, or other approved materials.
- **Type C.** Material meeting the specification requirements shown on the plans. Type C may be further designated as Type C1, C2, etc.
- **Type D.** Material from required excavation areas shown on the plans.

Meet the requirements of the pertinent retaining wall Items for retaining wall backfill material.

3. CONSTRUCTION

Meet the requirements of Item 7, "Legal Relations and Responsibilities," when off right of way sources are used. Notify the Engineer before opening a material source to allow for required testing. Complete preparation of the right of way in accordance with Item 100, "Preparing Right of Way," for areas to receive embankment.

Backfill tree-stump holes or other minor excavations with approved material and tamp. Restore the ground surface, including any material disked loose or washed out, to its original slope. Compact the ground surface by sprinkling in accordance with Item 204, "Sprinkling," and by rolling using equipment complying with Item 210, "Rolling," when directed.

Scarify and loosen the unpaved surface areas, except rock, to a depth of at least 6 in. unless otherwise shown on the plans. Bench slopes before placing material. Begin placement of material at the toe of slopes. Do not place trees, stumps, roots, vegetation, or other objectionable material in the embankment. Simultaneously recompact scarified material with the placed embankment material. Do not exceed the layer depth specified in Section 132.3.4., "Compaction Methods."

Construct embankments to the grade and sections shown on the plans. Construct the embankment in layers approximately parallel to the finished grade for the full width of the individual roadway cross-sections unless

otherwise shown on the plans. Ensure that each section of the embankment conforms to the detailed sections or slopes. Maintain the finished section, density, and grade until the project is accepted.

- 3.1. **Earth Embankments.** Earth embankment is mainly composed of material other than rock. Construct embankments in successive layers, evenly distributing materials in lengths suited for sprinkling and rolling.
- Treat material in accordance with Item 260, "Lime Treatment (Road-Mixed)" or Item 275, "Cement Treatment (Road-Mixed)" when required. Obtain approval to incorporate rock and broken concrete produced by the construction project in the lower layers of the embankment. Place the rock and concrete outside the limits of the completed roadbed when the size of approved rock or broken concrete exceeds the layer thickness requirements in Section 132.3.4., "Compaction Methods." Cut and remove all exposed reinforcing steel from the broken concrete.
- Move the material dumped in piles or windrows by blading or by similar methods and incorporate it into uniform layers. Featheredge or mix abutting layers of dissimilar material for at least 100 ft. to ensure there are no abrupt changes in the material. Break down clods or lumps of material and mix embankment until a uniform material is attained.
- Apply water free of industrial wastes and other objectionable matter to achieve the uniform moisture content specified for compaction.
- Roll and sprinkle each embankment layer in accordance with Section 132.3.4.1., "Ordinary Compaction," when ordinary compaction is specified. Compact the layer to the required density in accordance with Section 132.3.4.2., "Density Control," when density control is specified.
- 3.2. **Rock Embankments.** Rock embankment is mainly composed of rock. Construct rock embankments in successive layers for the full width of the roadway cross-section with a depth of 18 in. or less. Increase the layer depth for large rock sizes as approved. Do not exceed a depth of 2-1/2 ft. in any case. Fill voids created by the large stone matrix with smaller stones during the placement and filling operations.
- Ensure the depth of the embankment layer is greater than the maximum dimension of any rock. Do not place rock greater than 2 ft. in its maximum dimension, unless otherwise approved. Construct the final layer with graded material so that the density and uniformity is in accordance with Section 132.3.4., "Compaction Methods." Break up exposed oversized material as approved.
- Roll and sprinkle each embankment layer in accordance with Section 132.3.4.1., "Ordinary Compaction," when ordinary compaction is specified. Compact each layer to the required density in accordance with Section 132.3.4.2., "Density Control," when density control is specified. Proof-roll each rock layer as directed, where density testing is not possible, in accordance with Item 216, "Proof Rolling," to ensure proper compaction.
- 3.3. **Embankments Adjacent to Culverts and Bridges.** Compact embankments adjacent to culverts and bridges in accordance with Item 400, "Excavation and Backfill for Structures."
- 3.4. **Compaction Methods.** Begin rolling longitudinally at the sides and proceed toward the center, overlapping on successive trips by at least 1/2 the width of the roller. Begin rolling at the lower side and progress toward the high side on super elevated curves. Alternate roller trips to attain slightly different lengths. Compact embankments in accordance with Section 132.4.1., "Ordinary Compaction," or Section 132.3.4.2., "Density Control," as shown on the plans.
- 3.4.1. **Ordinary Compaction.** Use approved rolling equipment complying with Item 210, "Rolling," to compact each layer. Use specific equipment when required by the plans or the Engineer. Do not allow the loose depth of any layer to exceed 8 in., unless otherwise approved. Bring each layer to the moisture content directed before and during rolling operations. Compact each layer until there is no evidence of further consolidation. Maintain a level layer to ensure uniform compaction. Recompact and refinish the subgrade at no additional expense to the Department if the required stability or finish is lost for any reason.

- 3.4.2. **Density Control.** Compact each layer to the required density using equipment complying with Item 210, "Rolling." Determine the maximum lift thickness based on the ability of the compacting operation and equipment to meet the required density. Do not exceed layer thickness of 16 in. loose or 12 in. compacted material unless otherwise approved. Maintain a level layer to ensure uniform compaction.

The Engineer will use Tex-114-E to determine the maximum dry density (D_a) and optimum moisture content (W_{opt}). Meet the requirements for field density and moisture content in Table 2 unless otherwise shown on the plans.

Table 2
Field Density Control Requirements

Description	Density	Moisture Content
	Tex-115-E	
PI ≤ 15	≥ 98% D_a	
15 < PI ≤ 35	≥ 98% D_a and ≤ 102% D_a	≥ W_{opt} .
PI > 35	≥ 95% D_a and ≤ 100% D_a	≥ W_{opt} .

Each layer is subject to testing by the Engineer for density and moisture content. During compaction, the moisture content of the soil should not exceed the value shown on the moisture-density curve, above optimum, required to achieve:

- 98% dry density for soils with a PI greater than 15 but less than or equal to 35 or
- 95% dry density for soils with PI greater than 35.

Remove small areas of the layer to allow for density tests as required. Replace the removed material and recompact at no additional expense to the Department. Proof-roll in accordance with Item 216, "Proof Rolling," when shown on the plans or as directed. Correct soft spots as directed.

- 3.5. **Maintenance of Moisture and Reworking.** Maintain the density and moisture content once all requirements in Table 2 are met. Maintain the moisture content no lower than 4% below optimum for soils with a PI greater than 15. Rework the material to obtain the specified compaction when the material loses the required stability, density, moisture, or finish. Alter the compaction methods and procedures on subsequent work to obtain specified density as directed.
- 3.6. **Acceptance Criteria.**
- 3.6.1. **Grade Tolerances.**
- 3.6.1.1. **Staged Construction.** Grade to within 0.1 ft. in the cross-section and 0.1 ft. in 16 ft. measured longitudinally.
- 3.6.1.2. **Turnkey Construction.** Grade to within 1/2 in. in the cross-section and 1/2 in. in 16 ft. measured longitudinally.
- 3.6.2. **Gradation Tolerances.** Ensure no more than 1 of the 5 most recent gradation tests is outside the specified limits on any individual sieve by more than 5% when gradation requirements are shown on the plans.
- 3.6.3. **Density Tolerances.** Ensure no more than 1 of the 5 most recent density tests for compaction work is outside the specified density limits, and no test is outside the limits by more than 3 pcf.
- 3.6.4. **Plasticity Tolerances.** Ensure no more than 1 of the 5 most recent PI tests for material is outside the specified limit by more than 2 points.

4. MEASUREMENT

Embankment will be measured by the cubic yard. Measurement will be further defined for payment as follows:

- 4.1. **Final.** The cubic yard will be measured in its final position using the average end area method. The volume is computed between the original ground surface or the surface upon which the embankment is to be constructed and the lines, grades, and slopes of the embankment. In areas of salvaged topsoil, payment for embankment will be made in accordance with Item 160, "Topsoil." Shrinkage or swell factors will not be considered in determining the calculated quantities.
- 4.2. **Original.** The cubic yard will be measured in its original and natural position using the average end area method.
- 4.3. **Vehicle.** The cubic yard will be measured in vehicles at the point of delivery.

When measured by the cubic yard in its final position, this is a plans quantity measurement item. The quantity to be paid is the quantity shown in the proposal, unless modified by Article 9.2., "Plans Quantity Measurement." Additional measurements or calculations will be made if adjustments of quantities are required.

Shrinkage or swell factors are the Contractor's responsibility. When shown on the plans, factors are for informational purposes only.

Measurement of retaining wall backfill in embankment areas is paid for as embankment unless otherwise shown on the plans. Limits of measurement for embankment in retaining wall areas are shown on the plans.

5. PAYMENT

The work performed and materials furnished in accordance with this item and measured as provided under "Measurement" will be paid for at the unit price bid for "Embankment (Final)," "Embankment (Original)," or "Embankment (Vehicle)" of the compaction method and type specified. This price is full compensation for furnishing embankment; hauling; placing, compacting, finishing, and reworking; disposal of waste material; and equipment, labor, tools, and incidentals.

When proof rolling is directed, it will be paid for in accordance with Item 216, "Proof Rolling."

All sprinkling and rolling, except proof rolling, will not be paid for directly but will be considered subsidiary to this item, unless otherwise shown on the plans.

Where subgrade is constructed under this Contract, correction of soft spots in the subgrade will be at the Contractor's expense. Where subgrade is not constructed under this Contract, correction of soft spots in the subgrade will be paid in accordance with Article 9.7., "Payment for Extra Work and Force Account Method."

Item 134

Backfilling Pavement Edges



1. DESCRIPTION

Backfill pavement edges in conformance with the typical sections shown on the plans.

2. MATERIALS

- 2.1. **Backfill Material.** Use backfill material capable of sustaining vegetation unless otherwise specified on the plans. Furnish backfill material of one of the following types:
- 2.1.1. **Type A.** Backfill secured from a source outside the right of way and according to the requirements as shown on the plans.
- 2.1.2. **Type B.** Backfill secured from within the existing right of way as shown on the plans or as directed.
- 2.1.3. **Type C.** Mulch sodding backfill secured from an approved source in accordance with Section 162.2.2., "Mulch Sod."
- 2.2. **Emulsified Asphalt.** Furnish the type specified on the plans and meeting the requirements of Item 300, "Asphalts, Oils, and Emulsions."
- 2.3. **Fertilizer.** Furnish fertilizer in accordance with Article 166.2., "Materials," if specified on the plans.
- 2.4. **Water.** Furnish water required for proper compaction, promotion of plant growth, or emulsion dilution in accordance with Article 168.2., "Materials."

3. CONSTRUCTION

Haul the backfill material to the required location before placing the finish surface course unless directed otherwise. Spread, compact, and shape the backfill material in accordance with the typical sections after placing the finish surface course. Do not drag, push, or scrape material across completed pavement.

- 3.1. **Types A and B Backfill.** Bring the backfill material to the approved moisture content. Shape to the lines and grades shown on the plans, and compact as directed. Blade the roadway side-slopes to a smooth surface after compacting the backfill.
- 3.2. **Type C Backfill.** Place mulch sod in a uniform windrow, and keep moist as directed. Cultivate the area to receive mulch sod to a depth of 4 in. Blade and shape the mulch sod across the area in varying depths as shown on the typical sections to produce a smooth and uniform slope. Roll with a light roller or other suitable equipment. Moisten to the maximum depth of the backfill, after applying fertilizer, as directed.
- 3.3. **Fertilizer.** Distribute fertilizer uniformly in accordance with Article 166.3., "Construction," after final finishing of the backfill material when fertilizer is specified on the plans. Moisten to a depth of 4 in. or to the maximum depth of the backfill, whichever is less, after applying fertilizer.
- 3.4. **Emulsified Asphalt.** Apply the emulsified asphalt mixture in accordance with Article 314.4., "Construction," after final finishing of the backfill material, at the specified amount and rate of application as shown on the plans.

4. MEASUREMENT

This Item will be measured by the 100-ft. station along the baseline of each roadbed.

5. PAYMENT

The work performed and materials furnished in accordance with this Item and measured as provided under "Measurement" will be paid for at the unit price bid for "Backfill" of the type specified. This price is full compensation for furnishing the emulsified asphalt, water, fertilizer, and backfill material; and for equipment, labor, materials, tools, and incidentals.

Item 150

Blading



1. DESCRIPTION

Blade portions of the project limits as shown on the plans or as directed.

2. EQUIPMENT

Provide equipment able to effectively produce the desired results. Use a dual or four-wheel drive power maintainer equipped with pneumatic tires, a blade at least 12 ft. in length, and a wheelbase of no less than 16 ft. when work is measured and paid by the number of hours of blading. Provide a scarifier if the maintainer is not equipped with a scarifier attachment.

3. CONSTRUCTION

Blade all areas to the section, line, and grade shown on the plans. Use a scarifier when necessary to loosen materials before blading. Use hand methods or other means around structures, trees, and other obstructions if doing the work with a blade is impractical. Do not drag, push, or scrape material along or across completed pavement.

4. MEASUREMENT

This Item will be measured by the 100-ft. station along the base line of each roadbed or by the number of hours of blading, including scarifying, performed.

5. PAYMENT

The work performed in accordance with this Item and measured as provided under "Measurement" will be paid for at the unit price bid for "Blading." This price is full compensation for furnishing and operating equipment and for labor, materials, tools, and incidentals.

Work done by hand labor methods adjacent to structures, trees, and other obstructions is not paid for directly but will be considered subsidiary to this Item. Work performed under this Item will not include work specified for payment under other Items.

Item 152

Road Grader Work



1. DESCRIPTION

Construct subgrade and adjacent slopes. Construct portions of the roadway according to the typical sections as shown on the plans where finished grade is uncontrolled. Move earthwork of minor volumes and for short distances only. Move earthwork within the limits as shown on the plans and in at least 500-ft. sections, except on bridge projects.

2. EQUIPMENT

Provide equipment in accordance with Article 150.2., "Equipment."

3. CONSTRUCTION

Remove or rework unsuitable or unstable materials in accordance with Article 110.2., "Construction," or as directed. Grade the roadway and shape to the typical sections shown on the plans. Finish to a profile uniform and consistent with the topography. Scarify existing natural ground or roadbed and compact in accordance with the method shown on the plans and as outlined in Article 132.3., "Construction." Supplement "Road Grader Work" with Item 154, "Scraper Work," Item 156, "Bulldozer Work," or both when shown on the plans. Perform work in accordance with the requirements of the governing Item.

4. MEASUREMENT

This Item will be measured by the 100-ft. station as measured along the baseline of each roadbed or by the square yard.

5. PAYMENT

The work performed in accordance with this Item and measured as provided under "Measurement" will be paid for at the unit price bid for "Road Grader Work (Ordinary Compaction)" or "Road Grader Work (Density Control)." This price is full compensation for furnishing and operating equipment and for labor, materials, tools, and incidentals.

"Sprinkling" and "Rolling" will not be paid for directly but will be subsidiary to this Item. All work involved in removing and replacing or reworking unsuitable or unstable material will be paid for as specified under Item 110, "Excavation," when the Contract includes bid items governed by Item 110, "Excavation," otherwise it will be paid for under Article 9.7., "Payment for Extra Work and Force Account Method." The work performed under this Item will not include work specified for payment under other Items.

Item 154

Scraper Work



1. DESCRIPTION

Excavate, remove, use, or dispose of materials with a scraper. Construct, shape, and rough in earthwork in conformity with the required lines, grades, and typical sections as shown on the plans, or as directed.

2. EQUIPMENT

Use a scraper with a minimum 7.5-cu. yd. flush capacity. Provide a scraper capable of self-loading, or provide power equipment for the scraper to load to capacity. A scraper unit consists of the scraper and any power units necessary.

3. CONSTRUCTION

Perform "Scraper Work" on the areas shown on the plans or as directed. Use suitable excavated materials, including topsoil, for constructing the required roadway sections. Compact embankment in accordance with methods shown on the plans and as outlined in Article 132.3., "Construction." All excavated material becomes the property of the Contractor unless otherwise shown on the plans. Properly dispose of excess excavated material in accordance with federal, state, and local requirements at locations outside the right of way.

Rough in with "Scraper Work." Finish in accordance with Item 150, "Blading," or Item 152, "Road Grader Work," where plans designate "Scraper Work" and either "Blading" or "Road Grader Work" within the same limits.

4. MEASUREMENT

This Item will be measured by the cubic yard hour. A scraper unit cubic yard hour is the flush capacity of the scraper in cubic yards or 70% of the manufacturer's heaped capacity, whichever is less, multiplied by the actual number of hours of scraper work performed.

5. PAYMENT

The work performed in accordance with this Item and measured as provided under "Measurement" will be paid for at the unit price bid for "Scraper Work (Ordinary Compaction)" or "Scraper Work (Density Control)." This price is full compensation for equipment, material removal and disposal, hauling, labor, materials, tools, and incidentals.

"Sprinkling" and "Rolling" will not be paid for directly but will be subsidiary to this Item. The work performed under this Item will not include work specified for payment under other Items.

Item 156

Bulldozer Work



1. DESCRIPTION

Excavate, remove, use, or dispose of materials with a bulldozer. Construct, shape, and finish earthwork in conformity with the required lines, grades, and typical cross-sections as shown on the plans, or as directed.

2. EQUIPMENT

Use a tractor, crawler, or rubber tired type with a blade attachment at least 8 ft. long. Use a scarifier or ripper with the required tractor when necessary. Use equipment of the type specified on the plans, meeting the following requirements:

- 2.1. **Type A.** Manufacturer's rated net flywheel power of less than 150 horsepower based on SAE standard J1349.
- 2.2. **Type B.** Manufacturer's rated net flywheel power of 150 or greater horsepower based on SAE standard J1349.

3. CONSTRUCTION

Perform bulldozer work on the areas as specified on the plans, utilizing equipment as specified above. Rough in with bulldozer work where plans designate "Bulldozer Work" and "Blading," or "Road Grader Work," within the same limits. Finish in accordance with specifications for "Blading" or "Road Grader Work." Compact embankment to ordinary compaction in accordance with Item 132, "Embankment," unless otherwise shown on the plans.

4. MEASUREMENT

This Item will be measured by the actual number of hours of use of the specified type of equipment operated.

5. PAYMENT

The work performed in accordance with this Item and measured as provided under "Measurement" will be paid for at the unit price bid for "Bulldozer Work." This price is full compensation for furnishing and operating equipment, labor, materials, tools, and incidentals. "Sprinkling" and "Rolling" will not be paid for directly but will be subsidiary to this Item. Work performed under this Item will not include work specified for payment under other Items.

Item 158

Specialized Excavation Work



1. DESCRIPTION

Excavate, remove, use, or dispose of materials for erosion control or other specialized needs. Construct, shape, and rough in earthwork in conformance with the required lines, grades, and typical sections as shown on the plans, or as directed.

2. EQUIPMENT

Use equipment of the type specified on the plans unless otherwise approved. Use equipment that is able to consistently and efficiently produce the desired results.

- 2.1. **Dragline.** Self-propelled dragline with a minimum 1/2-cu. yd. bucket.
- 2.2. **Backhoe.** Tractor-mounted backhoe capable of excavating a trench at least 12 in. wide in one pass.
- 2.3. **Hydraulic Excavator.** Hydraulic excavator with a retractable, telescoping, rotatable boom attached to an interchangeable excavating or grading bucket at least 36 in. wide. The entire excavating mechanism must be mounted on a platform that rotates on a turntable assembly.
- 2.4. **Front-End Loader.** Tractor-mounted front-end loader with a minimum bucket capacity of 1-1/4 cu. yd.

3. CONSTRUCTION

Perform "Specialized Excavation Work" on the areas shown on the plans or as directed. Use suitable excavated materials, including topsoil, for constructing the required roadway sections. Compact material placed in embankment to ordinary compaction in accordance with Article 132.3., "Construction," unless otherwise shown on the plans. Accept ownership of all excavated material unless otherwise shown on the plans. Stockpile materials designated salvageable at designated sites. Properly dispose of excess excavated material in accordance with local, state, and federal requirements at locations outside the right of way.

4. MEASUREMENT

This Item will be measured by the hour of work performed for specified equipment or by the cubic yard. Measurement by the cubic yard will be further defined as follows:

- 4.1. **Original.** The cubic yard will be measured in its original position as computed by the method of average end areas.
- 4.2. **Vehicle.** The cubic yard will be measured in vehicles at the point of excavation.

5. PAYMENT

The work performed in accordance with this Item and measured by the hour as provided under "Measurement" will be paid for at the unit price bid for "Specialized Excavation Work" of the equipment type specified or; for cubic yard measurement, payment will be made at the unit price bid for "Specialized Excavation Work (Original)," or "Specialized Excavation Work (Vehicle)." This price is full compensation for hauling and disposing or stockpiling of excess materials and for equipment, labor, materials, tools, and incidentals. "Sprinkling" and "Rolling" will not be paid for directly but will be subsidiary to this Item.

Item 160

Topsoil



1. DESCRIPTION

Furnish and place topsoil to the depths and on the areas shown on the plans.

2. MATERIALS

Use easily cultivated, fertile topsoil that is free from objectionable material and resists erosion. Obtain topsoil from the right of way at sites of proposed excavation or embankment when specified on the plans, or as directed. Secure additional topsoil, if necessary, from approved sources outside the right of way in accordance with the requirements of Article 7.7., "Preservation of Cultural and Natural Resources and the Environment." Ensure that the topsoil obtained from sites outside the right of way has a pH of 5.5 to 8.5, per Tex-128-E. Topsoil is subject to testing by the Engineer. Furnish water in accordance with Article 168.2., "Materials."

3. CONSTRUCTION

Remove and dispose of objectionable material from the topsoil source before beginning the work. Stockpile topsoil, when necessary, in a windrow at designated locations along the right of way line or as directed. Keep source and stockpile areas drained during the period of topsoil removal and leave them in a neat condition when removal is complete. Cultivate the area to a depth of 4 in. before placing topsoil. Spread the topsoil to a uniform loose cover at the thickness specified. Place and shape the topsoil as directed. Water and roll the topsoil with a light roller or other suitable equipment.

4. MEASUREMENT

This Item will be measured by the 100-ft. station along the baseline of each roadbed, by the square yard complete in place, or by the cubic yard in vehicles at the point of delivery.

5. PAYMENT

The work performed and the materials furnished in accordance with this Item and measured as provided under "Measurement" will be paid for at the unit price bid for "Furnishing and Placing Topsoil" of the depth specified on the plans (except for measurement by the cubic yard). This price is full compensation for securing necessary sources and royalties; furnishing topsoil; excavation, loading, hauling, stockpiling and placing; watering; rolling; and equipment, labor, materials, tools, and incidentals. Limits of excavation and embankment for payment are shown in Figure 1.

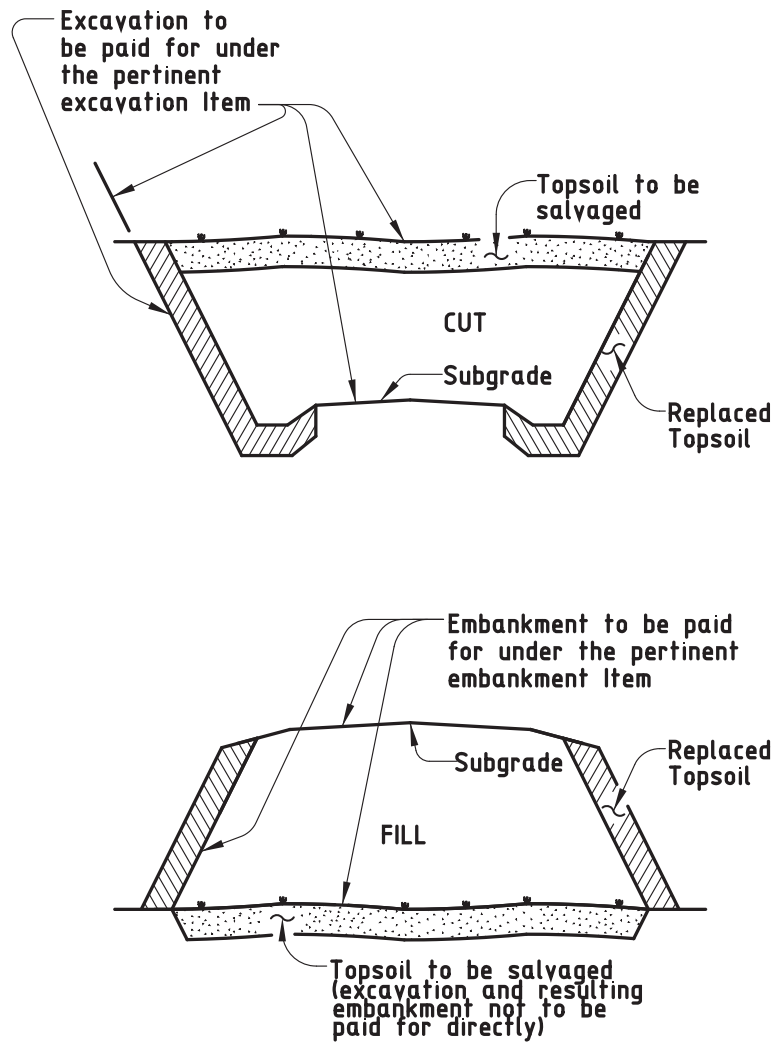

Figure 1
Roadway Cross-Sections Showing Payment for Excavation and Embankment

Item 161

Compost



1. DESCRIPTION

Furnish and place compost as shown on the plans.

2. MATERIALS

Furnish compost that has been produced by aerobic (biological) decomposition of organic matter and meets the requirements of Table 1. Compost feedstock may include, but is not limited to, leaves and yard trimmings, biosolids, food scraps, food-processing residuals, manure or other agricultural residuals, forest residues, bark, and paper. Ensure compost and wood chips do not contain any visible refuse, other physical contaminants, or any substance considered harmful to plant growth. Do not use materials that have been treated with chemical preservatives as a compost feedstock or as wood chips. Do not use mixed municipal solid waste compost. Provide compost meeting all applicable 40 CFR 503 standards for Class A biosolids and TCEQ health and safety regulations as defined in the TAC, Chapter 332, including the time and temperature standards in Subchapter B, Part 23. Meet the requirements of the United States Composting Council (USCC) Seal of Testing Assurance (STA) program.

Before delivery of the compost, provide quality control (QC) documentation that includes the following:

- the feedstock by percentage in the final compost product,
- a statement that the compost meets federal and state health and safety regulations,
- a statement that the composting process has met time and temperature requirements,
- a copy of the producer's STA certification, and
- a copy of the lab analysis, performed by an STA-certified lab, verifying that the compost meets the requirements of Table 1.

Provide a copy of the current TCEQ compliance statement signed by the facility manager when furnishing biosolids compost.

Table 1
Physical Requirements for Compost

Property	Test Method	Requirement
Particle Size	TMECC ¹ 02.02-B, "Sample Sieving for Aggregate Size Classification"	95% passing 5/8" 70% passing 3/8"
Heavy Metals Content	TMECC 04.06, "Heavy Metals and Hazardous Elements": 04.06-As, Arsenic 04.06-Cd, Cadmium 04.06-Cu, Copper 04.06-Pb, Lead 04.06-Hg, Mercury 04.06-Mo, Molybdenum 04.06-Ni, Nickel 04.06-Se, Selenium 04.06-Zn, Zinc	Pass
Salinity	TMECC 04.10-A, "1:5 Slurry Method, Mass Basis"	5.0 dS/m Max ²
pH	TMECC 04.11-A, "1:5 Slurry pH"	5.5-8.5
Maturity	TMECC 05.05-A, "% Emergence and Relative Seedling Vigor"	> 80%
Organic Matter Content	TMECC 05.07-A, "Loss-On-Ignition Organic Matter Method"	25-65% (dry mass)
Stability	TMECC 05.08-B, "Carbon Dioxide Evolution Rate"	≤ 8
Fecal Coliform	TMECC 07.01-B, "Fecal Coliforms"	1,000 MPN/g Max

1. *Test Methods for the Examination of Composting and Compost*, published by the United States Department of Agriculture and the USCC.
2. A soluble salt content up to 10.0 dS/m for compost used in compost-manufactured topsoil will be acceptable.

Maintain compost in designated stockpiles at the producer's site. The Department reserves the right to sample compost at the jobsite. Material may be tested to verify compliance with this Specification by a STA-certified lab. Make payment to the STA-certified lab approved by the Department. Submit lab invoices for passing tests to the Department for reimbursement. Maintain a complete record of all test reports for the previous and current calendar year.

- 2.1. **Compost Manufactured Topsoil (CMT).** Use CMT consisting of 75% topsoil blended with 25% compost measured by volume. Use topsoil conforming to Article 160.2., "Materials."
- 2.2. **Erosion Control Compost (ECC).** Use ECC consisting of 50% untreated wood chips blended with 50% compost measured by volume. Use wood chips less than or equal to 5 in. in length with 95% passing a 2-in. screen and less than 30% passing a 1-in. screen.
- 2.3. **General Use Compost (GUC).** Use GUC consisting of 100% compost.

3. CONSTRUCTION

Prepare the types of compost for use on the project and stockpile at the jobsite.

- 3.1. **Compost Manufactured Topsoil (CMT).** After excavation and embankment work is complete, remove and dispose of objectionable material from the topsoil before blending. Use equipment capable of blending CMT uniformly to the full depth as specified. Roll the CMT with a light corrugated drum.
- 3.2. **Erosion Control Compost (ECC).** Use only on slopes 3:1 or flatter. Apply a 2-in. uniform layer after excavation and embankment work is complete unless otherwise shown on the plans or directed. Use a light roller or other suitable equipment when rolling is specified.
- 3.3. **General Use Compost (GUC).** Apply in a uniform layer as a top dressing on established vegetation to the depth shown on the plans. Do not bury existing vegetation. Apply GUC as a backfill ingredient, in a planting soil mixture, for planting bed preparation, or as mulch, when shown on the plans.

4. MEASUREMENT

This Item will be measured by the 100-ft. station along the baseline of each roadbed, by the square yard complete in place, or by the cubic yard in vehicles at the point of delivery.

For ECC cubic yard measurement, the quantity will be the composite material, compost and topsoil or wood chips.

5. PAYMENT

The work performed and materials furnished in accordance with this Item and measured as provided under "Measurement" will be paid for at the unit price bid for "Compost Manufactured Topsoil," "Erosion Control Compost," and "General Use Compost" as follows:

For measurement by the station and square yard, payment will be for the depth specified;

For measurement by the cubic yard, payment will be made for material measured in vehicles.

This price is full compensation for loading, hauling, stockpiling, blending, placing, rolling, sprinkling, equipment, labor, materials (including topsoil for CMT and wood chips for ECC), tools, and incidentals. Costs associated with passing quality assurance (QA) testing will be paid for in accordance with the requirements of Article 9.7., "Payment for Extra Work and Force Account Method," at invoice price with no add-ons.

Item 162

Sodding for Erosion Control



1. DESCRIPTION

Provide and install grass sod as shown on the plans or as directed.

2. MATERIALS

Use live, growing grass sod of the type specified on the plans. Use grass sod with a healthy root system and dense matted roots throughout the soil of the sod for a minimum thickness of 1 in. Do not use sod from areas where the grass is thinned out. Keep sod material moist from the time it is dug until it is planted. Grass sod with dried roots is unacceptable.

- 2.1. **Block Sod.** Use block, rolled, or solid sod free from noxious weeds, Johnson grass, other grasses, or any matter deleterious to the growth and subsistence of the sod.
- 2.2. **Mulch Sod.** Use mulch sod from an approved source, free from noxious weeds, Johnson grass, other grasses, or any matter deleterious to the growth and subsistence of the sod.
- 2.3. **Fertilizer.** Furnish fertilizer in accordance with Article 166.2., "Materials."
- 2.4. **Water.** Furnish water in accordance with Article 168.2., "Materials."
- 2.5. **Mulch.** Use straw mulch consisting of oat, wheat, or rice straw or hay mulch of either Bermudagrass or prairie grasses. Use straw or hay mulch free of Johnson grass and other noxious and foreign materials. Keep the mulch dry and do not use molded or rotted material.
- 2.6. **Tacking Methods.** Use a tacking agent applied in accordance with the manufacturer's recommendations or a crimping method on all straw or hay mulch operations. Use tacking agents as approved or as specified on the plans.

3. CONSTRUCTION

Cultivate the area to a depth of 4 in. before placing the sod. Plant the sod specified and mulch, if required, after the area has been completed to lines and grades as shown on the plans. Apply fertilizer uniformly over the entire area in accordance with Article 166.3., "Construction," and water in accordance with Article 168.3., "Construction." Plant between the average date of the last freeze in the Spring and 6 weeks before the average date for the first freeze in the Fall according to the Texas Almanac for the project area.

- 3.1. **Sodding Types.**
 - 3.1.1. **Spot Sodding.** Use only Bermudagrass sod. Create furrows parallel to the roadway, approximately 5 in. deep and on 18-in. centers. Sod a continuous row not less than 3 in. wide in the 2 furrows adjacent to the roadway. Place 3-in. squares of sod on 15-in. centers in the remaining furrows. Place sod so that the root system will be completely covered by the soil. Firm all sides of the sod with the soil without covering the sod with soil.
 - 3.1.2. **Block Sodding.** Place sod over the prepared area. Roll or tamp the sodded area to form a thoroughly compacted, solid mat filling all voids in the sodded area with additional sod. Trim and remove all visible netting and backing materials. Keep sod along edges of curbs, driveways, walkways, etc., trimmed until acceptance.

- 3.1.3. **Mulch Sodding.** Mow sod source to no shorter than 4 in., rake and remove cuttings. Disk the sod in 2 directions, cutting the sod to a minimum of 4 in. Excavate the sod material to a depth of no more than 6 in. Keep excavated material moist or it will be rejected. Distribute the mulch sod uniformly over the area to a depth of 6 in. loose, unless otherwise shown on the plans, and roll with a light roller or other suitable equipment.
- Add or reshape the mulch sod to meet the requirements of Section 162.3.2., "Finishing."
- 3.2. **Finishing.** Smooth and shape the area after planting to conform to the desired cross-sections. Spread any excess soil uniformly over adjacent areas or dispose of the excess soil as directed.
- 3.3. **Straw or Hay Mulch.** Apply straw or hay mulch for "Spot Sodding" and "Mulch Sodding" uniformly over the area as shown on the plans. Apply straw mulch at 2 to 2-1/2 tons per acre. Apply hay mulch at 1-1/2 to 2 tons per acre. Use a tacking method over the mulched area.

4. MEASUREMENT

"Spot Sodding," "Block Sodding," and "Straw or Hay Mulch" will be measured by the square yard in its final position. "Mulch Sodding" will be measured by the square yard in its final position or by the cubic yard in vehicles as delivered to the planting site.

5. PAYMENT

The work performed and materials furnished in accordance with this Item and measured as provided under "Measurement" will be paid for at the unit price bid for "Spot Sodding," "Block Sodding," "Straw or Hay Mulch," or "Mulch Sodding." This price is full compensation for securing a source, excavation, loading, hauling, placing, rolling, finishing, furnishing materials, equipment, labor, tools, supplies, and incidentals. Fertilizer will not be paid for directly but will be subsidiary to this Item.

Unless otherwise specified on the plans, water, except for that used for maintaining and preparing the sod before planting, will be measured and paid for in accordance with Item 168, "Vegetative Watering."

Item 164

Seeding for Erosion Control



1. DESCRIPTION

Provide and install temporary or permanent seeding for erosion control as shown on the plans or as directed.

2. MATERIALS

- 2.1. **Seed.** Provide seed from the previous season's crop meeting the requirements of the Texas Seed Law, including the testing and labeling for pure live seed (PLS = Purity × Germination). Furnish seed of the designated species, in labeled unopened bags or containers to the Engineer before planting. Use within 12 mo. from the date of the analysis. When Buffalograss is specified, use seed that is treated with KNO₃ (potassium nitrate) to overcome dormancy.

Use Tables 1–4 to determine the appropriate seed mix and rates as specified on the plans. If a plant species is not available by the producers, the other plant species in the recommended seed mixture will be increased proportionally by the PLS/acre of the missing plant species.

Table 1
Permanent Rural Seed Mix

District and Planting Dates	Clay Soils		Sandy Soils	
	Species and Rates (lb. PLS/acre)		Species and Rates (lb. PLS/acre)	
1 (Paris) Feb. 1–May 15	Green Sprangletop	0.3	Green Sprangletop	0.3
	Sideoats Grama (Haskell)	3.2	Bermudagrass	1.5
	Bermudagrass	1.8	Bahiagrass (Pensacola)	6.0
	Little Bluestem (Native)	1.7	Sand Lovegrass	0.6
	Illinois Bundleflower	1.0	Weeping Lovegrass (Ermelo)	0.8
			Partridge Pea	1.0
2 (Ft. Worth) Feb. 1–May 15	Green Sprangletop (Van Horn)	1.0	Green Sprangletop (Van Horn)	1.0
	Sideoats Grama (Haskell)	1.0	Hooded Windmillgrass (Mariah)	0.2
	Texas Grama (Atascosa)	1.0	Shortspike Windmillgrass (Welder)	0.2
	Hairy Grama (Chaparral)	0.4	Hairy Grama (Chaparral)	0.4
	Shortspike Windmillgrass (Welder)	0.2	Slender Grama (Dilley)	1.0
	Little Bluestem (OK Select)	0.8	Sand Lovegrass (Mason)	0.2
	Purple Prairie Clover (Cuero)	0.6	Sand Dropseed (Borden County)	0.2
	Engelmann Daisy (Eldorado)	0.75	Partridge Pea (Comanche)	0.6
	Illinois Bundleflower	1.3	Little Bluestem (OK Select)	0.8
	Awnless Bushsunflower (Plateau)	0.2	Engelmann Daisy (Eldorado)	0.75
			Purple Prairie Clover	0.3
3 (Wichita Falls) Feb. 1–May 15	Green Sprangletop (Van Horn)	0.6	Green Sprangletop (Van Horn)	1.0
	Sideoats Grama (Haskell)	1.0	Hooded Windmillgrass (Mariah)	0.2
	Texas Grama (Atascosa)	1.0	Shortspike Windmillgrass (Welder)	0.2
	Hairy Grama (Chaparral)	0.4	Hairy Grama (Chaparral)	0.4
	Shortspike Windmillgrass (Welder)	0.2	Sand Lovegrass (Mason)	0.2
	Little Bluestem (OK Select)	0.8	Sand Dropseed (Borden County)	0.2
	Blue Grama (Hachita)	0.4	Partridge Pea (Comanche)	0.6
	Western Wheatgrass (Barton)	1.2	Little Bluestem (OK Select)	0.8
	Galleta Grass (Viva)	0.6	Engelmann Daisy (Eldorado)	0.75
	Engelmann Daisy (Eldorado)	0.75	Purple Prairie Clover (Cuero)	0.3
	Awnless Bushsunflower (Plateau)	0.2		
4 (Amarillo) Feb. 15–May 15	Green Sprangletop	0.3	Green Sprangletop	0.3
	Sideoats Grama (Haskell)	3.6	Weeping Lovegrass (Ermelo)	0.8
	Blue Grama (Hachita)	1.2	Blue Grama (Hachita)	1.0
	Buffalograss (Texoka)	1.6	Sand Dropseed (Borden Co.)	0.3
	Illinois Bundleflower	1.0	Sand Bluestem	1.8
			Purple Prairie Clover	0.5

Table 1 (continued)
Permanent Rural Seed Mix

District and Planting Dates	Clay Soils		Sandy Soils	
	Species and Rates (lb. PLS/acre)		Species and Rates (lb. PLS/acre)	
5 (Lubbock) Feb. 15–May 15	Green Sprangletop	0.3	Green Sprangletop	0.3
	Sideoats Grama (El Reno)	3.6	Weeping Lovegrass (Ermelo)	0.8
	Blue Grama (Hachita)	1.2	Blue Grama (Hachita)	1.0
	Buffalograss (Texoka)	1.6	Sand Dropseed (Borden Co.)	0.3
	Illinois Bundleflower	1.0	Sand Bluestem	1.8
			Purple Prairie Clover	0.5
6 (Odessa) Feb. 1–May 15	Green Sprangletop (Van Horn)	1.0	Green Sprangletop (Van Horn)	1.0
	Sideoats Grama (South Texas)	1.0	Hooded Windmillgrass (Mariah)	0.2
	Blue Grama (Hachita)	0.4	Blue Grama (Hachita)	0.4
	Galleta Grass (Viva)	0.6	Hairy Grama (Chaparral)	0.4
	Shortspike Windmillgrass (Welder)	0.2	Sand Lovegrass (Mason)	0.2
	Pink Pappusgrass (Maverick)	0.6	Sand Dropseed (Borden County)	0.2
	Alkali Sacaton (Saltalk)	0.2	Indian Ricegrass (Rim Rock)	1.6
	Plains Bristlegrass (Catarina Blend)	0.2	Sand Bluestem (Cottle County)	1.2
	False Rhodes Grass (Kinney)	0.1	Little Bluestem (Pastura)	0.8
	Whiplash Pappusgrass (Webb)	0.6	Purple Prairie Clover (Cuero)	0.3
	Arizona Cottontop (La Salle)	0.2		
7 (San Angelo) Feb. 1–May 1	Green Sprangletop (Van Horn)	1.0	Green Sprangletop (Van Horn)	1.0
	Sideoats Grama (Haskell)	1.0	Hooded Windmillgrass (Mariah)	0.2
	Texas Grama (Atascosa)	1.0	Shortspike Windmillgrass (Welder)	0.2
	Hairy Grama (Chaparral)	0.4	Hairy Grama (Chaparral)	0.4
	Shortspike Windmillgrass (Welder)	0.2	Sand Lovegrass (Mason)	0.2
	Little Bluestem (OK Select)	0.4	Sand Dropseed (Borden County)	0.2
	Blue Grama (Hachita)	0.4	Sand Bluestem (Cottle County)	1.2
	Western Wheatgrass (Barton)	1.2	Partridge Pea (Comanche)	0.6
	Galleta Grass (Viva)	0.6	Little Bluestem (OK Select)	0.8
	Engelmann Daisy (Eldorado)	0.75	Engelmann Daisy (Eldorado)	0.75
	Illinois Bundleflower (Sabine)	1.0	Purple Prairie Clover (Cuero)	0.3
8 (Abilene) Feb. 1–May 15	Green Sprangletop (Van Horn)	1.0	Green Sprangletop (Van Horn)	1.0
	Sideoats Grama (Haskell)	1.0	Hooded Windmillgrass (Mariah)	0.2
	Texas Grama (Atascosa)	1.0	Shortspike Windmillgrass (Welder)	0.2
	Hairy Grama (Chaparral)	0.4	Hairy Grama (Chaparral)	0.4
	Shortspike Windmillgrass (Welder)	0.2	Sand Lovegrass (Mason)	0.2
	Little Bluestem (OK Select)	0.4	Sand Dropseed (Borden County)	0.2
	Blue Grama (Hachita)	0.4	Sand Bluestem (Cottle County)	1.2
	Western Wheatgrass (Barton)	1.2	Partridge Pea (Comanche)	0.6
	Galleta Grass (Viva)	0.6	Little Bluestem (OK Select)	0.8
	Engelmann Daisy (Eldorado)	0.75	Engelmann Daisy (Eldorado)	0.75
	Illinois Bundleflower (Sabine)	1.0	Purple Prairie Clover (Cuero)	0.3
9 (Waco) Feb. 1–May 15	Green Sprangletop (Van Horn)	1.0	Green Sprangletop (Van Horn)	1.0
	Sideoats Grama (Haskell)	1.0	Hooded Windmillgrass (Mariah)	0.2
	Texas Grama (Atascosa)	1.0	Shortspike Windmillgrass (Welder)	0.2
	Hairy Grama (Chaparral)	0.4	Hairy Grama (Chaparral)	0.4
	Shortspike Windmillgrass (Welder)	0.2	Slender Grama (Dilley)	1.0
	Little Bluestem (OK Select)	0.8	Sand Lovegrass (Mason)	0.2
	Purple Prairie Clover (Cuero)	0.6	Sand Dropseed (Borden County)	0.2
	Engelmann Daisy (Eldorado)	0.75	Partridge Pea (Comanche)	0.6
	Illinois Bundleflower	1.3	Little Bluestem (OK Select)	0.8
	Awnless Bushsunflower (Plateau)	0.2	Engelmann Daisy (Eldorado)	0.75
			Purple Prairie Clover	0.3
10 (Tyler) Feb. 1–May 15	Green Sprangletop	0.3	Green Sprangletop	0.3
	Bermudagrass	1.8	Bermudagrass	1.8
	Bahiagrass (Pensacola)	9.0	Bahiagrass (Pensacola)	9.0
	Sideoats Grama (Haskell)	2.7	Weeping Lovegrass (Ermelo)	0.5
	Illinois Bundleflower	1.0	Sand Lovegrass	0.5
		Lance-Leaf Coreopsis	1.0	
11 (Lufkin) Feb. 1–May 15	Green Sprangletop	0.3	Green Sprangletop	0.3
	Bermudagrass	1.8	Bermudagrass	2.1
	Bahiagrass (Pensacola)	9.0	Bahiagrass (Pensacola)	9.0
	Sideoats Grama (Haskell)	2.7	Sand Lovegrass	0.5
	Illinois Bundleflower	1.0	Lance-Leaf Coreopsis	1.0

Table 1 (continued)
Permanent Rural Seed Mix

District and Planting Dates	Clay Soils		Sandy Soils	
	Species and Rates (lb. PLS/acre)		Species and Rates (lb. PLS/acre)	
12 (Houston) Jan. 15–May 15	Green Sprangletop	0.3	Green Sprangletop	0.3
	Bermudagrass	2.1	Bermudagrass	2.4
	Sideoats Grama (Haskell)	3.2	Bahiagrass (Pensacola)	10.5
	Little Bluestem (Native)	1.4	Weeping Lovegrass (Ermelo)	1.0
	Illinois Bundleflower	1.0	Lance-Leaf Coreopsis	1.0
13 (Yoakum) Jan. 15–May 15	Green Sprangletop (Van Horn)	1.0	Green Sprangletop (Van Horn)	1.0
	Sideoats Grama (South Texas)	1.0	Hooded Windmillgrass (Mariah)	0.4
	Texas Grama (Atascosa)	1.5	Slender Grama (Dilley)	1.0
	Slender Grama (Dilley)	1.0	Hairy Grama (Chaparral)	0.8
	Shortspike Windmillgrass (Welder)	0.3	Shortspike Windmillgrass (Welder)	0.2
	Halls Panicum (Oso)	0.2	Purple Prairie Clover (Cuero)	0.6
	Plains Bristlegrass (Catarina Blend)	0.2	Partridge Pea (Comanche)	0.6
	Canada Wildrye (Lavaca)	2.0	Englemann Daisy (Eldorado)	1.0
	Illinois Bundleflower (Sabine)	1.3		
	Purple Prairie Clover (Cuero)	0.6		
14 (Austin) Feb. 1–May 15	Green Sprangletop (Van Horn)	1.0	Green Sprangletop (Van Horn)	1.0
	Sideoats Grama (South Texas)	1.0	Hooded Windmillgrass (Mariah)	0.2
	Texas Grama (Atascosa)	1.0	Shortspike Windmillgrass (Welder)	0.2
	Hairy Grama (Chaparral)	0.4	Hairy Grama (Chaparral)	0.4
	Shortspike Windmillgrass (Welder)	0.2	Slender Grama (Dilley)	1.0
	Little Bluestem (OK Select)	0.8	Sand Lovegrass (Mason)	0.2
	Purple Prairie Clover (Cuero)	0.6	Sand Dropseed (Borden County)	0.2
	Engelmann Daisy (Eldorado)	0.75	Partridge Pea (Comanche)	0.6
	Illinois Bundleflower (Sabine)	1.3	Little Bluestem (OK Select)	0.8
	Awnless Bushsunflower (Plateau)	0.2	Englemann Daisy (Eldorado)	0.75
			Purple Prairie Clover	0.3
15 (San Antonio) Feb. 1–May 1	Green Sprangletop (Van Horn)	1.0	Green Sprangletop (Van Horn)	1.0
	Sideoats Grama (South Texas)	1.0	Slender Grama (Dilley)	2.0
	Texas Grama (Atascosa)	1.0	Hairy Grama (Chaparral)	0.6
	Slender Grama (Dilley)	1.0	Shortspike Windmillgrass (Welder)	0.4
	Shortspike Windmillgrass (Welder)	0.2	Pink Pappusgrass (Maverick)	0.6
	Pink Pappusgrass (Maverick)	0.6	Plains Bristlegrass (Catarina Blend)	0.2
	Halls Panicum (Oso)	0.2	Hooded Windmillgrass (Mariah)	0.3
	Plains Bristlegrass (Catarina Blend)	0.2	Multi-flowered False Rhodes Grass	0.1
	False Rhodes Grass (Kinney)	0.1	(Hidalgo)	0.2
	Hooded Windmillgrass (Mariah)	0.2	Arizona Cottontop (La Salle)	
	Arizona Cottontop (La Salle)	0.2		
16 (Corpus Christi) Jan. 1–May 1	Green Sprangletop (Van Horn)	1.0	Green Sprangletop (Van Horn)	1.0
	Sideoats Grama (South Texas)	1.0	Slender Grama (Dilley)	2.0
	Texas Grama (Atascosa)	1.0	Hairy Grama (Chaparral)	0.6
	Slender Grama (Dilley)	1.0	Shortspike Windmillgrass (Welder)	0.4
	Shortspike Windmillgrass (Welder)	0.2	Pink Pappusgrass (Maverick)	0.6
	Pink Pappusgrass (Maverick)	0.6	Plains Bristlegrass (Catarina Blend)	0.2
	Halls Panicum (Oso)	0.2	Hooded Windmillgrass (Mariah)	0.3
	Plains Bristlegrass (Catarina Blend)	0.2	Multi-flowered False Rhodes Grass	0.1
	False Rhodes Grass (Kinney)	0.1	(Hidalgo)	0.2
	Hooded Windmillgrass (Mariah)	0.2	Arizona Cottontop (La Salle)	
	Arizona Cottontop (La Salle)	0.2		
17 (Bryan) Feb. 1–May 15	Green Sprangletop	0.3	Green Sprangletop	0.3
	Bermudagrass	1.5	Bermudagrass	1.5
	Sideoats Grama (Haskell)	3.6	Bahiagrass (Pensacola)	7.5
	Little Bluestem (Native)	1.7	Weeping Lovegrass (Ermelo)	0.6
	Illinois Bundleflower	1.0	Sand Lovegrass	0.6
			Lance-Leaf Coreopsis	1.0

Table 1 (continued)
Permanent Rural Seed Mix

District and Planting Dates	Clay Soils		Sandy Soils	
	Species and Rates (lb. PLS/acre)		Species and Rates (lb. PLS/acre)	
18 (Dallas) Feb. 1–May 15	Green Sprangletop (Van Horn)	1.0	Green Sprangletop (Van Horn)	1.0
	Sideoats Grama (Haskell)	1.0	Hooded Windmillgrass (Mariah)	0.2
	Texas Grama (Atascosa)	1.0	Shortspike Windmillgrass (Welder)	0.2
	Hairy Grama (Chaparral)	0.4	Hairy Grama (Chaparral)	0.4
	Shortspike Windmillgrass (Welder)	0.2	Slender Grama (Dilley)	1.0
	Little Bluestem (OK Select)	0.8	Sand Lovegrass (Mason)	0.2
	Purple Prairie Clover (Cuero)	0.6	Sand Dropseed (Borden County)	0.2
	Engelmann Daisy (Eldorado)	0.75	Partridge Pea (Comanche)	0.6
	Illinois Bundleflower	1.3	Little Bluestem (OK Select)	0.8
	Awnless Bushsunflower (Plateau)	0.2	Engelmann Daisy (Eldorado)	0.75
19 (Atlanta) Feb. 1–May 15	Green Sprangletop	0.3	Green Sprangletop	0.3
	Bermudagrass	2.4	Bermudagrass	2.1
	Sideoats Grama (Haskell)	4.5	Bahiagrass (Pensacola)	7.5
	Illinois Bundleflower	1.0	Sand Lovegrass	0.6
20 (Beaumont) Jan. 15–May 15	Green Sprangletop	0.3	Lance-Leaf Coreopsis	1.0
	Bermudagrass	2.7	Green Sprangletop	0.3
	Sideoats Grama (Haskell)	4.1	Bermudagrass	2.1
	Illinois Bundleflower	1.0	Bahiagrass (Pensacola)	7.5
21 (Pharr) Jan. 15–May 15	Green Sprangletop (Van Horn)	1.0	Green Sprangletop (Van Horn)	1.0
	Sideoats Grama (South Texas)	1.0	Slender Grama (Dilley)	2.0
	Texas Grama (Atascosa)	1.0	Hairy Grama (Chaparral)	0.6
	Slender Grama (Dilley)	1.0	Shortspike Windmillgrass (Welder)	0.4
	Shortspike Windmillgrass (Welder)	0.2	Pink Pappusgrass (Maverick)	0.6
	Pink Pappusgrass (Maverick)	0.6	Plains Bristlegrass (Catarina Blend)	0.2
	Halls Panicum (Oso)	0.2	Hooded Windmillgrass (Mariah)	0.3
	Plains Bristlegrass (Catarina Blend)	0.2	Multi-flowered False Rhoades Grass	0.1
	False Rhodes Grass (Kinney)	0.1	(Hidalgo)	0.2
	Hooded Windmillgrass (Mariah)	0.2	Arizona Cottontop (La Salle)	
Arizona Cottontop (La Salle)	0.2			
22 (Laredo) Jan. 15–May 1	Green Sprangletop (Van Horn)	1.0	Green Sprangletop (Van Horn)	1.0
	Sideoats Grama (South Texas)	1.0	Slender Grama (Dilley)	2.0
	Texas Grama (Atascosa)	1.0	Hairy Grama (Chaparral)	0.6
	Slender Grama (Dilley)	1.0	Shortspike Windmillgrass (Welder)	0.4
	Shortspike Windmillgrass (Welder)	0.2	Pink Pappusgrass (Maverick)	0.6
	Pink Pappusgrass (Maverick)	0.6	Plains Bristlegrass (Catarina Blend)	0.2
	Halls Panicum (Oso)	0.2	Hooded Windmillgrass (Mariah)	0.3
	Plains Bristlegrass (Catarina Blend)	0.2	Multi-flowered False Rhoades Grass	0.1
	False Rhodes Grass (Kinney)	0.1	(Hidalgo)	0.2
	Hooded Windmillgrass (Mariah)	0.2	Arizona Cottontop (La Salle)	
Arizona Cottontop (La Salle)	0.2			
23 (Brownwood) Feb. 1–May 15	Green Sprangletop (Van Horn)	0.6	Green Sprangletop (Van Horn)	1.0
	Sideoats Grama (Haskell)	1.0	Hooded Windmillgrass (Mariah)	0.2
	Texas Grama (Atascosa)	1.0	Shortspike Windmillgrass (Welder)	0.2
	Hairy Grama (Chaparral)	0.4	Hairy Grama (Chaparral)	0.4
	Shortspike Windmillgrass (Welder)	0.2	Sand Lovegrass (Mason)	0.2
	Little Bluestem (OK Select)	0.8	Sand Dropseed (Borden County)	0.2
	Blue Grama (Hachita)	0.4	Partridge Pea (Comanche)	0.6
	Western Wheatgrass (Barton)	1.2	Little Bluestem (OK Select)	0.8
	Galleta Grass (Viva)	0.6	Engelmann Daisy (Eldorado)	0.75
	Engelmann Daisy (Eldorado)	0.75	Purple Prairie Clover (Cuero)	0.3
Awnless Bushsunflower (Plateau)	0.2			

Permanent Rural Seed Mix

District and Planting Dates	Clay Soils		Sandy Soils	
	Species and Rates (lb. PLS/acre)		Species and Rates (lb. PLS/acre)	
24 (El Paso) Feb. 1–May 15	Green Sprangletop (Van Horn)	1.0	Green Sprangletop (Van Horn)	1.0
	Sideoats Grama (South Texas)	1.0	Hooded Windmillgrass (Mariah)	0.2
	Blue Grama (Hachita)	0.4	Blue Grama (Hachita)	0.4
	Galleta Grass (Viva)	0.6	Hairy Grama (Chaparral)	0.4
	Shortspike Windmillgrass (Welder)	0.2	Sand Lovegrass (Mason)	0.2
	Pink Pappusgrass (Maverick)	0.6	Sand Dropseed (Borden County)	0.2
	Alkali Sacaton (Saltalk)	0.2	Indian Ricegrass (Rim Rock)	1.6
	Plains Bristlegrass (Catarina Blend)	0.2	Sand Bluestem (Cottle County)	1.2
	False Rhodes Grass (Kinney)	0.1	Little Bluestem (Pastura)	0.8
	Whiplash Pappusgrass (Webb)	0.6	Purple Prairie Clover (Cuero)	0.3
	Arizona Cottontop (La Salle)	0.2		
25 (Childress) Feb. 1–May 15	Green Sprangletop	0.3	Green Sprangletop	0.3
	Sideoats Grama (El Reno)	2.7	Weeping Lovegrass (Ermelo)	1.2
	Blue Grama (Hachita)	0.9	Sand Dropseed (Borden Co.)	0.5
	Western Wheatgrass	2.1	Sand Lovegrass	0.8
	Galleta	1.6	Purple Prairie Clover	0.5
	Illinois Bundleflower	1.0		

Table 2

Permanent Urban Seed Mix

District and Planting Dates	Clay Soils		Sandy Soils	
	Species and Rates (lb. PLS/acre)		Species and Rates (lb. PLS/acre)	
1 (Paris) Feb. 1–May 15	Green Sprangletop	0.3	Green Sprangletop	0.3
	Bermudagrass	2.4	Bermudagrass	5.4
	Sideoats Grama (Haskell)	4.5		
2 (Ft. Worth) Feb. 1–May 15	Green Sprangletop	0.3	Green Sprangletop	0.3
	Sideoats Grama (El Reno)	3.6	Sideoats Grama (El Reno)	3.6
	Bermudagrass	2.4	Bermudagrass	2.1
	Buffalograss (Texoka)	1.6	Sand Dropseed (Borden Co.)	0.3
3 (Wichita Falls) Feb. 1–May 15	Green Sprangletop	0.3	Green Sprangletop	0.3
	Sideoats Grama (El Reno)	4.5	Sideoats Grama (El Reno)	3.6
	Bermudagrass	1.8	Bermudagrass	1.8
	Buffalograss (Texoka)	1.6	Sand Dropseed (Borden Co.)	0.4
4 (Amarillo) Feb. 15–May 15	Green Sprangletop	0.3	Green Sprangletop	0.3
	Sideoats Grama (El Reno)	3.6	Sideoats Grama (El Reno)	2.7
	Blue Grama (Hachita)	1.2	Blue Grama (Hachita)	0.9
	Buffalograss (Texoka)	1.6	Sand Dropseed (Borden Co.)	0.4
			Buffalograss (Texoka)	1.6
5 (Lubbock) Feb. 15–May 15	Green Sprangletop	0.3	Green Sprangletop	0.3
	Sideoats Grama (El Reno)	3.6	Sideoats Grama (El Reno)	2.7
	Blue Grama (Hachita)	1.2	Blue Grama (Hachita)	0.9
	Buffalograss (Texoka)	1.6	Sand Dropseed (Borden Co.)	0.4
			Buffalograss (Texoka)	1.6
6 (Odessa) Feb. 1–May 15	Green Sprangletop	0.3	Green Sprangletop	0.3
	Sideoats Grama (Haskell)	3.6	Sideoats Grama (Haskell)	2.7
	Blue Grama (Hachita)	1.2	Sand Dropseed (Borden Co.)	0.4
	Buffalograss (Texoka)	1.6	Blue Grama (Hachita)	0.9
			Buffalograss (Texoka)	1.6
7 (San Angelo) Feb. 1–May 1	Green Sprangletop	0.3	Green Sprangletop	0.3
	Sideoats Grama (Haskell)	7.2	Sideoats Grama (Haskell)	3.2
	Buffalograss (Texoka)	1.6	Sand Dropseed (Borden Co.)	0.3
			Blue Grama (Hachita)	0.9
			Buffalograss (Texoka)	1.6
8 (Abilene) Feb. 1–May 15	Green Sprangletop	0.3	Green Sprangletop	0.3
	Sideoats Grama (Haskell)	3.6	Sand Dropseed (Borden Co.)	0.3
	Blue Grama (Hachita)	1.2	Sideoats Grama (Haskell)	3.6
	Buffalograss (Texoka)	1.6	Blue Grama (Hachita)	0.8
			Buffalograss (Texoka)	1.6

Table 2 (continued)
Permanent Urban Seed Mix

District and Planting Dates	Clay Soils		Sandy Soils	
	Species and Rates (lb. PLS/acre)		Species and Rates (lb. PLS/acre)	
9 (Waco) Feb. 1–May 15	Green Sprangletop	0.3	Green Sprangletop	0.3
	Bermudagrass	1.8	Buffalograss (Texoka)	1.6
	Buffalograss (Texoka)	1.6	Bermudagrass	3.6
	Sideoats Grama (Haskell)	4.5	Sand Dropseed (Borden Co.)	0.4
10 (Tyler) Feb. 1–May 15	Green Sprangletop	0.3	Green Sprangletop	0.3
	Bermudagrass	2.4	Bermudagrass	5.4
	Sideoats Grama (Haskell)	4.5		
11 (Lufkin) Feb. 1–May 15	Green Sprangletop	0.3	Green Sprangletop	0.3
	Bermudagrass	2.4	Bermudagrass	5.4
	Sideoats Grama (Haskell)	4.5		
12 (Houston) Jan. 15–May 15	Green Sprangletop	0.3	Green Sprangletop	0.3
	Sideoats Grama (Haskell)	4.5	Bermudagrass	5.4
	Bermudagrass	2.4		
13 (Yoakum) Jan. 15–May 15	Green Sprangletop	0.3	Green Sprangletop	0.3
	Sideoats Grama (South Texas)	4.5	Bermudagrass	5.4
	Bermudagrass	2.4		
14 (Austin) Feb. 1–May 15	Green Sprangletop	0.3	Green Sprangletop	0.3
	Bermudagrass	2.4	Bermudagrass	4.8
	Sideoats Grama (South Texas)	3.6	Buffalograss (Texoka)	1.6
	Buffalograss (Texoka)	1.6		
15 (San Antonio) Feb. 1–May 1	Green Sprangletop	0.3	Green Sprangletop	0.3
	Sideoats Grama (South Texas)	3.6	Bermudagrass	4.8
	Bermudagrass	2.4	Buffalograss (Texoka)	1.6
	Buffalograss (Texoka)	1.6		
16 (Corpus Christi) Jan. 1–May 1	Green Sprangletop	0.3	Green Sprangletop	0.3
	Sideoats Grama (South Texas)	3.6	Bermudagrass	4.8
	Bermudagrass	2.4	Buffalograss (Texoka)	1.6
	Buffalograss (Texoka)	1.6		
17 (Bryan) Feb. 1–May 15	Green Sprangletop	0.3	Green Sprangletop	0.3
	Bermudagrass	2.4	Bermudagrass	5.4
	Sideoats Grama (Haskell)	4.5		
18 (Dallas) Feb. 1–May 15	Green Sprangletop	0.3	Green Sprangletop	0.3
	Sideoats Grama (El Reno)	3.6	Buffalograss (Texoka)	1.6
	Buffalograss (Texoka)	1.6	Bermudagrass	3.6
	Bermudagrass	2.4	Sand Dropseed (Borden Co.)	0.4
19 (Atlanta) Feb. 1–May 15	Green Sprangletop	0.3	Green Sprangletop	0.3
	Bermudagrass	2.4	Bermudagrass	5.4
	Sideoats Grama (Haskell)	4.5		
20 (Beaumont) Jan. 15–May 15	Green Sprangletop	0.3	Green Sprangletop	0.3
	Bermudagrass	2.4	Bermudagrass	5.4
	Sideoats Grama (Haskell)	4.5		
21 (Pharr) Jan. 15–May 15	Green Sprangletop	0.3	Green Sprangletop	0.3
	Sideoats Grama (South Texas)	3.6	Buffalograss (Texoka)	1.6
	Buffalograss (Texoka)	1.6	Bermudagrass	3.6
	Bermudagrass	2.4	Sand Dropseed (Borden Co.)	0.4
22 (Laredo) Jan. 15–May 1	Green Sprangletop	0.3	Green Sprangletop	0.3
	Sideoats Grama (South Texas)	4.5	Buffalograss (Texoka)	1.6
	Buffalograss (Texoka)	1.6	Bermudagrass	3.6
	Bermudagrass	1.8	Sand Dropseed	0.4
23 (Brownwood) Feb. 1–May 15	Green Sprangletop	0.3	Green Sprangletop	0.3
	Sideoats Grama (Haskell)	3.6	Buffalograss (Texoka)	1.6
	Bermudagrass	1.2	Bermudagrass	3.6
	Blue Grama (Hachita)	0.9	Sand Dropseed (Borden Co.)	0.4
24 (El Paso) Feb. 1–May 15	Green Sprangletop	0.3	Green Sprangletop	0.3
	Sideoats Grama (South Texas)	3.6	Buffalograss (Texoka)	1.6
	Blue Grama (Hachita)	1.2	Sand Dropseed (Borden Co.)	0.4
	Buffalograss (Texoka)	1.6	Blue Grama (Hachita)	1.8
25 (Childress) Feb. 1–May 15	Green Sprangletop	0.3	Green Sprangletop	0.3
	Sideoats Grama (El Reno)	3.6	Sand Dropseed (Borden Co.)	0.4
	Blue Grama (Hachita)	1.2	Buffalograss (Texoka)	1.6
	Buffalograss (Texoka)	1.6	Bermudagrass	1.8

Table 3
Temporary Cool Season Seeding

Districts	Dates	Seed Mix and Rates (lb. PLS/acre)
Paris (1), Amarillo (4), Lubbock (5), Dallas (18)	September 1–November 30	Tall Fescue 4.5 Western Wheatgrass 5.6 Wheat (Red, Winter) 34
Odessa (6), San Angelo (7), El Paso (24)	September 1–November 30	Western Wheatgrass 8.4 Wheat (Red, Winter) 50
Waco (9), Tyler (10), Lufkin (11), Austin (14), San Antonio (15), Bryan (17), Atlanta (19)	September 1–November 30	Tall Fescue 4.5 Oats 24 Wheat 34
Houston (12), Yoakum (13), Corpus Christi (16), Beaumont (20), Pharr (21), Laredo (22)	September 1–November 30	Oats 72
Ft. Worth (2), Wichita Falls (3), Abilene (8), Brownwood (23), Childress (25)	September 1–November 30	Tall Fescue 4.5 Western Wheatgrass 5.6 Cereal Rye 34

Table 4
Temporary Warm Season Seeding

Districts	Dates	Seed Mix and Rates (lb. PLS/acre)
All	May 1–August 31	Foxtail Millet 34

- 2.2. **Fertilizer.** Use fertilizer in conformance with Article 166.2., “Materials.”
- 2.3. **Vegetative Watering.** Use water that is clean and free of industrial wastes and other substances harmful to the growth of vegetation.
- 2.4. **Mulch.**
- 2.4.1. **Straw or Hay Mulch.** Use straw or hay mulch in conformance with Section 162.2.5., “Mulch.”
- 2.4.2. **Cellulose Fiber Mulch.** Use only cellulose fiber mulches that are on the Approved Products List, *Erosion Control Approved Products*. (<http://www.txdot.gov/business/resources/erosion-control.html>) Submit one full set of manufacturer’s literature for the selected material. Keep mulch dry until applied. Do not use molded or rotted material.
- 2.5. **Tacking Methods.** Use a tacking agent applied in accordance with the manufacturer’s recommendations or a crimping method on all straw or hay mulch operations. Use tacking agents as approved or as specified on the plans.

3. CONSTRUCTION

Cultivate the area to a depth of 4 in. before placing the seed unless otherwise directed. Use approved equipment to vertically track the seedbed as shown on the plans or as directed. Cultivate the seedbed to a depth of 4 in. or mow the area before placement of the permanent seed when performing permanent seeding after an established temporary seeding. Plant the seed specified and mulch, if required, after the area has been completed to lines and grades as shown on the plans.

- 3.1. **Broadcast Seeding.** Distribute the seed or seed mixture uniformly over the areas shown on the plans using hand or mechanical distribution or hydro-seeding on top of the soil unless otherwise directed. Apply the mixture to the area to be seeded within 30 min. of placement of components in the equipment when seed and water are to be distributed as a slurry during hydro-seeding. Roll the planted area with a light roller or other suitable equipment. Roll sloped areas along the contour of the slopes.

- 3.2. **Straw or Hay Mulch Seeding.** Plant seed according to Section 164.3.1., "Broadcast Seeding." Apply straw or hay mulch uniformly over the seeded area immediately after planting the seed or seed mixture. Apply straw mulch at 2 to 2.5 tons per acre. Apply hay mulch at 1.5 to 2 tons per acre. Use a tacking method over the mulched area.
- 3.3. **Cellulose Fiber Mulch Seeding.** Plant seed in accordance with Section 164.3.1., "Broadcast Seeding." Apply cellulose fiber mulch uniformly over the seeded area immediately after planting the seed or seed mixture at the following rates.
- Sandy soils with slopes of 3:1 or less—2,500 lb. per acre.
 - Sandy soils with slopes greater than 3:1—3,000 lb. per acre.
 - Clay soils with slopes of 3:1 or less—2,000 lb. per acre.
 - Clay soils with slopes greater than 3:1—2,300 lb. per acre.
- Cellulose fiber mulch rates are based on dry weight of mulch per acre. Mix cellulose fiber mulch and water to make a slurry and apply uniformly over the seeded area using suitable equipment.
- 3.4. **Drill Seeding.** Plant seed or seed mixture uniformly over the area shown on the plans at a depth of 1/4 to 1/3 in. using a pasture or rangeland type drill unless otherwise directed. Plant seed along the contour of the slopes.
- 3.5. **Straw or Hay Mulching.** Apply straw or hay mulch uniformly over the area as shown on the plans. Apply straw mulch at 2 to 2.5 tons per acre. Apply hay mulch at 1.5 to 2 tons per acre. Use a tacking method over the mulched area.

Apply fertilizer in conformance with Article 166.3., "Construction." Seed and fertilizer may be distributed simultaneously during "Broadcast Seeding" operations, provided each component is applied at the specified rate. Apply half of the required fertilizer during the temporary seeding operation and the other half during the permanent seeding operation when temporary and permanent seeding are both specified for the same area.

Water the seeded areas at the rates and frequencies as shown on the plans or as directed.

4. MEASUREMENT

This Item will be measured by the square yard or by the acre.

5. PAYMENT

The work performed and the materials furnished in accordance with this Item and measured as provided under "Measurement" will be paid for at the unit price bid for "Broadcast Seeding (Perm)" of the rural or urban seed mixture and sandy or clay soil specified, "Broadcast Seeding (Temp)" of warm or cool season specified, "Straw or Hay Mulch Seeding (Perm)" of the rural or urban seed mixture and sandy or clay soil specified, "Straw or Hay Mulch Seeding (Temp)" of warm or cool season specified, "Cellulose Fiber Mulch Seeding (Perm)" of the rural or urban seed mixture and sandy or clay soil specified, "Cellulose Fiber Mulch Seeding (Temp)" of warm or cool season specified, "Drill Seeding (Perm)" of the rural or urban seed mixture and sandy or clay soil specified, "Drill Seeding (Temp)" of warm or cool season specified, and "Straw or Hay Mulching." This price is full compensation for furnishing materials, including water for hydro-seeding and hydro-mulching operations, mowing, labor, equipment, tools, supplies, and incidentals. Fertilizer will not be paid for directly but will be subsidiary to this Item. Water for irrigating the seeded area, when specified, will be paid for under Item 168, "Vegetative Watering."

Item 166

Fertilizer



1. DESCRIPTION

Provide and distribute fertilizer over areas specified on the plans.

2. MATERIALS

Use a complete fertilizer containing nitrogen (N), phosphoric acid (P), and potash (K) nutrients unless otherwise specified on the plans. Ensure at least 50% of the nitrogen component is a slow-release sulfur-coated urea. Ensure that fertilizer is in an acceptable condition for distribution in containers labeled with the analysis. Fertilizer is subject to testing by the Texas A&M Feed and Fertilizer Control Service in accordance with the Texas Fertilizer Law.

3. CONSTRUCTION

Deliver and apply the complete fertilizer uniformly at a rate equal to 60 lb. of nitrogen per acre or at the analysis and rate specified on the plans.

Apply fertilizer as a dry material and do not mix with water to form a slurry.

Incorporate fertilizer during seedbed preparation as specified on the plans.

4. MEASUREMENT

When fertilizer is specified on the plans to be a pay item, measurement will be by the acre of surface area covered or by the ton (2,000 lb.). Measurement by the ton will use guaranteed weight of bags or containers as shown by the manufacturer or certified scales meeting the requirements of Item 520, "Weighing and Measuring Equipment," unless otherwise approved.

5. PAYMENT

Unless otherwise specified on the plans, the work performed, materials furnished, equipment, labor, tools, and incidentals will not be paid for directly but will be subsidiary to pertinent bid items.

When fertilizer is specified on the plans to be a pay item, the work performed and materials furnished in accordance with this Item and measured as provided under "Measurement" will be paid for at the unit price bid for "Fertilizer." This price is full compensation for furnishing materials and performing operations.

Item 168

Vegetative Watering



1. DESCRIPTION

Provide and distribute water to promote growth of vegetation as directed.

2. MATERIALS

Use water that is clean and free of industrial wastes and other substances harmful to the growth of vegetation.

3. CONSTRUCTION

Apply water when directed. Furnish and operate equipment to distribute water at a uniform and controllable rate. Ensure that watering does not erode soil or plantings. Apply water in the required quantity where shown on the plans or as directed.

4. MEASUREMENT

This Item will be measured by the 1,000 gal. as applied.

5. PAYMENT

The work performed and materials furnished in accordance with this Item and measured as provided under "Measurement" will be paid for at the unit price bid for "Vegetative Watering." This price is full compensation for furnishing and operating watering equipment and measuring devices and for furnishing and applying water, including hauling, equipment, labor, and incidentals.

Item 169

Soil Retention Blankets



1. DESCRIPTION

Provide and install soil retention blankets (SRB) as shown on the plans or as directed.

2. MATERIALS

Provide only SRB that meet the requirements of DMS-6370, "Soil Retention Blankets," and are on the Approved Products List, *Erosion Control Approved Products*. (<http://www.txdot.gov/business/resources/erosion-control.html>) Use material of the following class and type as shown on the plans and provide a copy of the manufacturer's label for the selected product.

2.1. Class 1: Slope Protection.

2.1.1. Type A. Slopes 3:1 or flatter—clay soils,

2.1.2. Type B. Slopes 3:1 or flatter—sandy soils,

2.1.3. Type C. Slopes steeper than 3:1—clay soils, and

2.1.4. Type D. Slopes steeper than 3:1—sandy soils.

2.2. Class 2: Flexible Channel Liners.

2.2.1. Type E. Biodegradable materials with shear stress less than 2.0 psf,

2.2.2. Type F. Biodegradable materials with shear stress less than 4.0 psf,

2.2.3. Type G. Nonbiodegradable materials with shear stress less than 6.0 psf, and

2.2.4. Type H. Nonbiodegradable materials with shear stress less than 8.0 lb. psf.

3. CONSTRUCTION

Provide a copy of the manufacturer's installation instructions to the Engineer before placement of the material. Place the SRB within 24 hr. after the seeding or sodding operation, or when directed. Install and anchor the SRB in strict accordance with the recommendations contained within the manufacturer's published literature. Installation includes the repair of ruts, reseeding or resodding, and the removal of rocks, clods, and other foreign materials which may prevent contact of the blanket with the soil.

4. MEASUREMENT

This Item will be measured by the square yard of surface area covered.

5. PAYMENT

The work performed and materials furnished in accordance with this Item and measured as provided under "Measurement" will be paid for at the unit price bid for "Soil Retention Blankets" of the class and type specified. This price is full compensation for equipment, materials, labor, tools, and incidentals.

Item 170

Irrigation System



1. DESCRIPTION

Furnish and install an irrigation system as shown on the plans.

2. MATERIALS

Unless otherwise shown on the plans, use materials that meet the following:

- 2.1. **Irrigation Pipe.** Use polyvinyl chloride (PVC) pipe meeting ASTM D2241, SDR 13.5, SDR 17, SDR 21; or ASTM D1785, Schedule 40.
- 2.2. **Fittings.** Furnish fittings as shown on the plans. PVC fittings must meet ASTM D2466.
- 2.3. **Encasement Pipe.** Use PVC pipe meeting ASTM D1785, Schedule 40, with an inside diameter at least 1 in. larger than the outside diameter of the irrigation pipe, unless otherwise shown on the plans.
- 2.4. **Low-Voltage Wire.** Use minimum 14 gauge UL-approved wire for direct burial.
- 2.5. **Bentonite Slurry.** Use a viscous mixture of commercial bentonite and fresh water containing 2% to 8% bentonite by weight.
- 2.6. **Accessories.** Use valves, sprinkler heads, and controllers that meet the requirements shown on the plans. Use backflow preventers that meet the requirements of the controlling water utility authority.
- 2.7. **Electrical Service.** Use materials meeting the requirements of Section 170.3.1., "Electrical Service," for installations requiring over 100 V.

3. CONSTRUCTION

Perform irrigation system work under the supervision of a person possessing an irrigator's license issued by the TCEQ. Provide documentation of this license. Follow the codes of the controlling utility authority for water and electrical connection and service.

Coordinate irrigation system installation with plant installation, when plant installation is specified, to ensure that watering requirements are met. Prevent damage to vegetation, slopes, utilities, structures, and other amenities. Repair any damage within the right of way caused by the Contractor. Perform the following activities as required:

- 3.1. **Electrical Service.** Construct installations requiring over 100 V in accordance with the details shown on the plans and the pertinent requirements of the following:
 - Item 618, "Conduit,"
 - Item 620, "Electrical Conductors,"
 - Item 622, "Duct Cable,"
 - Item 624, "Ground Boxes," and
 - Item 628, "Electrical Services."
- 3.2. **Excavation and Trenching.** Excavate and trench to a sufficient depth to provide for a minimum of 12-in. soil cover for all lines or as shown on the plans. Use common trenches for irrigation lines and wire runs where

feasible. Protect trenches and boring pits less than 5 ft. deep using approved methods. Protect trenches and boring pits 5 ft. deep or deeper in accordance with Item 402, "Trench Excavation Protection," and Item 403, "Temporary Special Shoring."

- 3.3. **Boring.** Bore at the locations shown on the plans or as directed. Avoid weakening or damaging roadways or other facilities. Bore the lengths in one direction only. Maintain horizontal and vertical alignment to an accuracy of 1 in. in 10 ft. Use water or other approved fluids in connection with boring operations only to lubricate cuttings.
- Bentonite slurry may be used in unconsolidated soil formations to consolidate cuttings for the bit, seal the walls of the hole, and furnish lubrication for subsequent removal of cuttings and installation of the pipe immediately thereafter.
- 3.4. **Water Jetting.** Use water jetting only when shown on the plans or approved in writing. Water jet the lengths in one direction only. Cease operations and complete all necessary work by boring when jetting operations fail to produce a smooth stable hole.
- 3.5. **Encasement.** Provide a minimum of 12 in. of cover over encasement pipe. Cover is measured to the top of the subgrade for paved areas and to the bottom of the slab for sidewalks or non-load-bearing slabs.
- 3.6. **Pipe and Valve Assembly.** Assemble pipe and fittings as recommended by the manufacturers. Clean pipe and fittings of dust, dirt, and moisture before assembly. Make connections between plastic pipe and metal valves with threaded fittings and plastic adapters. Install backflow preventers as required by ordinances of the controlling water utility authority. Install pipe, valves, and valve boxes a minimum of 12 in. from sidewalks, buildings, walls, and other objects, or as directed.
- 3.7. **Sprinkler Heads and Drip Tubing.** Install sprinkler heads and drip tubing in accordance with the manufacturer's recommendations at locations shown on the plans or as directed.
- 3.8. **Controller.** Install controllers in accordance with the manufacturer's recommendations at locations shown on the plans or as directed.
- 3.9. **Low-Voltage Wire.** Install wire in trenches below the pipe or in a minimum 1-in. PVC pipe with at least 12 in. of cover over its entire run. Install wire in continuous lengths. Splice wire, if required, in valve boxes using waterproof materials.
- 3.10. **Closing and Flushing of PVC Pipe.** Cap or plug pipe after installation to prevent entry of foreign materials that would obstruct the flow of water. Leave caps or plugs in place until removal is necessary for completion of the installation. Thoroughly flush all water lines.
- 3.11. **Hydrostatic Tests.** Notify the Engineer in writing at least 48 hr. before testing. Center load all pipe with enough backfill to prevent arching or slipping while under pressure. After all welded joints have cured for at least 24 hr., test the main lines from the meter to the valves, with all valves closed, for at least 2 consecutive hours by applying a continuous and static minimum 80-psi water pressure. Repair leaks if necessary and retest. Maintain the lines under static pressure for 24 hr. without leaks before final approval.
- 3.12. **Backfill and Compaction.** Backfill trenches and other excavations with soil free of objectionable material after the irrigation system is fully operational, all tests and inspections have been performed, and the results are approved. Backfill and compact in 8-in. layers. Smooth and shape disturbed soil to final grade or as directed.

4. MEASUREMENT

This Item will be measured by the lump sum or by each complete system.

5. PAYMENT

For “lump sum” measurement, the work performed and the materials furnished in accordance with this Item and measured as provided under “Measurement” will be paid for at the unit price bid for “Irrigation System.” For “each” measurement, the work performed and the materials furnished in accordance with this Item and measured as provided under “Measurement” will be paid for at the unit price bid for “Irrigation System.” of the design specified. This price is full compensation for furnishing and installing all components; flushing and testing water lines; furnishing and operating equipment; and labor, tools, and incidentals. Protection methods for excavations 5 ft. deep or deeper will be measured and paid for as required under Item 402, “Trench Excavation Protection,” or Item 403, “Temporary Special Shoring.” Electrical work required in accordance with Section 170.3.1., “Electrical Service,” will be measured and paid for under Item 628, “Electrical Services.” Power and water consumed will be paid for by the Department unless otherwise shown on the plans. Backflow preventer, system inspection, and maintenance fees will be paid by the Department unless otherwise shown on the plans.

Item 180

Wildflower Seeding



1. DESCRIPTION

Prepare the surface, provide and sow wildflower seed as shown on the plans or as directed.

2. MATERIALS

Provide seed of the previous season's crop meeting the requirements of the Texas Seed Law, including the testing and labeling for pure live seed (PLS = purity × germination). Furnish seed of the designated species in unopened bags or containers to the Engineer before planting, with labels showing the date of the analysis to be no more than 12 mo. before the time of use.

3. EQUIPMENT

Use equipment shown on the plans or as directed that will evenly distribute the seed over the area.

4. CONSTRUCTION

Mow locations designated for wildflower planting to an approximate height of 4 in. Distribute the seed or seed mixture uniformly at the rates and locations shown on the plans or as directed.

5. MEASUREMENT

This Item will be measured by the acre.

6. PAYMENT

The work performed in accordance with this Item and measured as provided under "Measurement" will be paid for at the unit price bid for "Wildflower Seeding." This price is full compensation for seed, equipment, labor, tools, and incidentals.

Item 192

Landscape Planting



1. DESCRIPTION

Provide and install plants and related materials at designated locations. Maintain plants, related materials, and landscaped areas at the specified frequency.

2. MATERIALS

Comply with the latest standards as follows, unless otherwise shown on the plans.

- The most recently published edition of the *American Standard for Nursery Stock* (ANSI Z60.1).
- *Standardized Plant Names* published by the American Joint Committee on Horticultural Nomenclature.
- Meet additional requirements for plants and related materials as shown on the plans.

2.1. **Plants.** Provide nursery-grown plants unless otherwise shown on the plans. Provide vigorous, healthy, well-rooted, plants with well-formed crowns, true to sizes, and of typical shape and characteristics of the species. Provide plants with nametags attached showing the genus, species, and specified variety.

2.2. **Rejection of Plants.** Plants with any of the following characteristics are subject to rejection:

- disease or insect infestation, including eggs and larvae;
- dried or damaged root system or crown;
- excessive abrasion of the bark;
- prematurely opened or damaged buds;
- disfiguring knots;
- evidence of heat, freeze, or wind burn, mold, sun scald, or similar conditions;
- damaged, pruned, crooked, or multiple leaders, unless multiple leaders are specified or are normal for the species;
- cut limbs over 3/4 in. in diameter that have not completely callused;
- dry, soggy, loose, cracked, broken, misshapen, or undersized root balls;
- processed balled roots (bench balled);
- root balls encased in impervious material;
- overgrown or root-bound plants;
- undersized or unsound containers;
- stock not well established in containers;
- containers with less than 3/4 planting medium depth;
- an abnormal balance between height and spread for the species;
- missing or broken serialized locking tags, when specified;
- any condition that does not conform to the plans or nursery stock standards; or
- conditions that would prevent thriving growth or cause an unacceptable appearance.

2.3. **Backfill and Plant Soil Mix.** Use soil excavated from the plant pits or beds or provide a loose, friable soil mix as shown on the plans. Provide a soil mix free of reproductive parts of weeds and grasses, harmful substances, and detrimental amounts of foreign matter. Use compost in accordance with Section 161.2.3., "General Use Compost (GUC)," when specified on the plans.

- 2.4. **Mulch.** Provide loose, organic mulch derived from plants unless other types are shown on the plans. Use mulch free of excessive amounts of leaves, sticks, harmful substances, and detrimental amounts of soil or other foreign matter.
- 2.5. **Water.** Furnish water in accordance with Article 168.2., "Materials."
- 2.6. **Fertilizer.** Use fertilizer in accordance with Article 166.2., "Materials," unless otherwise shown on the plans.
- 2.7. **Other Materials.** Provide additional incidental materials associated with landscape planting that meet the requirements shown on the plans.

3. CONSTRUCTION

Prevent damage to vegetation, slopes, utilities, structures, and other amenities. Repair any damage within the right of way caused by the Contractor at no additional expense to the Department. Provide and document a licensed pesticide applicator for the treatment of insects, diseases, animals, and vegetation in accordance with the Texas Department of Agriculture in the appropriate use category.

- 3.1. **Plant Inspection Before Delivery.** Plants are subject to inspection at the nursery or location of collection. Provide and use serialized locking tags on plants selected by the Engineer as directed.
- 3.2. **Plant Delivery.** Notify the Engineer at least 48 hr. before delivering plants to the worksite. Coordinate with the Engineer for inspection and approval of materials upon delivery. Remove rejected plants from the worksite and replace as directed.
- 3.3. **Mark Plant Locations and Bed Outlines.** Provide and install coded markings, such as wooden stakes, to mark the locations, type of plants, and the outline of planting beds. Obtain approval of the plant and bed locations before excavation begins.
- 3.4. **Plant Pit Excavation.** Excavate pits for container, balled and burlapped (B&B), and fabric bag grown stock to the depth shown on the plans or at least the depth of the root ball. Excavate pits for bare root plants equal to the depth of the root system. Excavate pits on slopes using measurements shown on the plans or at least the depth of the root ball based on the uphill side of the pit. Excavate the receiving pits for mechanically transplanted plants with the same type and size equipment used to dig the plants.

Provide a minimum horizontal dimension of 12 in. between the root ball and pit walls for the following, unless otherwise shown on the plans:

- 15-gal. or larger pots,
- 14-in. or larger boxes, and
- larger than 14-in. root balls of B&B and fabric bag grown plants.

Provide a minimum horizontal dimension of 2 times the root ball diameter across the pit for the following, unless otherwise shown on the plans:

- less than 15-gal. pots, and
- 14-in. or smaller root balls of B&B and fabric bag grown plants.

Provide a minimum pit diameter for bare root plants that permits the roots to spread without crowding or curving around the walls of the pit.

- 3.5. **Plant Installation.** Install plants within 24 hr. of excavating plant pits. Scarify the walls of pits as plant installation begins. Center all plants in a pit, except those mechanically collected, backfill in lifts, each lift 1/3 of the depth of the root ball, and fill the pit with water after each lift to remove air pockets. Prune protruding roots, from the root ball, for mechanically collected plants, to a point even with the cutting blades. Place the plant in the pit and work sand between the pit walls and the root ball with water until the sand fills all the cavities.

Apply fertilizer according to the plans. Ensure that the top of the root ball remains at the grade shown on the plans after final settlement.

- 3.6. **Plant Basin Construction.** Construct a basin at least 8 in. deep with an inside diameter equal to the pit diameter and with a level top around the plant unless otherwise shown on the plans. Use excavated soil from the plant pits or beds, backfill material, or other approved material for the basin. Spread excess excavated materials over the right of way as directed or remove and dispose of material in accordance with local, state, and federal requirements at locations outside the right of way.
- 3.7. **Watering.** Coordinate the planting work to ensure that an irrigation system, when specified, operates properly to meet the watering requirements. Apply water to plants or planting areas at the rate and frequency specified for an irrigation system or for the application method shown on the plans. Keep the ground and backfill moist at least 12 in. around the entire root ball if a watering rate and frequency are not specified.
- 3.8. **Using Antitranspirants.** Apply antitranspirants, when shown on the plans, in accordance with the manufacturer's instructions.
- 3.9. **Pruning.** Accomplish pruning in accordance with ANSI A300 (Part 1) pruning standards unless otherwise shown on the plans or as directed. Retain the natural shape of plants according to the species. Limit pruning to removal of dead and broken branches, and an additional amount as specified or directed to improve the appearance and health of plants.
- Prune B&B and collected plants to reduce the original crown by approximately 20% by removing interior branches, entangled limbs, and small branches unless otherwise shown on the plans. Prune to develop the central leader or leaders. Remove and dispose of pruning debris.
- Apply wound dressing on oak (*Quercus*) species within 20 min. of causing bark damage or making a pruning cut. Apply wound dressing on other plants when shown on the plans or as directed. Use wound dressing in accordance with the pruning standards.
- 3.10. **Plant Support Installation.** Install plant supports such as staking, guying, and bracing as shown on the plans. Support and keep plants in a vertical position or as directed.
- 3.11. **Tree Trunk Protection.** Install tree trunk protection guards when shown on the plans and in accordance with the manufacturer's instructions.
- 3.12. **Landscape Edge Installation.** Install landscape edging when shown on the plans and in accordance with the manufacturer's instructions.
- 3.13. **Plant Bed Preparation.** Prepare the bed and install the planting soil mix, vegetation barrier, and other materials as shown on the plans.
- 3.14. **Mulching.** Mulch plant basins and beds to a depth of 2 in. unless otherwise shown on the plans.
- 3.15. **Maintenance.** Begin maintenance of each plant under this Item when the installation is completed and approved, or as directed. Perform maintenance until final acceptance of the project, or for a minimum of 90 days should the final acceptance occur less than 90 days after the plant installation is completed and approved, by following the work schedule and frequencies shown on the plans. Perform the minimum requirements stated below if a work schedule and frequency are not shown on the plans.
- 3.15.1. **Watering.** Water in accordance with Section 192.3.7., "Watering."
- 3.15.2. **Mowing, Trimming, and Edging.** Mow, trim, and edge the designated locations. Mow, trim, and edge every 15 days during the growing season or as directed, mowing at a 3-4 in. height. Keep cord trimmers at least 1 ft. from plants to prevent damage to the plants. Plants damaged during the maintenance work are subject to rejection and replacement according to Section 192.3.15.9., "Plant Replacement."

- 3.15.3. **Plant Basin, Bed, and Worksite Maintenance.** Chemically control weeds and unwanted grasses in plant basins, beds, along and in structures, and around existing plants every 15 days, unless otherwise directed. Reshape plant basins and beds every 30 days to conform to the plans. Maintain mulch in accordance with Section 192.3.14., "Mulching." Ensure that herbicides do not contact desirable plants. Follow the manufacturer's instruction for handling and applying herbicides.
- 3.15.4. **Plant Supports.** Replace, repair, and adjust supports to meet the requirements of the plans and in accordance with Section 192.3.10., "Plant Support Installation." Adjust staking and guying to prevent girdling of plant trunks. Remove or dispose of support material as directed.
- 3.15.5. **Pruning.** Prune as shown on the plans and in accordance with Section 192.3.9., "Pruning."
- 3.15.6. **Insect, Disease, and Animal Inspection and Treatment.** Inspect plants and planted areas at least every 15 days. Notify the Engineer of concerns and problems and recommend corrective measures in writing for approval. Treat the plants and planted areas in accordance with TDA or TSPCB laws and regulations. Follow the manufacturer's instructions for handling and applying pesticides.
- 3.15.7. **Litter and Debris Collection and Disposal.** Collect litter and debris within the worksite before mowing and trimming at least every 15 days. Dispose of litter and debris as directed.
- 3.15.8. **Tree Trunk Wrap and Protection Guard Removal and Disposal.** Remove and dispose of tree trunk wrapping material and protection guards as directed.
- 3.15.9. **Plant Replacement.** Remove and dispose of dead and damaged plants from the worksite as directed. Replace plants as originally specified within 10 days of notification. Plant replacement must be completed and approved before payment is approved when notification is made between the starting date and day 30 of the maintenance work, according to Section 192.5.2., "30-Day Payment." Plant replacement must be completed and approved before payment is approved when notification is made between days 31 and 60 of the maintenance work, according to Section 192.5.3., "60-Day Payment." Plant replacement must be completed and approved before payment is approved when notification is made between days 61 and either the date of project final acceptance or day 90 of the maintenance work, whichever occurs later, according to Section 192.5.4., "Final Payment."

4. MEASUREMENT

This Item will be measured by each plant. When mulch is specified as a separate pay item, it will be measured by the cu. yd. or the sq. yd. When plant soil mix is specified as a separate pay item, it will be measured by the cu. yd. When landscape edge is specified as a separate pay item, it will be measured by the ft. When plant bed preparation is specified as a separate pay item, it will be measured by the sq. yd. When vegetation barrier is specified as a separate pay item, it will be measured by the sq. yd.

When mulch, plant bed preparation, and vegetation barrier are specified as separate pay items and measured by the square yard, they are plans quantity measurement Items. The quantity to be paid is the quantity shown in the proposal, unless modified by Article 9.2., "Plans Quantity Measurement." Additional measurements or calculations will be made if adjustments of quantities are required.

5. PAYMENT

The work performed and materials furnished in accordance with this Item and measured as provided under "Measurement" will be paid for at the unit price bid for "Plant Material" of the size or "Plant Material" of the size and type specified. This price is full compensation for furnishing the plant, mulch, plant soil mix, landscape edge, plant bed preparation, and vegetation barrier, unless mulch, plant soil mix, landscape edge, plant bed preparation, and vegetation barrier are specified as separate items. Payment for "Plant Material" will be handled in the following manner:

- 5.1. **Initial Payment.** When the planting and installation of related materials are completed and approved, 55% of the unit price bid for each related plant will be paid.
- 5.2. **30-Day Payment.** When the first 30 days of the plant maintenance (see Section 192.3.15., "Maintenance,") are completed and approved, an additional 15% of the unit price bid for each related plant will be paid, but if the maintenance is not completed and approved, that 15% will be forfeited.
- 5.3. **60-Day Payment.** When the second 30 days of the plant maintenance are completed and approved, an additional 15% of the unit price bid for each related plant will be paid, but if the maintenance is not completed and approved, that 15% will be forfeited.
- 5.4. **Final Payment.** After the final inspection and acceptance of the project or the completion of the 90-day maintenance, whichever occurs later, an additional 15% of the unit price bid for all plants will be paid, but if the maintenance is not completed and approved, that 15% will be forfeited.

When mulch, plant soil mix, landscape edge, plant bed preparation, and vegetation barrier are specified as separate pay items, the work performed and materials furnished in accordance with this Item and measured as provided under "Measurement" will be paid for at the unit price bid for "Mulch" or "Mulch" of the type specified, "Plant Soil Mix" or "Plant Soil Mix" of the type specified, "Landscape Edge" or "Landscape Edge" of the type specified, "Plant Bed Preparation" or "Plant Bed Preparation" of the type specified, and "Vegetation Barrier" or "Vegetation Barrier" of the type specified." Each price is full compensation for materials, equipment, labor, tools, and incidentals.

Item 193

Landscape Establishment



1. DESCRIPTION

Establish landscape plantings and maintain landscaped areas at designated locations. Begin this Item after the final payment is approved in accordance with Section 192.5.4., "Final Payment," if used with Item 192, "Landscape Planting."

2. MATERIALS

Furnish the following materials unless otherwise shown on the plans:

- fertilizer in accordance with Article 166.2., "Materials;"
- mulch consisting of loose organic materials such as wood chips or shredded bark that is free from harmful chemicals, soil, and other foreign matter that may promote compaction of the mulch or cause injury to the plants;
- water that is clean and free of industrial wastes and other substances harmful to the growth of vegetation;
- replacement plants as originally installed or as approved;
- pesticides conforming to the requirements of Section 193.3.1., "Plant Maintenance;"
- supports of the same type as originally installed or as approved; and
- irrigation system replacement parts of the same type and manufacturer as originally installed or approved equal.

3. WORK METHODS

Inspect the site at least every 2 weeks, and perform the required maintenance when "Plant Maintenance" or "Irrigation System Operation and Maintenance" are measured by the month. Perform the following maintenance activities, and conform to requirements shown on the plans.

- 3.1. **Plant Maintenance.** Maintain vegetation within the site in a healthy and vigorous growing condition. Apply pesticides, when required, under the supervision of a person possessing a license in the appropriate use category issued by the Texas Department of Agriculture. Provide documentation of this license, and obtain approval of the pesticides before applications. Ensure pesticide applications conform to label directions and all pertinent laws and regulations.
- 3.1.1. **Pruning.** Prune in accordance with ANSI A300 (Part 1) when shown on the plans. Remove dead or dying plants and dead, diseased, or damaged limbs on trees and shrubs. Remove sucker-growth on trunks of trees. Apply an approved wound dressing to all oak (*Quercus*) species within 20 min. of causing bark damage or making a pruning cut. Remove and dispose of pruning debris.
- 3.1.2. **Insect, Disease, and Animal Control.** Notify the Engineer in writing of problems with insects, diseases, or animals as such problems arise. Treat the plants or planted areas as directed.
- 3.1.3. **Fertilization.** Apply fertilizer uniformly to all plants designated to receive fertilizer.
- 3.1.4. **Mulching, Plant Basin, and Plant Bed Maintenance.** Physically remove or apply herbicide to weeds and grasses within plant basins and plant beds before placing additional mulch. Apply and maintain mulch at a depth of 2 in. Maintain plant basins and plant beds free of weeds and grasses, except those that have been

treated with herbicides may remain in place until removal is directed. Reshape plant basins and plant beds as necessary to conform to plan details.

- 3.1.5. **Mowing, Trimming, and Edging.** Remove and dispose of litter within the designated areas before mowing. Mow and trim grassed areas at the designated height and frequency. Edge where required. Do not use nylon cord trimmers inside plant basins or inside beds containing plant material. Trim vegetation and remove debris from curbs, sidewalks, and other hardscape features.
- 3.1.6. **Staking, Guying, and Bracing of Plants.** Stake, guy, or brace plants as directed. Remove support materials when directed, and dispose of removed materials.
- 3.2. **Plant Replacement.** Remove plants selected by the Engineer and replace with plants of the original species, size, and characteristics or with approved substitutes, if required on the plans. Replace plants that have been damaged or killed due to the actions or negligence of the Contractor at no additional cost to the Department. Replace plants within the next scheduled work period following notification to begin replacement unless otherwise directed. Backfill in conformance with the plans or as directed.
- 3.3. **Vegetative Watering.** Apply water at the designated rate and frequency to plants or planting areas not serviced by an existing irrigation system. Apply water as directed, adjusting rate and frequency to provide adequate moisture to plant material. Use watering equipment with accurate measuring devices.
- 3.4. **Irrigation System Operation and Maintenance.** Maintain the system under the supervision of a person possessing an irrigator's license issued by the TCEQ, and provide documentation of this license. Verify and adhere to all local, state, and federal regulations. Coordinate and obtain required backflow preventer testing at no cost to the Department. Operate the system using water provided by the Department unless otherwise shown on the plans. Ensure that all zones are functioning properly and providing adequate moisture to plant material using an approved watering schedule. Winterize the system, when required, to prevent freeze damage in locations where temperatures fall below 32°F. Repair the system using replacement parts of the same type and manufacturer as originally installed or an approved equal. Provide plant irrigation by an approved alternate method at no cost to the Department if the system fails due to the Contractor's actions or neglect.

4. MEASUREMENT

"Plant Maintenance" will be measured by the month or by the cycle. "Plant Replacement" will be measured by each plant. "Vegetative Watering" will be measured by the 1,000 gal. of water. "Irrigation System Operation and Maintenance" will be measured by the month.

5. PAYMENT

The work performed and materials furnished in accordance with this Item and measured as provided under "Measurement" will be paid for at the unit price bid for "Plant Maintenance," "Plant Replacement" of the size specified, "Plant Replacement" of the size and type specified, "Plant Replacement" of the group specified, "Vegetative Watering," and "Irrigation System Operation and Maintenance." This price is full compensation for furnishing and operating equipment and for litter pickup, mowing, trimming, edging, pruning, fertilizer, labor, materials, tools, and incidentals. Plant replacement needed due to Contractor negligence will be at no additional cost to the Department.

200 Items

Subgrade Treatments and Base

This page intentionally left blank

Item 204

Sprinkling



1. DESCRIPTION

Apply water for dust control, earthwork, or base construction.

2. MATERIALS

Furnish water free of industrial wastes and other objectionable matter.

3. EQUIPMENT

Use sprinklers and spray bars equipped with positive and rapidly working cut-off valves.

4. CONSTRUCTION

Apply water at a uniform rate and in the required quantity, or as directed.

5. MEASUREMENT

This Item will be measured by the 1,000 gal. applied.

6. PAYMENT

Unless sprinkling is specified as a pay item, the work performed and materials furnished in accordance with this Item will not be paid for directly but will be subsidiary to pertinent Items.

When sprinkling is specified on the plans as a pay item, the work performed and water furnished will be paid for at the unit price bid for "Sprinkling (Base)," "Sprinkling (Earthwork)," or "Sprinkling (Dust Control)." This price is full compensation for furnishing and applying water; furnishing and operating sprinklers and measuring devices; and hauling, equipment, labor, fuel, materials, tools, and incidentals.

Item 210

Rolling



1. DESCRIPTION

Compact embankment, subgrade, base, surface treatments, broken concrete pavement, or asphalt pavement using rollers. Break up asphalt mats, pit run material, or base materials.

2. EQUIPMENT

Use any type of roller to meet the production rates and quality requirements of the Contract unless otherwise shown on the plans or directed. Use equipment that meets the requirements of this Item when specific types of equipment are required. The Engineer may allow the use of rollers that operate in one direction only when turning does not affect the quality of work or encroach on traffic.

Table 1
Roller Requirements¹

Roller Type	Materials to be Compacted	Load (tons)	Contact Pressure	Roller Speed (mph)
Steel wheel	Embankment, subgrade, base, asphalt concrete	≥ 10	≥ 325 lb. per inch of wheel width	2–3
Tamping	Embankment, subgrade	–	125–550 psi per tamping foot	2–3
Heavy tamping	Embankment, subgrade	–	≥ 550 psi per tamping foot	2–3
Vibratory	Embankment, subgrade, base, asphalt concrete	Type A < 6 Type B > 6 Type C as shown on the plans	Per equipment specification and as approved	As approved
Light pneumatic	Embankment, subgrade, surface treatment	4.5–9.0	≥ 45 psi	2–6
	Asphalt Concrete			4–12
Medium pneumatic	Embankment, subgrade, base, surface treatment	12–25	≥ 80 psi, as directed	2–6
	Asphalt Concrete			4–12
Heavy pneumatic	Embankment, subgrade, base, previously broken concrete pavement, other pavements	≥ 25	≤ 150 psi	2–6
Grid	Embankment, breaking up existing asphalt mats or base	5–13	–	2–3

1. Unless otherwise specified in the Contract.

- 2.1. **Static Steel Wheel Rollers.** Furnish single, double, or triple steel wheel, self-propelled power rollers weighing at least 10 tons capable of operating in a forward and backward motion. Ensure all wheels are flat. The Contractor may use vibratory rollers in the static mode when static steel wheel rollers are required.

For single steel wheel rollers, pneumatic rear wheels are allowed for embankment, subgrade, and base. Provide rear wheels for triple steel wheel rollers with a minimum diameter of 48 in., a minimum width of 20 in., and a minimum compression of 325 lb. per inch of wheel width.

- 2.2. **Tamping Rollers.** Furnish self-propelled rollers with at least one self-cleaning metal tamping drum capable of operating in a forward or backward motion with a minimum effective rolling width of 5 ft. Mount drums in a frame so that each drum moves independently of the other for rollers with more than one drum. Operate rollers in static or vibratory mode.

- 2.2.1. **Tamping Roller (Minimum Requirement).** Provide tamping feet that exert a static load of 125 to 550 psi and project at least 3 in. from the surface of the drum for all tamping rollers except for heavy tamping rollers.

- 2.2.2. **Heavy Tamping Roller.** Provide tamping rollers that have:

- 2 metal tamping drums, rolls, or shells, each with a 60-in. minimum diameter and a 5-ft. minimum width, or
- 1 rear and 2 forward drums, each with a 60-in. minimum diameter. Arrange drums so that the rear drum compacts the space between the 2 forward drums and the minimum overall rolling width is 10 ft.

Equip drums with tamping feet that:

- project at least 7 in. from the drum surface,
- have an area of 7 to 21 sq. in.,
- are self-cleaning,
- exert a static load of at least 550 psi, and
- are spaced at 1 tamping foot per 0.65 to 0.70 square feet of drum area.

- 2.3. **Vibratory Rollers.** Furnish self-propelled rollers with at least one drum equipped to vibrate. Select and maintain amplitude and frequency settings per manufacturer's specifications to deliver maximum compaction without material displacement or shoving, as approved. Furnish the equipment manufacturer's specifications concerning settings and controls for amplitude and frequency. Operate rollers at speeds that will produce at least 10 blows per foot unless otherwise shown on the plans or approved. Pneumatic rear wheels are allowed for embankment, subgrade, and base. Equip each vibrating drum with:

- separate frequency and amplitude controls,
- controls to manually start and stop vibration, and
- a mechanism to continuously clean the face of the drum.

For asphalt-stabilized base and asphalt concrete pavement, furnish a roller that also has the ability to:

- automatically reverse the direction of the rotating eccentric weight,
- stop vibration before the motion of the roller stops, and
- thoroughly moisten the drum with water or approved asphalt release agent.

- 2.3.1. **Drum (Type A).** Furnish a roller with a static weight less than 6 tons and a vibratory drum.

- 2.3.2. **Drum (Type B).** Furnish a roller with a minimum static weight of 6 tons and a vibratory drum.

- 2.3.3. **Drum (Type C).** Furnish a roller as shown on the plans.

- 2.4. **Pneumatic Tire Rollers.** Pneumatic tire rollers consist of rubber tire wheels on axles mounted in a frame with either a loading platform or body suitable for ballast loading. Arrange the rear tires to cover the gaps between adjacent tires of the forward group. Furnish rollers capable of forward and backward motion.

Compact asphalt pavements and surface treatments with a roller equipped with smooth-tread tires. Compact without damaging the surface. Moisten the wheels with water or an approved asphalt release agent when necessary.

Select and maintain the operating load and tire air pressure within the range of the manufacturer's charts or tabulations to attain maximum compaction throughout the lift, as approved. Furnish the manufacturer's chart or tabulations showing the contact areas and contact pressures for the full range of tire inflation pressures and for the full range of loadings for the particular tires furnished. Maintain individual tire inflation pressures within 5 psi of each other. Provide uniform compression under all tires.

2.4.1. **Light Pneumatic Tire.** Furnish a unit:

- with at least 9 pneumatic tires,
- with an effective rolling width of approximately 5 ft.,
- capable of providing a total uniform load of 4.5 to 9 tons, and
- with tires capable of maintaining a minimum ground contact pressure of 45 psi.

2.4.2. **Medium Pneumatic Tire.** Furnish a unit:

- with at least 7 pneumatic tires,
- with an effective rolling width of approximately 7 ft.,
- capable of providing a total uniform load of 12 to 25 tons, and
- with tires capable of maintaining a minimum ground contact pressure of 80 psi or 90 psi as directed.

2.4.3. **Heavy Pneumatic Tire.** Furnish a unit:

- with at least 4 pneumatic-tired wheels mounted on axles carrying no more than 2 wheels,
- with wheels arranged to carry approximately equal loads on uneven surfaces,
- with a width between 8 and 10 ft. that can turn 180° in the crown width,
- capable of providing a total uniform load of at least 25 tons,
- with tires capable of maintaining a maximum ground contact pressure of 150 psi, and
- with liquid-filled tires inflated to such a level that liquid will flow from the valve stem when the stem is in the uppermost position.

2.5. **Grid Rollers.** Furnish rollers that have 2 cylindrical cages with a minimum diameter of 66 in. and a minimum width of 32 in. Mount cages in a rigid frame with weight boxes. Use a cage surface of cast or welded steel fabric grid with bars 1-1/2 in. wide, spaced on 5-in. centers in each direction, that undulate approximately 1 in. between the high and low points.

Furnish rollers capable of providing a total load of 5 to 13 tons and capable of being operated in a forward or backward motion.

2.6. **Alternate Equipment.** The Contractor may use alternate compaction equipment that produces results equivalent to the specified equipment as approved. Discontinue the use of the alternate equipment and furnish the specified equipment if the desired results are not achieved.

3. CONSTRUCTION

Perform this work in accordance with the applicable Items using equipment and roller speeds specified in Table 1. Use only rubber-tired equipment to push or pull compaction equipment on base courses. Use equipment that does not damage material being rolled.

4. MEASUREMENT AND PAYMENT

The work performed, materials furnished, equipment, labor, tools, and incidentals will not be measured or paid for directly but will be subsidiary to pertinent Items.

Item 216

Proof Rolling



1. DESCRIPTION

Proof-roll earthwork, base, or both to locate unstable areas.

2. EQUIPMENT

- 2.1. **Specified Equipment.** Furnish rollers that weigh at least 25 tons when loaded. The maximum acceptable load is 50 tons. Provide rollers that meet the requirements of Section 210.2.4., "Pneumatic Tire Rollers."
- 2.2. **Alternative Equipment.** The Contractor may use alternate compaction equipment that produces results equivalent to the specified equipment in the same period of time as approved. Discontinue the use of the alternative equipment and furnish the specified equipment if the desired results are not achieved.

3. CONSTRUCTION

Perform proof rolling as directed. Adjust the load and tire inflation pressures within the range of the manufacturer's charts or tabulations, as directed. Make at least 2 coverages with the proof roller. Offset each trip of the roller by at most one tire width. Operate rollers at a speed between 2 and 6 mph, as directed. Correct unstable or nonuniform areas, if found, in accordance with the applicable Item.

4. MEASUREMENT

Rolling will be measured by the hour operated on surfaces being tested.

5. PAYMENT

The work performed and equipment furnished in accordance with this Item and measured as provided under "Measurement" will be paid for at the unit price bid for "Proof Rolling." This price is full compensation for furnishing and operating equipment and for labor, materials, tools, and incidentals.

Item 247

Flexible Base



1. DESCRIPTION

Construct a foundation course composed of flexible base.

2. MATERIALS

Furnish uncontaminated materials of uniform quality that meet the requirements of the plans and specifications. Notify the Engineer of the proposed material sources and of changes to material sources. The Engineer may sample and test project materials at any time before compaction throughout the duration of the project to assure specification compliance. Use Tex-100-E material definitions.

- 2.1. **Aggregate.** Furnish aggregate of the type and grade shown on the plans and meeting the requirements of Table 1. Each source must meet Table 1 requirements for liquid limit, plasticity index, and wet ball mill for the grade specified. Do not use additives, such as but not limited to lime, cement, or fly ash to modify aggregates to meet the requirements of Table 1 unless shown on the plans.

Table 1
Material Requirements

Property	Test Method	Grade 1-2	Grade 3	Grade 4 ²	Grade 5
Sampling	Tex-400-A				
Master gradation sieve size (cumulative % retained)	Tex-110-E			As shown on the plans	
2-1/2"		0	0		0
1-3/4"		0-10	0-10		0-5
7/8"		10-35	-		10-35
3/8"		30-65	-		35-65
#4		45-75	45-75		45-75
#40	65-90	50-85	70-90		
Liquid Limit, % Max	Tex-104-E	40	40	As shown on the plans	35
Plasticity Index, Max ¹	Tex-106-E	10	12	As shown on the plans	10
Plasticity index, Min ¹		As shown on the plans	As shown on the plans	As shown on the plans	As shown on the plans
Wet ball mill, % Max	Tex-116-E	40	-	As shown on the plans	40
Wet ball mill, % Max increase passing the #40 sieve		20	-	As shown on the plans	20
Min compressive strength, psi	Tex-117-E			As shown on the plans	
lateral pressure 0 psi		35	-		-
lateral pressure 3 psi		-	-		90
lateral pressure 15 psi		175	-		175

- Determine plastic index in accordance with Tex-107-E (linear shrinkage) when liquid limit is unattainable as defined in Tex-104-E.
- Grade 4 may be further designated as Grade 4A, Grade 4B, etc.

- 2.1.1. **Material Tolerances.** The Engineer may accept material if no more than 1 of the 5 most recent gradation tests has an individual sieve outside the specified limits of the gradation.

When target grading is required by the plans, no single failing test may exceed the master grading by more than 5 percentage points on sieves No. 4 and larger or 3 percentage points on sieves smaller than No. 4.

The Engineer may accept material if no more than 1 of the 5 most recent plasticity index tests is outside the specified limit. No single failing test may exceed the allowable limit by more than 2 points.

- 2.1.2. **Material Types.** Do not use fillers or binders unless approved. Furnish the type specified on the plans in accordance with the following:
- 2.1.2.1. **Type A.** Crushed stone produced and graded from oversize quarried aggregate that originates from a single, naturally occurring source. Do not use gravel or multiple sources.
- 2.1.2.2. **Type B.** Crushed or uncrushed gravel. Blending of 2 or more sources is allowed.
- 2.1.2.3. **Type C.** Crushed gravel with a minimum of 60% of the particles retained on a No. 4 sieve with 2 or more crushed faces as determined by Tex-460-A, Part I. Blending of 2 or more sources is allowed.
- 2.1.2.4. **Type D.** Type A material or crushed concrete. Crushed concrete containing gravel will be considered Type D material. Crushed concrete must meet the requirements in Section 247.2.1.3.2., "Recycled Material (Including Crushed Concrete) Requirements," and be managed in a way to provide for uniform quality. The Engineer may require separate dedicated stockpiles in order to verify compliance.
- 2.1.2.5. **Type E.** Caliche, iron ore or as otherwise shown on the plans.
- 2.1.3. **Recycled Material.** Reclaimed asphalt pavement (RAP) and other recycled materials may be used when shown on the plans. Request approval to blend 2 or more sources of recycled materials.
- 2.1.3.1. **Limits on Percentage.** Do not exceed 20% RAP by weight, when RAP is allowed, unless otherwise shown on the plans. The percentage limitations for other recycled materials will be as shown on the plans.
- 2.1.3.2. **Recycled Material (Including Crushed Concrete) Requirements.**
- 2.1.3.2.1. **Contractor-Furnished Recycled Materials.** Provide recycled materials, other than RAP, that have a maximum sulfate content of 3,000 ppm when tested in accordance with Tex-145-E. When the Contractor furnishes the recycled materials, including crushed concrete, the final product will be subject to the requirements of Table 1 for the grade specified. Certify compliance with DMS-11000, "Evaluating and Using Nonhazardous Recyclable Materials Guidelines," for Contractor furnished recycled materials. In addition, recycled materials must be free from reinforcing steel and other objectionable material and have at most 1.5% deleterious material when tested in accordance with Tex-413-A. For RAP, do not exceed a maximum percent loss from decantation of 5.0% when tested in accordance with Tex-406-A. Test RAP without removing the asphalt.
- 2.1.3.2.2. **Department-Furnished Required Recycled Materials.** When the Department furnishes and requires the use of recycled materials, unless otherwise shown on the plans:
- Department-required recycled material will not be subject to the requirements in Table 1,
 - Contractor-furnished materials are subject to the requirements in Table 1 and this Item,
 - the final product, blended, will be subject to the requirements in Table 1, and
 - for final product, unblended (100% Department-furnished required recycled material), the liquid limit, plasticity index, wet ball mill, and compressive strength is waived.
- Crush Department-furnished RAP so that 100% passes the 2 in. sieve. The Contractor is responsible for uniformly blending to meet the percentage required.
- 2.1.3.2.3. **Department-Furnished and Allowed Recycled Materials.** When the Department furnishes and allows the use of recycled materials or allows the Contractor to furnish recycled materials, the final blended product is subject to the requirements of Table 1 and the plans.

- 2.1.3.3. **Recycled Material Sources.** Department-owned recycled material is available to the Contractor only when shown on the plans. Return unused Department-owned recycled materials to the Department stockpile location designated by the Engineer unless otherwise shown on the plans.

The use of Contractor-owned recycled materials is allowed when shown on the plans. Contractor-owned surplus recycled materials remain the property of the Contractor. Remove Contractor-owned recycled materials from the project and dispose of them in accordance with federal, state, and local regulations before project acceptance. Do not intermingle Contractor-owned recycled material with Department-owned recycled material unless approved.

- 2.2. **Water.** Furnish water free of industrial wastes and other objectionable matter.
- 2.3. **Material Sources.** Expose the vertical faces of all strata of material proposed for use when non-commercial sources are used. Secure and process the material by successive vertical cuts extending through all exposed strata, when directed.

3. EQUIPMENT

Provide machinery, tools, and equipment necessary for proper execution of the work.

- 3.1. Provide rollers in accordance with Item 210, "Rolling." Provide proof rollers in accordance with Item 216, "Proof Rolling," when required.
- 3.2. When ride quality measurement is required, provide a high speed or lightweight inertial profiler certified at the Texas A&M Transportation Institute. Provide equipment certification documentation. Display a current decal on the equipment indicating the certification expiration date.

4. CONSTRUCTION

Construct each layer uniformly, free of loose or segregated areas, and with the required density and moisture content. Provide a smooth surface that conforms to the typical sections, lines, and grades shown on the plans or as directed.

Stockpile base material temporarily at an approved location before delivery to the roadway. Build stockpiles in layers no greater than 2 ft. thick. Stockpiles must have a total height between 10 and 16 ft. unless otherwise approved. After construction and acceptance of the stockpile, loading from the stockpile for delivery is allowed. Load by making successive vertical cuts through the entire depth of the stockpile.

Do not add or remove material from temporary stockpiles that require sampling and testing before delivery unless otherwise approved. Charges for additional sampling and testing required as a result of adding or removing material will be deducted from the Contractor's estimates.

Haul approved flexible base in clean trucks. Deliver the required quantity to each 100-ft. station or designated stockpile site as shown on the plans. Prepare stockpile sites as directed. When delivery is to the 100-ft. station, manipulate in accordance with the applicable Items.

- 4.1. **Preparation of Subgrade or Existing Base.** Remove or scarify existing asphalt concrete pavement in accordance with Item 105, "Removing Treated and Untreated Base and Asphalt Pavement," when shown on the plans or as directed. Shape the subgrade or existing base to conform to the typical sections shown on the plans or as directed.

When new base is required to be mixed with existing base, deliver, place, and spread the new flexible base in the required amount per station. Manipulate and thoroughly mix the new base with existing material to provide a uniform mixture to the specified depth before shaping.

Proof roll the roadbed in accordance with Item 216, "Proof Rolling," before pulverizing or scarifying when shown on the plans or directed. Correct soft spots as directed.

- 4.2. **Placing.** Spread and shape flexible base into a uniform layer with an approved spreader the same day as delivered unless otherwise approved. Construct layers to the thickness shown on the plans. Maintain the shape of the course. Control dust by sprinkling, as directed. Correct or replace segregated areas as directed, at no additional expense to the Department.

Place successive base courses and finish courses using the same construction methods required for the first course.

- 4.3. **Compaction.** Compact using density control unless otherwise shown on the plans. Multiple lifts are permitted when shown on the plans or approved. Bring each layer to the moisture content directed. When necessary, sprinkle the material in accordance with Item 204, "Sprinkling."

Begin rolling longitudinally at the sides and proceed towards the center, overlapping on successive trips by at least 1/2 the width of the roller unit. Begin rolling at the low side and progress toward the high side on superelevated curves. Offset alternate trips of the roller. Operate rollers at a speed between 2 and 6 mph as directed.

Rework, recompact, and refinish material that fails to meet or that loses required moisture, density, stability, or finish requirements before the next course is placed or the project is accepted. Continue work until specification requirements are met. Perform the work at no additional expense to the Department.

Before final acceptance, the Engineer will select the locations of tests and measure the flexible base depth in accordance with Tex-140-E. Correct areas deficient by more than 1/2 in. in thickness by scarifying, adding material as required, reshaping, recompacting, and refinishing at the Contractor's expense.

- 4.3.1. **Ordinary Compaction.** Roll with approved compaction equipment as directed. Correct irregularities, depressions, and weak spots immediately by scarifying the areas affected, adding or removing approved material as required, reshaping, and recompacting.

- 4.3.2. **Density Control.** Compact to at least 100% of the maximum dry density determined by Tex-113-E, unless otherwise shown on the plans. Maintain moisture during compaction within ± 2 percentage points of the optimum moisture content as determined by Tex-113-E. Measure the moisture content of the material in accordance with Tex-115-E or Tex-103-E during compaction daily and report the results the same day to the Engineer, unless otherwise shown on the plans or directed. Do not achieve density by drying the material after compaction.

The Engineer will determine roadway density and moisture content of completed sections in accordance with Tex-115-E. The Engineer may accept the section if no more than 1 of the 5 most recent density tests is below the specified density and the failing test is no more than 3 pcf below the specified density.

- 4.4. **Finishing.** After completing compaction, clip, skin, or tight-blade the surface with a maintainer or subgrade trimmer to a depth of approximately 1/4 in. Remove loosened material and dispose of it at an approved location. Seal the clipped surface immediately by rolling with a pneumatic tire roller until a smooth surface is attained. Add small increments of water as needed during rolling. Shape and maintain the course and surface in conformity with the typical sections, lines, and grades as shown on the plans or as directed.

Correct grade deviations greater than 1/4 in. in 16 feet measured longitudinally or greater than 1/4 in. over the entire width of the cross-section in areas where surfacing is to be placed. Correct by loosening and adding, or removing material. Reshape and re-compact in accordance with Section 247.4.3., "Compaction."

- 4.5. **Curing.** Cure the finished section until the moisture content is at least 2 percentage points below optimum or as directed before applying the next successive course or prime coat.

- 4.6. **Ride Quality.** This section applies to the final travel lanes that receive a 1 or 2 course surface treatment for the final surface, unless otherwise shown on the plans. Measure ride quality of the base course after placement of the prime coat and before placement of the surface treatment, unless otherwise approved. Use a certified profiler operator from the Department's MPL. When requested, furnish the Engineer documentation for the person certified to operate the profiler.

Provide all profile measurements to the Engineer in electronic data files within 3 days after placement of the prime coat using the format specified in Tex-1001-S. The Engineer will use Department software to evaluate longitudinal profiles to determine areas requiring corrective action. Correct 0.1-mi.sections having an average international roughness index (IRI) value greater than 100.0 in. per mile to an IRI value of 100.0 in. per mile or less for each wheel path, unless otherwise shown on the plans.

Re-profile and correct sections that fail to maintain ride quality until placement of the next course, as directed. Correct re-profiled sections until specification requirements are met, as approved. Perform this work at no additional expense to the Department.

5. MEASUREMENT

Flexible base will be measured as follows:

- **Flexible Base (Complete In Place).** The ton, square yard, or any cubic yard method.
- **Flexible Base (Roadway Delivery).** The ton or any cubic yard method.
- **Flexible Base (Stockpile Delivery).** The ton, cubic yard in vehicle, or cubic yard in stockpile.

Measurement by the cubic yard in final position and square yard is a plans quantity measurement. The quantity to be paid for is the quantity shown in the proposal unless modified by Article 9.2., "Plans Quantity Measurement." Additional measurements or calculations will be made if adjustments of quantities are required.

Measurement is further defined for payment as follows.

- 5.1. **Cubic Yard in Vehicle.** By the cubic yard in vehicles of uniform capacity at the point of delivery.
- 5.2. **Cubic Yard in Stockpile.** By the cubic yard in the final stockpile position by the method of average end areas.
- 5.3. **Cubic Yard in Final Position.** By the cubic yard in the completed and accepted final position. The volume of base course is computed in place by the method of average end areas between the original subgrade or existing base surfaces and the lines, grades, and slopes of the accepted base course as shown on the plans.
- 5.4. **Square Yard.** By the square yard of surface area in the completed and accepted final position. The surface area of the base course is based on the width of flexible base as shown on the plans.
- 5.5. **Ton.** By the ton of dry weight in vehicles as delivered. The dry weight is determined by deducting the weight of the moisture in the material at the time of weighing from the gross weight of the material. The Engineer will determine the moisture content in the material in accordance with Tex-103-E from samples taken at the time of weighing.

When material is measured in trucks, the weight of the material will be determined on certified scales, or the Contractor must provide a set of standard platform truck scales at a location approved by the Engineer. Scales must conform to the requirements of Item 520, "Weighing and Measuring Equipment."

6. PAYMENT

The work performed and materials furnished in accordance with this Item and measured as provided under "Measurement" will be paid for at the unit price bid for the types of work shown below. No additional payment

will be made for thickness or width exceeding that shown on the typical section or provided on the plans for cubic yard in the final position or square yard measurement.

Sprinkling and rolling, except proof rolling, will not be paid for directly but will be subsidiary to this Item unless otherwise shown on the plans. When proof rolling is shown on the plans or directed, it will be paid for in accordance with Item 216, "Proof Rolling."

Where subgrade is constructed under this Contract, correction of soft spots in the subgrade will be at the Contractor's expense. Where subgrade is not constructed under this Contract, correction of soft spots in the subgrade will be paid in accordance with pertinent Items or Article 4.4., "Changes in the Work."

- 6.1. **Flexible Base (Complete In Place).** Payment will be made for the type and grade specified. For cubic yard measurement, "In Vehicle," "In Stockpile," or "In Final Position" will be specified. For square yard measurement, a depth will be specified. This price is full compensation for furnishing materials, temporary stockpiling, assistance provided in stockpile sampling and operations to level stockpiles for measurement, loading, hauling, delivery of materials, spreading, blading, mixing, shaping, placing, compacting, reworking, finishing, correcting locations where thickness is deficient, curing, furnishing scales and labor for weighing and measuring, and equipment, labor, tools, and incidentals.
- 6.2. **Flexible Base (Roadway Delivery).** Payment will be made for the type and grade specified. For cubic yard measurement, "In Vehicle," "In Stockpile," or "In Final Position" will be specified. The unit price bid will not include processing at the roadway. This price is full compensation for furnishing materials, temporary stockpiling, assistance provided in stockpile sampling and operations to level stockpiles for measurement, loading, hauling, delivery of materials, furnishing scales and labor for weighing and measuring, and equipment, labor, tools, and incidentals.
- 6.3. **Flexible Base (Stockpile Delivery).** Payment will be made for the type and grade specified. For cubic yard measurement, "In Vehicle" or "In Stockpile" will be specified. The unit price bid will not include processing at the roadway. This price is full compensation for furnishing and disposing of materials, preparing the stockpile area, temporary or permanent stockpiling, assistance provided in stockpile sampling and operations to level stockpiles for measurement, loading, hauling, delivery of materials to the stockpile, furnishing scales and labor for weighing and measuring, and equipment, labor, tools, and incidentals.

Item 251

Reworking Base Courses



1. DESCRIPTION

Refinish or rework existing base material with or without asphaltic concrete pavement. Incorporate new base material when shown on the plans.

2. MATERIALS

Furnish uncontaminated materials of uniform quality that meet the requirements of the plans and specifications. Notify the Engineer of the proposed material sources and of changes to material sources. The Engineer will verify that the specification requirements are met before the sources can be used. The Engineer may sample and test project materials at any time before compaction. Use Tex-100-E for material definitions.

2.1. **Flexible Base.** Furnish new base material that meets the requirements of Item 247, "Flexible Base," for the type and grade shown on the plans.

2.2. **Water.** Furnish water free of industrial wastes and other objectionable matter.

3. EQUIPMENT

Provide machinery, tools, and equipment necessary for proper execution of the work.

3.1. **Compaction Equipment.** Provide rollers in accordance with Item 210, "Rolling." Provide rollers in accordance with Item 216, "Proof Rolling," when required.

3.2. **Pulverization Equipment.** Provide pulverization equipment that:

- cuts and pulverizes material uniformly to the proper depth with cutters that plane to a uniform surface over the entire width of the cut,
- provides a visible indication of the depth of cut at all times, and
- uniformly mixes the materials.

4. CONSTRUCTION

Perform work to the width and depth shown on the typical sections for the type of work shown on the plans. Construct and shape exposed subgrade to conform to typical sections as shown on the plans or as directed. Proof roll in accordance with Item 216, "Proof Rolling," when shown on the plans. Correct soft spots as directed.

Before scarifying, clean the existing base of objectionable materials by blading, brooming, or other approved methods, unless otherwise shown on the plans. Perform this work in accordance with applicable Items.

4.1. **Types of Work.**

4.1.1. **Type A.** Scarifying only.

4.1.2. **Type B.** Scarifying, salvaging, and re-laying.

- 4.1.3. **Type C.** Scarifying and reshaping.
- 4.1.4. **Type D.** Refinishing.
- 4.2. **Performance of Work.**
- 4.2.1. **Scarifying.** Loosen and break existing base material, with or without existing asphaltic concrete pavement. Remove asphalt concrete pavement, surface treatment, plant-mix seal, and micro-surfacing when shown on the plans and in accordance with applicable items. Prevent contamination of asphalt material during and after removal. When the existing pavement consists of only a surface treatment, do not remove before scarifying. Scarify existing material for its full width and depth unless otherwise shown on the plans. Do not disturb the underlying subgrade. Break material into particles of not more than 2-1/2 in. unless otherwise shown on the plans.
- 4.2.2. **Salvaging.** Remove the existing base material and stockpile. Windrow if allowed. Perform salvage operations without interfering with traffic, proper drainage, or the general requirements of the work. Remove scarified material using a method approved by the Engineer. Keep material free of contamination.
- 4.2.3. **Re-Laying.** Prepare subgrade as shown on the plans or as directed before relaying salvaged material. Proof roll in accordance with Item 216, "Proof Rolling," when shown on the plans. Correct soft spots as directed.
- Return and rework salvaged base material, with or without additional new base material, on the prepared roadbed. Place salvaged material on the prepared subgrade and sprinkle, blade, and shape the base to conform to the typical sections shown on the plans or as directed. Place new base material and uniformly mix with salvaged material when shown on the plans. Correct, or remove and replace, segregated material with satisfactory material, as directed.
- 4.2.4. **Reshaping.** Rework scarified base material with or without additional new base material. Mix and shape scarified base to conform to the typical sections shown on the plans. When shown on the plans, furnish new base material, and uniformly mix with scarified material before shaping. Do not disturb the underlying subgrade. Correct, or remove and replace, segregated material with satisfactory material as directed.
- 4.2.5. **Refinishing.** Blade existing base surface to remove irregularities. Cure before placing the pavement on the refinished base, as shown on the plans or as directed.
- 4.3. **Compaction.** Compact using ordinary compaction or density control as shown on the plans. Bring each layer to the moisture content directed. When necessary, sprinkle the material in accordance with Item 204, "Sprinkling."
- Begin rolling longitudinally at the sides and proceed toward the center, overlapping on successive trips by at least one-half the width of the roller unit. On superelevated curves, begin rolling at the low side and progress toward the high side. Offset alternate trips of the roller. Operate rollers at a speed between 2 and 6 mph, as directed.
- Rework, recompact, and refinish material that fails to meet or that loses required moisture, density, stability, or finish before the next course is placed or the project is accepted. Continue work until specification requirements are met. Perform the work at no additional expense to the Department.
- 4.3.1. **Ordinary Compaction.** Roll with approved compaction equipment as directed. Correct irregularities, depressions, and weak spots immediately by scarifying the areas affected, adding or removing approved material as required, reshaping, and recompacting.
- 4.3.2. **Density Control.** Determine the moisture content in the mixture at the beginning of and during compaction in accordance with Tex-103-E. Compact to at least 98% of the maximum density determined by Tex-113-E, unless otherwise shown on the plans.

The Engineer will determine roadway density of completed sections in accordance with Tex-115-E. The Engineer may accept the section if no more than 1 of the 5 most recent density tests is below the specified density and the failing test is no more than 3 pcf below the specified density.

- 4.4. **Finishing.** Immediately after completing compaction, clip, skin, or tight-blade the surface with a maintainer or subgrade trimmer to a depth of approximately 1/4 in. Remove and dispose of loosened material at an approved location. Seal the clipped surface immediately by rolling with a pneumatic tire roller until a smooth surface is attained. Add small amounts of water as needed during rolling. Shape and maintain the course and surface in conformity with the typical sections, lines, and grades shown on the plans or as directed.

In areas where surfacing is to be placed, correct grade deviations in excess of 1/4 in. in 16 ft. measured longitudinally for the entire width of the cross-section. Correct by loosening, adding, or removing material. Reshape and recompact in accordance with Section 251.4.3., "Compaction."

- 4.5. **Curing.** Cure the finished section until the moisture content is at least 2% below optimum or as directed before applying the next successive course or prime coat.

5. MEASUREMENT

This Item will be measured by the station, square yard, cubic yard, or ton.

Square yard and cubic yard in original position measurement will be established by the widths and depths shown on the plans and the lengths measured in the field.

When material is measured in trucks, the weight of the material will be determined on certified scales, or the Contractor must provide a set of standard platform truck scales at a location approved by the Engineer. Scales must conform to the requirements of Item 520, "Weighing and Measuring Equipment."

Measurement is further defined for payment as follows.

- 5.1. **Station.** By the 100-ft. station measured along the centerline of each roadbed.
- 5.2. **Square Yard.** By the square yard of existing base or pavement in its original position. When square yard measurement is used, limits of measurement will be as shown on the plans.
- 5.3. **Cubic Yard in Vehicle.** By the cubic yard of salvaged material in vehicles as delivered at the stockpile.
- 5.4. **Cubic Yard in Stockpile.** By the cubic yard of salvaged material in the final stockpile position by the method of average end areas.
- 5.5. **Cubic Yard in Original Position.** By the cubic yard in its original position measured by the method of average end areas.
- 5.6. **Ton.** By the ton of dry weight in the trucks as delivered at the stockpile. The dry weight is determined by deducting the weight of the moisture in the material at the time of weighing from the gross weight of the material. The Engineer will determine the moisture content in the material in accordance with Tex-103-E from samples taken at the time of truck weighing.

6. PAYMENT

The work performed and materials furnished in accordance with this Item and measured as provided under "Measurement" will be paid for at the unit price bid for "Reworking Base Material" for the type, scarified depth, and compaction method shown on the plans. For cubic yard measurements, the measurement location (vehicle, stockpile, or original position) will be specified. No additional payment will be made for thickness or width exceeding that shown on the typical sections or provided on the plans for station, square yard, and cubic yard in the original position measurement. This price is full compensation for furnishing and

disposing of materials, blading, brooming, scarifying, salvaging, replacing, stockpiling, reshaping, refinishing, compacting, finishing, curing, and equipment, labor, tools, and incidentals.

Furnishing and delivering new base will be paid for in accordance with Section 247.6.2., "Flexible Base (Roadway Delivery)." Mixing, spreading, blading, shaping, compacting, and finishing new or existing base material will not be paid for directly but will be subsidiary to this Item.

Sprinkling and rolling, except proof rolling, will not be paid for directly but will be subsidiary to this Item, unless otherwise shown on the plans. When proof rolling is shown on the plans or directed by the Engineer, it will be paid for in accordance with Item 216, "Proof Rolling."

Where subgrade is constructed under this Contract, correction of soft spots in the subgrade or existing base will be at the Contractor's expense. Where subgrade is not constructed under this Contract, correction of soft spots in the subgrade or existing base will be in accordance with pertinent Items or Article 4.4., "Changes in the Work."

Removal of existing asphalt concrete pavement will be paid for in accordance with pertinent Items or Article 4.4., "Changes in the Work."

Additional restrictions for measurement and payment are as follows:

- **Type A.** Work will be restricted to station and square yard measurement.
- **Type B.** Work will be restricted to station, square yard, and cubic yard in the original position measurement.
- **Type C.** Work will be restricted to station, square yard, and cubic yard in the original position measurement.
- **Type D.** Work will be restricted to station and square yard measurement.

Item 260

Lime Treatment (Road-Mixed)



1. DESCRIPTION

Mix and compact lime, water, and subgrade or base (with or without asphaltic concrete pavement) in the roadway.

2. MATERIALS

Furnish uncontaminated materials of uniform quality that meet the requirements of the plans and specifications. Notify the Engineer of the proposed material sources and of changes to material sources. Obtain verification from the Engineer that the specification requirements are met before using the sources. The Engineer may sample and test project materials at any time before compaction. Use Tex-100-E for material definitions.

- 2.1. **Lime.** Furnish lime that meets the requirements of DMS-6350 "Lime and Lime Slurry," and DMS-6330, "Pre-Qualification of Lime Sources." Use hydrated lime, commercial lime slurry, quicklime, or carbide lime slurry as shown on the plans. Do not use quicklime when sulfates are present in quantities greater than 3,000 ppm. When furnishing quicklime, provide it in bulk.
- 2.2. **Subgrade.** The Engineer will determine the sulfate content of the existing subgrade in accordance with Tex-145-E and organic content in accordance with Tex-148-E before lime treatment begins. Suspend operations when material to be treated has a sulfate content greater than 7,000 ppm or an organic content greater than 1.0% and proceed as directed.
- 2.3. **Flexible Base.** Unless otherwise shown on the plans, furnish base material that meets the requirements of Item 247, "Flexible Base," for the type and grade shown on the plans, before the addition of lime.
- 2.4. **Water.** Furnish water free of industrial wastes and other objectionable material.
- 2.5. **Asphalt.** When asphalt or emulsion is permitted for curing purposes, furnish materials that meet the requirements of Item 300, "Asphalts, Oils, and Emulsions," as shown on the plans or as directed.
- 2.6. **Mix Design.** The Engineer will determine the target lime content and optimum moisture content in accordance with Tex-121-E or prior experience with the project materials. The Contractor may propose a mix design developed in accordance with Tex-121-E. The Engineer will use Tex-121-E to verify the Contractor's proposed mix design before acceptance. Reimburse the Department for subsequent mix designs or partial designs necessitated by changes in the material or requests by the Contractor. Limit the amount of recycled asphalt pavement to no more than 50% of the mix unless otherwise shown on the plans or directed.

3. EQUIPMENT

Provide machinery, tools, and equipment necessary for proper execution of the work. Provide rollers in accordance with Item 210, "Rolling." Provide proof rollers in accordance with Item 216, "Proof Rolling," when required.

- 3.1. **Storage Facility.** Store quicklime and dry hydrated lime in closed, weatherproof containers.
- 3.2. **Slurry Equipment.** Use slurry tanks equipped with agitation devices to slurry hydrated lime or quicklime on the project or other approved location. The Engineer may approve other slurring methods.

- 3.3. Provide a pump for agitating the slurry when the distributor truck is not equipped with an agitator. Equip the distributor truck with a sampling device in accordance with Tex-600-J, Part I, when using commercial lime slurry or carbide lime slurry.
- 3.4. **Hydrated Lime Distribution Equipment.** Provide equipment to spread lime evenly across the area to be treated. Provide equipment with a rotary vane feeder to spread lime, when shown on the plans.
- 3.5. **Pulverization Equipment.** Provide pulverization equipment that:
- cuts and pulverizes material uniformly to the proper depth with cutters that plane to a uniform surface over the entire width of the cut,
 - provides a visible indication of the depth of cut at all times, and
 - uniformly mixes the materials.

4. CONSTRUCTION

Construct each layer uniformly, free of loose or segregated areas, and with the required density and moisture content. Provide a smooth surface that conforms to the typical sections, lines, and grades shown on the plans or as directed.

- 4.1. **Preparation of Subgrade or Existing Base for Treatment.** Before treating, remove existing asphalt pavement in accordance with Item 105, "Removing Treated and Untreated Base and Asphalt Pavement," when shown on the plans or as directed. Shape existing material in accordance with applicable bid items to conform to typical sections shown on the plans and as directed.

Unless otherwise approved, proof roll the roadbed in accordance with Item 216, "Proof Rolling," before pulverizing or scarifying existing material. Correct soft spots as directed.

When material is imported from a borrow source, notify the Engineer of the location of the borrow source well in advance to allow time for testing and approval to avoid delay to the project. Stockpile as directed. The Engineer will test the borrow source and determine the sulfate and organic contents. When the borrow source has a sulfate content greater than 3,000 ppm or an organic content greater than 1.0%, proceed as directed.

When new base material is required to be mixed with existing base, deliver, place, and spread the new material in the required amount per station. Manipulate and thoroughly mix new base with existing material to provide a uniform mixture to the specified depth before shaping.

- 4.2. **Pulverization.** Pulverize or scarify existing material after shaping so that 100% passes a 2-1/2 in. sieve. If the material cannot be uniformly processed to the required depth in a single pass, excavate and windrow the material to expose a secondary grade to achieve processing to plan depth.

- 4.3. **Application of Lime.** Uniformly apply lime using dry or slurry placement as shown on the plans or as directed. Add lime at the percentage determined in Section 260.2.6., "Mix Design." Apply lime only on an area where mixing can be completed during the same working day.

Start lime application only when the air temperature is at least 35°F and rising or is at least 40°F. The temperature will be taken in the shade and away from artificial heat. Suspend application when the Engineer determines that weather conditions are unsuitable.

Minimize dust and scattering of lime by wind. Do not apply lime when wind conditions, in the opinion of the Engineer, cause blowing lime to become dangerous to traffic or objectionable to adjacent property owners. When pebble grade quicklime is placed dry, mix the material and lime thoroughly at the time of lime application. Use of quicklime can be dangerous. Inform users of the recommended precautions for handling and storage.

- 4.3.1. **Dry Placement.** Before applying lime, bring the prepared roadway to approximately 2 percentage points above optimum moisture content. When necessary, sprinkle in accordance with Item 204, "Sprinkling." Distribute the required quantity of hydrated lime or pebble grade quicklime with approved equipment. Only hydrated lime may be distributed by bag. Do not use a motor grader to spread hydrated lime.
- 4.3.2. **Slurry Placement.** Provide slurry free of objectionable materials, at or above the minimum dry solids content, and with a uniform consistency that will allow ease of handling and uniform application. Deliver commercial lime slurry or carbide lime slurry to the jobsite, or use hydrated lime or quicklime to prepare lime slurry at the jobsite or other approved location, as specified. When dry quicklime is applied as slurry, use 80% of the amount shown on the plans.
- Distribute slurry uniformly by making successive passes over a measured section of roadway until the specified lime content is reached. Uniformly spread the residue from quicklime slurry over the length of the roadway being processed, unless otherwise directed.
- 4.4. **Mixing.** Begin mixing within 6 hr. of application of lime. Hydrated lime exposed to the open air for 6 hr. or more between application and mixing, or that experiences excessive loss due to washing or blowing, will not be accepted for payment.

Thoroughly mix the material and lime using approved equipment. When treating subgrade, bring the moisture content above the optimum moisture content to insure adequate chemical reaction of the lime and subgrade materials. Allow the mixture to mellow for 1 to 4 days, as directed. When pebble grade quicklime is used, allow the mixture to mellow for 2 to 4 days, as directed. Sprinkle the treated materials during the mixing and mellowing operation, as directed, to achieve adequate hydration and proper moisture content. When the material to be treated has a sulfate content greater than 3,000 ppm but less than or equal to 7,000 ppm, mellow for a minimum of 7 days. Maintain in a continuously moist condition by sprinkling in accordance with Item 204, "Sprinkling." After mellowing, resume mixing until a homogeneous, friable mixture is obtained. After mixing, the Engineer may sample the mixture at roadway moisture and test in accordance with Tex-101-E, Part III, to determine compliance with the gradation requirements in Table 1.

Table 1
Gradation Requirements (Minimum % Passing)

Sieve Size	Base	Subgrade
1-3/4"	100	100
3/4"	85	85
#4	–	60

- 4.5. **Compaction.** Compact the mixture using density control, unless otherwise shown on the plans. Multiple lifts are permitted when shown on the plans or approved. Bring each layer to the moisture content directed. Sprinkle the treated material in accordance with Item 204, "Sprinkling" or aerate the treated material to adjust the moisture content during compaction so that it is no more than 1.0 percentage points below optimum and 2.0 percentage points above optimum as determined by Tex-121-E. Measure the moisture content of the material in accordance with Tex-115-E or Tex-103-E during compaction daily and report the results the same day, unless otherwise shown on the plans or directed.

Begin rolling longitudinally at the sides and proceed toward the center, overlapping on successive trips by at least 1/2 the width of the roller unit. On superelevated curves, begin rolling at the low side and progress toward the high side. Offset alternate trips of the roller. Operate rollers at a speed between 2 and 6 mph as directed.

Before final acceptance, the Engineer will select the locations of tests in each unit and measure the treated depth in accordance with Tex-140-E. Correct areas deficient by more than 1/2 in. in thickness or more than 1/2% in target lime content by adding lime as required, reshaping, recompacting, and refinishing at the Contractor's expense.

Rework, recompact, and refinish material that fails to meet or that loses required moisture, density, stability, or finish before the next course is placed or the project is accepted. Continue work until specification

requirements are met. Rework in accordance with Section 260.4.6., "Reworking a Section." Perform the work at no additional expense to the Department.

- 4.5.1. **Ordinary Compaction.** Roll with approved compaction equipment, as directed. Correct irregularities, depressions, and weak spots immediately by scarifying the areas affected, adding or removing treated material as required, reshaping, and recompacting.
- 4.5.2. **Density Control.** The Engineer will determine roadway density and moisture content of completed sections in accordance with Tex-115-E. The Engineer may accept the section if no more than 1 of the 5 most recent density tests is below the specified density and the failing test is no more than 3 pcf below the specified density.
- 4.5.2.1. **Subgrade.** Compact to at least 95% of the maximum density determined in accordance with Tex-121-E, unless otherwise shown on the plans.
- 4.5.2.2. **Base.** Compact the bottom course to at least 95% of the maximum density determined in accordance with Tex-121-E, unless otherwise shown on the plans. Compact subsequent courses treated under this Item to at least 98% of the maximum density determined in accordance with Tex-121-E, unless otherwise shown on the plans.
- 4.6. **Reworking a Section.** When a section is reworked within 72 hr. after completion of compaction, rework the section to provide the required density. When a section is reworked more than 72 hr. after completion of compaction, add additional lime at 25% of the percentage determined in Section 260.2.6., "Mix Design." Reworking includes loosening, adding material or removing unacceptable material if necessary, mixing as directed, compacting, and finishing. When density control is specified, determine a new maximum density of the reworked material in accordance with Tex-121-E, and compact to at least 95% of this density.
- 4.7. **Finishing.** Immediately after completing compaction of the final course, clip, skin, or tight-blade the surface of the lime-treated material with a maintainer or subgrade trimmer to a depth of approximately 1/4 in. Remove loosened material and dispose of at an approved location. Roll the clipped surface immediately with a pneumatic tire roller until a smooth surface is attained. Add small amounts of water as needed during rolling. Shape and maintain the course and surface in conformity with the typical sections, lines, and grades shown on the plans or as directed.
- Finish grade of constructed subgrade to within 0.1 ft. in the cross-section and 0.1 ft. in 16 ft. measured longitudinally.
- Correct grade deviations of constructed base greater than 1/4 in. in 16 ft. measured longitudinally or greater than 1/4 in. over the entire width of the cross-section in areas where surfacing is to be placed. Remove excess material, reshape, and roll with a pneumatic-tire roller. Correct as directed if material is more than 1/4 in. low. Do not surface patch. The 72-hr. time limit required for completion of placement, compaction, and finishing does not apply to finishing required just before applying the surface course.
- 4.8. **Curing.** Cure for the minimum number of days shown in Table 2 by sprinkling in accordance with Item 204, "Sprinkling," or by applying an asphalt material at a rate of 0.05 to 0.20 gal. per square yard as directed. Maintain moisture during curing. Upon completion of curing, maintain the moisture content in accordance with Section 132.3.5., "Maintenance of Moisture and Reworking," for subgrade and Section 247.4.5., "Curing" for bases before placing subsequent courses. Do not allow equipment on the finished course during curing except as required for sprinkling, unless otherwise approved. Apply seals or additional courses within 14 calendar days of final compaction.

Table 2
Minimum Curing Requirements before Placing Subsequent Courses¹

Untreated Material	Curing (Days)
PI ≤ 35	2
PI > 35	5

1. Subject to the approval of the Engineer. Proof rolling may be required as an indicator of adequate curing.

5. MEASUREMENT

- 5.1. **Lime.** When lime is furnished in trucks, the weight of lime will be determined on certified scales, or the Contractor must provide a set of standard platform truck scales at a location approved by the Engineer. Scales must conform to the requirements of Item 520, "Weighing and Measuring Equipment."

When lime is furnished in bags, indicate the manufacturer's certified weight. Bags varying more than 5% from that weight may be rejected. The average weight of bags in any shipment, as determined by weighing 10 bags taken at random, must be at least the manufacturer's certified weight.

5.1.1. Hydrated Lime.

- 5.1.1.1. **Dry.** Lime will be measured by the ton (dry weight).

- 5.1.1.2. **Slurry.** Lime slurry will be measured by the ton (dry weight) of the hydrated lime used to prepare the slurry at the jobsite.

- 5.1.2. **Commercial Lime Slurry.** Lime slurry will be measured by the ton (dry weight) as calculated from the minimum percent dry solids content of the slurry, multiplied by the weight of the slurry in tons delivered.

5.1.3. Quicklime.

- 5.1.3.1. **Dry.** Lime will be measured by the ton (dry weight) of the quicklime.

- 5.1.3.2. **Slurry.** Lime slurry will be measured by the ton (dry weight) of the quicklime used to prepare the slurry multiplied by a conversion factor of 1.28 to give the quantity of equivalent hydrated lime, which will be the basis of payment.

- 5.1.4. **Carbide Lime Slurry.** Lime slurry will be measured by the ton (dry weight) as calculated from the minimum percent dry solids content of the slurry, multiplied by the weight of the slurry in tons delivered.

- 5.2. **Lime Treatment.** Lime treatment will be measured by the square yard of surface area. The dimensions for determining the surface area are established by the widths shown on the plans and the lengths measured at placement.

6. PAYMENT

The work performed and materials furnished in accordance with this Item and measured as provided under "Measurement" will be paid in accordance with Section 260.6.1., "Lime," and Section 260.6.2., "Lime Treatment."

Furnishing and delivering new base will be paid for in accordance with Section 247.6.2., "Flexible Base (Roadway Delivery)." Mixing, spreading, blading, shaping, compacting, and finishing new or existing base material will be paid for in accordance with Section 260.6.2., "Lime Treatment." Removal and disposal of existing asphalt concrete pavement will be paid for in accordance with pertinent Items or Article 4.4., "Changes in the Work."

Sprinkling and rolling, except proof rolling, will not be paid for directly but will be subsidiary to this Item, unless otherwise shown on the plans. When proof rolling is shown on the plans or directed by the Engineer, it will be paid for in accordance with Item 216, "Proof Rolling."

Where subgrade is constructed under this Contract, correction of soft spots in the subgrade or existing base will be at the Contractor's expense. Where subgrade is not constructed under this Contract, correction of soft spots in the subgrade or existing base will be paid for in accordance with pertinent Items or Article 4.4., "Changes in the Work."

Where subgrade to be treated under this Contract has sulfates greater than 7,000 ppm, work will be paid for in accordance with Article 4.4., "Changes in the Work."

Asphalt used solely for curing will not be paid for directly but will be subsidiary to this Item. Asphalt placed for curing and priming will be paid for under Item 310, "Prime Coat."

6.1. **Lime.** Lime will be paid for at the unit price bid for "Lime" of one of the following types:

- Hydrated Lime (Dry),
- Hydrated Lime (Slurry),
- Commercial Lime Slurry,
- Quicklime (Dry),
- Quicklime (Slurry), or
- Carbide Lime Slurry.

This price is full compensation for materials, delivery, equipment, labor, tools, and incidentals.

Lime used for reworking a section in accordance with Section 260.4.6., "Reworking a Section," will not be paid for directly but will be subsidiary to this Item.

6.2. **Lime Treatment.** Lime treatment will be paid for at the unit price bid for "Lime Treatment (Existing Material)," "Lime Treatment (New Base)," or "Lime Treatment (Mixing Existing Material and New Base)," for the depth specified. No payment will be made for thickness or width exceeding that shown on the plans. This price is full compensation for shaping existing material, loosening, mixing, pulverizing, spreading, applying lime, compacting, finishing, curing, curing materials, blading, shaping and maintaining shape, replacing mixture, disposing of loosened materials, processing, hauling, preparing secondary subgrade, water, equipment, labor, tools, and incidentals.

Item 263

Lime Treatment (Plant-Mixed)



1. DESCRIPTION

Construct a base course composed of a mixture of flexible base, hydrated lime, and water, mixed in an approved plant.

2. MATERIALS

Furnish uncontaminated materials of uniform quality that meet the requirements of the plans and specifications. Notify the Engineer of proposed sources of materials and of changes to material sources. The Engineer will verify that the requirements of this Item are met before the sources can be used. The Engineer may sample and test project materials at any time before compaction. Use Tex-100-E for material definitions.

- 2.1. **Lime.** Furnish hydrated lime that meets the requirements of DMS-6350, "Lime and Lime Slurry," and DMS-6330, "Pre-Qualification of Lime Sources."
- 2.2. **Flexible Base.** Furnish base material that meets the requirements of Item 247, "Flexible Base," for the type and grade shown on the plans, before the addition of lime.
- 2.3. **Water.** Furnish water free of industrial wastes and other objectionable material.
- 2.4. **Asphalt.** Furnish asphalt or emulsion when permitted for curing purposes that meets the requirements of Item 300, "Asphalts, Oils, and Emulsions," as shown on the plans or as directed.
- 2.5. **Mix Design.** Using the materials proposed for the project, the Engineer will determine the target lime content and optimum moisture content necessary to produce the required stabilized mixture. The mix will be designed in accordance with Tex-121-E. The Contractor may propose a mix design developed in accordance with Tex-121-E. The Engineer will use Tex-121-E to verify the Contractor's proposed mix design before acceptance. Reimburse the Department for subsequent mix designs or partial designs necessitated by changes in the material or requests by the Contractor. Limit the amount of asphalt concrete pavement to no more than 50% of the mix when treating existing materials unless otherwise shown on the plans or directed.

3. EQUIPMENT

Provide machinery, tools, and equipment necessary for proper execution of the work. Provide rollers in accordance with Item 210, "Rolling." Provide proof rollers in accordance with Item 216, "Proof Rolling," when required.

- 3.1. **Storage Facility.** Store hydrated lime in closed weatherproof containers.
- 3.2. **Mixing Plant.** Provide a stationary pugmill that uniformly mixes lime, water, and base material in the specified proportions. Obtain approval before providing weigh-batch or continuous mixers. Equip plants with automatic proportioning and metering devices. Ensure weighing and measuring equipment complies with Item 520, "Weighing and Measuring Equipment." Provide calibration documentation.
- 3.3. **Spreader Equipment.** Provide equipment that will spread the lime-treated mixture in a uniform layer in one pass when shown on the plans. Equip spreaders with electronic grade controls when shown on the plans.

4. CONSTRUCTION

Construct each layer uniformly, free of loose or segregated areas, and with the required density and moisture content. Provide a smooth surface that conforms to the typical sections, lines, and grades shown on the plans or as directed. Complete placing, compacting, and finishing within 72 hr. after the lime is added to the base material.

Start lime operations only when the air temperature is at least 35°F and rising or is at least 40°F. The temperature will be taken in the shade and away from artificial heat. Suspend operations when the Engineer determines that weather conditions are unsuitable.

- 4.1. **Mixing.** Thoroughly mix materials in the proportions designated on the mix design, in a plant that meets the requirements of Section 263.3.2., "Mixing Plant." Mix at optimum moisture content, unless otherwise directed, until a homogeneous mixture is obtained.

- 4.2. **Placing.** Place lime-treated base on a subgrade or base prepared in accordance with details shown on the plans. Bring the prepared roadway to the moisture content directed. Haul lime-treated base to the roadway in clean trucks and begin placement immediately. Spread and shape in a uniform layer with an approved spreader. Construct individual layers to the thickness shown on the plans, the same day as delivered, unless otherwise approved. Do not place lifts exceeding a compacted depth of 8 in. unless otherwise shown on the plans. Maintain the shape of the course by blading. Correct or replace segregated areas as directed, at no additional expense to the Department.

Construct vertical joints between segmented areas of lime-treated base. The vertical face may be created by using a header or by cutting back the face to approximately vertical. Place successive base courses using the same methods as the first course. Offset construction joints by at least 6 in.

- 4.3. **Compaction.** Compact the mixture using density control immediately after placing unless otherwise shown on the plans. Multiple lifts are permitted when shown on the plans or approved. Bring each layer to the moisture content directed. Sprinkle the treated material when necessary in accordance with Item 204, "Sprinkling." Determine the moisture content of the mixture at the beginning and during compaction in accordance with Tex-103-E.

Begin rolling longitudinally at the sides and proceed towards the center, overlapping on successive trips by at least 1/2 the width of the roller unit. Begin rolling at the low side and progress toward the high side on superelevated curves. Offset alternate trips of the roller. Operate rollers at a speed between 2 and 6 mph, as directed.

Rework, recompact, and refinish material that fails to meet or that loses required moisture, density, stability, or finish before the next course is placed or the project is accepted. Continue work until specification requirements are met. Rework in accordance with Section 263.4.4., "Reworking a Section." Perform the work at no additional expense to the Department.

- 4.3.1. **Ordinary Compaction.** Roll with approved compaction equipment as directed. Correct irregularities, depressions, and weak spots immediately by scarifying the areas affected, adding or removing treated material as required, reshaping, and recompacting.

- 4.3.2. **Density Control.** Compact the bottom course to at least 95% of the maximum density determined in accordance with Tex-121-E, unless otherwise shown on the plans. Compact subsequent courses treated under this Item to at least 98% of the maximum density determined in accordance with Tex-121-E, unless otherwise shown on the plans.

The Engineer will determine roadway density and moisture content of completed sections in accordance with Tex-115-E. The Engineer may accept the section if no more than 1 of the 5 most recent density tests is below the specified density and the failing test is no more than 3 pcf below the specified density.

- 4.4. **Reworking a Section.** Rework the section, without adding additional lime, to provide the required density when a section is reworked within 72 hr. after completion of compaction. Add additional lime at the rate of 25% of the percentage determined in Section 263.2.5., "Mix Design," when a section is reworked more than 72 hr. after the completion of compaction. Reworking includes loosening, adding material or removing unacceptable material if necessary, road-mixing as directed, compacting, and finishing. Determine the new maximum density of the reworked material in accordance with Tex-121-E when density control is specified, and compact to at least 95% of this density. The Contractor has the option of removing the failing material and replacing it with acceptable lime-treated mix.
- 4.5. **Finishing.** Clip, skin, or tight-blade the surface of the lime-treated material with a maintainer to a depth of approximately 1/4 in immediately after completing compaction of the final course. Remove loosened material and dispose of it at an approved location. Seal the clipped surface immediately by rolling with a pneumatic-tire roller until a smooth surface is attained. Add small increments of water as needed during rolling. Shape and maintain the course and surface in conformity with the typical sections, lines, and grades shown on the plans or as directed.
- Correct grade deviations greater than 1/4 in. in 16 ft. measured longitudinally or greater than 1/4 in. over the entire width of the cross-section in areas where surfacing is to be placed. Remove excess material, reshape, and roll with a pneumatic-tire roller. Correct as directed if material is more than 1/4 in. low. Do not surface patch. The 72-hr. time limit required for completion of placement, compaction, and finishing does not apply to finishing required just before applying the surface course.
- 4.6. **Curing.** Cure for at least 7 days, unless otherwise approved, by sprinkling in accordance with Item 204, "Sprinkling," or by applying an asphalt material at a rate of 0.05 to 0.20 gal. per square yard as directed. Maintain moisture during curing. Continue curing until placing another course or opening to traffic. Open to traffic as directed. Do not allow equipment on the finished course during curing except as required for sprinkling, unless otherwise approved. Apply seals or additional courses within 14 days of final compaction.

5. MEASUREMENT

Lime-treated base will be measured by the cubic yard, square yard, or ton, as a composite mixture of lime, flexible base, and recycled materials.

Measurement by the cubic yard in final position and by the square yard is plans quantity measurement. The quantity to be paid for is the quantity shown in the proposal unless modified by Article 9.2., "Plans Quantity Measurement." Additional measurements or calculations will be made if adjustments of quantities are required.

Measurement is further defined for payment as follows:

- 5.1. **Cubic Yard in Vehicles.** Lime-treated base will be measured by the cubic yard in vehicles as delivered on the road.
- 5.2. **Cubic Yard in Final Position.** Lime-treated base will be measured by the cubic yard in its final position. The volume of each course will be computed in-place between the original subgrade surfaces and the lines, grades, and slopes of the accepted base course as shown on the plans and calculated by the method of average end areas.
- 5.3. **Square Yard.** Lime-treated base will be measured by the square yard of surface area. The dimensions for determining the surface area are established by the dimensions shown on the plans.
- 5.4. **Ton.** Lime-treated base will be measured by the ton (dry weight) in vehicles as delivered on the road. The dry weight is determined by deducting the weight of the moisture in the material at the time of weighing from the gross weight of the material. The Engineer will determine the moisture content in the material in accordance with Tex-103-E, from samples taken at the time of weighing.

When material is measured in trucks, the weight of the material will be determined on certified scales, or the Contractor must provide a set of standard platform truck scales at a location approved by the Engineer. Scales must conform to the requirements of Item 520, "Weighing and Measuring Equipment."

6. PAYMENT

The work performed and materials furnished in accordance with this Item and measured as provided under "Measurement" will be paid for at the unit price bid for "Lime Treatment (Plant-Mixed)," of the flexible base type, grade, and thickness (for square yard measurement) specified. For cubic yard measurement, "In Vehicle" or "Final Position" will be specified. This price is full compensation for furnishing and disposing of materials (including lime and base); storing, mixing, hauling, placing, sprinkling, compacting, finishing, curing, and maintaining and reworking of treated base; and equipment, labor, tools, and incidentals.

Sprinkling and rolling, except proof rolling, will not be paid for directly but will be subsidiary to this Item, unless otherwise shown on the plans. When proof rolling is shown on the plans or directed by the Engineer, it will be paid for in accordance with Item 216, "Proof Rolling."

Where subgrade or base courses are constructed under this Contract, correction of soft spots will be at the Contractor's expense. Where subgrade or base is not constructed under this Contract, correction of soft spots will be in accordance with pertinent Items or Article 4.4., "Changes in the Work."

Asphalt used solely for curing will not be paid for directly but will be subsidiary to this Item. Asphalt placed for curing and priming will be paid for under Item 310, "Prime Coat."

Removal and disposal of existing asphalt concrete pavement will be paid for in accordance with pertinent Items or Article 4.4., "Changes in the Work."

6.1. **Thickness Measurement for Cubic Yard In Final Position and Square Yard Payment Adjustment.**

Before final acceptance, the Engineer will select the locations of tests within each unit and measure the treated base depths in accordance with Tex-140-E.

6.1.1. **Units for Payment Adjustment.**

6.1.1.1. **Roadways and Shoulders.** Units for applying a payment adjustment for thickness to roadways and shoulders are defined as 1,000 ft. of treated base in each placement width. The last unit in each placement width will be 1,000 ft. plus the fractional part of 1,000 ft. remaining. Placement width is the width between longitudinal construction joints. For widening, the placement width is the average width placed of the widened section that is deficient in thickness.

6.1.1.2. **Ramps and Other Areas.** Units are defined as 2,000 sq. yd. or fraction thereof for establishing an adjusted unit price for ramps, intersections, irregular sections, crossovers, entrances, partially completed units, transitions to ramps, and other areas designated by the Engineer.

6.1.2. **Price Adjustments of Deficient Areas.**

6.1.2.1. **Thickness Deficiency \leq 1.0 in.** Table 1 will govern the price adjustment for each unit with deficient areas \leq 1.0 in.

**Table 1
Measurements and Price Adjustment for Each Unit**

Thickness Deficiency	Minimum Number of Additional Measurements	Average Thickness Deficiency of 3 Measurements	Price Adjustment
≤ 0.5 in.	None	N/A	Full Payment
> 0.5 in.	2	≤ 0.5 in.	Full Payment
		> 0.5 in. and ≤ 0.8 in.	75% Payment
		> 0.8 in. and ≤ 1.0 in.	50% Payment
		> 1.0 in.	In accordance with Section 263.6.1.2.2., "Thickness Deficiency > 1.0 in."

6.1.2.2. **Thickness Deficiency > 1.0 in.** Remove and replace areas of treated base found deficient in thickness by more than 1.0 in., unless otherwise approved. Take exploratory measurements at 50-ft. intervals parallel to the centerline in each direction from the deficient measurement until a measurement is not deficient by more than 1.0 in. If, in the judgment of the Engineer, the area of deficient thickness should not be reworked, there will be no payment for the area left in place. The minimum limit of non-pay will be 100 ft.

6.2. **Excess Thickness and Width.** For cubic yard in final position and square yard measurement, no additional payment will be made for thickness or width exceeding that shown on the plans.

Item 265

Fly Ash or Lime-Fly Ash Treatment (Road-Mixed)



1. DESCRIPTION

Mix and compact water, fly ash (FA) or lime and fly ash (LFA), and subgrade or base (with or without asphalt concrete pavement) in the roadway.

2. MATERIALS

Furnish uncontaminated materials of uniform quality that meet the requirements of the plans and specifications. Notify the Engineer of proposed material sources and of changes in material sources. The Engineer will verify that the specification requirements are met before the sources can be used. The Engineer may sample and test project materials at any time before compaction. Changes in material suppliers may require a new mix design. Use Tex-100-E for material definitions.

- 2.1. **Lime.** Furnish lime that meets the requirements of DMS-6350, "Lime and Lime Slurry," and DMS-6330, "Pre-Qualification of Lime Sources." Use hydrated lime, commercial lime slurry, or quicklime as shown on the plans. When furnishing quicklime, provide it in bulk.
- 2.2. **Fly Ash.** Furnish FA that meets the requirements of DMS-4615, "Fly Ash for Soil Treatment." Use Class CS or FS as shown on the plans.
- 2.3. **Subgrade.** The Engineer will determine the sulfate content in accordance with Tex-145-E and organic content in accordance with Tex-148-E before addition of lime or fly ash. Suspend operations when material to be treated has a sulfate content greater than 7,000 ppm or an organic content greater than 1.0% and proceed as directed.
- 2.4. **Flexible Base.** Unless otherwise shown on the plans, furnish base material that meets the requirements of Item 247, "Flexible Base," for the type and grade shown on the plans, before the addition of lime or FA.
- 2.5. **Water.** Furnish water free of industrial wastes and other objectionable matter.
- 2.6. **Asphalt.** When permitted for curing purposes, furnish asphalt or emulsion in accordance with Item 300, "Asphalts, Oils, and Emulsions," as shown on the plans or as directed.
- 2.7. **Mix Design.** The Engineer will determine the target FA or LFA content and optimum moisture content in accordance with Tex-127-E or prior experience with the project materials. The Contractor may propose a mix design developed in accordance with Tex-127-E. Meet strength requirements when shown on the plans. The Engineer will use Tex-127-E to verify the Contractor's proposed mix design before acceptance and will establish the approved additive blend and quantity. Reimburse the Department for subsequent mix designs or partial designs necessitated by changes in the material or requests by the Contractor. Limit the amount of recycled asphalt pavement to no more than 50% of the mix unless otherwise shown on the plans or directed.

3. EQUIPMENT

Provide machinery, tools, and equipment necessary for proper execution of the work. Provide rollers in accordance with Item 210, "Rolling." Provide proof rollers in accordance with Item 216, "Proof Rolling," when directed.

- 3.1. **Storage Facility.** Store quicklime, dry hydrated lime, and FA in closed, weatherproof containers.

- 3.2. **Slurry Equipment.** Use slurry tanks equipped with agitation devices to slurry hydrated lime or quicklime on the project or other approved location. The Engineer may approve other slurring methods.

Provide a pump for agitating the slurry when the distributor truck is not equipped with an agitator. Equip the distributor truck with a sampling device in accordance with Tex-600-J, Part I, when using commercial lime slurry.

- 3.3. **Distribution Equipment.** Provide equipment to spread lime and fly ash evenly across the area to be treated. Provide equipment with a rotary vane feeder to spread lime, when shown on the plans.

- 3.4. **Pulverization Equipment.** Provide pulverization equipment that:

- cuts and pulverizes material uniformly to the proper depth with cutters that will plane to a uniform surface over the entire width of the cut,
- provides a visible indication of the depth of cut at all times, and
- uniformly mixes the materials.

4. CONSTRUCTION

Construct each layer uniformly, free of loose or segregated areas and with the required density and moisture content. Provide a smooth surface that conforms to the typical sections, lines, and grades shown on the plans or as directed.

- 4.1. **Preparation of Subgrade or Existing Base for Treatment.** Before treating, remove existing asphalt concrete pavement in accordance with pertinent Items and the plans or as directed. Shape existing material in accordance with applicable bid items to conform to typical sections shown on the plans and as directed.

When shown on the plans or as directed, proof-roll the roadbed in accordance with Item 216, "Proof Rolling," before pulverizing or scarifying existing material. Correct soft spots as directed.

When material is imported from a borrow source, notify the Engineer of the location of the borrow source well in advance to allow time for testing and approval to avoid delay to the project. Stockpile as directed. The Engineer will test the borrow source and determine the sulfate and organic contents. When the borrow source has a sulfate content greater than 3,000 ppm or an organic content greater than 1.0%, proceed as directed.

When new base material is required to be mixed with existing base, deliver, place, and spread the new material in the required amount per station. Manipulate and thoroughly mix new base with existing material to provide a uniform mixture to the specified depth before the addition of lime or FA.

- 4.2. **Pulverization.** Pulverize or scarify material after shaping so that 100% passes a 2-1/2 in. sieve. If the material cannot be uniformly processed to the required depth in a single pass, excavate and windrow the material to expose a secondary grade to achieve processing to plan depth.

- 4.3. **Application and Mixing of FA or LFA.** When treating with LFA, apply, mix, and mellow lime first unless otherwise directed.

Start treatment operations only when the air temperature is at least 35°F and rising or is at least 40°F. Cease operations if the 24-hour projected air temperature is less than 32°F for more than 4 hours. The temperature will be taken in the shade and away from artificial heat. Suspend operations when the Engineer determines that weather conditions are unsuitable.

Minimize dust and scattering by wind. Do not apply lime or FA when wind conditions, in the opinion of the Engineer, cause blowing lime or FA to become dangerous to traffic or objectionable to adjacent property owners.

During the interval between application and mixing, sections treated with hydrated lime or fly ash that have been exposed to the open air for a period of 6 hr. or more, or that experience excessive loss due to washing or blowing, will not be accepted for payment.

After mixing and required mellowing, the Engineer may sample the mixture at roadway moisture and test in accordance with Tex-101-E, Part III, to determine compliance with the gradation requirements in Table 1.

Table 1
Gradation Requirements (Minimum % Passing)

Sieve Size	Base	Subgrade
1-3/4"	100	100
3/4"	85	85
#4	—	60

- 4.3.1. **Application of Lime.** Uniformly apply lime using dry or slurry placement as shown on the plans or as directed. Add lime at the percentage determined in Section 265.2.7., "Mix Design." Apply lime only on an area where mixing can be completed during the same working day.
- 4.3.1.1. **Dry Placement.** Before applying lime, bring the prepared roadway to approximately 2 percentage points above optimum moisture content. When necessary, sprinkle in accordance with Item 204, "Sprinkling." Distribute the required quantity of hydrated lime or pebble-grade quicklime with approved equipment. Only hydrated lime may be distributed by bag. Do not use a motor grader to spread hydrated lime.
- 4.3.1.2. **Slurry Placement.** Provide slurry free of objectionable materials, at or above the approved minimum dry solids content, and with a uniform consistency that will allow ease of handling and uniform application. Deliver commercial lime slurry to the jobsite or prepare lime slurry at the jobsite or other approved location by using hydrated lime or quicklime, as specified. When dry quicklime is applied as slurry, use 80% of the amount shown on the plans.
- Distribute slurry uniformly by making successive passes over a measured section of roadway until the specified lime content is reached. Uniformly spread the residue from quicklime slurry over the length of the roadway being processed unless otherwise directed.
- 4.3.2. **Mixing of Lime.** Begin mixing within 6 hr. of lime application. Thoroughly mix the material and lime using approved equipment. When treating subgrade, bring the moisture content above the optimum moisture content to insure adequate chemical reaction of the lime and subgrade materials. Allow the mixture to mellow for 1 to 4 days as directed. When pebble-grade quicklime is used, allow the mixture to mellow for 2 to 4 days as directed. Sprinkle the treated materials during the mixing and mellowing operation, as directed, to achieve adequate hydration and proper moisture content. When the material to be treated has a sulfate content greater than 3,000 ppm but less than or equal to 7,000 ppm, mellow for a minimum of 7 days. Maintain in a continuously moist condition by sprinkling in accordance with Item 204, "Sprinkling." After mellowing, resume mixing until a homogeneous, friable mixture is obtained.
- 4.3.3. **Application of Fly Ash.** Uniformly apply FA in dry form unless otherwise approved. Apply at the percentage determined in Section 265.2.7., "Mix Design." Apply FA only on that area where the mixing and compacting operations can be completed during the same working day. Do not use a motor grader to spread FA.
- For LFA treatment, begin FA application within 4 days after the lime mixing operation has been completed unless otherwise approved.
- 4.3.4. **Mixing of Fly Ash.** Thoroughly dry-mix the material and fly ash using approved equipment until a loose, homogeneous mixture is obtained. Sprinkle in accordance with Item 204, "Sprinkling," as directed, to achieve adequate mixing and hydration moisture. Prevent formation of fly ash balls.
- 4.3.5. **Final Mixture.** After mixing and required mellowing, the Engineer may sample the mixture at roadway moisture and test in accordance with Tex-101-E, Part III, to determine compliance with the gradation requirements in Table 1.

- 4.4. **Compaction.** Compact immediately after mixing the last stabilizing agent. Use density control unless otherwise shown on the plans. Complete all compaction operations within 6 hr. of FA application for type FS and within 2 hr. when using type CS. Multiple lifts are permitted when shown on the plans or approved by the Engineer. Sprinkle the treated material in accordance with Item 204, "Sprinkling," or aerate to bring each layer to the moisture content directed. Measure the moisture content of the material in accordance with Tex-115-E or Tex-103-E during compaction daily and report the results the same day to the Engineer, unless otherwise shown on the plans or directed.
- Begin rolling longitudinally at the sides and proceed towards the center, overlapping on successive trips by at least 1/2 the width of the roller unit. On superelevated curves, begin rolling at the low side and progress toward the high side. Offset alternate trips of the roller. Operate rollers at a speed between 2 to 6 mph as directed.
- Before final acceptance, the Engineer will select the locations of tests in each unit and measure the treated depth in accordance with Tex-140-E. Correct areas deficient by more than 1/2 in. in thickness or more than 1/2% in target lime or fly ash content by adding lime or fly ash as required, reshaping, recompacting, and refinishing at the Contractor's expense.
- Rework, recompact, and refinish material that fails to meet or that loses required moisture, density, stability, or finish before the next course is placed or the project is accepted. Continue work until specification requirements are met. Rework in accordance with Section 265.4.5., "Reworking a Section." Perform the work at no additional expense to the Department.
- 4.4.1. **Ordinary Compaction.** Roll with approved compaction equipment as directed. Correct irregularities, depressions, and weak spots immediately by scarifying the areas affected, adding or removing treated material as required, reshaping, and recompacting.
- 4.4.2. **Density Control.** The Engineer will determine roadway density of completed sections in accordance with Tex-115-E. Perform measurements immediately following completion of layer compaction. The Engineer may accept the section if no more than 1 of the 5 most recent density tests is below the specified density and the failing test is no more than 3 pcf below the specified density.
- 4.4.2.1. **Subgrade.** Compact to at least 95% of the maximum density determined in accordance with Tex-127-E unless otherwise shown on the plans.
- 4.4.2.2. **Base.** Compact the bottom course to at least 95% of the maximum density determined in accordance with Tex-127-E unless otherwise shown on the plans. Compact subsequent courses treated under this Item to at least 98% of the maximum density determined in accordance with Tex-127-E unless otherwise shown on the plans.
- 4.5. **Reworking a Section.** Reworking includes loosening, adding material or removing unacceptable material if necessary, mixing as directed, compacting, and finishing. The Contractor has the option of removing failing material and replacing it with acceptable material.
- Add LFA when reworking LFA-treated sections, or FA when reworking FA-treated sections, at the rate of at least 25% of the percentage determined in Section 265.2.7., "Mix Design," as directed. When repulverization of the failing section is not achievable, remove failing material and replace with acceptable treated material.
- When density control is specified, determine a new maximum density of the reworked material in accordance with Tex-127-E, and compact in accordance with Section 265.4.4.2., "Density Control." Compact as directed when ordinary compaction is specified.
- 4.6. **Finishing.** Complete finishing operations within 2 hr. after final compaction. Immediately after completing compaction of the final course, clip, skin, or tight-blade the surface with a maintainer or subgrade trimmer to a depth of approximately 1/4 in. Remove loosened material and dispose of it at an approved location. Seal the clipped surface immediately by rolling with a pneumatic tire roller until a smooth surface is attained. When finishing treated base, use a steel wheel roller before rolling with the pneumatic tire roller. Add small

increments of water as needed during rolling. Shape and maintain the course and surface in conformity with the typical sections, lines, and grades.

Finish grade of constructed subgrade to within 0.1 ft. in the cross-section and 0.1 ft. in 16 ft. measured longitudinally.

Correct grade deviations of constructed base greater than 1/4 in. in 16 ft. measured longitudinally or greater than 1/4 in. over the entire width of the cross-section in areas where surfacing is to be placed. Remove excess material, reshape, and roll with a pneumatic-tire roller. Correct as directed if material is more than 1/4 in. low. Do not surface patch.

- 4.7. **Curing.** Cure by maintaining in a thorough and continuously moist condition by sprinkling in accordance with Item 204, "Sprinkling." When permitted, cure with an asphalt material applied at a rate of 0.05 to 0.20 gal. per square yard as approved. Do not allow equipment on the finished course during curing except as required for sprinkling, unless otherwise approved.
- 4.7.1. **FA or LFA-Treated Sections with FS.** Cure the finished section for 7 days before adding another course or opening to traffic unless otherwise directed. Apply subsequent courses within 14 calendar days of completion of final compaction of the underlying treated course unless otherwise approved.
- 4.7.2. **FA-Treated Sections with CS.** Cure the finished section for at least 24 hr. before opening to traffic unless otherwise directed. Curing may be accomplished by placing material to be used in the subsequent course instead of moist-curing. Allow the treated course to dry for at least 48 hr. before applying a prime coat.

5. MEASUREMENT

- 5.1. **Lime.** When lime is furnished in trucks, the weight of lime will be determined on certified scales, or the Contractor must provide a set of standard platform truck scales at a location approved by the Engineer. Scales must conform to the requirements of Item 520, "Weighing and Measuring Equipment."
- When lime is furnished in bags, each bag must indicate the manufacturer's certified weight. Bags varying more than 5% from that weight may be rejected. The average weight of bags in any shipment, as determined by weighing 10 bags taken at random, must be at least the manufacturer's certified weight.
- 5.1.1. **Hydrated Lime.**
- 5.1.1.1. **Dry.** Lime will be measured by the ton (dry weight).
- 5.1.1.2. **Slurry.** Lime will be measured by the ton (dry weight) of the hydrated lime used to prepare the lime slurry at the jobsite.
- 5.1.2. **Commercial Lime Slurry.** Lime slurry will be measured by the ton (dry weight) as calculated from the minimum percent dry solids content of the slurry, multiplied by the weight of the slurry in tons delivered.
- 5.1.3. **Quicklime.**
- 5.1.3.1. **Dry.** Lime will be measured by the ton (dry weight).
- 5.1.3.2. **Slurry.** Lime slurry will be measured by the ton (dry weight) of the quicklime used to prepare the slurry, multiplied by a conversion factor of 1.28 to give the quantity of equivalent hydrated lime, which will be the basis of payment.
- 5.2. **Fly Ash.** FA will be measured by the ton (dry weight). When FA is furnished in trucks, the weight of FA will be determined on certified scales, or the Contractor must provide a set of standard platform truck scales at a location approved by the Engineer. Scales must conform to the requirements of Item 520, "Weighing and Measuring Equipment."

When fly ash is furnished in bags, each bag must indicate the manufacturer's certified weight. Bags varying more than 5% from that weight may be rejected. The average weight of bags in any shipment, as determined by weighing 10 bags taken at random, must be at least the manufacturer's certified weight.

- 5.3. **FA and LFA Treatment.** FA and LFA treatment will be measured by the square yard of surface area. The dimensions for determining the surface area are established by the widths shown on the plans and the lengths measured at placement.

6. PAYMENT

The work performed and materials furnished in accordance with this Item and measured as provided under "Measurement" will be paid in accordance with Section 265.6.1., "Lime"; Section 265.6.2., "Fly Ash"; and Section 265.6.3., "FA and LFA Treatment."

Furnishing and delivering new base will be paid for in accordance with Section 247.6.2., "Flexible Base (Roadway Delivery)." Mixing, spreading, blading, shaping, compacting, and finishing new or existing base material will be paid for under Section 265.6.3., "FA and LFA Treatment." Removal and disposal of existing asphalt concrete pavement will be paid for in accordance with pertinent Items or Article 4.4., "Changes in the Work."

Asphalt used solely for curing will not be paid for directly but will be subsidiary to this Item. Asphalt placed for curing and priming will be paid for under Item 310, "Prime Coat."

Lime and FA used for reworking a section in accordance with Section 265.4.5., "Reworking a Section," will not be paid for directly but will be subsidiary to this Item.

Sprinkling and rolling, except proof rolling, will not be paid for directly but will be subsidiary to this Item unless otherwise shown on the plans. When proof rolling is shown on the plans or directed by the Engineer, it will be paid for in accordance with Item 216, "Proof Rolling."

Where subgrade is constructed under this Contract, correction of soft spots in the subgrade or existing base will be at the Contractor's expense. Where subgrade is not constructed under this Contract, correction of soft spots in the subgrade or existing base will be in accordance with pertinent Items or Article 4.4., "Changes in the Work."

Where subgrade to be treated under this Contract has sulfates greater than 7,000 ppm, work will be paid for in accordance with Article 4.4., "Changes in the Work."

- 6.1. **Lime.** Lime will be paid for at the unit price bid for "Lime" of the specified type (Hydrated (Dry), Hydrated (Slurry), Commercial Lime Slurry, Quicklime (Dry), Quicklime (Slurry)). This price is full compensation for furnishing lime.
- 6.2. **Fly Ash.** FA will be paid for at the unit price bid for "Fly Ash" of the type specified. This price is full compensation for furnishing FA.
- 6.3. **FA and LFA Treatment.** FA and LFA treatment will be paid for at the unit price bid for "LFA Treated Subgrade," "FA Treated Subgrade," "LFA Treatment for Base Courses (Existing Base)," "FA Treatment for Base Courses (Existing Base)," "LFA Treatment for Base Courses (New Base)," "FA Treatment for Base Courses (New Base)," "LFA Treatment for Base Courses (New and Existing Base)," and "FA Treatment for Base Courses (New and Existing Base)," for the depth specified. No payment will be made for thickness or width exceeding that shown on the plans. This price is full compensation for shaping existing material, loosening, mixing, pulverizing, spreading, applying LFA, compacting, finishing, curing including curing materials, water, drying, blading, shaping and maintaining shape, replacing mixture, disposing of loosened materials, processing, hauling, reworking if required, preparing secondary subgrade, equipment, labor, tools, and incidentals.

Item 275

Cement Treatment (Road-Mixed)



1. DESCRIPTION

Mix and compact cement, water, and subgrade or base (with or without asphalt concrete pavement) in the roadway.

2. MATERIALS

Furnish uncontaminated materials of uniform quality that meet the requirements of the plans and specifications. Notify the Engineer of the proposed material sources and of changes to material sources. The Engineer will verify that the specification requirements are met before the sources can be used. The Engineer may sample and test project materials at any time before compaction. Use Tex-100-E for material definitions.

- 2.1. **Cement.** Furnish hydraulic cement that meets the requirements of DMS-4600, "Hydraulic Cement," and the Department's *Hydraulic Cement Quality Monitoring Program* (HCQMP). Sources not on the HCQMP will require testing and approval before use.
- 2.2. **Subgrade.** The Engineer will determine the sulfate content in accordance with Tex-145-E and organic content in accordance with Tex-148-E before cement treatment begins. Suspend operations when material to be treated has a sulfate content greater than 7,000 ppm or an organic content greater than 1.0% and proceed as directed.
- 2.3. **Flexible Base.** Unless otherwise shown on the plans, furnish base material that meets the requirements of Item 247, "Flexible Base," for the type and grade shown on the plans, before the addition of cement.
- 2.4. **Water.** Furnish water free of industrial waste and other objectionable material.
- 2.5. **Asphalt.** When permitted for curing purposes, furnish asphalt or emulsion that meets the requirements of Item 300, "Asphalts, Oils, and Emulsions," as shown on the plans or directed.
- 2.6. **Mix Design.** The Engineer will determine the target cement content and optimum moisture content to produce a stabilized mixture that meets the strength requirements shown on the plans. The mix will be designed in accordance with Tex-120-E or will be based on prior experience with the project materials. The Contractor may propose a mix design developed in accordance with Tex-120-E. Meet strength requirements when shown on the plans. The Engineer will use Tex-120-E to verify the Contractor's proposed mix design before acceptance. Reimburse the Department for subsequent mix designs or partial designs necessitated by changes in the material or requests by the Contractor. Limit the amount of recycled asphalt pavement to no more than 50% of the mix unless otherwise shown on the plans or directed.

3. EQUIPMENT

Provide machinery, tools, and equipment necessary for proper execution of the work. Provide rollers in accordance with Item 210, "Rolling." Provide proof rollers in accordance with Item 216, "Proof Rolling," when required.

- 3.1. **Cement Storage Facility.** Store cement in closed, weatherproof containers.
- 3.2. **Cement Slurry Equipment.** Use slurry tanks equipped with agitation devices to slurry cement on the project or other approved location. The Engineer may approve other slurring methods. Provide a pump for agitating

the slurry when the distributor truck is not equipped with an agitator. Equip the distributor truck with an approved sampling device.

- 3.3. **Dry Cement Distribution Equipment.** Provide equipment to spread cement evenly across the area to be treated. Provide equipment with a rotary vane feeder when shown on the plans.
- 3.4. **Pulverization Equipment.** Provide pulverization equipment that:
- cuts and pulverizes material uniformly to the proper depth with cutters that will plane to a uniform surface over the entire width of the cut,
 - provides a visible indication of the depth of cut at all times, and
 - uniformly mixes the materials.

4. CONSTRUCTION

Construct each layer uniformly, free of loose or segregated areas and with the required density and moisture content. Provide a smooth surface that conforms to the typical sections, lines, and grades shown on the plans or as directed.

- 4.1. **Preparation of Subgrade or Existing Base for Treatment.** Before treating, remove existing asphalt concrete pavement in accordance with pertinent Items and the plans or as directed. Shape existing material in accordance with applicable bid items to conform to the typical sections shown on the plans and as directed.

When shown on the plans or directed, proof roll the roadbed in accordance with Item 216, "Proof Rolling," before pulverizing or scarifying existing material. Correct soft spots as directed.

Provide the borrow source location well in advance when material is imported, to allow time for testing and approval to avoid delay to the project. Stockpile as directed. The Engineer will test the borrow source and determine the sulfate and organic contents. When the borrow source has a sulfate content greater than 3,000 ppm or an organic content greater than 1.0%, proceed as directed.

When new base is required to be mixed with existing base, deliver, place, and spread the new material in the required amount per station. Manipulate and thoroughly mix new base with existing material to provide a uniform mixture to the specified depth before shaping.

- 4.2. **Pulverization.** Pulverize or scarify existing material after shaping so that 100% passes a 2-1/2 in. sieve. If the material cannot be uniformly processed to the required depth in a single pass, excavate and windrow the material to expose a secondary grade to achieve processing to plan depth.
- 4.3. **Application of Cement.** Uniformly apply cement using dry placement unless otherwise shown on the plans. Add cement at the percentage determined in Section 275.2.6., "Mix Design." Apply cement only on an area where mixing, compacting, and finishing can be completed during the same working day.
- Start cement application only when the air temperature is at least 35°F and rising or is at least 40°F. The temperature will be taken in the shade and away from artificial heat. Suspend application when the Engineer determines that weather conditions are unsuitable.
- 4.3.1. **Dry Placement.** Before applying cement, bring the prepared roadway to approximately optimum moisture content. When necessary, sprinkle in accordance with Item 204, "Sprinkling." Distribute the required quantity of dry cement with approved equipment. Minimize dust and scattering of cement by wind. Do not apply cement when wind conditions, in the opinion of the Engineer, cause blowing cement to become dangerous to traffic or objectionable to adjacent property owners.
- 4.3.2. **Slurry Placement.** Mix the required quantity of cement with water, as approved. Provide slurry free of objectionable materials and with a uniform consistency that can be easily applied. Agitate the slurry

continuously. Apply slurry within 2 hours of adding water and when the roadway is at a moisture content drier than optimum. Distribute slurry uniformly by making successive passes over a measured section of the roadway until the specified cement content is reached.

- 4.4. **Mixing.** Thoroughly mix the material and cement using approved equipment. Mix until a homogeneous mixture is obtained. Sprinkle the treated materials during the mixing operation, as directed, to maintain optimum mixing moisture. Spread and shape the completed mixture in a uniform layer.

After mixing, the Engineer may sample the mixture at roadway moisture and test in accordance with Tex-101-E, Part III, to determine compliance with the gradation requirements in Table 1. When strength requirements are shown on the plans, the Engineer may sample the mixture to verify strength in accordance with Tex-120-E and adjust cement content to achieve the target strength for work going forward.

Table 1
Gradation Requirements Minimum % Passing

Sieve Size	Base	Subgrade
1-3/4"	100	100
3/4"	85	85
#4	–	60

- 4.5. **Compaction.** Compact the mixture in one lift using density control unless otherwise shown on the plans. Complete compaction within 2 hours after the application of water to the mixture of material and cement.

Sprinkle the treated material in accordance with Item 204, "Sprinkling," or aerate the treated material to adjust the moisture content during compaction so that it is within 2.0 percentage points of optimum as determined by Tex-120-E. Measure the moisture content of the material in accordance with Tex-115-E or Tex-103-E during compaction daily and report the results the same day to the Engineer, unless otherwise shown on the plans or directed. Adjust operations as required.

Begin rolling longitudinally at the sides and proceed towards the center, overlapping on successive trips by at least one-half the width of the roller unit. On superelevated curves, begin rolling at the low side and progress toward the high side. Offset alternate trips of the roller. Operate rollers at a speed between 2 and 6 mph, as directed.

Before final acceptance, the Engineer will select the locations of tests in each unit and measure the treated depth in accordance with Tex-140-E. Correct areas deficient by more than 1/2 in. in thickness or more than 1/2% in target cement content by adding cement as required, reshaping, re-compacting, and refinishing at the Contractor's expense.

Remove or rework areas that lose required stability, compaction, or finish, as directed. When a section is reworked more than 4 hr. after completion of compaction, add additional cement as directed. Provide additional work and material at no additional cost to the Department.

- 4.5.1. **Ordinary Compaction.** Roll with approved compaction equipment, as directed. Correct irregularities, depressions, and weak spots immediately by scarifying the areas affected, adding or removing treated material as required, reshaping, and recompacting.

- 4.5.2. **Density Control.** Achieve at least 95% of the maximum density determined in accordance with Tex-120-E when compaction is complete. The Engineer will determine roadway density and moisture content in accordance with Test Method Tex-115-E. The Engineer may verify strength in accordance with Tex-120-E and adjust cement content to achieve the target strength for work going forward. Remove material that does not meet density requirements or rework by adding the target cement content, reshaping, recompacting, and refinishing at the Contractor's expense.

The Engineer may accept the section if no more than 1 of the 5 most recent density tests is below the specified density and the failing test is no more than 3 pcf below the specified density.

- 4.6. **Finishing.** Immediately after completing compaction, clip, skin, or tight-blade the surface of the cement treated material with a maintainer or subgrade trimmer to a depth of approximately 1/4 in. Remove loosened material and dispose of it at an approved location. Roll the clipped surface immediately with a pneumatic-tire roller until a smooth surface is attained. Add small increments of water as needed during rolling. Shape and maintain the course and surface in conformity with the typical sections, lines and grades shown on the plans or as directed.

Finish grade of constructed subgrade to within 0.1 ft. in the cross-section and 0.1 ft. in 16 ft. measured longitudinally.

Correct grade deviations of constructed base greater than 1/4 in. in 16 ft. measured longitudinally or greater than 1/4 in. over the entire width of the cross-section in areas where surfacing is to be placed. Remove excess material, reshape, and roll with a pneumatic-tire roller. Correct as directed if material is more than 1/4 in. low. Do not surface patch.

- 4.7. **Microcracking.** When shown on the plans, maintain moisture content of the finished cement treated base for a period of 24 to 48 hr. During this time, but not sooner than 24 hr., roll the finished course with a vibratory roller to induce microcracking. The vibratory roller must be in accordance with Item 210, "Rolling," with a static weight equal to or more than 12 tons and the vibratory drum must be not less than 20 in. wide. The roller must travel at a speed of 2 mph, vibrating at maximum amplitude, and make 2 to 4 passes with 100% coverage exclusive of the outside 1 ft. of the surface crown, unless otherwise directed by the Engineer. Additional passes may be required to achieve the desired crack pattern as directed. Notify the Engineer 24 hours before the microcracking begins.
- 4.8. **Curing.** Cure for at least 3 days by sprinkling in accordance with Item 204, "Sprinkling," or by applying an asphalt material at the rate of 0.05 to 0.20 gal. per square yard, as shown on the plans or directed. When a section is microcracked, cure section for an additional 2 days after microcracking. Maintain the moisture content during curing at no lower than 2 percentage points below optimum. Continue curing until placing another course.

5. MEASUREMENT

- 5.1. **Cement.** Cement will be measured by the ton (dry weight). When cement is furnished in trucks, the weight of cement will be determined on certified scales, or the Contractor must provide a set of standard platform truck scales at a location approved by the Engineer. Scales must conform to the requirements of Item 520, "Weighing and Measuring Equipment."

When cement is furnished in bags, indicate the manufacturer's certified weight. Bags varying more than 5% from that weight may be rejected. The average weight of bags in any shipment, as determined by weighing 10 bags taken at random, must be at least the manufacturer's certified weight.

Cement slurry will be measured by the ton (dry weight) of the cement used to prepare the slurry at the jobsite or from the minimum percent dry solids content of the slurry, multiplied by the weight of the slurry in tons delivered.

- 5.2. **Cement Treatment.** Cement treatment will be measured by the square yard of surface area. The dimensions for determining the surface areas are established by the widths shown on the plans and lengths measured at placement.

6. PAYMENT

The work performed and materials furnished in accordance with this Item and measured as provided under "Measurement" will be paid in accordance with Section 275.5.1., "Cement," and Section 275.5.2., "Cement Treatment."

Furnishing and delivering new base will be paid for in accordance with Section 247.6.2., "Flexible Base (Roadway Delivery)." Mixing, spreading, blading, shaping, compacting, and finishing new or existing base material will be paid for under Section 275.6.2., "Cement Treatment." Removal and disposal of existing asphalt concrete pavement will be paid for in accordance with pertinent Items or Article 4.4., "Changes in the Work."

Sprinkling and rolling, except proof-rolling, will not be paid for directly but will be subsidiary to this Item, unless otherwise shown on the plans. When proof-rolling is shown on the plans or directed by the Engineer, it will be paid for in accordance with Item 216, "Proof Rolling."

Where subgrade is constructed under this Contract, correction of soft spots in the subgrade or existing base will be at the Contractor's expense. Where subgrade is not constructed under this Contract, correction of soft spots in the subgrade or existing base will be in accordance with pertinent Items or Article 4.4., "Changes in the Work."

Where subgrade to be treated under this Contract has sulfates greater than 7,000 ppm, work will be paid for in accordance with Article 4.4., "Changes in the Work."

Asphalt used solely for curing will not be paid for directly but will be subsidiary to this Item. Asphalt placed for the purpose of curing and priming will be paid for under Item 310, "Prime Coat."

- 6.1. **Cement.** Cement will be paid for at the unit price bid for "Cement." This price is full compensation for materials, delivery, equipment, labor, tools, and incidentals.
- 6.2. **Cement Treatment.** Cement treatment will be paid for at the unit price bid for "Cement Treatment (Existing Material)," "Cement Treatment (New Base)," or "Cement Treatment (Mixing Existing Material and New Base)," for the depth specified. No payment will be made for thickness or width exceeding that shown on the plans. This price is full compensation for shaping existing material, loosening, mixing, pulverizing, spreading, applying cement, compacting, microcracking, finishing, curing, curing materials, blading, shaping and maintaining shape, replacing mixture, disposing of loosened materials, processing, hauling, preparing secondary subgrade, water, equipment, labor, tools, and incidentals.

Item 276

Cement Treatment (Plant-Mixed)



1. DESCRIPTION

Construct a base course composed of flexible base, hydraulic cement, and water, mixed in an approved plant.

2. MATERIALS

Furnish uncontaminated materials of uniform quality that meet the requirements of the plans and specifications. Notify the Engineer of proposed sources of materials and of changes in material sources. The Engineer will verify that the specification requirements are met before the sources can be used. The Engineer may sample and test project materials at any time before compaction. Use Tex-100-E for material definitions.

- 2.1. **Cement.** Furnish hydraulic cement that meets the requirements of DMS-4600, "Hydraulic Cement," and the Department's *Hydraulic Cement Quality Monitoring Program* (HCQMP). Sources not on the HCQMP will require testing and approval before use.
- 2.2. **Flexible Base.** Furnish base material that meets the requirements of Item 247, "Flexible Base," for the type and grade shown on the plans, before the addition of cement.
- 2.3. **Water.** Furnish water that is free of industrial waste and other objectionable material.
- 2.4. **Asphalt.** Furnish asphalt or emulsion that meets the requirements of Item 300, "Asphalts, Oils, and Emulsions," when permitted for curing purposes as shown on the plans or as directed.
- 2.5. **Mix Design.** Using the materials proposed for the project, the Engineer will determine the target cement content and optimum moisture content necessary to produce a stabilized mixture meeting the strength requirements shown in Table 1 for the class specified on the plans. The mix will be designed in accordance with Tex-120-E. The Contractor may propose a mix design developed in accordance with Tex-120-E. The Engineer will use Tex-120-E to verify the Contractor's proposed mix design before acceptance. The Engineer may use project materials sampled from the plant or the quarry, and sampled by the Engineer or the Contractor, as determined by the Engineer. Limit the amount of asphalt concrete pavement to no more than 50% of the mix unless otherwise shown on the plans or directed.

Table 1
Strength Requirements

Class	7-Day Unconfined Compressive Strength, Min psi
L	500
M	300
N	As shown on the plans

3. EQUIPMENT

Provide machinery, tools, and equipment necessary for proper execution of the work. Provide rollers in accordance with Item 210, "Rolling." Provide proof rollers in accordance with Item 216, "Proof Rolling," when required.

- 3.1. **Cement Storage Facility.** Store cement in closed, weatherproof containers.

- 3.2. **Mixing Plant.** Provide a stationary pugmill, weigh-batch, or continuous mixing plant as approved. Equip plants with automatic proportioning and metering devices that produce a uniform mixture of base material, cement, and water in the specified proportions.
- 3.3. **Spreader Equipment.** Provide equipment that will spread the cement-treated mixture in a uniform layer in 1 pass when shown on the plans. Equip spreaders with electronic grade controls when shown on the plans.

4. CONSTRUCTION

Construct each layer uniformly, free of loose or segregated areas and with the required density and moisture content. Provide a smooth surface that conforms to the typical sections, lines, and grades shown on the plans or established by the Engineer. Start placement operations only when the air temperature is at least 35°F and rising or is at least 40°F. The temperature will be taken in the shade and away from artificial heat. Suspend operations when the Engineer determines that weather conditions are unsuitable.

- 4.1. **Mixing.** Thoroughly mix materials in the proportions designated on the mix design, in a mixing plant that meets the requirements of Section 276.3.2., "Mixing Plant." Mix at optimum moisture content, unless otherwise directed, until a homogeneous mixture is obtained. Do not add water to the mixture after mixing is completed unless directed. The Engineer may sample the mixture to verify strength in accordance with Tex-120-E and adjust cement content to achieve the target strength for work going forward.

- 4.2. **Placing.** Place the cement-treated base on a subgrade or base prepared in accordance with details shown on the plans. Bring the prepared roadway to the moisture content directed. Haul cement-treated base to the roadway in clean trucks and begin placement immediately. Place cement-treated base only on an area where compacting and finishing can be completed during the same working day. Spread and shape in a uniform layer with an approved spreader. Construct individual layers to the thickness shown on the plans. Maintain the shape of the course by blading. Correct or replace segregated areas as directed, at no additional expense to the Department.

Construct vertical joints between new cement-treated base and cement-treated base that has been in place 4 hr. or longer. The vertical face may be created by using a header or by cutting back the face to approximately vertical. Place successive base courses using the same methods as the first course. Offset construction joints by at least 6 in.

- 4.3. **Compaction.** Compact each layer immediately after placing. Complete compaction within 2 hr. after plant-mixing water with dry material. Complete compaction of the final lift within 5 hr. after adding water to the treated base used in the first lift when multiple lifts are permitted.

Moisture content in the mixture at the plant may be adjusted so that during compaction it is within 2.0 percentage points of optimum as determined by Tex-120-E. Measure the moisture content of the material in accordance with Tex-115-E or Tex-103-E during compaction daily and report the results the same, unless otherwise shown on the plans or directed. Maintain uniform moisture content by sprinkling the treated material in accordance with Item 204, "Sprinkling."

Begin rolling longitudinally at the sides and proceed towards the center, overlapping on successive trips by at least 1/2 the width of the roller unit. Begin rolling at the low side and progress toward the high side on superelevated curves. Offset alternate trips of the roller. Operate rollers at a speed between 2 and 6 mph, as directed.

Achieve at least 95% of maximum density determined in accordance with Tex-120-E when compaction is complete. The Engineer will determine roadway density and moisture content in accordance with Tex-115-E. Remove material that does not meet density requirements. Remove areas that lose required stability, compaction, or finish. Replace with cement-treated mixture, compact, and test in accordance with density control methods.

The Engineer may accept the section if no more than 1 of the 5 most recent density tests is below the specified density and the failing test is no more than 3 pcf below the specified density.

- 4.4. **Finishing.** Clip, skin, or tight blade the surface of the cement-treated material with a maintainer or subgrade trimmer to a depth of approximately 1/4 in. immediately after completing compaction. Remove loosened material and dispose of at an approved location. Roll the clipped surface immediately with a pneumatic tire roller until a smooth surface is attained. Add small increments of water as needed during rolling. Shape and maintain the course and surface in conformity with the typical sections, lines, and grades shown on the plans or as directed.

Trim grade deviations greater than 1/4 in. in 16 ft. measured longitudinally or greater than 1/4 in. over the entire width of the cross-section in areas where surfacing is to be placed. Remove excess material, reshape, and then roll with a pneumatic tire roller. Correct as directed if material is more than 1/4 in. low. Do not surface patch.

- 4.5. **Microcracking.** Maintain moisture content of the finished cement-treated base for a period of 24 to 48 hr. when shown on the plans. Roll the finished course with a vibratory roller to induce microcracking during this time, but not sooner than 24 hrs. The vibratory roller must be in accordance with Item 210, "Rolling," with a static weight equal to or more than 12 tons and the vibratory drum must be not less than 20 in. wide. The roller must travel at a speed of 2 mph, vibrating at maximum amplitude, and make 2 to 4 passes with 100% coverage exclusive of the outside 1 ft. of the surface crown, unless otherwise directed by the Engineer. Additional passes may be required to achieve the desired crack pattern as directed. Notify the Engineer 24 hr. before the microcracking begins.
- 4.6. **Curing.** Cure for at least 3 days by sprinkling in accordance with Item 204, "Sprinkling," or by applying an asphalt material at the rate of 0.05 to 0.20 gal. per square yard, as shown on the plans or directed. When a section is microcracked, cure section for an additional 2 days after microcracking. Maintain the moisture content during curing at no lower than 2 percentage points below optimum. Continue curing until placing another course.

5. MEASUREMENT

Cement-treated base will be measured by the ton, cubic yard, or square yard as a composite mixture of cement, flexible base, and recycled materials.

Measurement by the cubic yard in final position and square yard is a plans quantity measurement. The quantity to be paid for is the quantity shown in the proposal unless modified by Article 9.2., "Plans Quantity Measurement." Additional measurements or calculations will be made if adjustments of quantities are required.

Measurement is further defined for payment as follows:

- 5.1. **Cubic Yard in Vehicles.** Cement-treated base will be measured by the cubic yard in vehicles as delivered on the road.
- 5.2. **Cubic Yard in Final Position.** Cement-treated base will be measured by the cubic yard in its completed and accepted final position. The volume of each course will be computed in-place between the original subgrade surfaces and the lines, grades, and slopes of the accepted base course as shown on the plans, and calculated by the method of average end areas.
- 5.3. **Square Yard.** Cement-treated base will be measured by the square yard of surface area. The dimensions for determining the surface area are established by the dimensions shown on the plans.
- 5.4. **Ton.** Cement-treated base will be measured by the ton (dry weight) in vehicles as delivered on the road. The dry weight is determined by deducting the weight of the moisture in the material at the time of weighing from

the gross weight of the material. The Engineer will determine the moisture content in the material in accordance with Tex-103-E from samples taken at the time of weighing.

When material is measured in trucks, the weight of the material will be determined on certified scales, or the Contractor must provide a set of standard platform truck scales at an approved location. Scales must conform to the requirements of Item 520, "Weighing and Measuring Equipment."

6. PAYMENT

The work performed and materials furnished in accordance with this Item and measured as provided under "Measurement" will be paid for at the unit price bid for "Cement Treatment (Plant-Mix)" of the class (strength), flexible base type, grade, and thickness (for square yard measurement) specified. For cubic yard measurement, "In Vehicle" or "In Final Position" will be specified. This price is full compensation for furnishing and disposing of materials (including cement and base); storing, mixing, hauling, placing, sprinkling, compacting, microcracking, finishing, curing, and maintaining and reworking treated base; and equipment, labor, tools, and incidentals.

Sprinkling and rolling, except proof rolling, will not be paid for directly but will be subsidiary to this Item, unless otherwise shown on the plans. When proof rolling is shown on the plans or directed by the Engineer, it will be paid for in accordance with Item 216, "Proof Rolling."

Where subgrade or base courses are constructed under this Contract, correction of soft spots will be at the Contractor's expense. Where subgrade or base is not constructed under this Contract, correction of soft spots will be paid for in accordance with pertinent Items and Article 4.4., "Changes in the Work."

Asphalt used solely for curing will not be paid for directly but will be subsidiary to this Item. Asphalt placed for curing and priming will be paid for under Item 310, "Prime Coat."

Removal and disposal of existing asphalt concrete pavement will be paid for in accordance with pertinent Items or Article 4.4., "Changes in the Work."

- 6.1. **Thickness Measurement for Cubic Yard In Final Position and Square Yard Payment Adjustment.**
Before final acceptance, the Engineer will select the locations of tests within each unit and measure the treated base depths in accordance with Tex-140-E.
- 6.1.1. **Units for Payment Adjustment.**
 - 6.1.1.1. **Roadways and Shoulders.** Units for applying a payment adjustment for thickness to roadways and shoulders are defined as 1,000 ft. of treated base in each placement width. The last unit in each placement width will be 1,000 ft. plus the fractional part of 1,000 ft. remaining. Placement width is the width between longitudinal construction joints. For widening, the placement width is the average width placed of the widened section that is deficient in thickness.
 - 6.1.1.2. **Ramps and Other Areas.** Units are defined as 2,000 sq. yd. or fraction thereof for establishing an adjusted unit price for ramps, intersections, irregular sections, crossovers, entrances, partially completed units, transitions to ramps, and other areas designated by the Engineer.
- 6.1.2. **Price Adjustments of Deficient Areas.**
 - 6.1.2.1. **Thickness Deficiency \leq 1.0 in.** Table 2 will govern the price adjustment for each unit with deficient areas \leq 1.0 in.

Table 2
Measurements and Price Adjustment for Each Unit

Thickness Deficiency	Additional Measurements	Average Thickness Deficiency of 3 Measurements		Price Adjustment
≤ 0.5 in.	None	N/A		Full Payment
> 0.5 in.	2	≤ 0.5 in.		Full Payment
		> 0.5 in.	≤ 0.8 in.	75% Payment
		> 0.8 in.	≤ 1.0 in.	50% Payment
		> 1.0 in.		In accordance with Section 276.6.1.2.2., "Thickness Deficiency ≥ 1.0 in."

- 6.1.2.2. **Thickness Deficiency ≥ 1.0 in.** Remove and replace areas of treated base found deficient in thickness by more than 1.0 in., unless otherwise approved. Take exploratory measurements at 50-ft. intervals parallel to the centerline in each direction from the deficient measurement until a measurement is not deficient by more than 1.0 in. The minimum limit of non-pay will be 100 ft.
- 6.2. **Excess Thickness and Width.** For cubic yard in final position and square yard measurement, no additional payment will be made for thickness or width exceeding that shown on the plans.

Item 292

Asphalt Treatment (Plant-Mixed)



1. DESCRIPTION

Construct a base or foundation course composed of a compacted mixture of aggregate and asphalt binder mixed hot in a mixing plant.

2. MATERIALS

Furnish uncontaminated materials of uniform quality that meet the requirements of the plans and specifications. Notify the Engineer of the proposed material sources and of changes to material sources. When a source change occurs, the Engineer will verify that the specification requirements are met and may require a new laboratory mixture design. Use Tex-100-E for material definitions.

- 2.1. **Aggregate.** Furnish aggregates that conform to the requirements shown in Table 1 and specified in this Section unless otherwise shown on the plans. Each source must meet the requirements of Table 1. Stockpile aggregates for each source and type separately. Do not add material to an approved stockpile unless approved by the Engineer. The Engineer may allow testing of the proposed combined aggregates, rather than each source, to meet Table 1 requirements.

Table 1
Aggregate Quality Requirements

Property	Test Method	Specification Requirement
Wet ball mill, % Max	Tex-116-E	50
Max increase, % passing #40		20
Los Angeles abrasion, ¹ % Max	Tex-410-A	50
Liquid limit, Max	Tex-104-E	40
Plasticity index, Max	Tex-106-E	10
Sand equivalent, % Min	Tex-203-F	40
Decantation, ² % Max	Tex-406-A	5.0
Crushed faces, % Min	Tex-460-A	60

1. Use only when shown on the plans, instead of wet ball mill test.
2. Required only for reclaimed asphalt pavement (RAP) stockpiles and recycled aggregates when more than 30% RAP is allowed.

- 2.2. **Recycled Materials.** Use of RAP and RAS is permitted unless otherwise shown on the plans. Do not exceed the maximum allowable percentages of RAP and RAS shown in Table 2. Determine asphalt content and gradation of the RAP and RAS stockpiles for mixture design purposes in accordance with Tex-236-F. The Engineer may verify the asphalt content of the stockpiles at any time during production. Perform other tests on RAP and RAS when shown on the plans. Asphalt binder from RAP and RAS is designated as recycled asphalt binder. When RAP or RAS is used, calculate and ensure that the ratio of the recycled asphalt binder to total binder does not exceed the percentages shown in Table 2 during mixture design and production. During production, use a separate cold feed bin for each stockpile of RAP and RAS.

- 2.2.1. **RAP.** RAP is salvaged, milled, pulverized, broken, or crushed asphalt pavement. Crush or break RAP so that 100% of the particles pass the 2 in. sieve.

Use of Contractor-owned RAP including HMA plant waste is permitted unless otherwise shown on the plans. Department-owned RAP stockpiles are available for the Contractor's use when the stockpile locations are shown on the plans. If Department-owned RAP is available for the Contractor's use, the Contractor may use Contractor-owned fractionated RAP and replace it with an equal quantity of Department-owned RAP.

Department-owned RAP generated through required work on the Contract is available for the Contractor's use when shown on the plans. Perform any necessary tests to ensure Contractor- or Department-owned RAP is appropriate for use. The Department will not perform any tests or assume any liability for the quality of the Department-owned RAP unless otherwise shown on the plans. The Contractor will retain ownership of RAP generated on the project when shown on the plans.

Fractionated RAP is defined as having 2 or more RAP stockpiles, divided into coarse and fine fractions. The coarse RAP stockpile will contain only material retained by processing over a 3/8 in. screen or 1/2 in. screen unless otherwise approved. The fine RAP stockpile will contain only material passing the 3/8 in. screen or 1/2 in. screen unless otherwise approved. The Engineer may allow the Contractor to use an alternate to the 3/8 in. screen or 1/2 in. screen to fractionate the RAP. The maximum percentages of fractionated RAP may be comprised of coarse or fine fractionated RAP or the combination of both coarse and fine fractionated RAP.

Do not use Department- or Contractor-owned RAP contaminated with dirt or other objectionable materials. Do not use Department- or Contractor-owned RAP if the decantation value exceeds 5% and the plasticity index is greater than 8. Test the stockpiled RAP for decantation in accordance with Tex-406-A, Part I. Determine the plasticity index in accordance with Tex-106-E if the decantation value exceeds 5%. The decantation and plasticity index requirements do not apply to RAP samples with asphalt removed by extraction or ignition.

Do not intermingle Contractor-owned RAP stockpiles with Department-owned RAP stockpiles. Remove unused Contractor-owned RAP material from the project site upon completion of the project. Return unused Department-owned RAP to the designated stockpile location.

2.2.2.

RAS. Use of post-manufactured RAS or post-consumer RAS (tear-offs) is permitted unless otherwise shown on the plans. RAS is defined as processed asphalt shingle material from manufacturing of asphalt roofing shingles or from re-roofing residential structures. Post-manufactured RAS is processed manufacturer's shingle scrap by-product. Post-consumer RAS is processed shingle scrap removed from residential structures. Comply with all regulatory requirements stipulated for RAS by the TCEQ. RAS may be used separately or in conjunction with RAP.

Process the RAS by ambient grinding or granulating such that 100% of the particles pass the 3/8 in. sieve when tested in accordance with Tex-200-F, Part I. Perform a sieve analysis on processed RAS material before extraction (or ignition) of the asphalt.

Add sand meeting the requirements of Table 3 and having a maximum linear shrinkage of 3.0% when tested in accordance with Tex-107-E, or fine RAP, to RAS stockpiles if needed to keep the processed material workable. For any stockpile that contains RAS, the entire stockpile will be considered a RAS stockpile and be limited to no more than 3.0% of the mixture in accordance with Table 2.

Certify compliance of the RAS with DMS-11000, "Evaluating and Using Nonhazardous Recyclable Materials (NRM) Guidelines." If the RAS has not come into contact with any hazardous materials, treat it as an established NRM. Use RAS from shingle sources on the Department's MPL. Before use, remove substantially all materials that are not part of the shingle, such as wood, paper, metal, plastic, and felt paper. Determine the deleterious content of RAS material for mixture design purposes in accordance with Tex-217-F, Part III. Do not use RAS if deleterious materials are more than 0.5% of the stockpiled RAS unless otherwise approved. Submit a sample for approval to the Engineer before submitting the mixture design. The Department will perform the testing for deleterious material of RAS to determine specification compliance.

Table 2
Maximum Allowable Amounts of Recycled Binder, RAP, and RAS

Mixture Description & Location	Maximum Ratio of Recycled Binder to Total Binder ¹ (%)	Maximum Allowable Recycled Material (%)		
		Unfractionated RAP ²	Fractionated RAP ³	RAS ⁴
Non-Surface	40.0	20.0	30.0	3.0

1. Combined recycled binder from fractionated RAP and RAS.
2. Do not use in combination with RAS or Fractionated RAP.
3. May replace up to 3.0% fractionated RAP with RAS.
4. May be used separately or as a replacement for no more than 3.0% of the allowable fractionated RAP.

Table 3
Gradation Requirements for Fine Aggregate

Sieve Size	% Passing by Weight or Volume
3/8"	100
#8	70–100
#200	0–30

- 2.3. **Asphalt Material.** Furnish PG64-22 asphalt binder that meets requirements of Item 300, "Asphalts, Oils and Emulsions." When more than 30% RAP is allowed and used, ensure that the new binder and recovered binder from the RAP, when blended proportionally, meet the PG64-22 requirements.

- 2.4. **Tack Coat.** Unless otherwise shown on the plans or as approved, furnish CSS-1H, SS-1H, or a PG binder with a minimum high temperature grade of PG 58 for tack coat binder in accordance with Item 300, "Asphalts, Oils, and Emulsions."

Do not dilute emulsified asphalts at the terminal, in the field, or at any other location before use. If required, verify that emulsified asphalt proposed for use meets the minimum residual asphalt percentage specified in Item 300, "Asphalts, Oils, and Emulsions."

The Engineer will obtain at least one sample of the tack coat binder per project and test to verify compliance with Item 300, "Asphalts, Oils, and Emulsions." The Engineer will obtain the sample from the asphalt distributor immediately before use.

- 2.5. **Additives.** When shown on the plans, use the type and rate of additive specified. Other additives that facilitate mixing or improve the quality of the mix may be allowed when approved.

If lime or a liquid antistripping agent is used, add in accordance with Item 301, "Asphalt Antistripping Agents." Do not add lime directly into the mixing drum of any plant where lime is removed through the exhaust stream unless the plant has a baghouse or dust collection system that reintroduces the fines back into the drum.

3. EQUIPMENT

Provide machinery, tools, and equipment in accordance with Item 320, "Equipment for Asphalt Concrete Pavement."

4. CONSTRUCTION

Produce, haul, place, and compact the specified mixture in accordance with the requirements of this Item.

- 4.1. **Mixture Design.** Using Tex-126-E and the materials proposed for the project, the Engineer will determine the target asphalt content required to produce a mixture meeting the requirements in Table 4 for the grade shown on the plans. The gradation of the combined aggregates will be determined in accordance with Tex-200-F, Part I. Reimburse the Department for subsequent mixture designs or partial designs necessitated by changes in the material or requests by the Contractor. The Engineer may accept a design from the

Contractor that is performed in accordance with Tex-126-E and is submitted on the Department-provided template. Obtain mixture design verification and approval before beginning production.

Table 4
Mix Requirements

Master Gradation Bands				
Tex-200-F, Part I, % Passing by Weight				
Sieve Size	Grade 1	Grade 2	Grade 3	Grade 4
1-3/4"		100	100	As shown on the plans
1-1/2"	100	90-100		
1"	90-100			
3/8"	45-70			
#4	30-55	25-55		
#40	15-30	15-40	15-40	
Asphalt Content, Min(Tex-236-F)				
	4.0%	4.0%	4.0%	4.0%
Strength Requirements (Tex-226-F)				
Indirect tensile strength, (dry) psi ¹	85-200	85-200	85-200	85-200

1. At optimum asphalt content.

The Engineer will evaluate the mixture for moisture susceptibility in accordance with Tex-530-C unless otherwise shown on the plans. A maximum of 10% stripping is allowed unless otherwise shown on the plans. The test sample will be retained and used to establish a baseline for comparison to production results. The Engineer may waive this test if a similar design using the same materials has proven satisfactory.

Produce a trial batch using the proposed project equipment and materials in a large enough quantity to ensure that the mixture is representative of the mixture design. Within one full working day, the Engineer will sample and test the trial batch to ensure that the gradation, asphalt content and strength requirements in Table 4 are met. The Engineer may waive trial mixtures if similar designs have proven satisfactory.

- 4.2. **Production Operations.** Produce a new trial batch when the plant or plant location is changed. Take corrective action and receive approval to proceed after any production suspension for non-compliance to the specification.
- 4.2.1. **Storage and Heating of Materials.** Do not heat the asphalt binder above the temperature specified in Item 300, "Asphalts, Oils, and Emulsions," or outside the manufacturer's recommended values. On a daily basis, provide the Engineer with the records of asphalt binder and hot-mix asphalt discharge temperatures in accordance with Item 320, "Equipment for Asphalt Concrete Pavement." Unless otherwise approved, do not store hot-mix for more than 12 hr. or for a time period less than 12 hr. that affects the quality of the mixture.
- 4.2.2. **Mixing and Discharge of Materials.** Notify the Engineer of the target discharge temperature and produce the mixture within 25°F of the target. When ordinary compaction is used, the Engineer will select a target discharge temperature between 225°F and 350°F. Produce the mixture within 25°F of the target. Monitor the temperature of the material in the truck before shipping to ensure that it does not exceed 350°F. The Department will not pay for or allow placement of any mixture produced at more than 350°F.
- Control the mixing time and temperature so that substantially all moisture is removed from the mixture before discharging from the plant. The Engineer may perform Tex-212-F, Part II, to verify that the mixture contains no more than 0.2% moisture by weight. The sample will be taken immediately after the mixture is discharged into the truck and tested promptly.
- 4.3. **Hauling Operations.** Before use, clean all truck beds to ensure that the mixture will not become contaminated. When a release agent is necessary, use a release agent on the Department's MPL to coat the truck bed.
- 4.4. **Placement Operations.** Prepare the surface by removing objectionable material such as moisture, dirt, sand, leaves and other loose impediments before placing the mixture. Coordinate mixture delivery and paver speed to ensure a continuous placement operation. Suspend placement operations when, in the opinion of

the Engineer, a continuous paving operation is not maintained. Place the mixture to produce a smooth, finished surface with a uniform appearance and texture that meet typical section requirements. Offset longitudinal joints of successive courses of stabilized base by at least 6 in. Place the mix adjacent to gutters and structures so that the pavement will drain properly.

4.4.1. **Weather Conditions.** Tack coat and mixture may be placed only when the roadway surface temperature is 60°F or higher unless otherwise approved. Measure the roadway surface temperature with a handheld infrared thermometer. Place tack coat or mixtures only when the Engineer determines that general weather conditions and moisture conditions of the roadway surface are suitable. The Engineer may waive placement temperature requirements.

4.4.2. **Tack Coat.** Clean the surface before placing the tack coat. Unless otherwise approved, apply tack coat uniformly at a rate between 0.04 and 0.10 gal. of residual asphalt per square yard of surface area. Apply a thin, uniform tack coat to all contact surfaces of curbs, structures, and joints. Prevent splattering of tack coat when placed adjacent to curbs, gutters, and structures. Roll the tack coat with a pneumatic tire roller unless otherwise directed. The Engineer may use Tex-243-F to verify that the tack coat has adequate adhesive properties. The Engineer may suspend paving operations until there is adequate adhesion. The Engineer may waive the requirement to place tack coat.

4.4.3. **Lay-Down Operations.** Dump and spread the asphalt mixture on the approved prepared surface with a spreading and finishing machine. Place the material without tearing, shoving, gouging, or segregating the mixture.

Do not jar or bounce the finishing machine when loading it. Obtain the required lines and grades without hand finishing. The Engineer may authorize hand finishing when the mixture is:

- placed in a narrow strip along the edge of existing pavement,
- used to level small areas, or
- placed in small irregular areas where the use of a finishing machine is not practical.

Leveling courses and other areas may be spread with a motor grader when shown on the plans or approved.

When hot-mix is placed in windrows, operate windrow pick-up equipment so that substantially all the mixture deposited on the roadbed is picked up and loaded into the spreading and finishing machine.

Adjust the hopper flow gates of the spreading and finishing machine to provide an adequate and consistent flow of material. Operate the augers at least 85% of the time. Keep the augers one-half to three-quarters full of mixture. Maintain an adequate flow of material to the center of the paver for the full width of the mat.

Immediately take appropriate corrective action if surface irregularities including but not limited to segregation, rutting, raveling, flushing, fat spots, mat slippage, color, texture, roller marks, tears, gouges, or streaks are detected. Continue placement for no more than one day of production while appropriate action is taken. If no appropriate corrective action is taken or if the problem still exists after one day, suspend paving until the Engineer approves further production.

4.5. **Compaction.** Uniformly compact the pavement to the density requirements of this Item. Use the procedure described in Tex-207-F, Part IV, to establish the rolling pattern. Do not use pneumatic tire rollers if excessive pickup of fines by roller tires occurs.

When using three-wheel, tandem, or vibratory rollers, first roll the joint with the adjacent pavement. Continue rolling longitudinally at the sides, proceeding toward the center of the pavement, and overlap successive trips by at least one foot unless otherwise directed. Make alternate trips of the roller slightly different in length. Begin rolling of superelevated curves at the low side and proceed toward the high side unless otherwise directed.

When operating vibratory rollers:

- do not operate in vibrating mode when stationary;

- do not operate in vibrating mode when changing directions;
- do not operate in vibrating mode on mats with a plan depth of less than 1-1/2 in.;
- do not allow the roller to stand on pavement that has not been fully compacted;
- do not operate when in contact with the compacted, finished pavement structure layer;
- in case of over-vibration resulting in disruption of the compacted material, rework and recompact or replace the damaged material at the Contractor's expense;
- roll at a speed producing at least 10 blows per foot unless otherwise directed;
- keep the drums moist with water without using excess water; and
- do not drop diesel, gasoline, oil, grease, or other foreign matter on the pavement.

Where specific air void requirements are waived, furnish and operate compaction equipment as approved. Use lightly oiled tamps to thoroughly compact the edges of the pavement along curbs, headers, and similar structures and in locations that will not permit thorough compaction with rollers. The Engineer may require rolling with a trench roller on widened areas, in trenches, and in other limited areas.

In-place compaction control is required for all mixtures. Complete all rolling for compaction before the mixture temperature drops below 175°F. Unless otherwise shown on the plans, use density control.

- 4.5.1. **Density Control.** Determine the number and type of rollers needed to obtain the required density. Operate the rollers in accordance with the requirements of this specification and as approved.

Place and compact material to a minimum of 97.0% density as determined by Tex-126-E or as shown on the plans. The Engineer will determine laboratory-molded density in accordance with Tex-126-E from material sampled at the plant. Actual in-place density will be determined in accordance with Tex-126-E unless otherwise directed. Unless otherwise shown on the plans, obtain required roadway specimens as directed. The Engineer will measure air voids in accordance with Tex-207-F. When a satisfactory correlation to results obtained in accordance with Tex-126-E is shown, other methods of determining in-place compaction may be used.

If in-place density is more than 1.0% below minimum density, cease production immediately. If in-place density is between 0.1% and 1.0% below minimum density, investigate the causes and make the necessary corrections. If minimum density is not obtained within one full day of operation, cease production.

Resume production after placing a test section of one lane width and a maximum 0.2 miles long that demonstrates that minimum density can be obtained. Repeat this procedure until producing a test section that meets minimum density requirements. Place no more than 2 test sections per day. Increasing the asphalt content of the mixture to increase in-place density is allowed by approval only.

- 4.5.2. **Ordinary Compaction.** Furnish the type, size and number of rollers required for compaction, as approved or directed. Use at least one pneumatic tire roller. Pneumatic tire rollers will provide a minimum of 80 psi ground contact pressure when used for compaction and a minimum of 55 psi ground contact pressure when used for kneading and sealing the surface.

Establish rolling patterns in accordance with Tex-207-F, Part IV, unless otherwise directed. Follow the selected rolling pattern unless changes in mixture or placement conditions that affect compaction occur. When changes occur, establish a new rolling pattern.

- 4.6. **Sampling and Testing.**

- 4.6.1. **Production Sampling.**

- 4.6.1.1. **Mixture Sampling.** The Engineer will obtain mixture samples in accordance with Tex-222-F.

- 4.6.1.2. **Asphalt Binder Sampling.** The Engineer will obtain at least one 1-quart sample of the asphalt binder used during the project, labeled with date and time, sampled from a port located immediately upstream from the mixing drum or pug mill. The sample will be taken in accordance with Tex-500-C, Part II.
- 4.6.2. **Production Testing.** The Engineer will perform production tests.
- 4.6.2.1. **Operational Tolerances.** The Engineer will determine compliance with operational tolerances. The gradation of the aggregate must be within the master grading limits for the specified grade except that a tolerance of 2% is allowed on the sieve size for each mixture grade that shows 100% passing in Table 2.
- Ensure that the asphalt content does not vary by more than 0.5% from the design target.
- 4.6.2.2. **Individual Loads of Asphalt-Stabilized Base.** The Engineer retains the right to reject individual truckloads of asphalt-stabilized base when it is evident that the material quality is unacceptable. When a load is rejected for reasons other than temperature, the Contractor may request that the rejected load be tested. Make this request within 4 hours of rejection. If Department test results are within the operational tolerances listed in Section 292.4.6.2.1., "Operational Tolerances," payment will be made for the load. If Department test results are not within operational tolerances, no payment will be made for the load.
- 4.6.3. **Placement Sampling and Testing.** Obtain two 6-in. diameter cores side by side at locations selected by the Engineer. Provide the Engineer an opportunity to witness the coring operation and measure the core thickness. Mark the cores for identification. Immediately after obtaining the cores, dry the core holes and tack the sides and bottom. Fill the hole with the same type of mixture and properly compact the mixture. Other methods of repairing the core holes are allowed when approved.
- Trim the cores, if necessary, and deliver them to the Engineer within one working day following placement operations unless otherwise approved.
- 4.6.3.1. **In-Place Air Voids.** The Engineer will measure in-place air voids in accordance with Tex-207-F and Tex-227-F to verify that in-place density requirements of Section 292.4.5.1., "Density Control," are met.
- 4.6.3.2. **Irregularities.** Remove and replace, at the expense of the Contractor and to the satisfaction of the Engineer, any mixture that does not bond to the existing pavement or has other surface irregularities identified by the Engineer.
- 4.6.3.3. **Production Binder Properties.** The Engineer may take cores or other production samples at random from the project to determine recovered asphalt properties. Asphalt binders with an aging ratio greater than 3.5 do not meet requirements for recovered asphalt properties and may be deemed defective when tested and evaluated by the Construction Division. The aging ratio, as determined in accordance with AASHTO T 315, is the DSR value of the extracted binder divided by the DSR value of the original unaged binder. The binder from RAP will be included proportionally as part of the original unaged binder. The Engineer may require the defective material be removed and replaced at the Contractor's expense. The asphalt binder will be recovered for testing from cores in accordance with Tex-211-F.
- 4.7. **Surface Finish.** Use Surface Test Type A in accordance with Item 585, "Ride Quality for Pavement Surfaces," unless otherwise shown on the plans.
- 4.8. **Opening to Traffic.** Open the completed course to traffic when permitted or directed. If the surface ravels, flushes, ruts, or deteriorates in any manner before final acceptance, correct it at the Contractor's expense and to the satisfaction of the Engineer.

5. MEASUREMENT

Asphalt-treated base will be measured by the ton as a composite mixture of asphalt, aggregate, RAP, and additives noted on the plans and approved. Measurement will be made using scales meeting the requirements of Item 520, "Weighing and Measuring Equipment."

6. PAYMENT

The work performed and materials furnished in accordance with this Item and measured as provided under "Measurement" will be paid for at the unit price bid for "Asphalt Stabilized Base" of the grade and binder type specified. This price is full compensation for furnishing and disposing of materials, producing trial batches, loading, hauling, placing, compacting, sampling, testing, replacing defective material, furnishing scales and labor for weighing and measuring, and equipment, labor, tools, and incidentals. State-owned RAP from sources designated on the plans shown to be available will be provided to the Contractor at no cost.

300 Items

Surface Courses and Pavement

This page intentionally left blank

Item 300

Asphalts, Oils, and Emulsions



1. DESCRIPTION

Provide asphalt cements, cutback and emulsified asphalts, performance-graded asphalt binders, and other miscellaneous asphalt materials as specified on the plans.

2. MATERIALS

Provide asphalt materials that meet the stated requirements when tested in accordance with the referenced Department, AASHTO, and ASTM test methods. Use asphalt containing recycled materials only if the recycled components meet the requirements of Article 6.9, "Recycled Materials." Provide asphalt materials that have been preapproved for use by the Construction Division in accordance with Tex-545-C, "Asphalt Binder Quality Program."

Acronyms used in this Item are defined in Table 1.

Table 1
Acronyms

Acronym	Definition
Test Procedure Designations	
Tex	Department
T or R	AASHTO
D	ASTM
Polymer Modifier Designations	
P	polymer-modified
SBR or L	styrene-butadiene rubber (latex)
SBS	styrene-butadiene-styrene block co-polymer
TR	tire rubber (from ambient temperature grinding of truck and passenger tires)
AC	asphalt cement
AE	asphalt emulsion
AE-P	asphalt emulsion prime
A-R	asphalt-rubber
C	cationic
EAP&T	emulsified asphalt prime and tack
H-suffix	harder residue (lower penetration)
HF	high float
MC	medium-curing
MS	medium-setting
PCE	prime, cure, and erosion control
PG	performance grade
RC	rapid-curing
RS	rapid-setting
S-suffix	stockpile usage
SCM	special cutback material
SS	slow-setting

- 2.1. **Asphalt Cement.** Provide asphalt cement that is homogeneous, water-free, and nonfoaming when heated to 347°F, and meets the requirements in Table 2.

Table 2
Asphalt Cement

Property	Test Procedure	Viscosity Grade									
		AC-0.6		AC-1.5		AC-3		AC-5		AC-10	
		Min	Max	Min	Max	Min	Max	Min	Max	Min	Max
Viscosity 140°F, poise 275°F, poise	T 202	40 0.4	80 -	100 0.7	200 -	250 1.1	350 -	400 1.4	600 -	800 1.9	1,200 -
Penetration, 77°F, 100g, 5 sec.	T 49	350	-	250	-	210	-	135	-	85	-
Flash point, C.O.C., °F	T 48	425	-	425	-	425	-	425	-	450	-
Solubility in trichloroethylene, %	T 44	99.0	-	99.0	-	99.0	-	99.0	-	99.0	-
Spot test	Tex-509-C	Neg.		Neg.		Neg.		Neg.		Neg.	
Tests on residue from Thin-Film Oven Test: Viscosity, 140°F, poise Ductility, ¹ 77°F 5 cm/min., cm	T 179 T 202 T 51	- 180 100	- - -	- 450 100	- - -	- 900 100	- - -	- 1,500 100	- - -	- 3,000 100	- - -

1. If AC-0.6 or AC-1.5 ductility at 77°F is less than 100 cm, material is acceptable if ductility at 60°F is more than 100 cm.

- 2.2. **Polymer-Modified Asphalt Cement.** Provide polymer-modified asphalt cement that is smooth, homogeneous, and meets the requirements of Table 3. Supply samples of the base asphalt cement and polymer additives if requested.

Table 3
Polymer-Modified Asphalt Cement

Property	Test Procedure	Polymer-Modified Viscosity Grade											
		AC-5 w/2% SBR		AC-10 w/2% SBR		AC-15P		AC-20XP		AC-10-2TR		AC-20-5TR	
		Min	Max	Min	Max	Min	Max	Min	Max	Min	Max	Min	Max
Polymer		SBR		SBR		SBS		SBS		TR		TR	
Polymer content, % (solids basis)	Tex-533-C	2.0	-	2.0	-	3.0	-	-	-	2.0	-	5.0	-
Dynamic shear, G*/sin δ, 64°C, 10 rad/s, kPa	T 315	-	-	-	-	-	-	1.0	-	-	-	1.0	-
Dynamic shear, G*/sin δ, 58°C, 10 rad/s, kPa	T 315	-	-	-	-	-	-	-	-	1.0	-	-	-
Viscosity 140°F, poise 275°F, poise	T 202 T 202	700 -	- 7.0	1,300 -	- 8.0	1,500 -	- 8.0	2,000 -	- -	1,000 -	- 8.0	2,000 -	- 10.0
Penetration, 77°F, 100 g, 5 sec.	T 49	120	-	80	-	100	150	75	115	95	130	75	115
Ductility, 5cm/min., 39.2°F, cm	T 51	70	-	60	-	-	-	-	-	-	-	-	-
Elastic recovery, 50°F, %	Tex-539-C	-	-	-	-	55	-	55	-	30	-	55	-
Softening point, °F	T 53	-	-	-	-	-	-	120	-	110	-	120	-
Polymer separation, 48 hr.	Tex-540-C	None		None		None		None		None		None	
Flash point, C.O.C., °F	T 48	425	-	425	-	425	-	425	-	425	-	425	-
Tests on residue from RTFOT aging and pressure aging: Creep stiffness S, -18°C, MPa m-value, -18°C	Tex-541-C and R 28 T 313	-	-	-	-	-	300	-	300	-	300	-	300
		-	-	-	-	0.300	-	0.300	-	0.300	-	0.300	-

2.3.

Cutback Asphalt. Provide cutback asphalt that meets the requirements of Tables 4, 5, and 6 for the specified type and grade. Supply samples of the base asphalt cement and polymer additives if requested.

Table 4
Rapid-Curing Cutback Asphalt

Property	Test Procedure	Type-Grade					
		RC-250		RC-800		RC-3000	
		Min	Max	Min	Max	Min	Max
Kinematic viscosity, 140°F, cSt	T 201	250	400	800	1,600	3,000	6,000
Water, %	D95	–	0.2	–	0.2	–	0.2
Flash point, T.O.C., °F	T 79	80	–	80	–	80	–
Distillation test:	T 78						
Distillate, percentage by volume of total distillate to 680°F							
to 437°F		40	75	35	70	20	55
to 500°F		65	90	55	85	45	75
to 600°F		85	–	80	–	70	–
Residue from distillation, volume %		70	–	75	–	82	–
Tests on distillation residue:							
Viscosity, 140°F, poise	T 202	600	2400	600	2400	600	2400
Ductility, 5 cm/min., 77°F, cm	T 51	100	–	100	–	100	–
Solubility in trichloroethylene, %	T 44	99.0	–	99.0	–	99.0	–
Spot test	Tex-509-C		Neg.		Neg.		Neg.

Table 5
Medium-Curing Cutback Asphalt

Property	Test Procedure	Type-Grade							
		MC-30		MC-250		MC-800		MC-3000	
		Min	Max	Min	Max	Min	Max	Min	Max
Kinematic viscosity, 140°F, cSt	T 201	30	60	250	500	800	1,600	3,000	6,000
Water, %	D95	–	0.2	–	0.2	–	0.2	–	0.2
Flash point, T.O.C., °F	T 79	95	–	122	–	140	–	149	–
Distillation test:	T 78								
Distillate, percentage by volume of total distillate to 680°F									
to 437°F		–	35	–	20	–	–	–	–
to 500°F		30	75	5	55	–	40	–	15
to 600°F		75	95	60	90	45	85	15	75
Residue from distillation, volume %		50	–	67	–	75	–	80	–
Tests on distillation residue:									
Viscosity, 140°F, poise	T 202	300	1200	300	1200	300	1200	300	1200
Ductility, 5 cm/min., 77°F, cm	T 51	100	–	100	–	100	–	100	–
Solubility in trichloroethylene, %	T 44	99.0	–	99.0	–	99.0	–	99.0	–
Spot test	Tex-509-C		Neg.		Neg.		Neg.		Neg.

Table 6
Special-Use Cutback Asphalt

Property	Test Procedure	Type-Grade					
		MC-2400L		SCM I		SCM II	
		Min	Max	Min	Max	Min	Max
Kinematic viscosity, 140°F, cSt	T 201	2,400	4,800	500	1,000	1,000	2,000
Water, %	D95	–	0.2	–	0.2	–	0.2
Flash point, T.O.C., °F	T 79	150	–	175	–	175	–
Distillation test:	T 78						
Distillate, percentage by volume of total distillate to 680°F to 437°F		–	–	–	–	–	–
to 500°F		–	35	–	0.5	–	0.5
to 600°F		35	80	20	60	15	50
Residue from distillation, volume %		78	–	76	–	82	–
Tests on distillation residue:							
Polymer		SBR					
Polymer content, % (solids basis)	Tex-533-C	2.0	–	–	–	–	–
Penetration, 100 g, 5 sec., 77°F	T 49	150	300	180	–	180	–
Ductility, 5 cm/min., 39.2°F, cm	T 51	50	–	–	–	–	–
Solubility in trichloroethylene, %	T 44	99.0	–	99.0	–	99.0	–

2.4.

Emulsified Asphalt. Provide emulsified asphalt that is homogeneous, does not separate after thorough mixing, and meets the requirements for the specified type and grade in Tables 7, 8, 9, and 10.

Table 7
Emulsified Asphalt

Property	Test Procedure	Type-Grade									
		Rapid-Setting		Medium-Setting				Slow-Setting			
		HFRS-2		MS-2		AES-300		SS-1		SS-1H	
		Min	Max	Min	Max	Min	Max	Min	Max	Min	Max
Viscosity, Saybolt Furol	T 72										
77°F, sec.		–	–	–	–	75	400	20	100	20	100
122°F, sec.		150	400	100	300	–	–	–	–	–	–
Sieve test, %	T 59	–	0.1	–	0.1	–	0.1	–	0.1	–	0.1
Miscibility	T 59	–		–		–		Pass		Pass	
Cement mixing, %	T 59	–	–	–	–	–	–	–	2.0	–	2.0
Coating ability and water resistance:	T 59										
Dry aggregate/after spray		–	–	–	–	Good/Fair	–	–	–	–	–
Wet aggregate/after spray		–	–	–	–	Fair/Fair	–	–	–	–	–
Demulsibility, 35 ml of 0.02 N CaCl ₂ , %	T 59	50	–	–	30	–	–	–	–	–	–
Storage stability, 1 day, %	T 59	–	1	–	1	–	1	–	1	–	1
Freezing test, 3 cycles ¹	T 59	–		Pass		–		Pass		Pass	
Distillation test:	T 59										
Residue by distillation, % by wt.		65	–	65	–	65	–	60	–	60	–
Oil distillate, % by volume of emulsion		–	0.5	–	0.5	–	5	–	0.5	–	0.5
Tests on residue from distillation:											
Penetration, 77°F, 100 g, 5 sec.	T 49	100	140	120	160	300	–	120	160	70	100
Solubility in trichloroethylene, %	T 44	97.5	–	97.5	–	97.5	–	97.5	–	97.5	–
Ductility, 77°F, 5 cm/min., cm	T 51	100	–	100	–	–	–	100	–	80	–
Float test, 140°F, sec.	T 50	1,200	–	–	–	1,200	–	–	–	–	–

1. Applies only when the Engineer designates material for winter use.

Table 8
Cationic Emulsified Asphalt

Property	Test Procedure	Type-Grade											
		Rapid-Setting				Medium-Setting				Slow-Setting			
		CRS-2		CRS-2H		CMS-2		CMS-2S		CSS-1		CSS-1H	
		Min	Max	Min	Max	Min	Max	Min	Max	Min	Max	Min	Max
Viscosity, Saybolt Furol 77°F, sec.	T 72	-	-	-	-	-	-	-	-	20	100	20	100
		150	400	150	400	100	300	100	300	-	-	-	-
Sieve test, %	T 59	-	0.1	-	0.1	-	0.1	-	0.1	-	0.1	-	0.1
Cement mixing, %	T 59	-	-	-	-	-	-	-	-	-	2.0	-	2.0
Coating ability and water resistance: Dry aggregate/after spray	T 59	-	-	-	-	Good/Fair	Good/Fair	-	-	-	-	-	-
		-	-	-	-	Fair/Fair	Fair/Fair	-	-	-	-	-	-
Wet aggregate/after spray													
Demulsibility, 35 ml of 0.8% Sodium dioctyl sulfosuccinate, %	T 59	70	-	70	-	-	-	-	-	-	-	-	-
Storage stability, 1 day, %	T 59	-	1	-	1	-	1	-	1	-	1	-	1
Particle charge	T 59	Positive		Positive		Positive		Positive		Positive		Positive	
Distillation test: Residue by distillation, % by wt.	T 59	65	-	65	-	65	-	65	-	60	-	60	-
		-	0.5	-	0.5	-	7	-	5	-	0.5	-	0.5
Oil distillate, % by volume of emulsion													
Tests on residue from distillation: Penetration, 77°F, 100 g, 5 sec.	T 49	120	160	70	110	120	200	300	-	120	160	70	110
	T 44	97.5	-	97.5	-	97.5	-	97.5	-	97.5	-	97.5	-
	T 51	100	-	80	-	100	-	-	-	100	-	80	-
Solubility in trichloroethylene, %													
Ductility, 77°F, 5 cm/min., cm													

Table 9
Polymer-Modified Emulsified Asphalt

Property	Test Procedure	Type-Grade											
		Rapid-Setting				Medium-Setting				Slow-Setting			
		RS-1P		HFRS-2P		AES-150P		AES-300P		AES-300S		SS-1P	
		Min	Max	Min	Max	Min	Max	Min	Max	Min	Max	Min	Max
Viscosity, Saybolt Furol 77°F, sec.	T 72	-	-	-	-	75	400	75	400	75	400	30	100
		50	200	150	400	-	-	-	-	-	-	-	-
122°F, sec.													
Sieve test, %	T 59	-	0.1	-	0.1	-	0.1	-	0.1	-	0.1	-	0.1
Miscibility	T 59	-	-	-	-	-	-	-	-	-	-	-	Pass
Coating ability and water resistance: Dry aggregate/after spray	T 59	-	-	-	-	Good/Fair	Good/Fair	Good/Fair	Good/Fair	Good/Fair	Good/Fair	-	-
		-	-	-	-	Fair/Fair	Fair/Fair	Fair/Fair	Fair/Fair	Fair/Fair	Fair/Fair	-	-
Wet aggregate/after spray													
Demulsibility, 35 ml of 0.02 N CaCl ₂ , %	T 59	60	-	50	-	-	-	-	-	-	-	-	-
Storage stability, 1 day, %	T 59	-	1	-	1	-	1	-	1	-	1	-	1
Breaking index, g	Tex-542-C	-	80	-	-	-	-	-	-	-	-	-	-
Distillation test: ¹ Residue by distillation, % by wt.	T 59	65	-	65	-	65	-	65	-	65	-	60	-
		-	3	-	0.5	-	3	-	5	-	7	-	0.5
Oil distillate, % by volume of emulsion													
Tests on residue from distillation: Polymer content, wt. % (solids basis)	Tex-533-C	-	-	3.0	-	-	-	-	-	-	-	3.0	-
	T 49	225	300	90	140	150	300	300	-	300	-	100	140
	T 44	97.0	-	97.0	-	97.0	-	97.0	-	97.0	-	97.0	-
	T 202	-	-	1,500	-	-	-	-	-	-	-	1,300	-
	T 50	-	-	1,200	-	1,200	-	1,200	-	1,200	-	-	-
	T 51	-	-	50	-	-	-	-	-	-	-	50	-
	Tex-539-C	55	-	55	-	-	-	-	-	-	-	-	-
	Elastic recovery, ² 50°F, %												
Tests on RTFO curing of distillation residue	Tex-541-C	-	-	-	-	-	-	-	-	-	-	-	-
	Tex-539-C	-	-	-	-	50	-	50	-	30	-	-	-

- Exception to T 59: Bring the temperature on the lower thermometer slowly to 350°F ±10°F. Maintain at this temperature for 20 min. Complete total distillation in 60 min. (±5 min.) from the first application of heat.
- HFRS-2P must meet one of either the ductility or elastic recovery requirements.

Table 10
Polymer-Modified Cationic Emulsified Asphalt

Property	Test Procedure	Type-Grade											
		Rapid-Setting						Medium-Setting				Slow-Setting	
		CRS-1P		CRS-2P		CHFRS-2P		CMS-1P ³		CMS-2P ³		CSS-1P	
		Min	Max	Min	Max	Min	Max	Min	Max	Min	Max	Min	Max
Viscosity, Saybolt Furol 77°F, sec. 122°F, sec.	T 72	-	-	-	-	-	-	20	100	-	-	20	100
Sieve test, %	T 59	-	0.1	-	0.1	-	0.1	-	0.1	-	0.1	-	0.1
Demulsibility, 35 ml of 0.8% Sodium dioctyl sulfosuccinate, %	T 59	60	-	70	-	60	-	-	-	-	-	-	-
Storage stability, 1 day, %	T 59	-	1	-	1	-	1	-	-	-	-	-	1
Breaking index, g	Tex-542-C	-	80	-	-	-	-	-	-	-	-	-	-
Particle charge	T 59	Positive		Positive		Positive		Positive		Positive		Positive	
Distillation test: ¹ Residue by distillation, % by weight Oil distillate, % by volume of emulsion	T 59	65	-	65	-	65	-	65	-	65	-	62	-
		-	3	-	0.5	-	0.5	-	0.5	-	0.5	-	0.5
Tests on residue from distillation: Polymer content, wt. % (solids basis)	Tex-533-C	-	-	3.0	-	3.0	-	-	-	-	-	3.0	-
Penetration, 77°F, 100 g, 5 sec.	T 49	225	300	90	150	80	130	40	-	40	-	55	90
Viscosity, 140°F, poise	T 202	-	-	1,300	-	1,300	-	-	5,000	-	5,000	-	-
Solubility in trichloroethylene, %	T 44	97.0	-	97.0	-	95.0	-	-	-	-	-	97.0	-
Softening point, °F	T 53	-	-	-	-	130	-	-	-	-	-	135	-
Ductility, 77°F, 5 cm/min., cm	T 51	-	-	-	-	-	-	-	-	-	-	70	-
Float test, 140°F, sec.	T 50	-	-	-	-	1,800	-	-	-	-	-	-	-
Ductility, ² 39.2°F, 5 cm/min., cm	T 51	-	-	50	-	-	-	-	-	-	-	-	-
Elastic recovery, ² 50°F, %	Tex-539-C	45	-	55	-	55	-	45	-	45	-	-	-
Tests on rejuvenating agent: Viscosity, 140°F, cSt	T 201	-	-	-	-	-	-	50	175	50	175	-	-
Flash point, C.O.C., °F	T 48	-	-	-	-	-	-	380	-	380	-	-	-
Saturates, % by weight	D2007	-	-	-	-	-	-	-	30	-	30	-	-
Solubility in n-pentane, % by weight	D2007	-	-	-	-	-	-	99	-	99	-	-	-
Tests on rejuvenating agent after TFO or RTFO: Weight Change, %	T 240 or T 179	-	-	-	-	-	-	-	6.5	-	6.5	-	-
Viscosity Ratio		-	-	-	-	-	-	-	3.0	-	3.0	-	-
Tests on latex: ⁴ Tensile strength, die C dumbbell, psi	D412 ⁵	-	-	-	-	-	-	500	-	500	-	-	-
Change in mass after immersion in rejuvenating agent, %	D471	-	-	-	-	-	-	-	40 ⁶	-	40 ⁶	-	-

- Exception to T 59: Bring the temperature on the lower thermometer slowly to 350°F (±0°F). Maintain at this temperature for 20 min. Complete total distillation in 60 min. (±5 min.) from the first application of heat.
- CRS-2P must meet one of either the ductility or elastic recovery requirements.
- With all precertification samples of CMS-1P or CMS-2P, submit certified test reports showing that the rejuvenating agent and latex meet the stated requirements. Submit samples of these raw materials if requested by the Engineer.
- Preparation of latex films: Use any substrate which produces a film of uniform cross-section. Apply latex using a drawdown tool that will deliver enough material to achieve desired residual thickness. Cure films for 14 days at 75°F and 50% relative humidity.
- Cut samples for tensile strength determination using a crosshead speed of 20 in./min.
- Specimen must remain intact after exposure and removal of excess rejuvenating agent.

- 2.5. **Specialty Emulsions.** Provide specialty emulsion that is either asphalt-based or resin-based and meets the requirements of Table 11.

Table 11
Specialty Emulsions

Property	Test Procedure	Type-Grade					
		Medium-Setting				Slow-Setting	
		AE-P		EAP&T		PCE ¹	
		Min	Max	Min	Max	Min	Max
Viscosity, Saybolt Furol 77°F, sec. 122°F, sec.	T 72	– 15	– 150	– –	– –	10 –	100 –
Sieve test, %	T 59	–	0.1	–	0.1	–	0.1
Miscibility ²	T 59	–	–	Pass	–	Pass	–
Demulsibility, 35 ml of 0.10 N CaCl ₂ , %	T 59	–	70	–	–	–	–
Storage stability, 1 day, %	T 59	–	1	–	1	–	–
Particle size, ⁵ % by volume < 2.5 μm	Tex-238-F ³	–	–	90	–	90	–
Asphalt emulsion distillation to 500°F followed by Cutback asphalt distillation of residue to 680°F: Residue after both distillations, % by wt. Total oil distillate from both distillations, % by volume of emulsion	T 59 & T 78	40 25	– 40	– –	– –	– –	– –
Residue by distillation, % by wt.	T 59	–	–	60	–	–	–
Residue by evaporation, ⁴ % by wt.	T 59	–	–	–	–	60	–
Tests on residue after all distillation(s): Viscosity, 140°F, poise Kinematic viscosity, ⁵ 140°F, cSt Flash point C.O.C., °F Solubility in trichloroethylene, % Float test, 122°F, sec.	T 202 T 201 T 48 T 44 T 50	– – – 97.5 50	– – – – 200	800 – – – –	– – – – –	– 100 400 – –	– 350 – – –

Supply with each shipment of PCE:

- a copy of a lab report from an approved analytical lab, signed by a lab official, indicating the PCE formulation does not meet any characteristics of a Resource Conservation Recovery Act (RCRA) hazardous waste;
- a certification from the producer that the formulation supplied does not differ from the one tested and that no listed RCRA hazardous wastes or Polychlorinated Biphenyls (PCBs) have been mixed with the product; and
- a Material Safety Data Sheet.

Exception to T 59: In dilution, use 350 ml of distilled or deionized water and a 1,000-ml beaker.

Use Tex-238-F, beginning at "Particle Size Analysis by Laser Diffraction," with distilled or deionized water as a medium and no dispersant, or use another approved method.

Exception to T 59: Leave sample in the oven until foaming ceases, then cool and weigh.

PCE must meet either the kinematic viscosity requirement or the particle size requirement.

- 2.6. **Recycling Agent.** Recycling agent and emulsified recycling agent must meet the requirements in Table 12. Additionally, recycling agent and residue from emulsified recycling agent, when added in the specified proportions to the recycled asphalt, must meet the properties specified on the plans.

Table 12
Recycling Agent and Emulsified Recycling Agent

Property	Test Procedure	Recycling Agent		Emulsified Recycling Agent	
		Min	Max	Min	Max
Viscosity, Saybolt Furol, 77°F, sec.	T 72	–	–	15	100
Sieve test, %	T 59	–	–	–	0.1
Miscibility ¹	T 59	–		No coagulation	
Residue by evaporation, ² % by wt.	T 59	–	–	60	–
Tests on recycling agent or residue from evaporation:	T 48 T 201				
Flash point, C.O.C., °F		400	–	400	–
Kinematic viscosity, 140°F, cSt		75	200	75	200
275°F, cSt		–	10.0	–	10.0

- Exception to T 59: Use 0.02 N CaCl₂ solution in place of water.
- Exception to T 59: Maintain sample at 300°F until foaming ceases, then cool and weigh.

2.7. **Crumb Rubber Modifier.** Crumb rubber modifier (CRM) consists of automobile and truck tires processed by ambient temperature grinding.

CRM must be:

- free from contaminants including fabric, metal, and mineral and other nonrubber substances;
- free-flowing; and
- nonfoaming when added to hot asphalt binder.

Ensure rubber gradation meets the requirements of the grades in Table 13 when tested in accordance with Tex-200-F, Part I, using a 50-g sample.

Table 13
CRM Gradations

Sieve Size (% Passing)	Grade A		Grade B		Grade C		Grade D	Grade E
	Min	Max	Min	Max	Min	Max		
#8	100	–	–	–	–	–	As shown on the plans	As approved
#10	95	100	100	–	–	–		
#16	–	–	70	100	100	–		
#30	–	–	25	60	90	100		
#40	–	–	–	–	45	100		
#50	0	10	–	–	–	–		
#200	–	–	0	5	–	–		

2.8. **Crack Sealer.** Provide polymer-modified asphalt-emulsion crack sealer meeting the requirements of Table 14. Provide rubber-asphalt crack sealer meeting the requirements of Table 15.

Table 14
Polymer-Modified Asphalt-Emulsion Crack Sealer

Property	Test Procedure	Min	Max
Rotational viscosity, 77°F, cP	D2196, Method A	10,000	25,000
Sieve test, %	T 59	–	0.1
Storage stability, 1 day, %	T 59	–	1
Evaporation Residue by evaporation, % by wt.	Tex-543-C	65	–
Tests on residue from evaporation:			
Penetration, 77°F, 100 g, 5 sec.	T 49	35	75
Softening point, °F	T 53	140	–
Ductility, 39.2°F, 5 cm/min., cm	T 51	100	–

Table 15
Rubber-Asphalt Crack Sealer

Property	Test Procedure	Class A		Class B	
		Min	Max	Min	Max
CRM content, Grade A or B, % by wt.	Tex-544-C	22	26	–	–
CRM content, Grade B, % by wt.	Tex-544-C	–	–	13	17
Virgin rubber content, ¹ % by wt.		–	–	2	–
Flash point, ² C.O.C., °F	T 48	400	–	400	–
Penetration, ³ 77°F, 150 g, 5 sec.	T 49	30	50	30	50
Penetration, ³ 32°F, 200 g, 60 sec.	T 49	12	–	12	–
Softening point, °F	T 53	–	–	170	–
Bond Test, non-immersed, 0.5 in specimen, 50% extension, 20°F ⁴	D5329	–		Pass	

1. Provide certification that the Min % virgin rubber was added.
2. Agitate the sealing compound with a 3/8- to 1/2-in. (9.5- to 12.7-mm) wide, square-end metal spatula to bring the material on the bottom of the cup to the surface (i.e., turn the material over) before passing the test flame over the cup. Start at one side of the thermometer, move around to the other, and then return to the starting point using 8 to 10 rapid circular strokes. Accomplish agitation in 3 to 4 sec. Pass the test flame over the cup immediately after stirring is completed.
3. Exception to T 49: Substitute the cone specified in D217 for the penetration needle.
4. Allow no crack in the crack sealing materials or break in the bond between the sealer and the mortar blocks over 1/4 in. deep for any specimen after completion of the test.

- 2.9. **Asphalt-Rubber Binders.** Provide asphalt-rubber (A-R) binders that are mixtures of asphalt binder and CRM, which have been reacted at elevated temperatures. Provide A-R binders meeting D6114 and containing a minimum of 15% CRM by weight. Provide Types I or II, containing CRM Grade C, for use in hot-mixed aggregate mixtures. Provide Types II or III, containing CRM Grade B, for use in surface treatment binder. Ensure binder properties meet the requirements of Table 16.

Table 16
A-R Binders

Property	Test Procedure	Binder Type					
		Type I		Type II		Type III	
		Min	Max	Min	Max	Min	Max
Apparent viscosity, 347°F, cP	D2196, Method A	1,500	5,000	1,500	5,000	1,500	5,000
Penetration, 77°F, 100 g, 5 sec.	T 49	25	75	25	75	50	100
Penetration, 39.2°F, 200 g, 60 sec.	T 49	10	–	15	–	25	–
Softening point, °F	T 53	135	–	130	–	125	–
Resilience, 77°F, %	D5329	25	–	20	–	10	–
Flash point, C.O.C., °F	T 48	450	–	450	–	450	–
Tests on residue from Thin-Film Oven Test:	T 179						
Retained penetration ratio, 39.2°F, 200 g, 60 sec., % of original	T 49	75	–	75	–	75	–

- 2.10. **Performance-Graded Binders.** Provide PG binders that are smooth and homogeneous, show no separation when tested in accordance with Tex-540-C, and meet the requirements of Table 17.

Separation testing is not required if:

- a modifier is introduced separately at the mix plant either by injection in the asphalt line or mixer,
- the binder is blended on site in continuously agitated tanks, or
- binder acceptance is based on field samples taken from an in-line sampling port at the hot-mix plant after the addition of modifiers.

Table 17
Performance-Graded Binders

Property and Test Method	Performance Grade																	
	PG 58			PG 64			PG 70			PG 76			PG 82					
	-22	-28	-34	-16	-22	-28	-34	-16	-22	-28	-34	-16	-22	-28	-34	-16	-22	-28
Average 7-day max pavement design temperature, °C ¹	< 58			< 64			< 70			< 76			< 82					
Min pavement design temperature, °C ¹	>-22	>-28	>-34	>-16	>-22	>-28	>-34	>-16	>-22	>-28	>-34	>-16	>-22	>-28	>-34	>-16	>-22	>-28
Original Binder																		
Flash point, T 48, Min, °C	230																	
Viscosity, T 316: ^{2,3} Max, 3.0 Pa-s, test temperature, °C	135																	
Dynamic shear, T 315: ⁴ G*/sin(δ), Min, 1.00 kPa, Max, 2.00 kPa, ⁷ Test temperature @ 10 rad/sec., °C	58			64			70			76			82					
Elastic recovery, D6084, 50°F, % Min	-	-	30	-	-	30	50	-	30	50	60	30	50	60	70	50	60	70
Rolling Thin-Film Oven (Tex-541-C)																		
Mass loss, Tex-541-C, Max, %	1.0																	
Dynamic shear, T 315: G*/sin(δ), Min, 2.20 kPa, Max, 5.00 kPa, ⁷ Test temperature @ 10 rad/sec., °C	58			64			70			76			82					
Pressure Aging Vessel (PAV) Residue (R 28)																		
PAV aging temperature, °C	100																	
Dynamic shear, T 315: G*/sin(δ), Max, 5,000 kPa Test temperature @ 10 rad/sec., °C	25	22	19	28	25	22	19	28	25	22	19	28	25	22	19	28	25	22
Creep stiffness, T 313: ^{5,6} S, max, 300 MPa, m-value, Min, 0.300 Test temperature @ 60 sec., °C	-12	-18	-24	-6	-12	-18	-24	-6	-12	-18	-24	-6	-12	-18	-24	-6	-12	-18
Direct tension, T 314: ⁶ Failure strain, Min, 1.0% Test temperature @ 1.0 mm/min., °C	-12	-18	-24	-6	-12	-18	-24	-6	-12	-18	-24	-6	-12	-18	-24	-6	-12	-18

- Pavement temperatures are estimated from air temperatures using an algorithm contained in a Department-supplied computer program, may be provided by the Department, or by following the procedures outlined in AASHTO MP 2 and PP 28.
- This requirement may be waived at the Department's discretion if the supplier warrants that the asphalt binder can be adequately pumped, mixed, and compacted at temperatures that meet all applicable safety, environmental, and constructability requirements. At test temperatures where the binder is a Newtonian fluid, any suitable standard means of viscosity measurement may be used, including capillary (T 201 or T 202) or rotational viscometry (T 316).
- Viscosity at 135°C is an indicator of mixing and compaction temperatures that can be expected in the lab and field. High values may indicate high mixing and compaction temperatures. Additionally, significant variation can occur from batch to batch. Contractors should be aware that variation could significantly impact their mixing and compaction operations. Contractors are therefore responsible for addressing any constructability issues that may arise.
- For quality control of unmodified asphalt binder production, measurement of the viscosity of the original asphalt binder may be substituted for dynamic shear measurements of G*/sin(δ) at test temperatures where the asphalt is a Newtonian fluid. Any suitable standard means of viscosity measurement may be used, including capillary (T 201 or T 202) or rotational viscometry (T 316).
- Silicone beam molds, as described in AASHTO TP 1-93, are acceptable for use.
- If creep stiffness is below 300 MPa, direct tension test is not required. If creep stiffness is between 300 and 600 MPa, the direct tension failure strain requirement can be used instead of the creep stiffness requirement. The m-value requirement must be satisfied in both cases.
- Maximum values for unaged and RTFO aged dynamic shear apply only to materials used as substitute binders, as described in specification items, 340, "Dense-Graded Hot-Mix Asphalt (Small Quantity)," 341, "Dense-Graded Hot-Mix Asphalt," and 344, "Superpave Mixtures."

3. EQUIPMENT

Provide all equipment necessary to transport, store, sample, heat, apply, and incorporate asphalts, oils, and emulsions.

4. CONSTRUCTION

Typical Material Use. Use materials shown in Table 18, unless otherwise determined by the Engineer.

Table 18
Typical Material Use

Material Application	Typically Used Materials
Hot-mixed, hot-laid asphalt mixtures	PG binders, A-R binders Types I and II
Surface treatment	AC-5, AC-10, AC-5 w/2% SBR, AC-10 w/2% SBR, AC-15P, AC-20XP, AC-10-2TR, AC-20-5TR, HFRS-2, MS-2, CRS-2, CRS-2H, HFRS-2P, CRS-2P, CHFRS-2P, A-R binders Types II and III
Surface treatment (cool weather)	RS-1P, CRS-1P, RC-250, RC-800, RC-3000, MC-250, MC-800, MC-3000, MC-2400L
Precoating	AC-5, AC-10, PG 64-22, SS-1, SS-1H, CSS-1, CSS-1H
Tack coat	PG Binders, SS-1H, CSS-1H, EAP&T
Fog seal	SS-1, SS-1H, CSS-1, CSS-1H
Hot-mixed, cold-laid asphalt mixtures	AC-0.6, AC-1.5, AC-3, AES-300, AES-300P, CMS-2, CMS-2S
Patching mix	MC-800, SCM I, SCM II, AES-300S
Recycling	AC-0.6, AC-1.5, AC-3, AES-150P, AES-300P, recycling agent, emulsified recycling agent
Crack sealing	SS-1P, polymer mod AE crack sealant, rubber asphalt crack sealers (Class A, Class B)
Microsurfacing	CSS-1P
Prime	MC-30, AE-P, EAP&T, PCE
Curing membrane	SS-1, SS-1H, CSS-1, CSS-1H, PCE
Erosion control	SS-1, SS-1H, CSS-1, CSS-1H, PCE

4.1.

Storage and Application Temperatures. Use storage and application temperatures in accordance with Table 19. Store and apply materials at the lowest temperature yielding satisfactory results. Follow the manufacturer's instructions for any agitation requirements in storage. Manufacturer's instructions regarding recommended application and storage temperatures supersede those of Table 19.

Table 19
Storage and Application Temperatures

Type-Grade	Application		Storage Maximum (°F)
	Recommended Range (°F)	Maximum Allowable (°F)	
AC-0.6, AC-1.5, AC-3	200–300	350	350
AC-5, AC-10	275–350	350	350
AC-5 w/2% SBR, AC-10 w/2% SBR, AC-15P, AC-20-5TR	300–375	375	360
RC-250	125–180	200	200
RC-800	170–230	260	260
RC-3000	215–275	285	285
MC-30, AE-P	70–150	175	175
MC-250	125–210	240	240
MC-800, SCM I, SCM II	175–260	275	275
MC-3000, MC-2400L	225–275	290	290
HFRS-2, MS-2, CRS-2, CRS-2H, HFRS-2P, CRS-2P, CMS-2, CMS-2S, AES-300, AES-300S, AES-150P, AES-300P	120–160	180	180
SS-1, SS-1H, CSS-1, CSS-1H, PCE, EAP&T, SS-1P, RS-1P, CRS-1P, CSS-1P, recycling agent, emulsified recycling agent, polymer mod AE crack sealant	50–130	140	140
PG binders	275–350	350	350
Rubber asphalt crack sealers (Class A, Class B)	350–375	400	–
A-R binders Types I, II, and III	325–425	425	425

5. MEASUREMENT AND PAYMENT

The work performed, materials furnished, equipment, labor, tools, and incidentals will not be measured or paid for directly but is subsidiary or is included in payment for other pertinent items.

Item 301

Asphalt Antistripping Agents



1. DESCRIPTION

Furnish and incorporate all required asphalt antistripping agents in asphalt concrete paving mixtures and asphalt-stabilized base mixtures to meet moisture resistance testing requirements.

2. MATERIALS

2.1. **Lime.** Provide hydrated lime or commercial lime slurry in accordance with DMS-6350, "Lime and Lime Slurry."

2.2. **Liquid Antistripping Agent.** Provide a liquid antistripping agent that is uniform and shows no evidence of crystallization, settling, or separation.

Ensure all liquid antistripping agents arrive in:

- properly labeled and unopened containers, as shipped from the manufacturer, or
- sealed tank trucks with an invoice to show contents and quantities.

Provide product information to the Engineer including:

- material safety data sheet,
- specific gravity of the agent at the manufacturer's recommended addition temperature,
- manufacturer's recommended dosage range, and
- handling and storage instructions.

3. EQUIPMENT

Provide all equipment to store, handle, dispense, meter, and mix asphalt antistripping agents.

4. CONSTRUCTION

4.1. **Laboratory Design Evaluation and Production Mixture Verification.** Provide a laboratory mixture design and production mixture that meet moisture resistance requirements. Evaluate proposed asphalt pavement or base mixtures during design and production according to the moisture resistance requirements in the asphalt mixture specification.

Governing specifications require the Contractor or Engineer to design the mixture, and the party performing the design is responsible for the moisture susceptibility evaluation. If the Contractor designs the mixture, the Engineer verifies compliance.

Determine the dosage needed to achieve the moisture resistance requirements during design if an antistripping agent is required. Use this addition rate in the production mixture.

Add between 0.5% and 2.0% of hydrated lime or commercial lime slurry solids by weight of the individual aggregate treated when using lime.

Add liquid antistripping agent, when used, to the binder, in accordance with the manufacturer's instructions. Do not exceed the manufacturer's maximum recommended dosage rate.

Stop production if the production mixture does not meet moisture resistance requirements and correct the problem.

- 4.2. **Addition of Antistripping Agents at the Mix Plant.** Connect the measuring device for the addition of the asphalt antistripping agent into the automatic plant controls to automatically adjust the supply to plant production and provide a consistent percentage in the mixture. Set automatic plant controls so that an interruption of asphalt antistripping agent's flow causes plant shutdown.
- 4.2.1. **Lime.** Incorporate lime in a manner that thoroughly and uniformly distributes lime onto the aggregate surface or into the mixture. Use metering equipment, as approved, to ensure the required quantity of lime is used.
- 4.2.1.1. **Hydrated Lime.** Add hydrated lime to the aggregate by one of the following methods, unless otherwise shown on the plans:
- Mix in an approved pug mill mixer with damp aggregate containing water at least 2% above saturated surface dry conditions.
 - Add into the drum-mix plant immediately before asphalt binder addition or in the pug mill of the weigh-batch plant before asphalt binder addition. Dry mix aggregates and lime before adding asphalt binder when a weigh batch plant is used.
- 4.2.1.2. **Commercial Lime Slurry.** Add commercial lime slurry to the aggregate by one of the following methods unless otherwise shown on the plans:
- Mix in a suitable pug mill mixer with the aggregate.
 - Mix with aggregate between the plant cold feeds and the dryer or mixing drum during mixture production.
- 4.2.2. **Liquid Antistripping Agent.** Incorporate liquid antistripping agent into the binder as follows:
- Handle in accordance with the manufacturer's recommendations.
 - Add at the manufacturer's recommended addition temperature.
 - Add into the asphalt line by means of an in-line-metering device, in accordance with Item 520, "Weighing and Measuring Equipment," and a blending device to disperse the agent.
 - Place the metering and blending devices in an approved location.

5. MEASUREMENT AND PAYMENT

The work performed, materials furnished, equipment, labor, tools, and incidentals will not be measured or paid for directly but is subsidiary or is included in payment quantity for other pertinent Items.

Item 302

Aggregates for Surface Treatments



1. DESCRIPTION

Furnish aggregate for surface treatments in conformance to the type, grade, and Surface Aggregate Classification (SAC) shown on the plans.

2. MATERIALS

Furnish uncontaminated materials of uniform quality throughout that meet the requirements of the plans and specifications. Notify the Engineer of all proposed material sources and of changes to material sources. The Engineer will designate the sampling location.

- 2.1. **Aggregate.** Stockpile aggregates for each source and type separately. Do not add materials to approved stockpiles without the approval of the Engineer.

Furnish aggregate of the type shown on the plans and listed in Table 1. Use Tex-100-E material definitions.

Table 1
Aggregate Types

Type	Material
A	Gravel, crushed slag, crushed stone, or limestone rock asphalt (LRA)
B	Crushed gravel, crushed slag, crushed stone, or LRA
C	Gravel, crushed slag, or crushed stone
D	Crushed gravel, crushed slag, or crushed stone
E	Aggregate as shown on the plans
L	Lightweight Aggregate
PA	Precoated gravel, crushed slag, crushed stone, or LRA
PB	Precoated crushed gravel, crushed slag, crushed stone, or LRA
PC	Precoated gravel, crushed slag, or crushed stone
PD	Precoated crushed gravel, crushed slag, crushed stone
PE	Precoated aggregate as shown on the plans
PL	Precoated lightweight aggregate

Ensure the aggregate gradation meets the requirements in Table 2 for the specified grade, unless otherwise approved.

Furnish aggregate that meets the requirements shown in Table 3, unless otherwise shown on the plans. Furnish LRA in accordance with DMS-9210, "Limestone Rock Asphalt (LRA)," when used. Provide aggregates from sources listed in the Department's *Bituminous Rated Source Quality Catalog (BRSQC)*. Use material not listed or not meeting the requirements of the BRSQC only when tested by the Engineer and approved before use. Allow 30 calendar days for testing of material from such sources.

Provide aggregates for final surfaces that meet the SAC shown on the plans. Do not blend to meet the SAC. The SAC requirement will apply only to the aggregate used on the travel lanes unless otherwise shown on the plans. The BRSQC lists the SAC for sources on the *Aggregate Quality Monitoring Program (AQMP)*.

Table 2
Aggregate Gradation Requirements (Cumulative % Retained¹)

Sieve	Grade								
	1	2	3S ²	3		4S ²	4	5S ²	5
				Non-Lightweight	Lightweight				
1"	-	-	-	-	-	-	-	-	-
7/8"	0-2	0	-	-	-	-	-	-	-
3/4"	20-35	0-2	0	0	0	-	-	-	-
5/8"	85-100	20-40	0-5	0-5	0-2	0	0	-	-
1/2"	-	80-100	55-85	20-40	10-25	0-5	0-5	0	0
3/8"	95-100	95-100	95-100	80-100	60-80	60-85	20-40	0-5	0-5
1/4"	-	-	-	95-100	95-100	-	-	65-85	-
#4	-	-	-	-	-	95-100	95-100	95-100	50-80
#8	99-100	99-100	99-100	99-100	98-100	98-100	98-100	98-100	98-100

1. Round test results to the nearest whole number.
2. Single-size gradation.

Table 3
Aggregate Requirements

Property	Test Method	Requirement	Remarks
Sampling	Tex-221-F	-	
SAC	AQMP	As shown on the plans	
Deleterious Material, %, Max	Tex-217-F, Part I	2.0	Not required for lightweight aggregate.
Decantation, %, Max	Tex-406-A	1.5	
Flakiness Index, Max	Tex-224-F	17	Unless otherwise shown on the plans.
Gradation	Tex-200-F, Part I	See Table 2	
Los Angeles Abrasion, %, Max	Tex-410-A	35	
Magnesium Sulfate Soundness, 5 Cycle, %, Max	Tex-411-A	25	
Micro-Deval Abrasion, %, Max	Tex-461-A	-	Not used for acceptance purposes. Used by the Engineer as an indicator for further investigation.
Coarse Aggregate Angularity, 2 Crushed Faces, %, Min	Tex-460-A, Part I	85	Unless otherwise shown on the plans. Only required for crushed gravel
Additional Requirements for Lightweight Aggregate			
Dry Loose Unit Wt., lb./cu. ft.	Tex-404-A	35-60	
Pressure Slaking, %, Max	Tex-431-A	6.0	
Freeze-Thaw Loss, %, Max	Tex-432-A	10.0	
Water Absorption, 24 ^o hr., %, Max	Tex-433-A	12.0	Unless otherwise shown on the plans.

- 2.2. **Precoating.** Precoat aggregate uniformly and adequately with asphalt material to the satisfaction of the Engineer when shown on the plans. Specific aggregates may be prohibited from being precoated when shown on the plans. Meet Table 2 and Table 3 requirements before precoating. Furnish precoated aggregate that spreads uniformly using approved mechanical spreading equipment.

The Engineer retains the right to select a target value for the desired percent by weight of residual bitumen coating on the aggregate. Furnish precoated aggregate that is within $\pm 0.3\%$ of the target value when tested in accordance with Tex-236-F. The Engineer may require trial batches to assist in selecting the target value.

The Engineer retains the right to remove precoat material from aggregate samples in accordance with Tex-236-F and test the aggregate to verify compliance with Table 2 and Table 3 requirements. Gradation testing may be performed with precoat intact.

- 2.2.1. **Asphalt Material.** Precoat the aggregates with asphalt material that meets the requirements of Item 300, "Asphalts, Oils, and Emulsions." Use any asphalt material that meets the requirements of Item 300, "Asphalts, Oils, and Emulsions," unless a specific precoat material is specified on the plans.

- 2.2.2. **Additives.** Use the type and rate of additive specified when shown on the plans. Add in accordance with Item 301, "Asphalt Antistripping Agents." Use Tex-530-C for verification during production testing unless otherwise directed.

3. EQUIPMENT

Manufacture precoated aggregate in a mixing plant that produces uniformly coated aggregate.

4. CONSTRUCTION

Deliver aggregate to the locations shown on the plans. Prevent segregation, mixing of the various materials or sizes, and contamination with foreign materials when aggregates are stockpiled. The Engineer will reject contaminated stockpiles.

Provide adequate initial cooling of precoated aggregate to prevent asphalt or aggregate damage due to excessive heat buildup in stockpiles. Limit stockpile height to 3 ft. immediately after production when asphalt cement is the precoating material. Consolidate stockpiles after adequate cooling, as approved. The Engineer will reject stockpiles showing evidence of damage due to excessive heat buildup.

5. MEASUREMENT AND PAYMENT

The work performed, materials furnished, equipment, tools, and incidentals will not be measured or paid for directly but is subsidiary to or included under "Payment" in other pertinent Items.

Item 305

Salvaging, Hauling, and Stockpiling Reclaimable Asphalt Pavement



1. DESCRIPTION

Salvage, haul, and stockpile existing asphalt material.

2. CONSTRUCTION

Remove dirt, raised pavement markings, and other debris, as directed. Remove the reclaimable asphalt material as shown on the plans or as directed. Ensure that 95% of the reclaimed material passes a 2 in. sieve unless otherwise shown on the plans. Do not contaminate asphalt material during its removal, transportation, or storage. Repair remaining pavement that is damaged by the removal operations.

Provide a clean, smooth, and well-drained stockpile area free of trash, weeds, and grass. Separate different types or quality of asphalt material into different stockpiles as directed. Stockpile material as shown on the plans or as directed.

The Department retains ownership of the reclaimed asphalt material unless otherwise shown on the plans. The plans or the Engineer may allow or require the use of salvaged material for other items in the Contract. Stockpile the salvaged material at the location shown on the plans or as directed if not used in other construction items of this Contract.

3. MEASUREMENT

This Item will be measured by the cubic yard of material calculated by the average end area method in the stockpile, or the square yard in its original position.

4. PAYMENT

The work performed and materials furnished in accordance with this Item and measured as provided under "Measurement" will be paid for at the unit price bid for "Salvaging, Hauling, and Stockpiling Reclaimable Asphalt Pavement" for cubic yard measurement, and for "Salvaging, Hauling, and Stockpiling Reclaimable Asphalt Pavement (Depth Specified)" for square yard measurement. This price is full compensation for cleaning and removing existing pavement; stockpile area preparation; loading, crushing or breaking, hauling, and stockpiling material; and material, equipment, labor, tools, supplies, and incidentals.

Item 310

Prime Coat



1. DESCRIPTION

Prepare and treat existing or newly constructed surface with an asphalt binder or other specialty prime coat binder material. Apply blotter material as required.

2. MATERIALS

- 2.1. **Binder.** Use material of the type and grade shown on the plans in accordance with Item 300, "Asphalts, Oils, and Emulsions," or as listed in the Department's MPL for prime coat binders.
- 2.2. **Blotter.** Use either base course sweepings obtained from cleaning the base or native sand as blotter materials unless otherwise shown on the plans or approved.

3. EQUIPMENT

Provide applicable equipment in accordance with Article 316.3., "Equipment."

4. CONSTRUCTION

- 4.1. **General.** Apply the mixture when the air temperature is at or above 60°F, or above 50°F and rising. Measure the air temperature in the shade away from artificial heat. The Engineer will determine when weather conditions are suitable for application.
- Do not permit traffic, hauling, or placement of subsequent courses over freshly constructed prime coats. Maintain the primed surface until placement of subsequent courses or acceptance of the work.
- 4.2. **Surface Preparation.** Prepare the surface by sweeping or other approved methods. Lightly sprinkle the surface with water before applying bituminous material, when directed, to control dust and ensure absorption.
- 4.3. **Application.**
- 4.3.1. **Binder.** The Engineer will select the application temperature within the limits recommended in Item 300, "Asphalts, Oils, and Emulsions," or by the material manufacturer. Apply material within 15°F of the selected temperature but do not exceed the maximum allowable temperature.
- Distribute the material smoothly and evenly at the rate selected by the Engineer. Roll the freshly applied prime coat with a pneumatic-tire roller to ensure penetration when directed.
- 4.3.2. **Blotter.** Spread blotter material before allowing traffic to use a primed surface. Apply blotter material to primed surface at the specified rate when "Prime Coat and Blotter" is shown on the plans as a bid item or as directed. Apply blotter to spot locations when "Prime Coat" is shown on the plans as a bid item or as directed to accommodate traffic movement through the work area. Remove blotter material before placing the surface. Dispose of blotter material according to applicable state and federal requirements.

5. MEASUREMENT

This Item will be measured by the gallon of binder placed and accepted.

6. PAYMENT

The work performed and materials furnished in accordance with this Item and measured as provided under "Measurement" will be paid for at the unit price bid for "Prime Coat" or "Prime Coat and Blotter" of the type and grade of binder specified. This price is full compensation for cleaning and sprinkling the area to be primed; materials, including blotter material; and rolling, equipment, labor, tools, and incidentals.

Item 314

Emulsified Asphalt Treatment



1. DESCRIPTION

Apply an emulsified asphalt and water mixture as a base or subgrade treatment; for erosion control, including dust prevention; or as a prime coat.

2. MATERIALS

Furnish materials in accordance with the following.

- Item 204, "Sprinkling," and
- Item 300, "Asphalts, Oils, and Emulsions."

Use emulsified asphalt of the type and grade shown on the plans. Use a quantity of emulsified asphalt in the mixture, expressed as a percent of total volume, in accordance with the percentage shown on the plans or as directed.

3. EQUIPMENT

Provide a self-propelled sprinkler in accordance with Article 204.3., "Equipment." Provide current calibration documentation for the tank used for distribution.

4. CONSTRUCTION

Agitate the water and emulsified asphalt to produce a uniform blend. Evenly distribute at the rate selected by the Engineer to locations shown on the plans or as directed.

- 4.1. **Base or Subgrade Treatment.** Treat the base or subgrade to the depth and width shown on the plans or as directed.

Regulate the percentage of emulsified asphalt in the mixture and distribute successive applications to achieve the specified rate. Maintain the proper moisture content of the treated material. Mix the treated material, then shape and compact as required by the specification for the course. Finish the course to the line, grade, and typical section shown on the plans. Maintain the surface with light applications of the emulsified asphalt mixture while curing the course, as directed.

- 4.2. **Erosion Control.** Apply the mixture as shown on the plans or as directed.

- 4.3. **Prime Coat.** Regulate the percentage of emulsified asphalt in the mixture and distribute successive applications to achieve the specified rate.

5. MEASUREMENT

The treatment will be measured by the gallon of emulsified asphalt used in the emulsified asphalt and water mixture.

6. PAYMENT

The work performed and materials furnished in accordance with this Item and measured as provided under "Measurement" will be paid for at the unit price bid for "Emulsified Asphalt (Base or Subgrade Treatment)," "Emulsified Asphalt (Erosion Control)," or "Emulsified Asphalt (Prime Coat)," of the type and grade specified. This price is full compensation for materials, including emulsified asphalt and water, and for equipment, labor, tools, and incidentals.

Item 315

Fog Seal



1. DESCRIPTION

Apply an emulsified asphalt and water mixture as an aggregate loss preventative or surface seal.

2. MATERIALS

Use emulsified asphalt of the type and grade shown on the plans that meet the requirements of Item 300, "Asphalts, Oils, and Emulsions." Provide water in accordance with Article 204.2., "Materials."

Use a quantity of emulsified asphalt in the mixture, expressed as a percentage of total volume, which meets the percentage shown on the plans or directed.

3. EQUIPMENT

Provide applicable equipment in accordance with Article 316.3., "Equipment." Furnish the necessary facilities and equipment for determining the temperature of the mixture, regulating the application rate, and securing uniformity at the junction of 2 distributor loads.

4. CONSTRUCTION

Apply the mixture when the air temperature is at or above 60°F, or above 50°F and rising. Measure the air temperature in the shade away from artificial heat. The Engineer will determine when weather conditions are suitable for application.

The Engineer will select the application temperature within the limits recommended in Item 300, "Asphalts, Oils, and Emulsions." Apply the material within 15°F of the selected temperature but less than the maximum allowable temperature.

Distribute material at the rate shown on the plans or as directed.

Open the treated surface to traffic when directed. Furnish and uniformly distribute clean, fine sand on the surface to blot the excess when an excessive quantity of asphalt is applied. Maintain ingress and egress as directed by applying sand to freshly sealed areas.

5. MEASUREMENT

This Item will be measured by the gallon of emulsified asphalt used in the emulsified asphalt and water mixture.

6. PAYMENT

The work performed and the materials furnished in accordance with this Item and measured as provided under "Measurement" will be paid for at the unit price bid for "Fog Seal" of the type and grade specified. This price is full compensation for materials, equipment, labor, tools, and incidentals. Blotter sand will not be paid for directly but will be subsidiary to this Item.

Item 316

Seal Coat



1. DESCRIPTION

Construct a surface treatment consisting of one or more applications of a single layer of asphalt material covered with a single layer of aggregate.

2. MATERIALS

Furnish materials of the type and grade shown on the plans in accordance with the following:

2.1. **Asphalt.** Furnish asphalt materials meeting the requirements of Item 300, "Asphalts, Oils, and Emulsions."

Furnish Type II or Type III A-R binder in accordance with Section 300.2.9., "Asphalt-Rubber Binders," as shown on the plans. Furnish a blend design for approval. Include in the design, at a minimum, the following:

- manufacturer and grade of asphalt cement;
- manufacturer and grade of crumb rubber;
- manufacturer, type, and percentage of extender oil, if used;
- test report on crumb rubber gradation in accordance with Tex-200-F, Part I;
- design percentage of crumb rubber versus asphalt content;
- blending temperature; and
- test results on the properties at reaction times of 60, 90, 240, 360, and 1,440 min. in accordance with Section 300.2.9., "Asphalt-Rubber Binders."

Furnish a new asphalt-rubber blend design if the grade or source for any of the components changes.

If a tack coat is specified when using asphalt-rubber, unless otherwise shown on the plans or approved, furnish CSS-1H, SS-1H, or a performance grade (PG) binder with a minimum high temperature grade of PG 58 for tack coat binder. Do not dilute emulsified asphalts at the terminal, in the field, or at any other location before use. If required, verify that emulsified asphalt proposed for use meets the minimum residual asphalt percentage specified in Item 300, "Asphalts, Oils, and Emulsions."

2.2. **Aggregate.** Furnish aggregate meeting Item 302, "Aggregates for Surface Treatments," of the type and grade shown on the plans. Unless otherwise shown on the plans, furnish aggregate with a minimum B Surface Aggregate Classification.

2.3. **Materials Selections.** Furnish asphalt and aggregate shown on the plans.

3. EQUIPMENT

3.1. **Distributor.** Furnish a distributor that will apply the asphalt material uniformly at the specified rate or as directed.

3.1.1. **Transverse Variable Rate.** When a transverse variable rate is shown on the plans, ensure that the nozzles outside the wheel paths will output a predetermined percentage more asphalt material by volume than the nozzles over the wheel paths. Use a dual spray bar distributor as desired to provide for a transverse variable rate.

- 3.1.2. **Agitation for Asphalt-Rubber.** If using asphalt-rubber, furnish a distributor capable of keeping the rubber in uniform suspension and adequately mixing the asphalt, rubber, and any additional additives.
- 3.1.3. **Calibration.**
- 3.1.3.1. **Transverse Distribution.** Furnish a distributor test report, less than 1 yr. old, when tested in accordance with Tex-922-K, Part III. The Department reserves the right to witness the calibration testing. Notify the Engineer 3 days before calibration testing.
- Include the following documentation on the test report:
- the serial number of the distributor,
 - a method that identifies the actual nozzle set used in the test, and
 - the fan width of the nozzle set at a 12-in. bar height.
- When a transverse variable rate is required, and a single spray bar is to be used, perform the test using the type and grade of asphalt material to be used on the project. The Engineer may verify the transverse rate and distribution at any time. If verification does not meet the requirements, correct deficiencies and furnish a new test report.
- 3.1.3.2. **Tank Volume.** Furnish a volumetric calibration and strap stick for the distributor tank in accordance with Tex-922-K, Part I.
- Provide documentation of distributor calibration performed not more than 5 yr. before the date first used on the project. The Engineer may verify calibration accuracy in accordance with Tex-922-K, Part II.
- 3.1.4. **Computerized Distributor.** When paying for asphalt material by weight, the Engineer may allow use of the computerized distributor display to verify application rates. Verify application rate accuracy at a frequency acceptable to the Engineer.
- 3.2. **Aggregate Spreader.** Use a continuous-feed, self-propelled spreader to apply aggregate uniformly at the specified rate or as directed. If racked in aggregate is specified on the plans, furnish a second aggregate spreader for the racked in aggregate to apply aggregate uniformly at the specified rate.
- 3.3. **Rollers.** Unless otherwise shown on the plans, furnish light pneumatic-tire rollers in accordance with Item 210, "Rolling."
- 3.4. **Broom.** Furnish rotary, self-propelled brooms.
- 3.5. **Asphalt Storage and Handling Equipment.** When the plans or the Engineer allows storage tanks, furnish a thermometer in each tank to indicate the asphalt temperature continuously. Keep equipment clean and free of leaks. Keep asphalt material free of contamination.
- 3.6. **Aggregate Haul Trucks.** Unless otherwise approved, use trucks of uniform capacity to deliver the aggregate. Provide documentation showing measurements and calculation in cubic yards. Clearly mark the calibrated level. Truck size may be limited when shown on the plans.
- 3.7. **Digital Distance Measuring Instrument.** Furnish a vehicle with a calibrated digital distance measuring instrument accurate to ± 6 ft. per mile.

4. CONSTRUCTION

- 4.1. **General.** Comply with the seal coat season as shown on the plans. Asphalt and aggregate rates shown on the plans are for estimating purposes only. Adjust the rates for existing conditions as directed.

- 4.2. **Temporary Aggregate Stockpiles.** The Engineer will approve the location of temporary aggregate stockpiles on the right of way before delivery. Place stockpiles in a manner that will not:
- obstruct traffic or sight distance,
 - interfere with the access from abutting property, or
 - interfere with roadway drainage.
- Locate stockpiles a minimum of 30 ft. from roadway when possible. Sign and barricade as shown on the plans.
- 4.3. **Aggregate Furnished by the Department.** When shown on the plans, the Department will furnish aggregate to the Contractor without cost. Stockpile locations are shown on the plans.
- 4.4. **Adverse Weather Conditions.** Do not place surface treatments when, in the Engineer's opinion, general weather conditions are unsuitable. Meet the requirements for air and surface temperature shown below.
- 4.4.1. **Standard Temperature Limitations.** Apply seal coat when air temperature is above 50°F and rising. Do not apply seal coat when air temperature is 60°F and falling. In all cases, do not apply seal coat when surface temperature is below 60°F.
- 4.4.2. **Polymer-Modified Asphalt Cement Temperature Limitations.** When using materials described in Section 300.2.2., "Polymer Modified Asphalt Cement," apply seal coat when air temperature is above 70°F and rising. Do not apply seal coat when air temperature is 80°F and falling. In all cases, do not apply seal coat when surface temperature is below 70°F.
- 4.4.3. **Asphalt-Rubber Temperature Limitations.** Do not place hot asphalt-rubber seal coat when, in the Engineer's opinion, general weather conditions are unsuitable. Apply seal coat when the air temperature is 80°F and above, or above 70°F and rising. In all cases, do not apply seal coat when surface temperature is below 70°F.
- 4.4.4. **Cool Weather Night Air Temperature.** The Engineer reserves the right to review the **National Oceanic and Atmospheric Administration (NOAA)** weather forecast and determine if the nightly air temperature is suitable for asphalt placement to prevent aggregate loss.
- 4.4.5. **Cold Weather Application.** When asphalt application is allowed outside of the above temperature restrictions, the Engineer will approve the binder grade and the air and surface temperatures for asphalt material application. Apply seal coat at air and surface temperatures as directed.
- 4.5. **Mixing Hot A-R Binder.** If using asphalt-rubber, mix in accordance with the approved blend design required in Section 316.2.1., "Asphalt."
- At the end of each shift, provide the Engineer with production documentation, which includes the following:
- amount and temperature of asphalt cement before addition of rubber,
 - amount of rubber and any extender added,
 - viscosity of each hot A-R batch just before roadway placement, and
 - time of the rubber additions and viscosity tests.
- 4.6. **Surface Preparation.** Remove existing raised pavement markers. Repair any damage incurred by removal as directed. Remove dirt, dust, or other harmful material before sealing. When shown on the plans, remove vegetation and blade pavement edges. When directed, apply a tack coat before applying the hot asphalt-rubber treatment on an existing wearing surface in accordance with Section 340.2.5., "Tack Coat."
- 4.7. **Rock Land and Shot.**
- 4.7.1. **Definitions.**
- A "rock land" is the area covered at the aggregate rate directed with 1 truckload of aggregate.

- A “shot” is the area covered by 1 distributor load of asphalt material.

4.7.2. **Setting Lengths.** Calculate the lengths of both rock land and shot. Adjust shot length to be an even multiple of the rock land. Verify that the distributor has enough asphalt material to complete the entire shot length. Mark shot length before applying asphalt. When directed, mark length of each rock land to verify the aggregate rate.

4.8. **Asphalt Placement.**

4.8.1. **General.** The maximum shot width is the width of the current transverse distribution test required under Section 316.3.1.3.1., “Transverse Distribution,” or the width of the aggregate spreader box, whichever is less. Adjust the shot width so operations do not encroach on traffic or interfere with the traffic control plan, as directed. Use paper or other approved material at the beginning and end of each shot to construct a straight transverse joint and to prevent overlapping of the asphalt. Unless otherwise approved, match longitudinal joints with the lane lines. The Engineer may require a string line if necessary to keep joints straight with no overlapping. Use sufficient pressure to flare the nozzles fully.

Select an application temperature, as approved, in accordance with Item 300, “Asphalts, Oils, and Emulsions.” Uniformly apply the asphalt material at the rate directed, within 15°F of the approved temperature, and not above the maximum allowable temperature.

4.8.2. **Limitations.** Do not apply asphalt to the roadway until:

- traffic control methods and devices are in place as shown on the plans or as directed,
- the loaded aggregate spreader is in position and ready to begin,
- haul trucks are loaded with enough aggregate to cover the shot area and are in place behind the spreader box, and
- rollers are in place behind the haul trucks.

4.8.3. **Nonuniform Application.** Stop application if it is not uniform due to streaking, ridging, puddling, or flowing off the roadway surface. Verify equipment condition, operating procedures, application temperature, and material properties. Determine and correct the cause of nonuniform application. If the cause is high or low emulsion viscosity, replace emulsion with material that corrects the problem.

4.8.4. **Test Strips.** The Engineer may stop asphalt application and require construction of test strips at the Contractor’s expense if any of the following occurs:

- nonuniformity of application continues after corrective action;
- on 3 consecutive shots, application rate differs by more than 0.03 gal. per square yard from the rate directed; or
- any shot differs by more than 0.05 gal. per square yard from the rate directed.

The Engineer will approve the test strip location. The Engineer may require additional test strips until surface treatment application meets specification requirements.

4.9. **Aggregate Placement.** As soon as possible, apply aggregate uniformly at the rate directed without causing the rock to roll over.

4.9.1. **Nonuniform Application.** Stop application if it is not uniform in the transverse direction. Verify equipment condition, operating procedures, and transverse application rate. The transverse application rate should be within 1 lb. Determine and correct the cause of nonuniform application.

4.10. **Rolling.** Start rolling operation on each shot as soon as aggregate is applied. Use sufficient rollers to cover the entire mat width in 1 pass, i.e., 1 direction. Roll in a staggered pattern. Unless otherwise shown on the plans, make a minimum of:

- 5 passes; or

- 3 passes when the asphalt material is an emulsion.

If rollers are unable to keep up with the spreader box, stop application until rollers have caught up, or furnish additional rollers. Keep roller tires asphalt-free.

- 4.11. **Patching.** Before rolling, repair spots where coverage is incomplete. Repair can be made by hand spotting or other approved method. When necessary, apply additional asphalt material to embed aggregate.
- 4.12. **Racked-in Aggregate.** If specified on the plans, apply racked-in aggregate after patching, uniformly at the rate directed. The racked-in aggregate must be applied before opening the roadway or intersection to traffic.
- 4.13. **Brooming.** After rolling, sweep as soon as aggregate has sufficiently bonded to remove excess. In areas of racked-in aggregate, sweep as directed.
- 4.14. **Final Acceptance.** Maintain seal coat until the Engineer accepts the work. Repair any surface failures. Before final project acceptance, remove all temporary stockpiles and restore the area to the original contour and grade.

5. MEASUREMENT

- 5.1. **Asphalt Material.** Unless otherwise shown on the plans, asphalt material will be measured by one of the following methods:
- 5.1.1. **Volume.** Asphalt material, including all components, will be measured at the applied temperature by strapping the tank before and after road application. The distributor calibrated strap stick will be used for measuring the asphalt level in the distributor asphalt tank. The certified tank chart will be used to determine the beginning gallons and the final gallons in the distributor tank. The quantity to be measured for payment will be the difference between the beginning gallons and the final gallons.
- 5.1.2. **Weight.** Asphalt material will be measured in tons using certified scales meeting the requirements of Item 520, "Weighing and Measuring Equipment," unless otherwise approved. The transporting truck must have a seal attached to the draining device and other openings. Random checking on public scales at the Contractor's expense may be required to verify weight accuracy.
- Upon work completion or temporary suspension, any remaining asphalt material will be weighed by a certified public weigher, or measured by volume in a calibrated distributor or tank and the quantity converted to tons at the measured temperature. The quantity to be measured will be the number of tons received minus the number of tons remaining after all directed work is complete and minus the amount used for other items.
- 5.1.3. **Quantity Adjustments.** When shown on the plans, the measured quantity will be adjusted to compensate for variation in required application or residual rates for different types of asphalt.
- 5.2. **Aggregate.** Aggregate will be measured by the cubic yard in the trucks as applied on the road. Strike off the loaded aggregate for accurate measurement when directed.
- 5.3. **Loading, Hauling, and Distributing Aggregate.** When the Department furnishes the aggregate, the loading, hauling, and distributing will be measured by the cubic yard in the trucks as applied on the road.

6. PAYMENT

The work performed and materials furnished in accordance with this Item and measured as provided under "Measurement" will be paid for at the unit prices bid for "Asphalt," "Aggregate," and "Loading, Hauling, and Distributing Aggregate" of the types-grades specified on the plans. These prices are full compensation for surface preparation; furnishing, preparing, hauling, and placing materials; removing existing pavement markers and excess aggregate; rolling; cleaning up stockpiles; and equipment, labor, tools, and incidentals.

Item 320

Equipment for Asphalt Concrete Pavement



1. DESCRIPTION

Provide equipment to produce, haul, place, compact, and core asphalt concrete pavement.

2. EQUIPMENT

Ensure weighing and measuring equipment complies with Item 520, "Weighing and Measuring Equipment." Synchronize equipment to produce a mixture meeting the required proportions.

2.1. Production Equipment. Provide:

- drum-mix type, weigh-batch, or modified weigh-batch mixing plants that ensure a uniform, continuous production;
- automatic proportioning and measuring devices with interlock cut-off circuits that stop operations if the control system malfunctions;
- visible readouts indicating the weight or volume of asphalt and aggregate proportions;
- safe and accurate means to take required samples by inspection forces;
- permanent means to check the output of metering devices and to perform calibration and weight checks; and
- additive-feed systems to ensure a uniform, continuous material flow in the desired proportion.

2.1.1. Drum-Mix Plants. Provide a mixing plant that complies with the requirements below.

2.1.1.1. Aggregate Feed System. Provide:

- a minimum of one cold aggregate bin for each stockpile of individual materials used to produce the mix;
- bins designed to prevent overflow of material;
- scalping screens or other approved methods to remove any oversized material, roots, or other objectionable materials;
- a feed system to ensure a uniform, continuous material flow in the desired proportion to the dryer;
- an integrated means for moisture compensation;
- belt scales, weigh box, or other approved devices to measure the weight of the combined aggregate; and
- cold aggregate bin flow indicators that automatically signal interrupted material flow.

2.1.1.2. Reclaimed Asphalt Pavement (RAP) and Recycled Asphalt Shingles (RAS) Feed Systems. Provide a minimum of one bin for each stockpile of RAP and RAS to weigh and feed the recycled material into the hot-mix plant.

2.1.1.3. Mineral Filler Feed System. Provide a closed system for mineral filler that maintains a constant supply with minimal loss of material through the exhaust system. Interlock the measuring device into the automatic plant controls to automatically adjust the supply of mineral filler to plant production and provide a consistent percentage to the mixture.

2.1.1.4. Heating, Drying, and Mixing Systems. Provide:

- a dryer or mixing system to agitate the aggregate during heating;
- a heating system that controls the temperature during production to prevent aggregate and asphalt binder damage;

- a heating system that completely burns fuel and leaves no residue; and
- a recording thermometer that continuously measures and records the mixture discharge temperature.

- 2.1.1.5. **Dust Collection System.** Provide a dust collection system to collect fines generated by the drying and mixing process and reintroduce them into the mixing drum.
- 2.1.1.6. **Asphalt Binder Equipment.** Supply equipment to heat binder to the required temperature. Equip the heating apparatus with a continuously recording thermometer located at the highest temperature point. Produce a 24-hr. chart of the recorded temperature. Place a device with automatic temperature compensation that accurately meters the binder in the line leading to the mixer.
- Furnish a sampling port on the line between the storage tank and mixer. Supply an additional sampling port between any additive blending device and mixer.
- Supply an in-line viscosity-measuring device located between the blending unit and the mixing drum when A-R binder is specified. Provide a means to calibrate the meter on site when an asphalt mass flow meter is used.
- 2.1.1.7. **Mixture Storage and Discharge.** Provide a surge-storage system to minimize interruptions during operations unless otherwise approved. Furnish a gob hopper or other device to minimize segregation in the bin. Provide an automated system that weighs the mixture upon discharge and produces a ticket showing:
- date,
 - project identification number,
 - plant identification,
 - mix identification,
 - vehicle identification,
 - total weight of the load,
 - tare weight of the vehicle,
 - weight of mixture in each load, and
 - load number or sequential ticket number for the day.
- 2.1.1.8. **Truck Scales.** Provide standard platform scales at an approved location.
- 2.1.2. **Weigh-Batch Plants.** Provide a mixing plant that complies with Section 320.2.1.1., "Drum-Mix Plants," except as required below.
- 2.1.2.1. **Screening and Proportioning.** Provide enough hot bins to separate the aggregate and to control proportioning of the mixture type specified. Supply bins that discard excessive and oversized material through overflow chutes. Provide safe access for inspectors to obtain samples from the hot bins.
- 2.1.2.2. **Aggregate Weigh Box and Batching Scales.** Provide a weigh box and batching scales to hold and weigh a complete batch of aggregate. Provide an automatic proportioning system with low bin indicators that automatically stop when material level in any bin is not enough to complete the batch.
- 2.1.2.3. **Asphalt Binder Measuring System.** Provide bucket and scales with enough capacity to hold and weigh binder for one batch.
- 2.1.2.4. **Mixer.** Equip mixers with an adjustable automatic timer that controls the dry and wet mixing period and locks the discharge doors for the required mixing period. Furnish a pug mill with a mixing chamber large enough to prevent spillage.
- 2.1.3. **Modified Weigh-Batch Plants.** Provide a mixing plant that complies with Section 320.2.1.2., "Weigh-Batch Plants," except as specifically described below.
- 2.1.3.1. **Aggregate Feeds.** Aggregate control is required at the cold feeds. Hot bin screens are not required.

- 2.1.3.2. **Surge Bins.** Provide one or more bins large enough to produce 1 complete batch of mixture.
- 2.2. **Hauling Equipment.** Provide trucks with enclosed sides to prevent asphalt mixture loss. Cover each load of mixture with waterproof tarpaulins when shown on the plans or required by the Engineer. Clean all truck beds before use to ensure the mixture is not contaminated. Coat the inside truck beds, when necessary, with an approved release agent from the Department's MPL.
- 2.3. **Placement and Compaction Equipment.** Provide equipment that does not damage underlying pavement. Comply with laws and regulations concerning overweight vehicles. Use other equipment that will consistently produce satisfactory results, when approved.
- 2.3.1. **Asphalt Paver.** Furnish a paver that will produce a finished surface that meets longitudinal and transverse profile, typical section, and placement requirements. Ensure the paver does not support the weight of any portion of hauling equipment other than the connection. Provide loading equipment that does not transmit vibrations or other motions to the paver that adversely affect the finished pavement quality. Equip the paver with an automatic, dual, longitudinal-grade control system and an automatic, transverse-grade control system.
- 2.3.1.1. **Tractor Unit.** Supply a tractor unit that can push or propel vehicles, dumping directly into the finishing machine to obtain the desired lines and grades to eliminate any hand finishing. Equip the unit with a hitch able to maintain contact between the hauling equipment's rear wheels and the finishing machine's pusher rollers while mixture is unloaded.
- 2.3.1.2. **Screed.** Provide a heated compacting screed that will produce a finished surface that meets longitudinal and transverse profile, typical section, and placement requirements. Screed extensions must provide the same compacting action and heating as the main unit unless otherwise approved.
- 2.3.1.3. **Grade Reference.** Provide a grade reference with enough support that the maximum deflection does not exceed 1/16 in. between supports. Ensure that the longitudinal controls can operate from any longitudinal grade reference including a string line, ski, mobile reference, or joint matching shoes.
- 2.3.2. **Material Transfer Devices.** Provide the specified type of device when shown on the plans. Ensure the devices provide a continuous, uniform mixture flow to the asphalt paver. Provide windrow pick-up equipment, when used, constructed to pick up substantially all roadway mixture placed in the windrow.
- 2.3.3. **Remixing Equipment.** Provide equipment, when required, that includes a pug mill, variable pitch augers, or variable diameter augers operating under a storage unit with a minimum capacity of 8 tons.
- 2.3.4. **Motor Grader.** Provide a self-propelled grader, when allowed, with a blade length of at least 12 ft. and a wheelbase of at least 16 ft.
- 2.3.5. **Thermal Imaging System or Hand-Held Thermal Camera.** Provide a thermal imaging system or hand-held thermal camera meeting the requirements of Tex-244-F.
- 2.3.6. **Rollers.** Provide rollers meeting the requirements of Item 210, "Rolling," for each type of roller required for compaction.
- 2.3.7. **Straightedges and Templates.** Furnish 10-ft. straightedges and other templates as required or approved.
- 2.4. **Field Laboratory.** Provide and maintain a Type D Structure (Asphalt Mix Control Laboratory) unless otherwise shown on the plans in accordance with Item 504, "Field Office and Laboratory," and details shown on the plans.
- 2.5. **Coring Equipment.** Provide equipment suitable to obtain a pavement specimen meeting the dimensions for testing when coring is required.

3. MEASUREMENT AND PAYMENT

The work performed, materials furnished, equipment, labor, tools, and incidentals will not be measured or paid for directly but will be subsidiary to pertinent Items.

Item 330

Limestone Rock Asphalt Pavement



1. DESCRIPTION

Construct a base course, a surface course, a level-up course, or any combination of these courses of the types and grades shown on the plans using a cold-mixed material consisting of native limestone rock asphalt (LRA) aggregate, fluxing material, water, and when specified, additives and virgin aggregates.

2. MATERIALS

2.1. **LRA Mixture.** Furnish LRA according to DMS-9210, "Limestone Rock Asphalt (LRA)," of the type, grade, and Surface Aggregate Classification (SAC) shown on the plans.

2.2. **Tack Coat.** Furnish CSS-1H, SS-1H, or a performance-graded (PG) binder with a minimum high-temperature grade of PG 58 for tack coat binder in accordance with Item 300, "Asphalts, Oils, and Emulsions," unless otherwise shown on the plans or approved. Do not dilute emulsified asphalts at the terminal, in the field, or at any other location before use. Verify that emulsified asphalt proposed for use meets the minimum residual asphalt percentage specified in Item 300, "Asphalts, Oils, and Emulsions," if required.

The Engineer will obtain at least one sample of the tack coat per project and test the sample for specification compliance. The Engineer will obtain the sample from the asphalt distributor immediately before use.

3. EQUIPMENT

Provide required or necessary equipment in accordance with Item 320, "Equipment for Asphalt Concrete Pavement."

4. CONSTRUCTION

Provide quality control (QC) testing as needed to meet the requirements of this Item. The Department will perform quality assurance (QA) testing.

4.1. **Quality Control Plan (QCP).** Develop a written QCP and submit for approval before beginning production. Follow QCP in detail. Obtain approval for changes to the QCP made during the project. The Engineer may suspend operations if the Contractor fails to comply with the QCP.

Include the following items in the QCP:

4.1.1. **Project Personnel.** For project personnel, include:

- a list of individuals responsible for QC with authority to take corrective action, and
- current contact information for each individual listed.

4.1.2. **Loading and Transporting.** For loading and transporting, include:

- type and application method for release agents, and
- truck and rail car loading procedures to avoid segregation.

4.1.3. **Placement and Compaction.** For placement and compaction, include:

- proposed arrangements for any required pre-paving meetings, including dates and locations;

- type and application method for release agents in the paver and on rollers, shovels, lutes, and other utensils;
- procedures for the transfer of mixture into the paver while avoiding segregation and preventing material spillage;
- process to balance production, delivery, paving, and compaction to achieve continuous placement operations;
- paver operations (e.g., operation of wings, height of mixture in auger chamber) to avoid physical and thermal segregation and other surface irregularities; and
- procedures to construct quality longitudinal and transverse joints.

4.2. **Stockpiling of LRA.** Provide a smooth and well-drained area, cleared of trash, weeds, and grass if storing LRA at the project site. Stockpile, handle, and load LRA in a manner that will minimize aggregate degradation and segregation. Avoid contamination and mixing of stockpiles. The Engineer may reject stockpiled materials that come in contact with the earth or other objectionable material.

4.3. **Hauling Operations.** Transport the LRA mixture to the project or delivery point in trucks or rail cars as needed. Clean all truck beds or rail cars before use to ensure mixture is not contaminated. Use a release agent on the Department's MPL to coat truck beds and inside rail cars when necessary. Waterproof tarpaulins are not required to cover loads.

4.4. **Placement Operations.** Prepare the surface by removing raised pavement markers and objectionable material such as moisture, dirt, sand, leaves, and other loose impediments from the surface before placing mixture. Remove vegetation from pavement edges. Place the mixture to meet the typical section requirements and produce a smooth, finished surface with a uniform appearance and texture. Offset longitudinal joints of successive courses of mixture by at least 6 in. Place mixture so longitudinal joints on the surface course coincide with lane lines, or as directed. Ensure that all finished surfaces will drain properly.

When desired, dump the asphalt mixture in a windrow and then place it in the finishing machine with windrow pickup equipment unless otherwise shown on the plans. Prevent the windrow pickup equipment from contaminating the mixture.

Defer compaction after placing the paving mixture as directed to allow for volatilization. Allow the previous pavement course to dry and cure before placing the next course when placing more than one course. The course will be considered cured if the hydrocarbon volatile content of the mixture is 0.4% or less by weight of the mixture when tested according to Tex-213-F, unless otherwise directed.

Use a motor grader to spread the mixture when shown on the plans or as approved. Thoroughly aerate the mixture and spread into place with a power motor grader in a uniform layer. Placement in narrow strips or small irregular areas may require hand spreading.

4.4.1. **Weather Conditions.** Place the mixture when the roadway surface temperature is 60°F or higher unless otherwise approved. Place the mixture only when the weather conditions and moisture conditions of the roadway surface are suitable in the opinion of the Engineer.

4.4.2. **Tack Coat.** Clean the surface before placing the tack coat. Apply tack coat uniformly at the approved rate, unless otherwise directed. The Engineer will set the rate between 0.04 and 0.10 gallons of residual asphalt per square yard of surface area. Apply a thin, uniform tack coat to all contact surfaces of curbs, structures, and joints. Prevent splattering of the tack coat when placed adjacent to curb, gutter, and structures. Roll the tack coat with a pneumatic-tire roller to remove streaks and other irregular patterns when directed.

4.5. **Compaction.** Furnish the type, size, and number of rollers required for compaction, as approved. Furnish at least one medium pneumatic-tire roller (minimum 12-ton weight). Use Tex-207-F, Part IV, to establish rolling patterns that achieve maximum compaction. Follow the selected rolling pattern unless changes that affect compaction occur in the mixture or placement conditions. Establish a new rolling pattern when such changes occur. Compact the pavement to the cross-section of the finished paving mixture meeting the requirements

of the plans and specifications. Operate vibratory rollers in static mode when not compacting or changing directions, or when the plan depth of the pavement mat is less than 1-1/2 in. unless otherwise directed.

Start by first rolling the joint with the adjacent pavement and then continue by rolling longitudinally at the sides when rolling with the 3-wheel, tandem, or vibratory rollers. Proceed toward the center of the pavement, overlapping on successive trips by at least 1 ft., unless otherwise directed. Make alternate trips of the roller slightly different in length. Begin rolling at the low side and progress toward the high side on superelevated curves unless otherwise directed.

Avoid displacement of the mixture. Correct any displacement that may occur to the satisfaction of the Engineer. Ensure pavement is fully compacted before allowing rollers to stand on the pavement. Use only water or an approved release agent on rollers, tamps, and other compaction equipment unless otherwise directed. Keep diesel, gasoline, oil, grease, and other foreign matter off the mixture.

Use tamps to thoroughly compact the edges of the pavement along curbs, headers, and similar structures and in locations that will not allow thorough compaction with the rollers. The Engineer may require rolling with a trench roller on widened areas, in trenches, and in other limited areas.

- 4.6. **Irregularities.** Immediately take corrective actions if surface irregularities, including segregation, rutting, raveling, flushing, fat spots, mat slippage, color, texture, roller marks, tears, gouges, streaks, or uncoated aggregate particles are detected. The Engineer may allow placement to continue for no more than one day of production while the Contractor takes appropriate action. Suspend paving if the problem still exists after that day until it is corrected to the satisfaction of the Engineer.

Remove and replace any mixture that does not bond to the existing pavement or has other surface irregularities identified above at the expense of the Contractor and to the satisfaction of the Engineer.

- 4.7. **Ride Quality.** Use Surface Test Type A to evaluate ride quality in accordance with Item 585, "Ride Quality for Pavement Surfaces," unless otherwise shown on the plans.

5. MEASUREMENT

LRA pavement will be measured by the ton of composite LRA pavement of the type actually used in the completed and accepted work in accordance with the plans and specifications for the project. Measure on scales in accordance with Item 520, "Weighing and Measuring Equipment." Keep records on tare weight, gross weight, and net weight of the LRA paving mixture for each load of the same type of mixture. The Construction Division will measure and report the moisture content in accordance with Tex-212-F, Part II of the LRA paving mixture used to determine payment at the plant. All water and light hydrocarbon volatiles in the mixture measured in accordance with Tex-212-F, Part II, in excess of 6.0% by weight at the time of weighing, will be deducted from the net weight to determine the quantity for payment.

6. PAYMENT

The work performed and materials furnished in accordance with this Item and measured as provided under Article 330.5, "Measurement," will be paid for at the unit price bid for "Limestone Rock Asphalt Pavement" of the type, grade, and SAC specified.

These prices are full compensation for surface preparation, materials including tack coat, placement, equipment, labor, tools, and incidentals.

Payment adjustment for ride quality, when required, will be determined in accordance with Item 585, "Ride Quality for Pavement Surfaces."

Item 334

Hot-Mix Cold-Laid Asphalt Concrete Pavement



1. DESCRIPTION

Construct a cold-laid pavement layer composed of a compacted mixture of aggregate and asphalt material mixed hot in a mixing plant.

This Item governs mixtures designed for cold placement, defined as placement temperatures below 175°F. If the mixture placement temperature is greater than 175°F, then design, produce, place, and compact the mixture in accordance with the applicable hot-mix asphalt specification.

2. MATERIALS

Furnish uncontaminated materials of uniform quality that meet the requirements of the plans and specifications.

Notify the Engineer of all material sources and before changing any material source or formulation. The Engineer will verify that the specification requirements are met when the Contractor makes a source or formulation change, and may require a new laboratory mixture design, trial batch, or both. The Engineer may sample and test project materials at any time during the project to verify specification compliance in accordance with Item 6, "Control of Materials."

- 2.1. **Aggregate.** Furnish aggregates from sources that conform to the requirements shown in Table 1 and as specified in this Section. Aggregate requirements in this Section, including those shown in Table 1, may be modified or eliminated when shown on the plans. Additional aggregate requirements may be specified when shown on the plans. Provide aggregate stockpiles that meet the definitions in this Section for coarse, intermediate, or fine aggregate. Supply aggregates that meet the definitions in Tex-100-E for crushed gravel or crushed stone. The Engineer will designate the plant or the quarry as the sampling location. Provide samples from materials produced for the project. The Engineer will establish the Surface Aggregate Classification (SAC) and perform Los Angeles abrasion, magnesium sulfate soundness, and Micro-Deval tests. Perform all other aggregate quality tests listed in Table 1. Document all test results on the mixture design report. The Engineer may perform tests on independent or split samples to verify Contractor test results. Stockpile aggregates for each source and type separately. Determine aggregate gradations for mixture design and production testing based on the washed sieve analysis given in Tex-200-F, Part II.

- 2.1.1. **Coarse Aggregate.** Coarse aggregate stockpiles must have no more than 20% material passing the No. 8 sieve. Aggregates from sources listed in the Department's *Bituminous Rated Source Quality Catalog* (BRSQC) are preapproved for use. Use only the rated values for hot-mix listed in the BRSQC. Rated values for surface treatment (ST) do not apply to coarse aggregate sources used in hot-mix asphalt.

For sources not listed on the Department's BRSQC:

- build an individual stockpile for each material;
- request the Department test the stockpile for specification compliance; and
- once approved, do not add material to the stockpile unless otherwise approved.

Provide aggregate from non-listed sources only when tested by the Engineer and approved before use. Allow 30 calendar days for the Engineer to sample, test, and report results for non-listed sources.

Provide coarse aggregate with at least the minimum SAC shown on the plans. SAC requirements only apply to aggregates used on the surface of travel lanes. SAC requirements apply to aggregates used on surfaces

other than travel lanes when shown on the plans. The SAC for sources on the Department's *Aggregate Quality Monitoring Program (AQMP)* (Tex-499-A) is listed in the BRSQC.

2.1.1.1. **Blending Class A and Class B Aggregates.** Class B aggregate meeting all other requirements in Table 1 may be blended with a Class A aggregate to meet requirements for Class A materials. Ensure that at least 50% by weight, or volume if required, of the material retained on the No. 4 sieve comes from the Class A aggregate source when blending Class A and B aggregates to meet a Class A requirement. Blend by volume if the bulk specific gravities of the Class A and B aggregates differ by more than 0.300.

2.1.2. **Fine Aggregate.** Fine aggregates consist of manufactured sands, screenings, and field sands. Fine aggregate stockpiles must meet the gradation requirements in Table 2. Supply fine aggregates that are free from organic impurities. The Engineer may test the fine aggregate in accordance with Tex-408-A to verify the material is free from organic impurities. No more than 15% of the total aggregate may be field sand or other uncrushed fine aggregate. Use fine aggregate, with the exception of field sand, from coarse aggregate sources that meet the requirements shown in Table 1 unless otherwise approved.

Test the stockpile if 10% or more of the stockpile is retained on the No. 4 sieve, and verify that it meets the requirements in Table 1 for crushed face count (Tex-460-A) and flat and elongated particles (Tex-280-F).

Table 1
Aggregate Quality Requirements

Property	Test Method	Requirement
Coarse Aggregate		
SAC	Tex-499-A (AQMP)	As shown on the plans
Deleterious material, %, Max	Tex-217-F, Part I	1.5
Decantation, %, Max	Tex-217-F, Part II	1.5
Micro-Deval abrasion, %	Tex-461-A	Note ¹
Los Angeles abrasion, %, Max	Tex-410-A	40
Magnesium sulfate soundness, 5 cycles, %, Max	Tex-411-A	30 ²
Crushed face count, ³ %, Min	Tex-460-A, Part I	85
Flat and elongated particles @ 5:1, %, Max	Tex-280-F	10
Fine Aggregate		
Linear shrinkage, %, Max	Tex-107-E	3
Combined Aggregates⁴		
Sand equivalent, %, Min	Tex-203-F	45

1. Not used for acceptance purposes. Used by the Engineer as an indicator of the need for further investigation.
2. Unless otherwise shown on the plans.
3. Only applies to crushed gravel.
4. Aggregates, without mineral filler or additives, combined as used in the job-mix formula (JMF).

Table 2
Gradation Requirements for Fine Aggregate

Sieve Size	% Passing by Weight or Volume
3/8"	100
#8	70–100
#200	0–15

2.2. **Mineral Filler.** Mineral filler consists of finely divided mineral matter such as agricultural lime, crusher fines, hydrated lime, or fly ash. Mineral filler is allowed unless otherwise shown on the plans. Use no more than 2% hydrated lime or fly ash unless otherwise shown on the plans. The plans may require or disallow specific mineral fillers. Provide mineral filler, when used, that:

- is sufficiently dry, free-flowing, and free from clumps and foreign matter as determined by the Engineer;
- does not exceed 3% linear shrinkage when tested in accordance with Tex-107-E; and
- meets the gradation requirements in Table 3.

Table 3
Gradation Requirements for Mineral Filler

Sieve Size	% Passing by Weight or Volume
#8	100
#200	55–100

- 2.3. **Baghouse Fines.** Fines collected by the baghouse or other dust-collecting equipment may be reintroduced into the mixing drum.
- 2.4. **Binder Material.** Furnish asphalt binder, primer, additives, and water, unless otherwise shown on the plans.
- 2.4.1. **Asphalt Binder.** Provide the asphalt shown on the plans, meeting the requirements of Item 300, "Asphalts, Oils, and Emulsions."
- 2.4.2. **Primer.** Provide an approved asphalt primer consisting of a blend of asphalt cement and hydrocarbon volatiles.
- 2.4.3. **Water.** Provide water that meets the requirements of Item 204, "Sprinkling."
- 2.4.4. **Additives.** Use the type and rate of additive specified when shown on the plans. Additives that facilitate mixing or improve the quality of the mixture may be allowed when approved. Provide the Engineer with documentation such as the bill of lading showing the quantity of additives used in the project unless otherwise directed.

When lime or liquid antistripping agents is used, add in accordance with Item 301, "Asphalt Antistripping Agents." Do not add lime directly into the mixing drum of any plant where lime is removed through the exhaust stream unless the plant has a baghouse or dust collection system that reintroduces the lime back into the drum.

- 2.5. **Tack Coat.** Furnish CSS-1H, SS-1H, or a performance-graded (PG) binder with a minimum high-temperature grade of PG 58 for tack coat in accordance with Item 300, "Asphalts, Oils, and Emulsions." Specialized or preferred tack coat materials may be allowed or required when shown on the plans. Do not dilute emulsified asphalts at the terminal, in the field, or at any other location before use. The Department may sample the tack coat to verify specification compliance.

3. EQUIPMENT

Provide required or necessary equipment in accordance with Item 320, "Equipment for Asphalt Concrete Pavement."

4. CONSTRUCTION

Design, produce, store, transport, place, and compact the specified paving mixture in accordance with the requirements of this Item. Provide the mix design unless otherwise shown on the plans. The Department will perform quality assurance (QA) testing. Provide quality control (QC) testing as needed to meet the requirements of this Item.

- 4.1. **Mixture Design.**
- 4.1.1. **Design Requirements.** Use the typical weight design example given in Tex-204-F, Part I to design a paving mixture that consists of a uniform mixture of aggregate, asphalt material, primer, additives, and water, if allowed, which meets the requirements shown in Tables 4 and 5, unless otherwise shown on the plans. Ensure that the mixture leaves the plant in a workable condition. Provide materials that remain workable in a stockpile for at least 6 mo.

Submit a new mixture design at any time during the project. The Engineer must approve all mixture designs before the Contractor can begin production.

4.1.2.

Job-Mix Formula Approval. The job-mix formula (JMF) is the combined aggregate gradation and target asphalt percentage used to establish target values for mixture production. JMF1 is the original laboratory mixture design used to produce the trial batch. The Engineer will verify JMF1 based on plant-produced mixture from the trial batch unless otherwise approved. The Engineer may accept an existing mixture design previously used on a Department project and may waive the trial batch to verify JMF1. Provide the Engineer with split samples of the mixtures and blank samples used to determine the ignition oven correction factors. The Engineer will determine the aggregate and asphalt correction factors from the ignition oven using Tex-236-F.

Table 4
Master Gradation Limits (% Passing by Weight or Volume) and VMA Requirements

Sieve Size	A Coarse Base	B Fine Base	C Coarse Surface	D Fine Surface	F Fine Mixture
2"	100.0 ¹	–	–	–	–
1-1/2"	98.0–100.0	100.0 ¹	–	–	–
1"	78.0–94.0	98.0–100.0	100.0 ¹	–	–
3/4"	64.0–85.0	84.0–98.0	95.0–100.0	100.0 ¹	–
1/2"	50.0–70.0	–	–	98.0–100.0	100.0 ¹
3/8"	–	60.0–80.0	70.0–85.0	85.0–100.0	98.0–100.0
#4	30.0–50.0	40.0–60.0	43.0–63.0	50.0–70.0	70.0–90.0
#8	22.0–36.0	29.0–43.0	32.0–44.0	35.0–46.0	38.0–48.0
#30	8.0–23.0	13.0–28.0	14.0–28.0	15.0–29.0	12.0–27.0
#50	3.0–19.0	6.0–20.0	7.0–21.0	7.0–20.0	6.0–19.0
#200	2.0–7.0	2.0–7.0	2.0–7.0	2.0–7.0	2.0–7.0
Design VMA,² % Minimum					
–	12.0	13.0	14.0	15.0	16.0
Production (Plant-Produced) VMA,² % Minimum					
–	11.5	12.5	13.5	14.5	15.5

1. Defined as maximum sieve size. No tolerance allowed.
2. Voids in mineral aggregates.

Table 5
Laboratory Mixture Design Properties

Property	Test Method	Requirement
Target laboratory-molded density, % ¹	Tex-207-F	92.5 ± 1.5
Hveem stability, Min	Tex-208-F	35
Hydrocarbon-volatile content, %, Max	Tex-213-F	0.6
Moisture content, %, Max ²	Tex-212-F	1.0
Boil test, %, Max ³	Tex-530-C	10

1. Unless otherwise shown on the plans.
2. Unless otherwise approved.
3. Limit may be increased or eliminated when approved.

4.2.

Production Operations. Perform a new trial batch when the plant or plant location is changed. Take corrective action and obtain approval to proceed after any production suspension for noncompliance to the specification.

4.2.1.

Stockpiling of Aggregates. Provide a smooth and well-drained area, cleared of trash, weeds, and grass. Build stockpiles in a manner that will minimize aggregate degradation and segregation. Avoid contamination and mixing of stockpiles. Provide aggregate stockpiles for a minimum of 2 days' production before beginning plant operations. Maintain at least a 2-day aggregate supply through the course of the project unless otherwise directed. Stockpile aggregate for each source and type separately. The Engineer may reject stockpiled materials that come in contact with the earth or other objectionable material.

4.2.2.

Storage and Heating of Asphalt Materials. Provide enough asphalt material storage capacity to meet the requirements of the plant. Do not heat the asphalt binder above the temperatures specified in Item 300, "Asphalts, Oils, and Emulsions," or outside the manufacturer's recommended values. Keep all equipment

used in the storage and handling of asphalt material clean at all times and operate the equipment in a manner that will prevent contamination with foreign matter.

- 4.2.3. **Storage of the Asphalt Mixture.** Store the asphalt mixture in a surge-storage system or in a stockpile. Provide a smooth and well-drained area, cleared of trash, weeds, and grass if the asphalt mixture is stored in a stockpile. Build stockpiles in a manner that will minimize aggregate degradation and segregation. Avoid contamination and mixing of stockpiles.
- 4.2.4. **Mixing and Discharge of Materials.** Produce the mixture at a discharge temperature between 145°F and 275°F, as directed. Do not allow the temperature to vary from the selected temperature by more than 25°F. The Department will not pay for or allow placement of any mixture produced above 300°F.
- 4.2.5. **Moisture Content.** Furnish the mixture at a moisture content of no more than 1% by weight when discharged from the mixer, unless otherwise shown on the plans or approved. Cease operations at moisture contents above 1% until corrective actions reduce moisture content.
- 4.3. **Hauling Operations.** Clean all truck beds before use to ensure mixture is not contaminated. Use a release agent on the Department's MPL to coat truck beds when a release agent is necessary.
- 4.4. **Placement Operations.** Prepare the surface by removing raised pavement markers and objectionable material such as moisture, dirt, sand, leaves, and other loose impediments from the surface before placing mixture. Remove vegetation from pavement edges. Place mixture on the road below 175°F. Place the mixture to produce a smooth, finished surface with a uniform appearance and texture that meet typical section requirements. Offset longitudinal joints of successive courses of mixture by at least 6 in. Place mixture so that longitudinal joints on the surface course coincide with lane lines, or as directed. Ensure that all finished surfaces will drain properly.

When desired, dump the asphalt mixture in a windrow and then place in the finishing machine with windrow pickup equipment unless otherwise shown on the plans. Prevent the windrow pickup equipment from contaminating the mixture.

Defer compaction after placing the paving mixture, as directed, to allow for volatilization. Allow the previous course to dry and cure before placing the next course when placing more than one pavement course. Consider the course cured if the hydrocarbon volatile content of the mixture is 0.4% or less by weight of the mixture when tested according to Tex-213-F unless otherwise directed.

Use a motor grader to spread the mixture when shown on the plans or approved. Thoroughly aerate the mixture and spread into place with a power motor grader in a uniform layer. Placement in narrow strips or small irregular areas may require hand spreading.

- 4.4.1. **Weather Conditions.** Place the mixture when the roadway surface temperature is 60°F or higher unless otherwise approved. Place mixtures only when weather conditions and moisture conditions of the roadway surface are suitable in the opinion of the Engineer unless otherwise shown on the plans.
- 4.4.2. **Tack Coat.** Clean the surface before placing the tack coat. Apply tack coat uniformly at the approved rate unless otherwise directed. The Engineer will set the rate between 0.04 and 0.10 gal. of residual asphalt per square yard of surface area. Apply a thin, uniform tack coat to all contact surfaces of curbs, structures, and joints. Prevent splattering of the tack coat when placed adjacent to curb, gutter, and structures. Roll the tack coat with a pneumatic-tire roller when directed.
- 4.5. **Compaction.** Furnish the type, size, and number of rollers required for compaction as approved. Furnish at least one medium pneumatic-tire roller (minimum 12-ton weight). Use the control strip method given in Tex-207-F, Part IV, to establish rolling patterns that achieve maximum compaction. Follow the selected rolling pattern unless changes that affect compaction occur in the mixture or placement conditions. Establish a new rolling pattern when such changes occur. Compact the pavement to the cross-section of the finished paving mixture meeting the requirements of the plans and specifications. Operate vibratory rollers in static

mode when not compacting, changing directions, or when the plan depth of the pavement mat is less than 1-1/2 in. unless otherwise directed.

Start by first rolling the joint with the adjacent pavement and then continue by rolling longitudinally at the sides when rolling with 3-wheel tandem or vibratory rollers. Proceed toward the center of the pavement, overlapping on successive trips by at least 1 ft., unless otherwise directed. Make alternate trips of the roller slightly different in length. Begin rolling at the low side on superelevated curves and progress toward the high side unless otherwise directed.

Avoid displacement of the mixture. Correct any displacement that may occur to the satisfaction of the Engineer. Ensure pavement is fully compacted before allowing rollers to stand on the pavement. Use only water or an approved release agent on rollers, tamps, and other compaction equipment unless otherwise directed. Keep diesel, gasoline, oil, grease, and other foreign matter off the mixture.

Use tamps to thoroughly compact the edges of the pavement along curbs, headers, and similar structures and in locations that will not allow thorough compaction with the rollers. The Engineer may require rolling with a trench roller on widened areas, in trenches, and in other limited areas.

Allow the compacted pavement to cool to 160°F or lower before opening to traffic unless otherwise directed. Sprinkle the finished mat with water or limewater, when directed, to expedite opening the roadway to traffic.

- 4.6. **Production Testing and Operational Tolerances.** The aggregate gradation and the asphalt binder content of the produced mixture must not vary from the JMF by more than the percentage point tolerances shown in Table 6. The gradation of the produced mixture may fall outside the master grading limits for any of the sieve sizes from the 1-1/2 in. through the No. 50 sieve if it is within the JMF tolerances. The aggregate gradation of the No. 200 sieve may not exceed the master gradations shown in Table 4. Any sieve size shown in Table 4 with 100% passing requirements will be allowed a 2% tolerance before the material is considered out of specification.

The Engineer may allow alternate methods for determining the asphalt content and aggregate gradation if the aggregate mineralogy is such that Tex-236-F does not yield reliable results. Provide evidence to the Engineer that results from Tex-236-F are not reliable before an alternate method will be allowed. Use the applicable test procedure as directed if an alternate test method is allowed.

Cease production if 3 consecutive tests indicate that the material produced exceeds the tolerances shown in Table 6 for any individual sieve or laboratory-molded density until corrective actions are taken and the results approved. Cease production if 2 consecutive tests indicate that the asphalt binder content tolerances shown in Table 6 are exceeded until corrective actions are taken and the results approved.

Cease production if the Hveem stability shown in Table 5 is not met for 3 consecutive tests until corrective actions are taken and the results approved.

Table 6
Operational Tolerances

Property	Test Method	Operational Tolerance From JMF
Individual % retained for sieve sizes smaller than 1-1/2" and larger than #8	Tex-200-F	±5.0
Individual % retained for sieve sizes smaller than #8		±3.0
Asphalt binder content, %	Tex-236-F	±0.3
Laboratory-molded density, %	Tex-207-F	±1.0

- 4.7. **Irregularities.** Immediately take corrective action if surface irregularities, including segregation, rutting, raveling, flushing, fat spots, mat slippage, color, texture, roller marks, tears, gouges, streaks, or uncoated aggregate particles are detected. The Engineer may suspend production or placement operations until the problem is corrected.

Remove and replace any mixture that does not bond to the existing pavement or has other surface irregularities identified above at the expense of the Contractor and to the satisfaction of the Engineer.

- 4.8. **Ride Quality.** Use Surface Test Type A to evaluate ride quality in accordance with Item 585, "Ride Quality for Pavement Surfaces," unless otherwise shown on the plans.

5. MEASUREMENT

This Item will be measured by the ton of composite asphalt concrete mixture of the type used in the completed and accepted work. Measure the weight on scales in accordance with Item 520, "Weighing and Measuring Equipment."

For mixture produced by a weigh-batch plant or a modified weigh-batch plant, measurement will be determined on the batch scales unless surge-storage or stockpiling is used. Keep records of the number of batches, batch design, and the weight of the composite asphalt concrete mixture. The composite asphalt concrete mixture is defined as the asphalt, primer, aggregate, additives, and any residual moisture that is not designated to be deducted. Where surge-storage or stockpiling is used, measurement of the material taken from the surge-storage bin or stockpile will be made on truck scales or suspended hopper scales.

6. PAYMENT

The work performed and materials furnished in accordance with this Item and measured as provided under Article 334.5., "Measurement," will be paid for at the unit bid price for "Hot-Mix Cold-Laid Asphalt Concrete Pavement" of the mixture type, SAC, and asphalt binder specified.

This price is full compensation for surface preparation, materials including tack coat, placement, equipment, labor, tools, and incidentals.

Payment adjustment for ride quality, when required, will be determined in accordance with Item 585, "Ride Quality for Pavement Surfaces."

Item 340

Dense-Graded Hot-Mix Asphalt (Small Quantity)



1. DESCRIPTION

Construct a hot-mix asphalt (HMA) pavement layer composed of a compacted, dense-graded mixture of aggregate and asphalt binder mixed hot in a mixing plant. This specification is intended for small quantity (SQ) HMA projects, typically under 5,000 tons total production.

2. MATERIALS

Furnish uncontaminated materials of uniform quality that meet the requirements of the plans and specifications.

Notify the Engineer of all material sources and before changing any material source or formulation. The Engineer will verify that the specification requirements are met when the Contractor makes a source or formulation change, and may require a new laboratory mixture design, trial batch, or both. The Engineer may sample and test project materials at any time during the project to verify specification compliance in accordance with Item 6, "Control of Materials."

- 2.1. **Aggregate.** Furnish aggregates from sources that conform to the requirements shown in Table 1 and as specified in this Section. Aggregate requirements in this Section, including those shown in Table 1, may be modified or eliminated when shown on the plans. Additional aggregate requirements may be specified when shown on the plans. Provide aggregate stockpiles that meet the definitions in this Section for coarse, intermediate, or fine aggregate. Aggregate from reclaimed asphalt pavement (RAP) is not required to meet Table 1 requirements unless otherwise shown on the plans. Supply aggregates that meet the definitions in Tex-100-E for crushed gravel or crushed stone. The Engineer will designate the plant or the quarry as the sampling location. Provide samples from materials produced for the project. The Engineer will establish the Surface Aggregate Classification (SAC) and perform Los Angeles abrasion, magnesium sulfate soundness, and Micro-Deval tests. Perform all other aggregate quality tests listed in Table 1. Document all test results on the mixture design report. The Engineer may perform tests on independent or split samples to verify Contractor test results. Stockpile aggregates for each source and type separately. Determine aggregate gradations for mixture design and production testing based on the washed sieve analysis given in Tex-200-F, Part II.

- 2.1.1. **Coarse Aggregate.** Coarse aggregate stockpiles must have no more than 20% material passing the No. 8 sieve. Aggregates from sources listed in the Department's *Bituminous Rated Source Quality Catalog* (BRSQC) are preapproved for use. Use only the rated values for hot-mix listed in the BRSQC. Rated values for surface treatment (ST) do not apply to coarse aggregate sources used in hot-mix asphalt.

For sources not listed on the Department's BRSQC:

- build an individual stockpile for each material;
- request the Department test the stockpile for specification compliance; and
- once approved, do not add material to the stockpile unless otherwise approved.

Provide aggregate from non-listed sources only when tested by the Engineer and approved before use. Allow 30 calendar days for the Engineer to sample, test, and report results for non-listed sources.

Provide coarse aggregate with at least the minimum SAC shown on the plans. SAC requirements only apply to aggregates used on the surface of travel lanes. SAC requirements apply to aggregates used on surfaces other than travel lanes when shown on the plans. The SAC for sources on the Department's *Aggregate Quality Monitoring Program* (AQMP) (Tex-499-A) is listed in the BRSQC.

- 2.1.1.1. **Blending Class A and Class B Aggregates.** Class B aggregate meeting all other requirements in Table 1 may be blended with a Class A aggregate to meet requirements for Class A materials. Ensure that at least 50% by weight, or volume if required, of the material retained on the No. 4 sieve comes from the Class A aggregate source when blending Class A and B aggregates to meet a Class A requirement. Blend by volume if the bulk specific gravities of the Class A and B aggregates differ by more than 0.300. Coarse aggregate from RAP and Recycled Asphalt Shingles (RAS) will be considered as Class B aggregate for blending purposes.

The Engineer may perform tests at any time during production, when the Contractor blends Class A and B aggregates to meet a Class A requirement, to ensure that at least 50% by weight, or volume if required, of the material retained on the No. 4 sieve comes from the Class A aggregate source. The Engineer will use the Department's mix design template, when electing to verify conformance, to calculate the percent of Class A aggregate retained on the No. 4 sieve by inputting the bin percentages shown from readouts in the control room at the time of production and stockpile gradations measured at the time of production. The Engineer may determine the gradations based on either washed or dry sieve analysis from samples obtained from individual aggregate cold feed bins or aggregate stockpiles. The Engineer may perform spot checks using the gradations supplied by the Contractor on the mixture design report as an input for the template; however, a failing spot check will require confirmation with a stockpile gradation determined by the Engineer.

- 2.1.2. **Intermediate Aggregate.** Aggregates not meeting the definition of coarse or fine aggregate will be defined as intermediate aggregate. Supply intermediate aggregates, when used that are free from organic impurities.

The Engineer may test the intermediate aggregate in accordance with Tex-408-A to verify the material is free from organic impurities. Supply intermediate aggregate from coarse aggregate sources, when used that meet the requirements shown in Table 1 unless otherwise approved.

Test the stockpile if 10% or more of the stockpile is retained on the No. 4 sieve, and verify that it meets the requirements in Table 1 for crushed face count (Tex-460-A) and flat and elongated particles (Tex-280-F).

- 2.1.3. **Fine Aggregate.** Fine aggregates consist of manufactured sands, screenings, and field sands. Fine aggregate stockpiles must meet the gradation requirements in Table 2. Supply fine aggregates that are free from organic impurities. The Engineer may test the fine aggregate in accordance with Tex-408-A to verify the material is free from organic impurities. No more than 15% of the total aggregate may be field sand or other uncrushed fine aggregate. Use fine aggregate, with the exception of field sand, from coarse aggregate sources that meet the requirements shown in Table 1 unless otherwise approved.

Test the stockpile if 10% or more of the stockpile is retained on the No. 4 sieve, and verify that it meets the requirements in Table 1 for crushed face count (Tex-460-A) and flat and elongated particles (Tex-280-F).

Table 1
Aggregate Quality Requirements

Property	Test Method	Requirement
Coarse Aggregate		
SAC	Tex-499-A (AQMP)	As shown on the plans
Deleterious material, %, Max	Tex-217-F, Part I	1.5
Decantation, %, Max	Tex-217-F, Part II	1.5
Micro-Deval abrasion, %	Tex-461-A	Note ¹
Los Angeles abrasion, %, Max	Tex-410-A	40
Magnesium sulfate soundness, 5 cycles, %, Max	Tex-411-A	30
Crushed face count, ² %, Min	Tex-460-A, Part I	85
Flat and elongated particles @ 5:1, %, Max	Tex-280-F	10
Fine Aggregate		
Linear shrinkage, %, Max	Tex-107-E	3
Combined Aggregate³		
Sand equivalent, %, Min	Tex-203-F	45

1. Not used for acceptance purposes. Optional test used by the Engineer as an indicator of the need for further investigation.
2. Only applies to crushed gravel.
3. Aggregates, without mineral filler, RAP, RAS, or additives, combined as used in the job-mix formula (JMF).

Table 2
Gradation Requirements for Fine Aggregate

Sieve Size	% Passing by Weight or Volume
3/8"	100
#8	70-100
#200	0-30

- 2.2. **Mineral Filler.** Mineral filler consists of finely divided mineral matter such as agricultural lime, crusher fines, hydrated lime, or fly ash. Mineral filler is allowed unless otherwise shown on the plans. Use no more than 2% hydrated lime or fly ash unless otherwise shown on the plans. Use no more than 1% hydrated lime if a substitute binder is used unless otherwise shown on the plans or allowed. Test all mineral fillers except hydrated lime and fly ash in accordance with Tex-107-E to ensure specification compliance. The plans may require or disallow specific mineral fillers. Provide mineral filler, when used, that:
- is sufficiently dry, free-flowing, and free from clumps and foreign matter as determined by the Engineer;
 - does not exceed 3% linear shrinkage when tested in accordance with Tex-107-E; and
 - meets the gradation requirements in Table 3.

Table 3
Gradation Requirements for Mineral Filler

Sieve Size	% Passing by Weight or Volume
#8	100
#200	55-100

- 2.3. **Baghouse Fines.** Fines collected by the baghouse or other dust-collecting equipment may be reintroduced into the mixing drum.
- 2.4. **Asphalt Binder.** Furnish the type and grade of performance-graded (PG) asphalt specified on the plans.
- 2.5. **Tack Coat.** Furnish CSS-1H, SS-1H, or a PG binder with a minimum high-temperature grade of PG 58 for tack coat binder in accordance with Item 300, "Asphalts, Oils, and Emulsions." Specialized or preferred tack coat materials may be allowed or required when shown on the plans. Do not dilute emulsified asphalts at the terminal, in the field, or at any other location before use.

The Engineer will obtain at least one sample of the tack coat binder per project in accordance with Tex-500-C, Part III, and test it to verify compliance with Item 300, "Asphalts, Oils, and Emulsions." The Engineer will obtain the sample from the asphalt distributor immediately before use.

- 2.6. **Additives.** Use the type and rate of additive specified when shown on the plans. Additives that facilitate mixing, compaction, or improve the quality of the mixture are allowed when approved. Provide the Engineer

with documentation, such as the bill of lading, showing the quantity of additives used in the project unless otherwise directed.

2.6.1. **Lime and Liquid Antistripping Agent.** When lime or a liquid antistripping agent is used, add in accordance with Item 301, "Asphalt Antistripping Agents." Do not add lime directly into the mixing drum of any plant where lime is removed through the exhaust stream unless the plant has a baghouse or dust collection system that reintroduces the lime into the drum.

2.6.2. **Warm Mix Asphalt (WMA).** Warm Mix Asphalt (WMA) is defined as HMA that is produced within a target temperature discharge range of 215°F and 275°F using approved WMA additives or processes from the Department's MPL.

WMA is allowed for use on all projects and is required when shown on the plans. When WMA is required, the maximum placement or target discharge temperature for WMA will be set at a value below 275°F.

Department-approved WMA additives or processes may be used to facilitate mixing and compaction of HMA produced at target discharge temperatures above 275°F; however, such mixtures will not be defined as WMA.

2.7. **Recycled Materials.** Use of RAP and RAS is permitted unless otherwise shown on the plans. Do not exceed the maximum allowable percentages of RAP and RAS shown in Table 4. The allowable percentages shown in Table 4 may be decreased or increased when shown on the plans. Determine asphalt binder content and gradation of the RAP and RAS stockpiles for mixture design purposes in accordance with Tex-236-F. The Engineer may verify the asphalt binder content of the stockpiles at any time during production. Perform other tests on RAP and RAS when shown on the plans. Asphalt binder from RAP and RAS is designated as recycled asphalt binder. Calculate and ensure that the ratio of the recycled asphalt binder to total binder does not exceed the percentages shown in Table 5 during mixture design and HMA production when RAP or RAS is used. Use a separate cold feed bin for each stockpile of RAP and RAS during HMA production.

Surface, intermediate, and base mixes referenced in Tables 4 and 5 are defined as follows:

- **Surface.** The final HMA lift placed at or near the top of the pavement structure;
- **Intermediate.** Mixtures placed below an HMA surface mix and less than or equal to 8.0 in. from the riding surface; and
- **Base.** Mixtures placed greater than 8.0 in. from the riding surface.

2.7.1. **RAP.** RAP is salvaged, milled, pulverized, broken, or crushed asphalt pavement. Crush or break RAP so that 100% of the particles pass the 2 in. sieve. Fractionated RAP is defined as 2 or more RAP stockpiles, divided into coarse and fine fractions.

Use of Contractor-owned RAP, including HMA plant waste, is permitted unless otherwise shown on the plans. Department-owned RAP stockpiles are available for the Contractor's use when the stockpile locations are shown on the plans. If Department-owned RAP is available for the Contractor's use, the Contractor may use Contractor-owned fractionated RAP and replace it with an equal quantity of Department-owned RAP. This allowance does not apply to a Contractor using unfractionated RAP. Department-owned RAP generated through required work on the Contract is available for the Contractor's use when shown on the plans. Perform any necessary tests to ensure Contractor- or Department-owned RAP is appropriate for use. The Department will not perform any tests or assume any liability for the quality of the Department-owned RAP unless otherwise shown on the plans. The Contractor will retain ownership of RAP generated on the project when shown on the plans.

The coarse RAP stockpile will contain only material retained by processing over a 3/8-in. or 1/2-in. screen unless otherwise approved. The fine RAP stockpile will contain only material passing the 3/8-in. or 1/2-in. screen unless otherwise approved. The Engineer may allow the Contractor to use an alternate to the 3/8-in. or 1/2-in. screen to fractionate the RAP. The maximum percentages of fractionated RAP may be comprised of coarse or fine fractionated RAP or the combination of both coarse and fine fractionated RAP.

Do not use Department- or Contractor-owned RAP contaminated with dirt or other objectionable materials. Do not use Department- or Contractor-owned RAP if the decantation value exceeds 5% and the plasticity index is greater than 8. Test the stockpiled RAP for decantation in accordance with Tex-406-A, Part I. Determine the plasticity index in accordance with Tex-106-E if the decantation value exceeds 5%. The decantation and plasticity index requirements do not apply to RAP samples with asphalt removed by extraction or ignition.

Do not intermingle Contractor-owned RAP stockpiles with Department-owned RAP stockpiles. Remove unused Contractor-owned RAP material from the project site upon completion of the project. Return unused Department-owned RAP to the designated stockpile location.

Table 4
Maximum Allowable Amounts of RAP¹

Maximum Allowable Fractionated RAP ² (%)			Maximum Allowable Unfractionated RAP ³ (%)		
Surface	Intermediate	Base	Surface	Intermediate	Base
20.0	30.0	40.0	10.0	10.0	10.0

1. Must also meet the recycled binder to total binder ratio shown in Table 5.
2. Up to 5% RAS may be used separately or as a replacement for fractionated RAP.
3. Unfractionated RAP may not be combined with fractionated RAP or RAS.

2.7.2.

RAS. Use of post-manufactured RAS or post-consumer RAS (tear-offs) is permitted unless otherwise shown on the plans. Up to 5% RAS may be used separately or as a replacement for fractionated RAP in accordance with Table 4 and Table 5. RAS is defined as processed asphalt shingle material from manufacturing of asphalt roofing shingles or from re-roofing residential structures. Post-manufactured RAS is processed manufacturer's shingle scrap by-product. Post-consumer RAS is processed shingle scrap removed from residential structures. Comply with all regulatory requirements stipulated for RAS by the TCEQ. RAS may be used separately or in conjunction with RAP.

Process the RAS by ambient grinding or granulating such that 100% of the particles pass the 3/8 in. sieve when tested in accordance with Tex-200-F, Part I. Perform a sieve analysis on processed RAS material before extraction (or ignition) of the asphalt binder.

Add sand meeting the requirements of Table 1 and Table 2 or fine RAP to RAS stockpiles if needed to keep the processed material workable. Any stockpile that contains RAS will be considered a RAS stockpile and be limited to no more than 5.0% of the HMA mixture in accordance with Table 4.

Certify compliance of the RAS with DMS-11000, "Evaluating and Using Nonhazardous Recyclable Materials Guidelines." Treat RAS as an established nonhazardous recyclable material if it has not come into contact with any hazardous materials. Use RAS from shingle sources on the Department's MPL. Remove substantially all materials before use that are not part of the shingle, such as wood, paper, metal, plastic, and felt paper. Determine the deleterious content of RAS material for mixture design purposes in accordance with Tex-217-F, Part III. Do not use RAS if deleterious materials are more than 0.5% of the stockpiled RAS unless otherwise approved. Submit a sample for approval before submitting the mixture design. The Department will perform the testing for deleterious material of RAS to determine specification compliance.

2.8.

Substitute Binders. Unless otherwise shown on the plans, the Contractor may use a substitute PG binder listed in Table 5 instead of the PG binder originally specified, if the substitute PG binder and mixture made with the substitute PG binder meet the following:

- the substitute binder meets the specification requirements for the substitute binder grade in accordance with Section 300.2.10., "Performance-Graded Binders;" and
- the mixture has less than 10.0 mm of rutting on the Hamburg Wheel test (Tex-242-F) after the number of passes required for the originally specified binder. Use of substitute PG binders may only be allowed at the discretion of the Engineer if the Hamburg Wheel test results are between 10.0 mm and 12.5 mm.

Table 5
Allowable Substitute PG Binders and Maximum Recycled Binder Ratios

Originally Specified PG Binder	Allowable Substitute PG Binder	Maximum Ratio of Recycled Binder ¹ to Total Binder (%)		
		Surface	Intermediate	Base
HMA				
76-22 ²	70-22 or 64-22	20.0	20.0	20.0
	70-28 or 64-28	30.0	35.0	40.0
70-22 ²	64-22	20.0	20.0	20.0
	64-28 or 58-28	30.0	35.0	40.0
64-22 ²	58-28	30.0	35.0	40.0
76-28 ²	70-28 or 64-28	20.0	20.0	20.0
	64-34	30.0	35.0	40.0
70-28 ²	64-28 or 58-28	20.0	20.0	20.0
	64-34 or 58-34	30.0	35.0	40.0
64-28 ²	58-28	20.0	20.0	20.0
	58-34	30.0	35.0	40.0
WMA³				
76-22 ²	70-22 or 64-22	30.0	35.0	40.0
70-22 ²	64-22 or 58-28	30.0	35.0	40.0
64-22 ⁴	58-28	30.0	35.0	40.0
76-28 ²	70-28 or 64-28	30.0	35.0	40.0
70-28 ²	64-28 or 58-28	30.0	35.0	40.0
64-28 ⁴	58-28	30.0	35.0	40.0

1. Combined recycled binder from RAP and RAS.
2. Use no more than 20.0% recycled binder when using this originally specified PG binder.
3. WMA as defined in Section 340.2.6.2., "Warm Mix Asphalt (WMA)."
4. When used with WMA, this originally specified PG binder is allowed for use at the maximum recycled binder ratios shown in this table.

3. EQUIPMENT

Provide required or necessary equipment in accordance with Item 320, "Equipment for Asphalt Concrete Pavement."

4. CONSTRUCTION

Produce, haul, place, and compact the specified paving mixture. In addition to tests required by the specification, Contractors may perform other QC tests as deemed necessary. At any time during the project, the Engineer may perform production and placement tests as deemed necessary in accordance with Item 5, "Control of the Work." Schedule and participate in a pre-paving meeting with the Engineer on or before the first day of paving unless otherwise directed.

- 4.1. **Certification.** Personnel certified by the Department-approved hot-mix asphalt certification program must conduct all mixture designs, sampling, and testing in accordance with Table 6. Supply the Engineer with a list of certified personnel and copies of their current certificates before beginning production and when personnel changes are made. Provide a mixture design developed and signed by a Level 2 certified specialist.

Table 6
Test Methods, Test Responsibility, and Minimum Certification Levels

Test Description	Test Method	Contractor	Engineer	Level ¹
1. Aggregate and Recycled Material Testing				
Sampling	Tex-221-F	✓	✓	1A
Dry sieve	Tex-200-F, Part I	✓	✓	1A
Washed sieve	Tex-200-F, Part II	✓	✓	1A
Deleterious material	Tex-217-F, Parts I & III	✓	✓	1A
Decantation	Tex-217-F, Part II	✓	✓	1A
Los Angeles abrasion	Tex-410-A		✓	TxDOT
Magnesium sulfate soundness	Tex-411-A		✓	TxDOT
Micro-Deval abrasion	Tex-461-A		✓	2
Crushed face count	Tex-460-A	✓	✓	2
Flat and elongated particles	Tex-280-F	✓	✓	2
Linear shrinkage	Tex-107-E	✓	✓	2
Sand equivalent	Tex-203-F	✓	✓	2
Organic impurities	Tex-408-A	✓	✓	2
2. Asphalt Binder & Tack Coat Sampling				
Asphalt binder sampling	Tex-500-C, Part II	✓	✓	1A/1B
Tack coat sampling	Tex-500-C, Part III	✓	✓	1A/1B
3. Mix Design & Verification				
Design and JMF changes	Tex-204-F	✓	✓	2
Mixing	Tex-205-F	✓	✓	2
Molding (TGC)	Tex-206-F	✓	✓	1A
Molding (SGC)	Tex-241-F	✓	✓	1A
Laboratory-molded density	Tex-207-F	✓	✓	1A
VMA ² (calculation only)	Tex-204-F	✓	✓	2
Rice gravity	Tex-227-F	✓	✓	1A
Ignition oven correction factors ³	Tex-236-F	✓	✓	2
Indirect tensile strength	Tex-226-F	✓	✓	2
Hamburg Wheel test	Tex-242-F	✓	✓	2
Boil test	Tex-530-C	✓	✓	1A
4. Production Testing				
Mixture sampling	Tex-222-F	✓	✓	1A
Molding (TGC)	Tex-206-F		✓	1A
Molding (SGC)	Tex-241-F		✓	1A
Laboratory-molded density	Tex-207-F		✓	1A
VMA ² (calculation only)	Tex-204-F		✓	1A
Rice gravity	Tex-227-F		✓	1A
Gradation & asphalt binder content ³	Tex-236-F		✓	1A
Moisture content	Tex-212-F		✓	1A
Hamburg Wheel test	Tex-242-F		✓	2
Boil test	Tex-530-C		✓	1A
5. Placement Testing				
Trimming roadway cores	Tex-207-F	✓	✓	1A/1B
In-place air voids	Tex-207-F		✓	1A/1B
Establish rolling pattern	Tex-207-F	✓		1B
Ride quality measurement	Tex-1001-S	✓	✓	Note ⁴

1. Level 1A, 1B, and 2 are certification levels provided by the Hot Mix Asphalt Center certification program.
2. Voids in mineral aggregates.
3. Refer to Section 340.4.8.3., "Production Testing," for exceptions to using an ignition oven.
4. Profiler and operator are required to be certified at the Texas A&M Transportation Institute facility when Surface Test Type B is specified.

4.2.

Reporting, Testing, and Responsibilities. Use Department-provided templates to record and calculate all test data pertaining to the mixture design. The Engineer will use Department templates for any production and placement testing. Obtain the current version of the templates at <http://www.txdot.gov/inside-txdot/forms-publications/consultants-contractors/forms/site-manager.html> or from the Engineer.

The maximum allowable time for the Engineer to exchange test data with the Contractor is as given in Table 7 unless otherwise approved. The Engineer will immediately report to the Contractor any test result that requires suspension of production or placement or that fails to meet the specification requirements.

Subsequent mix placed after test results are available to the Contractor, which require suspension of operations, may be considered unauthorized work. Unauthorized work will be accepted or rejected at the discretion of the Engineer in accordance with Article 5.3., "Conformity with Plans, Specifications, and Special Provisions."

Table 7
Reporting Schedule

Description	Reported By	Reported To	To Be Reported Within
Production Testing			
Gradation	Engineer	Contractor	1 working day of completion of the test
Asphalt binder content			
Laboratory-molded density			
VMA (calculation)			
Hamburg Wheel test			
Moisture content			
Boil test			
Binder tests			
Placement Testing			
In-place air voids	Engineer	Contractor	1 working day of completion of the test ¹

1. 2 days are allowed if cores cannot be dried to constant weight within 1 day.

4.3. Mixture Design.

4.3.1. **Design Requirements.** The Contractor may design the mixture using a Texas Gyrotory Compactor (TGC) or a Superpave Gyrotory Compactor (SGC) unless otherwise shown on the plans. Use the dense-graded design procedure provided in Tex-204-F. Design the mixture to meet the requirements listed in Tables 1, 2, 3, 4, 5, 8, 9, and 10.

4.3.1.1. **Target Laboratory-Molded Density When The TGC Is Used.** Design the mixture at a 96.5% target laboratory-molded density. Increase the target laboratory-molded density to 97.0% or 97.5% at the Contractor's discretion or when shown on the plans or specification.

4.3.1.2. **Design Number of Gyration (Ndesign) When The SGC Is Used.** Design the mixture at 50 gyrations (Ndesign). Use a target laboratory-molded density of 96.0% to design the mixture; however, adjustments can be made to the Ndesign value as noted in Table 9. The Ndesign level may be reduced to no less than 35 gyrations at the Contractor's discretion.

Use an approved laboratory from the Department's MPL to perform the Hamburg Wheel test in accordance with Tex-242-F, and provide results with the mixture design, or provide the laboratory mixture and request that the Department perform the Hamburg Wheel test. The Engineer will be allowed 10 working days to provide the Contractor with Hamburg Wheel test results on the laboratory mixture design.

The Engineer will provide the mixture design when shown on the plans. The Contractor may submit a new mixture design at any time during the project. The Engineer will verify and approve all mixture designs (JMF1) before the Contractor can begin production.

Provide the Engineer with a mixture design report using the Department-provided template. Include the following items in the report:

- the combined aggregate gradation, source, specific gravity, and percent of each material used;
- asphalt binder content and aggregate gradation of RAP and RAS stockpiles;
- the target laboratory-molded density (or Ndesign level when using the SGC);
- results of all applicable tests;

- the mixing and molding temperatures;
- the signature of the Level 2 person or persons that performed the design;
- the date the mixture design was performed; and
- a unique identification number for the mixture design.

Table 8
Master Gradation Limits (% Passing by Weight or Volume) and VMA Requirements

Sieve Size	A Coarse Base	B Fine Base	C Coarse Surface	D Fine Surface	F Fine Mixture
2"	100.0 ¹	–	–	–	–
1-1/2"	98.0–100.0	100.0 ¹	–	–	–
1"	78.0–94.0	98.0–100.0	100.0 ¹	–	–
3/4"	64.0–85.0	84.0–98.0	95.0–100.0	100.0 ¹	–
1/2"	50.0–70.0	–	–	98.0–100.0	100.0 ¹
3/8"	–	60.0–80.0	70.0–85.0	85.0–100.0	98.0–100.0
#4	30.0–50.0	40.0–60.0	43.0–63.0	50.0–70.0	70.0–90.0
#8	22.0–36.0	29.0–43.0	32.0–44.0	35.0–46.0	38.0–48.0
#30	8.0–23.0	13.0–28.0	14.0–28.0	15.0–29.0	12.0–27.0
#50	3.0–19.0	6.0–20.0	7.0–21.0	7.0–20.0	6.0–19.0
#200	2.0–7.0	2.0–7.0	2.0–7.0	2.0–7.0	2.0–7.0
Design VMA, % Minimum					
–	12.0	13.0	14.0	15.0	16.0
Production (Plant-Produced) VMA, % Minimum					
–	11.5	12.5	13.5	14.5	15.5

1. Defined as maximum sieve size. No tolerance allowed.

Table 9
Laboratory Mixture Design Properties

Mixture Property	Test Method	Requirement
Target laboratory-molded density, % (TGC)	Tex-207-F	96.5 ¹
Design gyrations (N _{design} for SGC)	Tex-241-F	50 ²
Indirect tensile strength (dry), psi	Tex-226-F	85–200 ³
Boil test ⁴	Tex-530-C	–

1. Increase to 97.0% or 97.5% at the Contractor's discretion or when shown on the plans or specification.
2. Adjust within a range of 35–100 gyrations when shown on the plans or specification or when mutually agreed between the Engineer and Contractor.
3. The Engineer may allow the IDT strength to exceed 200 psi if the corresponding Hamburg Wheel rut depth is greater than 3.0 mm and less than 12.5 mm.
4. Used to establish baseline for comparison to production results. May be waived when approved.

Table 10
Hamburg Wheel Test Requirements

High-Temperature Binder Grade	Test Method	Minimum # of Passes @ 12.5 mm ¹ Rut Depth, Tested @ 50°C
PG 64 or lower	Tex-242-F	10,000 ²
PG 70		15,000 ³
PG 76 or higher		20,000

1. When the rut depth at the required minimum number of passes is less than 3 mm, the Engineer may require the Contractor to increase the target laboratory-molded density (TGC) by 0.5% to no more than 97.5% or lower the N_{design} level (SGC) to no less than 35 gyrations.
2. May be decreased to no less than 5,000 passes when shown on the plans.
3. May be decreased to no less than 10,000 passes when shown on the plans.

4.3.2.

Job-Mix Formula Approval. The job-mix formula (JMF) is the combined aggregate gradation, target laboratory-molded density (or N_{design} level), and target asphalt percentage used to establish target values for hot-mix production. JMF1 is the original laboratory mixture design used to produce the trial batch. When

WMA is used, JMF1 may be designed and submitted to the Engineer without including the WMA additive. When WMA is used, document the additive or process used and recommended rate on the JMF1 submittal. Furnish a mix design report (JMF1) with representative samples of all component materials and request approval to produce the trial batch. Provide approximately 10,000 g of the design mixture and request that the Department perform the Hamburg Wheel test if opting to have the Department perform the test. The Engineer will verify JMF1 based on plant-produced mixture from the trial batch unless otherwise determined. The Engineer may accept an existing mixture design previously used on a Department project and may waive the trial batch to verify JMF1. Provide split samples of the mixtures and blank samples used to determine the ignition oven correction factors. The Engineer will determine the aggregate and asphalt correction factors from the ignition oven used for production testing in accordance with Tex-236-F.

The Engineer will use a TGC calibrated in accordance with Tex-914-K in molding production samples. Provide an SGC at the Engineer's field laboratory for use in molding production samples if the SGC is used to design the mix.

The Engineer may perform Tex-530-C and retain the tested sample for comparison purposes during production. The Engineer may waive the requirement for the boil test.

4.3.3. **JMF Adjustments.** If JMF adjustments are necessary to achieve the specified requirements, the adjusted JMF must:

- be provided to the Engineer in writing before the start of a new lot;
- be numbered in sequence to the previous JMF;
- meet the mixture requirements in Table 4 and Table 5;
- meet the master gradation limits shown in Table 8; and
- be within the operational tolerances of the current JMF listed in Table 11.

The Engineer may adjust the asphalt binder content to maintain desirable laboratory density near the optimum value while achieving other mix requirements.

Table 11
Operational Tolerances

Description	Test Method	Allowable Difference Between Trial Batch and JMF1 Target	Allowable Difference from Current JMF Target
Individual % retained for #8 sieve and larger	Tex-200-F or Tex-236-F	Must be within master grading limits in Table 8	±5.0 ^{1,2}
Individual % retained for sieves smaller than #8 and larger than #200			±3.0 ^{1,2}
% passing the #200 sieve			±2.0 ^{1,2}
Asphalt binder content, %	Tex-236-F	±0.5	±0.3 ²
Laboratory-molded density, %	Tex-207-F	±1.0	±1.0
VMA, %, min	Tex-204-F	Note ³	Note ³

1. When within these tolerances, mixture production gradations may fall outside the master grading limits; however, the % passing the #200 will be considered out of tolerance when outside the master grading limits.
2. Only applies to mixture produced for Lot 1 and higher.
3. Mixture is required to meet Table 8 requirements.

4.4. **Production Operations.** Perform a new trial batch when the plant or plant location is changed. Take corrective action and receive approval to proceed after any production suspension for noncompliance to the specification. Submit a new mix design and perform a new trial batch when the asphalt binder content of:

- any RAP stockpile used in the mix is more than 0.5% higher than the value shown on the mixture design report; or
- RAS stockpile used in the mix is more than 2.0% higher than the value shown on the mixture design report.

4.4.1. **Storage and Heating of Materials.** Do not heat the asphalt binder above the temperatures specified in Item 300, "Asphalts, Oils, and Emulsions," or outside the manufacturer's recommended values. Provide the Engineer with daily records of asphalt binder and hot-mix asphalt discharge temperatures (in legible and

discernible increments) in accordance with Item 320, "Equipment for Asphalt Concrete Pavement," unless otherwise directed. Do not store mixture for a period long enough to affect the quality of the mixture, nor in any case longer than 12 hr. unless otherwise approved.

- 4.4.2. **Mixing and Discharge of Materials.** Notify the Engineer of the target discharge temperature and produce the mixture within 25°F of the target. Monitor the temperature of the material in the truck before shipping to ensure that it does not exceed 350°F (or 275°F for WMA) and is not lower than 215°F. The Department will not pay for or allow placement of any mixture produced above 350°F.

Produce WMA within the target discharge temperature range of 215°F and 275°F when WMA is required. Take corrective action any time the discharge temperature of the WMA exceeds the target discharge range. The Engineer may suspend production operations if the Contractor's corrective action is not successful at controlling the production temperature within the target discharge range. Note that when WMA is produced, it may be necessary to adjust burners to ensure complete combustion such that no burner fuel residue remains in the mixture.

Control the mixing time and temperature so that substantially all moisture is removed from the mixture before discharging from the plant. The Engineer may determine the moisture content by oven-drying in accordance with Tex-212-F, Part II, and verify that the mixture contains no more than 0.2% of moisture by weight. The Engineer will obtain the sample immediately after discharging the mixture into the truck, and will perform the test promptly.

- 4.5. **Hauling Operations.** Clean all truck beds before use to ensure that mixture is not contaminated. Use a release agent shown on the Department's MPL to coat the inside bed of the truck when necessary.

Use equipment for hauling as defined in Section 340.4.6.3.2., "Hauling Equipment." Use other hauling equipment only when allowed.

- 4.6. **Placement Operations.** Collect haul tickets from each load of mixture delivered to the project and provide the Department's copy to the Engineer approximately every hour, or as directed. Use a hand-held thermal camera or infrared thermometer to measure and record the internal temperature of the mixture as discharged from the truck or Material Transfer Device (MTD) before or as the mix enters the paver and an approximate station number or GPS coordinates on each ticket unless otherwise directed. Calculate the daily yield and cumulative yield for the specified lift and provide to the Engineer at the end of paving operations for each day unless otherwise directed. The Engineer may suspend production if the Contractor fails to produce and provide haul tickets and yield calculations by the end of paving operations for each day.

Prepare the surface by removing raised pavement markers and objectionable material such as moisture, dirt, sand, leaves, and other loose impediments from the surface before placing mixture. Remove vegetation from pavement edges. Place the mixture to meet the typical section requirements and produce a smooth, finished surface with a uniform appearance and texture. Offset longitudinal joints of successive courses of hot-mix by at least 6 in. Place mixture so that longitudinal joints on the surface course coincide with lane lines, or as directed. Ensure that all finished surfaces will drain properly.

Place the mixture at the rate or thickness shown on the plans. The Engineer will use the guidelines in Table 12 to determine the compacted lift thickness of each layer when multiple lifts are required. The thickness determined is based on the rate of 110 lb./sq. yd. for each inch of pavement unless otherwise shown on the plans.

Table 12
Compacted Lift Thickness and Required Core Height

Mixture Type	Compacted Lift Thickness Guidelines		Minimum Untrimmed Core Height (in.) Eligible for Testing
	Minimum (in.)	Maximum (in.)	
A	3.00	6.00	2.00
B	2.50	5.00	1.75
C	2.00	4.00	1.50
D	1.50	3.00	1.25
F	1.25	2.50	1.25

- 4.6.1. **Weather Conditions.** Place mixture when the roadway surface temperature is at or above 60°F unless otherwise approved. Measure the roadway surface temperature with a hand-held thermal camera or infrared thermometer. The Engineer may allow mixture placement to begin before the roadway surface reaches the required temperature if conditions are such that the roadway surface will reach the required temperature within 2 hr. of beginning placement operations. Place mixtures only when weather conditions and moisture conditions of the roadway surface are suitable as determined by the Engineer. The Engineer may restrict the Contractor from paving if the ambient temperature is likely to drop below 32°F within 12 hr. of paving.
- 4.6.2. **Tack Coat.** Clean the surface before placing the tack coat. The Engineer will set the rate between 0.04 and 0.10 gal. of residual asphalt per square yard of surface area. Apply a uniform tack coat at the specified rate unless otherwise directed. Apply the tack coat in a uniform manner to avoid streaks and other irregular patterns. Apply a thin, uniform tack coat to all contact surfaces of curbs, structures, and all joints. Allow adequate time for emulsion to break completely before placing any material. Prevent splattering of tack coat when placed adjacent to curb, gutter, and structures. Roll the tack coat with a pneumatic-tire roller to remove streaks and other irregular patterns when directed.
- 4.6.3. **Lay-Down Operations.**
- 4.6.3.1. **Windrow Operations.** Operate windrow pickup equipment so that when hot-mix is placed in windrows substantially all the mixture deposited on the roadbed is picked up and loaded into the paver.
- 4.6.3.2. **Hauling Equipment.** Use belly dumps, live bottom, or end dump trucks to haul and transfer mixture; however, with exception of paving miscellaneous areas, end dump trucks are only allowed when used in conjunction with an MTD with remixing capability unless otherwise allowed.
- 4.6.3.3. **Screed Heaters.** Turn off screed heaters, to prevent overheating of the mat, if the paver stops for more than 5 min.
- 4.7. **Compaction.** Compact the pavement uniformly to contain between 3.8% and 8.5% in-place air voids.
- Furnish the type, size, and number of rollers required for compaction as approved. Use a pneumatic-tire roller to seal the surface unless excessive pickup of fines occurs. Use additional rollers as required to remove any roller marks. Use only water or an approved release agent on rollers, tamps, and other compaction equipment unless otherwise directed.
- Use the control strip method shown in Tex-207-F, Part IV, on the first day of production to establish the rolling pattern that will produce the desired in-place air voids unless otherwise directed.
- Use tamps to thoroughly compact the edges of the pavement along curbs, headers, and similar structures and in locations that will not allow thorough compaction with rollers. The Engineer may require rolling with a trench roller on widened areas, in trenches, and in other limited areas.
- Complete all compaction operations before the pavement temperature drops below 160°F unless otherwise allowed. The Engineer may allow compaction with a light finish roller operated in static mode for pavement temperatures below 160°F.

Allow the compacted pavement to cool to 160°F or lower before opening to traffic unless otherwise directed. Sprinkle the finished mat with water or limewater, when directed, to expedite opening the roadway to traffic.

4.8. **Production Acceptance.**

4.8.1. **Production Lot.** Each day of production is defined as a production lot. Lots will be sequentially numbered and correspond to each new day of production. Note that lots are not subdivided into sublots for this specification.

4.8.2. **Production Sampling.**

4.8.2.1. **Mixture Sampling.** The Engineer may obtain mixture samples in accordance with Tex-222-F at any time during production.

4.8.2.2. **Asphalt Binder Sampling.** The Engineer may obtain or require the Contractor to obtain 1 qt. samples of the asphalt binder at any time during production from a port located immediately upstream from the mixing drum or pug mill in accordance with Tex-500-C, Part II. The Engineer may test any of the asphalt binder samples to verify compliance with Item 300, "Asphalts, Oils, and Emulsions."

4.8.3. **Production Testing.** The Engineer will test at the frequency listed in the Department's *Guide Schedule of Sampling and Testing* and this specification. The Engineer may suspend production if production tests do not meet specifications or are not within operational tolerances listed in Table 11. Take immediate corrective action if the Engineer's laboratory-molded density on any sample is less than 95.0% or greater than 98.0%, to bring the mixture within these tolerances. The Engineer may suspend operations if the Contractor's corrective actions do not produce acceptable results. The Engineer will allow production to resume when the proposed corrective action is likely to yield acceptable results.

The Engineer may use alternate methods for determining the asphalt binder content and aggregate gradation if the aggregate mineralogy is such that Tex-236-F does not yield reliable results. Use the applicable test procedure if an alternate test method is selected.

Table 13
Production and Placement Testing

Description	Test Method
Individual % retained for #8 sieve and larger	Tex-200-F or Tex-236-F
Individual % retained for sieves smaller than #8 and larger than #200	
% passing the #200 sieve	
Laboratory-molded density	Tex-207-F
Laboratory-molded bulk specific gravity	
In-Place air voids	
VMA	Tex-204-F
Moisture content	Tex-212-F, Part II
Theoretical maximum specific (Rice) gravity	Tex-227-F
Asphalt binder content	Tex-236-F
Hamburg Wheel test	Tex-242-F
Recycled Asphalt Shingles (RAS) ¹	Tex-217-F, Part III
Asphalt binder sampling and testing	Tex-500-C
Tack coat sampling and testing	Tex-500-C, Part III
Boil test	Tex-530-C

1. Testing performed by the Construction Division or designated laboratory.

4.8.3.1. **Void in Mineral Aggregates (VMA).** The Engineer may determine the VMA for any production lot. Take immediate corrective action if the VMA value for any lot is less than the minimum VMA requirement for production listed in Table 8. Suspend production and shipment of the mixture if the Engineer's VMA result is more than 0.5% below the minimum VMA requirement for production listed in Table 8. In addition to suspending production, the Engineer may require removal and replacement or may allow the lot to be left in place without payment.

- 4.8.3.2. **Hamburg Wheel Test.** The Engineer may perform a Hamburg Wheel test at any time during production, including when the boil test indicates a change in quality from the materials submitted for JMF1. In addition to testing production samples, the Engineer may obtain cores and perform Hamburg Wheel tests on any areas of the roadway where rutting is observed. Suspend production until further Hamburg Wheel tests meet the specified values when the production or core samples fail the Hamburg Wheel test criteria in Table 10. Core samples, if taken, will be obtained from the center of the finished mat or other areas excluding the vehicle wheel paths. The Engineer may require up to the entire lot of any mixture failing the Hamburg Wheel test to be removed and replaced at the Contractor's expense.

If the Department's or Department-approved laboratory's Hamburg Wheel test results in a "remove and replace" condition, the Contractor may request that the Department confirm the results by re-testing the failing material. The Construction Division will perform the Hamburg Wheel tests and determine the final disposition of the material in question based on the Department's test results.

- 4.8.4. **Individual Loads of Hot-Mix.** The Engineer can reject individual truckloads of hot-mix. When a load of hot-mix is rejected for reasons other than temperature, contamination, or excessive uncoated particles, the Contractor may request that the rejected load be tested. Make this request within 4 hr. of rejection. The Engineer will sample and test the mixture. If test results are within the operational tolerances shown in Table 11, payment will be made for the load. If test results are not within operational tolerances, no payment will be made for the load.

4.9. **Placement Acceptance.**

- 4.9.1. **Placement Lot.** A placement lot is defined as the area placed during a production lot (one day's production). Placement lot numbers will correspond with production lot numbers.

- 4.9.2. **Miscellaneous Areas.** Miscellaneous areas include areas that typically involve significant handwork or discontinuous paving operations, such as temporary detours, driveways, mailbox turnouts, crossovers, gores, spot level-up areas, and other similar areas. Miscellaneous areas also include level-ups and thin overlays when the layer thickness specified on the plans is less than the minimum untrimmed core height eligible for testing shown in Table 12. The specified layer thickness is based on the rate of 110 lb./sq. yd. for each inch of pavement unless another rate is shown on the plans. Compact miscellaneous areas in accordance with Section 340.4.7., "Compaction." Miscellaneous areas are not subject to in-place air void determination except for temporary detours when shown on the plans.

- 4.9.3. **Placement Sampling.** Provide the equipment and means to obtain and trim roadway cores on site. On site is defined as in close proximity to where the cores are taken. Obtain the cores within one working day of the time the placement lot is completed unless otherwise approved. Obtain two 6-in. diameter cores side-by-side at each location selected by the Engineer for in-place air void determination unless otherwise shown on the plans. For Type D and Type F mixtures, 4-in. diameter cores are allowed. Mark the cores for identification, measure and record the untrimmed core height, and provide the information to the Engineer. The Engineer will witness the coring operation and measurement of the core thickness.

Visually inspect each core and verify that the current paving layer is bonded to the underlying layer. Take corrective action if an adequate bond does not exist between the current and underlying layer to ensure that an adequate bond will be achieved during subsequent placement operations.

Trim the cores immediately after obtaining the cores from the roadway in accordance with Tex-207-F if the core heights meet the minimum untrimmed value listed in Table 12. Trim the cores on site in the presence of the Engineer. Use a permanent marker or paint pen to record the date and lot number on each core as well as the designation as Core A or B. The Engineer may require additional information to be marked on the core and may choose to sign or initial the core. The Engineer will take custody of the cores immediately after they are trimmed and will retain custody of the cores until the Department's testing is completed. Before turning the trimmed cores over to the Engineer, the Contractor may wrap the trimmed cores or secure them in a manner that will reduce the risk of possible damage occurring during transport by the Engineer. After testing, the Engineer will return the cores to the Contractor.

The Engineer may have the cores transported back to the Department's laboratory at the HMA plant via the Contractor's haul truck or other designated vehicle. In such cases where the cores will be out of the Engineer's possession during transport, the Engineer will use Department-provided security bags and the Roadway Core Custody protocol located at <http://www.txdot.gov/business/specifications.htm> to provide a secure means and process that protects the integrity of the cores during transport.

Instead of the Contractor trimming the cores on site immediately after coring, the Engineer and the Contractor may mutually agree to have the trimming operations performed at an alternate location such as a field laboratory or other similar location. In such cases, the Engineer will take possession of the cores immediately after they are obtained from the roadway and will retain custody of the cores until testing is completed. Either the Department or Contractor representative may perform trimming of the cores. The Engineer will witness all trimming operations in cases where the Contractor representative performs the trimming operation.

Dry the core holes and tack the sides and bottom immediately after obtaining the cores. Fill the hole with the same type of mixture and properly compact the mixture. Repair core holes with other methods when approved.

4.9.4. **Placement Testing.** The Engineer may measure in-place air voids at any time during the project to verify specification compliance.

4.9.4.1. **In-Place Air Voids.** The Engineer will measure in-place air voids in accordance with Tex-207-F and Tex-227-F. Cores not meeting the height requirements in Table 12 will not be tested. Before drying to a constant weight, cores may be pre-dried using a Corelok or similar vacuum device to remove excess moisture. The Engineer will use the corresponding theoretical maximum specific gravity to determine the air void content of each core. The Engineer will use the average air void content of the 2 cores to determine the in-place air voids at the selected location.

The Engineer will use the vacuum method to seal the core if required by Tex-207-F. The Engineer will use the test results from the unsealed core if the sealed core yields a higher specific gravity than the unsealed core. After determining the in-place air void content, the Engineer will return the cores and provide test results to the Contractor.

Take immediate corrective action when the in-place air voids exceed the range of 3.8% and 8.5% to bring the operation within these tolerances. The Engineer may suspend operations or require removal and replacement if the in-place air voids are less than 2.7% or greater than 9.9%. The Engineer will allow paving to resume when the proposed corrective action is likely to yield between 3.8% and 8.5% in-place air voids. Areas defined in Section 340.9.2., "Miscellaneous Areas," are not subject to in-place air void determination.

4.9.5. **Irregularities.** Identify and correct irregularities including segregation, rutting, raveling, flushing, fat spots, mat slippage, irregular color, irregular texture, roller marks, tears, gouges, streaks, uncoated aggregate particles, or broken aggregate particles. The Engineer may also identify irregularities, and in such cases, the Engineer will promptly notify the Contractor. If the Engineer determines that the irregularity will adversely affect pavement performance, the Engineer may require the Contractor to remove and replace (at the Contractor's expense) areas of the pavement that contain irregularities and areas where the mixture does not bond to the existing pavement. If irregularities are detected, the Engineer may require the Contractor to immediately suspend operations or may allow the Contractor to continue operations for no more than one day while the Contractor is taking appropriate corrective action.

4.9.6. **Ride Quality.** Use Surface Test Type A to evaluate ride quality in accordance with Item 585, "Ride Quality for Pavement Surfaces," unless otherwise shown on the plans.

5. MEASUREMENT

Hot mix will be measured by the ton of composite hot-mix, which includes asphalt, aggregate, and additives. Measure the weight on scales in accordance with Item 520, "Weighing and Measuring Equipment."

6. PAYMENT

The work performed and materials furnished in accordance with this Item and measured as provided under Article 340.5., "Measurement," will be paid for at the unit bid price for "Dense Graded Hot-Mix Asphalt (SQ)" of the mixture type, SAC, and binder specified. These prices are full compensation for surface preparation, materials including tack coat, placement, equipment, labor, tools, and incidentals.

Trial batches will not be paid for unless they are included in pavement work approved by the Department.

Payment adjustment for ride quality, if applicable, will be determined in accordance with Item 585, "Ride Quality for Pavement Surfaces."

Item 341

Dense-Graded Hot-Mix Asphalt



1. DESCRIPTION

Construct a hot-mix asphalt (HMA) pavement layer composed of a compacted, dense-graded mixture of aggregate and asphalt binder mixed hot in a mixing plant. Payment adjustments will apply to HMA placed under this specification unless the HMA is deemed exempt in accordance with Section 341.4.9.4., "Exempt Production."

2. MATERIALS

Furnish uncontaminated materials of uniform quality that meet the requirements of the plans and specifications.

Notify the Engineer of all material sources and before changing any material source or formulation. The Engineer will verify that the specification requirements are met when the Contractor makes a source or formulation change, and may require a new laboratory mixture design, trial batch, or both. The Engineer may sample and test project materials at any time during the project to verify specification compliance in accordance with Item 6, "Control of Materials."

- 2.1. **Aggregate.** Furnish aggregates from sources that conform to the requirements shown in Table 1 and as specified in this Section. Aggregate requirements in this Section, including those shown in Table 1, may be modified or eliminated when shown on the plans. Additional aggregate requirements may be specified when shown on the plans. Provide aggregate stockpiles that meet the definitions in this Section for coarse, intermediate, or fine aggregate. Aggregate from reclaimed asphalt pavement (RAP) is not required to meet Table 1 requirements unless otherwise shown on the plans. Supply aggregates that meet the definitions in Tex-100-E for crushed gravel or crushed stone. The Engineer will designate the plant or the quarry as the sampling location. Provide samples from materials produced for the project. The Engineer will establish the Surface Aggregate Classification (SAC) and perform Los Angeles abrasion, magnesium sulfate soundness, and Micro-Deval tests. Perform all other aggregate quality tests listed in Table 1. Document all test results on the mixture design report. The Engineer may perform tests on independent or split samples to verify Contractor test results. Stockpile aggregates for each source and type separately. Determine aggregate gradations for mixture design and production testing based on the washed sieve analysis given in Tex-200-F, Part II.

- 2.1.1. **Coarse Aggregate.** Coarse aggregate stockpiles must have no more than 20% material passing the No. 8 sieve. Aggregates from sources listed in the Department's *Bituminous Rated Source Quality Catalog* (BRSQC) are preapproved for use. Use only the rated values for hot-mix listed in the BRSQC. Rated values for surface treatment (ST) do not apply to coarse aggregate sources used in hot-mix asphalt.

For sources not listed on the Department's BRSQC:

- build an individual stockpile for each material;
- request the Department test the stockpile for specification compliance; and
- once approved, do not add material to the stockpile unless otherwise approved.

Provide aggregate from non-listed sources only when tested by the Engineer and approved before use. Allow 30 calendar days for the Engineer to sample, test, and report results for non-listed sources.

Provide coarse aggregate with at least the minimum SAC shown on the plans. SAC requirements only apply to aggregates used on the surface of travel lanes. SAC requirements apply to aggregates used on surfaces

other than travel lanes when shown on the plans. The SAC for sources on the Department's *Aggregate Quality Monitoring Program (AQMP) (Tex-499-A)* is listed in the BRSQC.

- 2.1.1.1. **Blending Class A and Class B Aggregates.** Class B aggregate meeting all other requirements in Table 1 may be blended with a Class A aggregate to meet requirements for Class A materials. Ensure that at least 50% by weight, or volume if required, of the material retained on the No. 4 sieve comes from the Class A aggregate source when blending Class A and B aggregates to meet a Class A requirement. Blend by volume if the bulk specific gravities of the Class A and B aggregates differ by more than 0.300. Coarse aggregate from RAP and Recycled Asphalt Shingles (RAS) will be considered as Class B aggregate for blending purposes.

The Engineer may perform tests at any time during production, when the Contractor blends Class A and B aggregates to meet a Class A requirement, to ensure that at least 50% by weight, or volume if required, of the material retained on the No. 4 sieve comes from the Class A aggregate source. The Engineer will use the Department's mix design template, when electing to verify conformance, to calculate the percent of Class A aggregate retained on the No. 4 sieve by inputting the bin percentages shown from readouts in the control room at the time of production and stockpile gradations measured at the time of production. The Engineer may determine the gradations based on either washed or dry sieve analysis from samples obtained from individual aggregate cold feed bins or aggregate stockpiles. The Engineer may perform spot checks using the gradations supplied by the Contractor on the mixture design report as an input for the template; however, a failing spot check will require confirmation with a stockpile gradation determined by the Engineer.

- 2.1.1.2. **Micro-Deval Abrasion.** The Engineer will perform a minimum of one Micro-Deval abrasion test in accordance with Tex-461-A for each coarse aggregate source used in the mixture design that has a Rated Source Soundness Magnesium (RSSM) loss value greater than 15 as listed in the BRSQC. The Engineer will perform testing before the start of production and may perform additional testing at any time during production. The Engineer may obtain the coarse aggregate samples from each coarse aggregate source or may require the Contractor to obtain the samples. The Engineer may waive all Micro-Deval testing based on a satisfactory test history of the same aggregate source.

The Engineer will estimate the magnesium sulfate soundness loss for each coarse aggregate source, when tested, using the following formula:

$$Mg_{est.} = (RSSM)(MD_{act.}/RSMD)$$

where:

$Mg_{est.}$ = magnesium sulfate soundness loss

$MD_{act.}$ = actual Micro-Deval percent loss

$RSMD$ = Rated Source Micro-Deval

When the estimated magnesium sulfate soundness loss is greater than the maximum magnesium sulfate soundness loss specified, the coarse aggregate source will not be allowed for use unless otherwise approved. The Engineer will consult the Geotechnical, Soils, and Aggregates Branch of the Construction Division, and additional testing may be required before granting approval.

- 2.1.2. **Intermediate Aggregate.** Aggregates not meeting the definition of coarse or fine aggregate will be defined as intermediate aggregate. Supply intermediate aggregates, when used that are free from organic impurities. The Engineer may test the intermediate aggregate in accordance with Tex-408-A to verify the material is free from organic impurities. Supply intermediate aggregate from coarse aggregate sources, when used that meet the requirements shown in Table 1 unless otherwise approved.

Test the stockpile if 10% or more of the stockpile is retained on the No. 4 sieve, and verify that it meets the requirements in Table 1 for crushed face count (Tex-460-A) and flat and elongated particles (Tex-280-F).

- 2.1.3. **Fine Aggregate.** Fine aggregates consist of manufactured sands, screenings, and field sands. Fine aggregate stockpiles must meet the gradation requirements in Table 2. Supply fine aggregates that are free from organic impurities. The Engineer may test the fine aggregate in accordance with Tex-408-A to verify the

material is free from organic impurities. No more than 15% of the total aggregate may be field sand or other uncrushed fine aggregate. Use fine aggregate, with the exception of field sand, from coarse aggregate sources that meet the requirements shown in Table 1 unless otherwise approved.

Test the stockpile if 10% or more of the stockpile is retained on the No. 4 sieve and verify that it meets the requirements in Table 1 for crushed face count (Tex-460-A) and flat and elongated particles (Tex-280-F).

Table 1
Aggregate Quality Requirements

Property	Test Method	Requirement
Coarse Aggregate		
SAC	Tex-499-A (AQMP)	As shown on the plans
Deleterious material, %, Max	Tex-217-F, Part I	1.5
Decantation, %, Max	Tex-217-F, Part II	1.5
Micro-Deval abrasion, %	Tex-461-A	Note ¹
Los Angeles abrasion, %, Max	Tex-410-A	40
Magnesium sulfate soundness, 5 cycles, %, Max	Tex-411-A	30
Crushed face count, ² %, Min	Tex-460-A, Part I	85
Flat and elongated particles @ 5:1, %, Max	Tex-280-F	10
Fine Aggregate		
Linear shrinkage, %, Max	Tex-107-E	3
Combined Aggregate³		
Sand equivalent, %, Min	Tex-203-F	45

1. Used to estimate the magnesium sulfate soundness loss in accordance with Section 341.2.1.1.2., "Micro-Deval Abrasion."
2. Only applies to crushed gravel.
3. Aggregates, without mineral filler, RAP, RAS, or additives, combined as used in the job-mix formula (JMF).

Table 2
Gradation Requirements for Fine Aggregate

Sieve Size	% Passing by Weight or Volume
3/8"	100
#8	70–100
#200	0–30

- 2.2. **Mineral Filler.** Mineral filler consists of finely divided mineral matter such as agricultural lime, crusher fines, hydrated lime, or fly ash. Mineral filler is allowed unless otherwise shown on the plans. Use no more than 2% hydrated lime or fly ash unless otherwise shown on the plans. Use no more than 1% hydrated lime if a substitute binder is used unless otherwise shown on the plans or allowed. Test all mineral fillers except hydrated lime and fly ash in accordance with Tex-107-E to ensure specification compliance. The plans may require or disallow specific mineral fillers. Provide mineral filler, when used, that:

- is sufficiently dry, free-flowing, and free from clumps and foreign matter as determined by the Engineer;
- does not exceed 3% linear shrinkage when tested in accordance with Tex-107-E; and
- meets the gradation requirements in Table 3.

Table 3
Gradation Requirements for Mineral Filler

Sieve Size	% Passing by Weight or Volume
#8	100
#200	55–100

- 2.3. **Baghouse Fines.** Fines collected by the baghouse or other dust-collecting equipment may be reintroduced into the mixing drum.
- 2.4. **Asphalt Binder.** Furnish the type and grade of performance-graded (PG) asphalt specified on the plans.
- 2.5. **Tack Coat.** Furnish CSS-1H, SS-1H, or a PG binder with a minimum high-temperature grade of PG 58 for tack coat binder in accordance with Item 300, "Asphalts, Oils, and Emulsions." Specialized or preferred tack

coat materials may be allowed or required when shown on the plans. Do not dilute emulsified asphalts at the terminal, in the field, or at any other location before use.

The Engineer will obtain at least one sample of the tack coat binder per project in accordance with Tex-500-C, Part III, and test it to verify compliance with Item 300, "Asphalts, Oils, and Emulsions." The Engineer will obtain the sample from the asphalt distributor immediately before use.

- 2.6. **Additives.** Use the type and rate of additive specified when shown on the plans. Additives that facilitate mixing, compaction, or improve the quality of the mixture are allowed when approved. Provide the Engineer with documentation such as the bill of lading showing the quantity of additives used in the project unless otherwise directed.
- 2.6.1. **Lime and Liquid Antistripping Agent.** When lime or a liquid antistripping agent is used, add in accordance with Item 301, "Asphalt Antistripping Agents." Do not add lime directly into the mixing drum of any plant where lime is removed through the exhaust stream unless the plant has a baghouse or dust collection system that reintroduces the lime into the drum.
- 2.6.2. **Warm Mix Asphalt (WMA).** Warm Mix Asphalt (WMA) is defined as HMA that is produced within a target temperature discharge range of 215°F and 275°F using approved WMA additives or processes from the Department's MPL.

WMA is allowed for use on all projects and is required when shown on the plans. When WMA is required, the maximum placement or target discharge temperature for WMA will be set at a value below 275°F.

Department-approved WMA additives or processes may be used to facilitate mixing and compaction of HMA produced at target discharge temperatures above 275°F; however, such mixtures will not be defined as WMA.

- 2.7. **Recycled Materials.** Use of RAP and RAS is permitted unless otherwise shown on the plans. Do not exceed the maximum allowable percentages of RAP and RAS shown in Table 4. The allowable percentages shown in Table 4 may be decreased or increased when shown on the plans. Determine asphalt binder content and gradation of the RAP and RAS stockpiles for mixture design purposes in accordance with Tex-236-F. The Engineer may verify the asphalt binder content of the stockpiles at any time during production. Perform other tests on RAP and RAS when shown on the plans. Asphalt binder from RAP and RAS is designated as recycled asphalt binder. Calculate and ensure that the ratio of the recycled asphalt binder to total binder does not exceed the percentages shown in Table 5 during mixture design and HMA production when RAP or RAS is used. Use a separate cold feed bin for each stockpile of RAP and RAS during HMA production.

Surface, intermediate, and base mixes referenced in Tables 4 and 5 are defined as follows:

- **Surface.** The final HMA lift placed at or near the top of the pavement structure;
- **Intermediate.** Mixtures placed below an HMA surface mix and less than or equal to 8.0 in. from the riding surface; and
- **Base.** Mixtures placed greater than 8.0 in. from the riding surface.

- 2.7.1. **RAP.** RAP is salvaged, milled, pulverized, broken, or crushed asphalt pavement. Crush or break RAP so that 100% of the particles pass the 2 in. sieve. Fractionated RAP is defined as 2 or more RAP stockpiles, divided into coarse and fine fractions.

Use of Contractor-owned RAP including HMA plant waste is permitted unless otherwise shown on the plans. Department-owned RAP stockpiles are available for the Contractor's use when the stockpile locations are shown on the plans. If Department-owned RAP is available for the Contractor's use, the Contractor may use Contractor-owned fractionated RAP and replace it with an equal quantity of Department-owned RAP. This allowance does not apply to a Contractor using unfractionated RAP. Department-owned RAP generated through required work on the Contract is available for the Contractor's use when shown on the plans. Perform any necessary tests to ensure Contractor- or Department-owned RAP is appropriate for use. The Department will not perform any tests or assume any liability for the quality of the Department-owned RAP

unless otherwise shown on the plans. The Contractor will retain ownership of RAP generated on the project when shown on the plans.

The coarse RAP stockpile will contain only material retained by processing over a 3/8-in. or 1/2-in. screen unless otherwise approved. The fine RAP stockpile will contain only material passing the 3/8-in. or 1/2-in. screen unless otherwise approved. The Engineer may allow the Contractor to use an alternate to the 3/8-in. or 1/2-in. screen to fractionate the RAP. The maximum percentages of fractionated RAP may be comprised of coarse or fine fractionated RAP or the combination of both coarse and fine fractionated RAP.

Do not use Department- or Contractor-owned RAP contaminated with dirt or other objectionable materials. Do not use Department- or Contractor-owned RAP if the decantation value exceeds 5% and the plasticity index is greater than 8. Test the stockpiled RAP for decantation in accordance with Tex-406-A, Part I. Determine the plasticity index in accordance with Tex-106-E if the decantation value exceeds 5%. The decantation and plasticity index requirements do not apply to RAP samples with asphalt removed by extraction or ignition.

Do not intermingle Contractor-owned RAP stockpiles with Department-owned RAP stockpiles. Remove unused Contractor-owned RAP material from the project site upon completion of the project. Return unused Department-owned RAP to the designated stockpile location.

Table 4
Maximum Allowable Amounts of RAP¹

Maximum Allowable Fractionated RAP ² (%)			Maximum Allowable Unfractionated RAP ³ (%)		
Surface	Intermediate	Base	Surface	Intermediate	Base
20.0	30.0	40.0	10.0	10.0	10.0

1. Must also meet the recycled binder to total binder ratio shown in Table 5.
2. Up to 5% RAS may be used separately or as a replacement for fractionated RAP.
3. Unfractionated RAP may not be combined with fractionated RAP or RAS.

2.7.2.

RAS. Use of post-manufactured RAS or post-consumer RAS (tear-offs) is permitted unless otherwise shown on the plans. Up to 5% RAS may be used separately or as a replacement for fractionated RAP in accordance with Table 4 and Table 5. RAS is defined as processed asphalt shingle material from manufacturing of asphalt roofing shingles or from re-roofing residential structures. Post-manufactured RAS is processed manufacturer's shingle scrap by-product. Post-consumer RAS is processed shingle scrap removed from residential structures. Comply with all regulatory requirements stipulated for RAS by the TCEQ. RAS may be used separately or in conjunction with RAP.

Process the RAS by ambient grinding or granulating such that 100% of the particles pass the 3/8 in. sieve when tested in accordance with Tex-200-F, Part I. Perform a sieve analysis on processed RAS material before extraction (or ignition) of the asphalt binder.

Add sand meeting the requirements of Table 1 and Table 2 or fine RAP to RAS stockpiles if needed to keep the processed material workable. Any stockpile that contains RAS will be considered a RAS stockpile and be limited to no more than 5.0% of the HMA mixture in accordance with Table 4.

Certify compliance of the RAS with DMS-11000, "Evaluating and Using Nonhazardous Recyclable Materials Guidelines." Treat RAS as an established nonhazardous recyclable material if it has not come into contact with any hazardous materials. Use RAS from shingle sources on the Department's MPL. Remove substantially all materials before use that are not part of the shingle, such as wood, paper, metal, plastic, and felt paper. Determine the deleterious content of RAS material for mixture design purposes in accordance with Tex-217-F, Part III. Do not use RAS if deleterious materials are more than 0.5% of the stockpiled RAS unless otherwise approved. Submit a sample for approval before submitting the mixture design. The Department will perform the testing for deleterious material of RAS to determine specification compliance.

2.8.

Substitute Binders. Unless otherwise shown on the plans, the Contractor may use a substitute PG binder listed in Table 5 instead of the PG binder originally specified, if the substitute PG binder and mixture made with the substitute PG binder meet the following:

- the substitute binder meets the specification requirements for the substitute binder grade in accordance with Section 300.2.10., “Performance-Graded Binders;” and
- the mixture has less than 10.0 mm of rutting on the Hamburg Wheel test (Tex-242-F) after the number of passes required for the originally specified binder. Use of substitute PG binders may only be allowed at the discretion of the Engineer if the Hamburg Wheel test results are between 10.0 mm and 12.5 mm.

Table 5
Allowable Substitute PG Binders and Maximum Recycled Binder Ratios

Originally Specified PG Binder	Allowable Substitute PG Binder	Maximum Ratio of Recycled Binder ¹ to Total Binder (%)		
		Surface	Intermediate	Base
HMA				
76-22 ²	70-22 or 64-22	20.0	20.0	20.0
	70-28 or 64-28	30.0	35.0	40.0
70-22 ²	64-22	20.0	20.0	20.0
	64-28 or 58-28	30.0	35.0	40.0
64-22 ²	58-28	30.0	35.0	40.0
76-28 ²	70-28 or 64-28	20.0	20.0	20.0
	64-34	30.0	35.0	40.0
70-28 ²	64-28 or 58-28	20.0	20.0	20.0
	64-34 or 58-34	30.0	35.0	40.0
64-28 ²	58-28	20.0	20.0	20.0
	58-34	30.0	35.0	40.0
WMA³				
76-22 ²	70-22 or 64-22	30.0	35.0	40.0
70-22 ²	64-22 or 58-28	30.0	35.0	40.0
64-22 ⁴	58-28	30.0	35.0	40.0
76-28 ²	70-28 or 64-28	30.0	35.0	40.0
70-28 ²	64-28 or 58-28	30.0	35.0	40.0
64-28 ⁴	58-28	30.0	35.0	40.0

1. Combined recycled binder from RAP and RAS.
2. Use no more than 20.0% recycled binder when using this originally specified PG binder.
3. WMA as defined in Section 341.2.6.2., “Warm Mix Asphalt (WMA).”
4. When used with WMA, this originally specified PG binder is allowed for use at the maximum recycled binder ratios shown in this table.

3. EQUIPMENT

Provide required or necessary equipment in accordance with Item 320, “Equipment for Asphalt Concrete Pavement.”

4. CONSTRUCTION

Produce, haul, place, and compact the specified paving mixture. In addition to tests required by the specification, Contractors may perform other QC tests as deemed necessary. At any time during the project, the Engineer may perform production and placement tests as deemed necessary in accordance with Item 5, “Control of the Work.” Schedule and participate in a mandatory pre-paving meeting with the Engineer on or before the first day of paving unless otherwise shown on the plans.

- 4.1. **Certification.** Personnel certified by the Department-approved hot-mix asphalt certification program must conduct all mixture designs, sampling, and testing in accordance with Table 6. Supply the Engineer with a list of certified personnel and copies of their current certificates before beginning production and when personnel changes are made. Provide a mixture design developed and signed by a Level 2 certified specialist. Provide Level 1A certified specialists at the plant during production operations. Provide Level 1B certified specialists to conduct placement tests.

Table 6
Test Methods, Test Responsibility, and Minimum Certification Levels

Test Description	Test Method	Contractor	Engineer	Level ¹
1. Aggregate and Recycled Material Testing				
Sampling	Tex-221-F	✓	✓	1A
Dry sieve	Tex-200-F, Part I	✓	✓	1A
Washed sieve	Tex-200-F, Part II	✓	✓	1A
Deleterious material	Tex-217-F, Parts I & III	✓	✓	1A
Decantation	Tex-217-F, Part II	✓	✓	1A
Los Angeles abrasion	Tex-410-A		✓	TxDOT
Magnesium sulfate soundness	Tex-411-A		✓	TxDOT
Micro-Deval abrasion	Tex-461-A		✓	2
Crushed face count	Tex-460-A	✓	✓	2
Flat and elongated particles	Tex-280-F	✓	✓	2
Linear shrinkage	Tex-107-E	✓	✓	2
Sand equivalent	Tex-203-F	✓	✓	2
Organic impurities	Tex-408-A	✓	✓	2
2. Asphalt Binder & Tack Coat Sampling				
Asphalt binder sampling	Tex-500-C, Part II	✓	✓	1A/1B
Tack coat sampling	Tex-500-C, Part III	✓	✓	1A/1B
3. Mix Design & Verification				
Design and JMF changes	Tex-204-F	✓	✓	2
Mixing	Tex-205-F	✓	✓	2
Molding (TGC)	Tex-206-F	✓	✓	1A
Molding (SGC)	Tex-241-F	✓	✓	1A
Laboratory-molded density	Tex-207-F	✓	✓	1A
VMA ² (calculation only)	Tex-204-F	✓	✓	2
Rice gravity	Tex-227-F	✓	✓	1A
Ignition oven correction factors ³	Tex-236-F	✓	✓	2
Indirect tensile strength	Tex-226-F	✓	✓	2
Hamburg Wheel test	Tex-242-F	✓	✓	2
Boil test	Tex-530-C	✓	✓	1A
4. Production Testing				
Selecting production random numbers	Tex-225-F, Part I		✓	1A
Mixture sampling	Tex-222-F	✓	✓	1A
Molding (TGC)	Tex-206-F	✓	✓	1A
Molding (SGC)	Tex-241-F	✓	✓	1A
Laboratory-molded density	Tex-207-F	✓	✓	1A
VMA ² (calculation only)	Tex-204-F	✓	✓	1A
Rice gravity	Tex-227-F	✓	✓	1A
Gradation & asphalt binder content ³	Tex-236-F	✓	✓	1A
Control charts	Tex-233-F	✓	✓	1A
Moisture content	Tex-212-F	✓	✓	1A
Hamburg Wheel test	Tex-242-F	✓	✓	2
Micro-Deval abrasion	Tex-461-A		✓	2
Boil test	Tex-530-C	✓	✓	1A
Abson recovery	Tex-211-F		✓	TxDOT
Overlay test	Tex-248-F		✓	TxDOT
Cantabro loss	Tex-245-F		✓	2
5. Placement Testing				
Selecting placement random numbers	Tex-225-F, Part II		✓	1A/1B
Trimming roadway cores	Tex-207-F	✓	✓	1A/1B
In-place air voids	Tex-207-F	✓	✓	1A/1B
Establish rolling pattern	Tex-207-F	✓		1B
Control charts	Tex-233-F	✓	✓	1A
Ride quality measurement	Tex-1001-S	✓	✓	Note ⁴
Segregation (density profile)	Tex-207-F, Part V	✓	✓	1B
Longitudinal joint density	Tex-207-F, Part VII	✓	✓	1B
Thermal profile	Tex-244-F	✓	✓	1B

1. Level 1A, 1B, and 2 are certification levels provided by the Hot Mix Asphalt Center certification program.
2. Voids in mineral aggregates.
3. Refer to Section 341.4.9.2.3., "Production Testing," for exceptions to using an ignition oven.
4. Profiler and operator are required to be certified at the Texas A&M Transportation Institute facility when Surface Test Type B is specified.

4.2.

Reporting and Responsibilities. Use Department-provided templates to record and calculate all test data, including mixture design, production and placement QC/QA, control charts, thermal profiles, segregation density profiles, and longitudinal joint density. Obtain the current version of the templates at <http://www.txdot.gov/inside-txdot/forms-publications/consultants-contractors/forms/site-manager.html> or from the Engineer. The Engineer and the Contractor will provide any available test results to the other party when requested. The maximum allowable time for the Contractor and Engineer to exchange test data is as given in Table 7 unless otherwise approved. The Engineer and the Contractor will immediately report to the other party any test result that requires suspension of production or placement, a payment adjustment less than 1.000, or that fails to meet the specification requirements. Record and electronically submit all test results and pertinent information on Department-provided templates.

Subsequent sublots placed after test results are available to the Contractor, which require suspension of operations, may be considered unauthorized work. Unauthorized work will be accepted or rejected at the discretion of the Engineer in accordance with Article 5.3., "Conformity with Plans, Specifications, and Special Provisions."

Table 7
Reporting Schedule

Description	Reported By	Reported To	To Be Reported Within
<i>Production Quality Control</i>			
Gradation ¹	Contractor	Engineer	1 working day of completion of the subplot
Asphalt binder content ¹			
Laboratory-molded density ²			
Moisture content ³			
Boil test ³			
<i>Production Quality Assurance</i>			
Gradation ³	Engineer	Contractor	1 working day of completion of the subplot
Asphalt binder content ³			
Laboratory-molded density ¹			
Hamburg Wheel test ²			
Boil test ³			
Binder tests ²			
<i>Placement Quality Control</i>			
In-place air voids ²	Contractor	Engineer	1 working day of completion of the lot
Segregation ¹			
Longitudinal joint density ¹			
Thermal profile ¹			
<i>Placement Quality Assurance</i>			
In-place air voids ¹	Engineer	Contractor	1 working day of receipt of the trimmed cores for in-place air voids ⁴
Segregation ²			
Longitudinal joint density ²			
Thermal profile ²			
Aging ratio ²			
Payment adjustment summary	Engineer	Contractor	2 working days of performing all required tests and receiving Contractor test data

1. These tests are required on every subplot.
2. Optional test. To be reported as soon as results become available.
3. To be performed at the frequency specified on the plans.
4. 2 days are allowed if cores cannot be dried to constant weight within 1 day.

The Engineer will use the Department-provided template to calculate all payment adjustment factors for the lot. Sublot samples may be discarded after the Engineer and Contractor sign off on the payment adjustment summary documentation for the lot.

Use the procedures described in Tex-233-F to plot the results of all quality control (QC) and quality assurance (QA) testing. Update the control charts as soon as test results for each subplot become available. Make the control charts readily accessible at the field laboratory. The Engineer may suspend production for failure to update control charts.

- 4.3. **Quality Control Plan (QCP).** Develop and follow the QCP in detail. Obtain approval for changes to the QCP made during the project. The Engineer may suspend operations if the Contractor fails to comply with the QCP.
- Submit a written QCP before the mandatory pre-paving meeting. Receive approval of the QCP before beginning production. Include the following items in the QCP:
- 4.3.1. **Project Personnel.** For project personnel, include:
- a list of individuals responsible for QC with authority to take corrective action;
 - current contact information for each individual listed; and
 - current copies of certification documents for individuals performing specified QC functions.
- 4.3.2. **Material Delivery and Storage.** For material delivery and storage, include:
- the sequence of material processing, delivery, and minimum quantities to assure continuous plant operations;
 - aggregate stockpiling procedures to avoid contamination and segregation;
 - frequency, type, and timing of aggregate stockpile testing to assure conformance of material requirements before mixture production; and
 - procedure for monitoring the quality and variability of asphalt binder.
- 4.3.3. **Production.** For production, include:
- loader operation procedures to avoid contamination in cold bins;
 - procedures for calibrating and controlling cold feeds;
 - procedures to eliminate debris or oversized material;
 - procedures for adding and verifying rates of each applicable mixture component (e.g., aggregate, asphalt binder, RAP, RAS, lime, liquid antistriper, WMA);
 - procedures for reporting job control test results; and
 - procedures to avoid segregation and drain-down in the silo.
- 4.3.4. **Loading and Transporting.** For loading and transporting, include:
- type and application method for release agents; and
 - truck loading procedures to avoid segregation.
- 4.3.5. **Placement and Compaction.** For placement and compaction, include:
- proposed agenda for mandatory pre-paving meeting, including date and location;
 - proposed paving plan (e.g., paving widths, joint offsets, and lift thicknesses);
 - type and application method for release agents in the paver and on rollers, shovels, lutes, and other utensils;
 - procedures for the transfer of mixture into the paver, while avoiding segregation and preventing material spillage;
 - process to balance production, delivery, paving, and compaction to achieve continuous placement operations and good ride quality;
 - paver operations (e.g., operation of wings, height of mixture in auger chamber) to avoid physical and thermal segregation and other surface irregularities; and
 - procedures to construct quality longitudinal and transverse joints.
- 4.4. **Mixture Design.**
- 4.4.1. **Design Requirements.** The Contractor may design the mixture using a Texas Gyratory Compactor (TGC) or a Superpave Gyratory Compactor (SGC) unless otherwise shown on the plans. Use the dense-graded

design procedure provided in Tex-204-F. Design the mixture to meet the requirements listed in Tables 1, 2, 3, 4, 5, 8, 9, and 10.

- 4.4.1.1. **Target Laboratory-Molded Density When The TGC Is Used.** Design the mixture at a 96.5% target laboratory-molded density. Increase the target laboratory-molded density to 97.0% or 97.5% at the Contractor's discretion or when shown on the plans or specification.
- 4.4.1.2. **Design Number of Gyration (Ndesign) When The SGC Is Used.** Design the mixture at 50 gyrations (Ndesign). Use a target laboratory-molded density of 96.0% to design the mixture; however, adjustments can be made to the Ndesign value as noted in Table 9. The Ndesign level may be reduced to no less than 35 gyrations at the Contractor's discretion.

Use an approved laboratory from the Department's MPL to perform the Hamburg Wheel test, and provide results with the mixture design, or provide the laboratory mixture and request that the Department perform the Hamburg Wheel test. The Engineer will be allowed 10 working days to provide the Contractor with Hamburg Wheel test results on the laboratory mixture design.

The Engineer will provide the mixture design when shown on the plans. The Contractor may submit a new mixture design at any time during the project. The Engineer will verify and approve all mixture designs (JMF1) before the Contractor can begin production.

Provide the Engineer with a mixture design report using the Department-provided template. Include the following items in the report:

- the combined aggregate gradation, source, specific gravity, and percent of each material used;
- asphalt binder content and aggregate gradation of RAP and RAS stockpiles;
- the target laboratory-molded density (or Ndesign level when using the SGC);
- results of all applicable tests;
- the mixing and molding temperatures;
- the signature of the Level 2 person or persons that performed the design;
- the date the mixture design was performed; and
- a unique identification number for the mixture design.

Table 8
Master Gradation Limits (% Passing by Weight or Volume) and VMA Requirements

Sieve Size	A Coarse Base	B Fine Base	C Coarse Surface	D Fine Surface	F Fine Mixture
2"	100.0 ¹	–	–	–	–
1-1/2"	98.0–100.0	100.0 ¹	–	–	–
1"	78.0–94.0	98.0–100.0	100.0 ¹	–	–
3/4"	64.0–85.0	84.0–98.0	95.0–100.0	100.0 ¹	–
1/2"	50.0–70.0	–	–	98.0–100.0	100.0 ¹
3/8"	–	60.0–80.0	70.0–85.0	85.0–100.0	98.0–100.0
#4	30.0–50.0	40.0–60.0	43.0–63.0	50.0–70.0	70.0–90.0
#8	22.0–36.0	29.0–43.0	32.0–44.0	35.0–46.0	38.0–48.0
#30	8.0–23.0	13.0–28.0	14.0–28.0	15.0–29.0	12.0–27.0
#50	3.0–19.0	6.0–20.0	7.0–21.0	7.0–20.0	6.0–19.0
#200	2.0–7.0	2.0–7.0	2.0–7.0	2.0–7.0	2.0–7.0
Design VMA, % Minimum					
–	12.0	13.0	14.0	15.0	16.0
Production (Plant-Produced) VMA, % Minimum					
–	11.5	12.5	13.5	14.5	15.5

1. Defined as maximum sieve size. No tolerance allowed.

Table 9
Laboratory Mixture Design Properties

Mixture Property	Test Method	Requirement
Target laboratory-molded density, % (TGC)	Tex-207-F	96.5 ¹
Design gyrations (Ndesign for SGC)	Tex-241-F	50 ²
Indirect tensile strength (dry), psi	Tex-226-F	85–200 ³
Boil test ⁴	Tex-530-C	–

- Increase to 97.0% or 97.5% at the Contractor's discretion or when shown on the plans or specification.
- Adjust within a range of 35–100 gyrations when shown on the plans or specification or when mutually agreed between the Engineer and Contractor.
- The Engineer may allow the IDT strength to exceed 200 psi if the corresponding Hamburg Wheel rut depth is greater than 3.0 mm and less than 12.5 mm.
- Used to establish baseline for comparison to production results. May be waived when approved.

Table 10
Hamburg Wheel Test Requirements

High-Temperature Binder Grade	Test Method	Minimum # of Passes @ 12.5 mm ¹ Rut Depth, Tested @ 50°C
PG 64 or lower	Tex-242-F	10,000 ²
PG 70		15,000 ³
PG 76 or higher		20,000

- When the rut depth at the required minimum number of passes is less than 3 mm, the Engineer may require the Contractor to increase the target laboratory-molded density (TGC) by 0.5% to no more than 97.5% or lower the Ndesign level (SGC) to no less than 35 gyrations.
- May be decreased to no less than 5,000 passes when shown on the plans.
- May be decreased to no less than 10,000 passes when shown on the plans.

4.4.2. **Job-Mix Formula Approval.** The job-mix formula (JMF) is the combined aggregate gradation, target laboratory-molded density (or Ndesign level), and target asphalt percentage used to establish target values for hot-mix production. JMF1 is the original laboratory mixture design used to produce the trial batch. When WMA is used, JMF1 may be designed and submitted to the Engineer without including the WMA additive. When WMA is used, document the additive or process used and recommended rate on the JMF1 submittal. The Engineer and the Contractor will verify JMF1 based on plant-produced mixture from the trial batch unless otherwise approved. The Engineer may accept an existing mixture design previously used on a Department project and may waive the trial batch to verify JMF1. The Department may require the Contractor to reimburse the Department for verification tests if more than 2 trial batches per design are required.

4.4.2.1. **Contractor's Responsibilities.**

4.4.2.1.1. **Providing Gyrotory Compactor.** Use a TGC calibrated in accordance with Tex-914-K when electing or required to design the mixture in accordance with Tex-204-F, Part I, for molding production samples. Furnish an SGC calibrated in accordance with Tex-241-F when electing or required to design the mixture in accordance with Tex-204-F, Part IV, for molding production samples. Locate the SGC, if used, at the Engineer's field laboratory and make the SGC available to the Engineer for use in molding production samples.

4.4.2.1.2. **Gyrotory Compactor Correlation Factors.** Use Tex-206-F, Part II, to perform a gyrotory compactor correlation when the Engineer uses a different gyrotory compactor. Apply the correlation factor to all subsequent production test results.

4.4.2.1.3. **Submitting JMF1.** Furnish a mix design report (JMF1) with representative samples of all component materials and request approval to produce the trial batch. Provide approximately 10,000 g of the design mixture if opting to have the Department perform the Hamburg Wheel test on the laboratory mixture, and request that the Department perform the test.

4.4.2.1.4. **Supplying Aggregates.** Provide approximately 40 lb. of each aggregate stockpile unless otherwise directed.

- 4.4.2.1.5. **Supplying Asphalt.** Provide at least 1 gal. of the asphalt material and sufficient quantities of any additives proposed for use.
- 4.4.2.1.6. **Ignition Oven Correction Factors.** Determine the aggregate and asphalt correction factors from the ignition oven in accordance with Tex-236-F. Provide the Engineer with split samples of the mixtures before the trial batch production, including all additives (except water), and blank samples used to determine the correction factors for the ignition oven used for QA testing during production. Correction factors established from a previously approved mixture design may be used for the current mixture design if the mixture design and ignition oven are the same as previously used, unless otherwise directed.
- 4.4.2.1.7. **Boil Test.** Perform the test and retain the tested sample from Tex-530-C until completion of the project or as directed. Use this sample for comparison purposes during production. The Engineer may waive the requirement for the boil test.
- 4.4.2.1.8. **Trial Batch Production.** Provide a plant-produced trial batch upon receiving conditional approval of JMF1 and authorization to produce a trial batch, including the WMA additive or process if applicable, for verification testing of JMF1 and development of JMF2. Produce a trial batch mixture that meets the requirements in Table 4, Table 5, and Table 11. The Engineer may accept test results from recent production of the same mixture instead of a new trial batch.
- 4.4.2.1.9. **Trial Batch Production Equipment.** Use only equipment and materials proposed for use on the project to produce the trial batch.
- 4.4.2.1.10. **Trial Batch Quantity.** Produce enough quantity of the trial batch to ensure that the mixture meets the specification requirements.
- 4.4.2.1.11. **Number of Trial Batches.** Produce trial batches as necessary to obtain a mixture that meets the specification requirements.
- 4.4.2.1.12. **Trial Batch Sampling.** Obtain a representative sample of the trial batch and split it into 3 equal portions in accordance with Tex-222-F. Label these portions as "Contractor," "Engineer," and "Referee." Deliver samples to the appropriate laboratory as directed.
- 4.4.2.1.13. **Trial Batch Testing.** Test the trial batch to ensure the mixture produced using the proposed JMF1 meets the mixture requirements in Table 11. Ensure the trial batch mixture is also in compliance with the Hamburg Wheel requirement in Table 10. Use a Department-approved laboratory to perform the Hamburg Wheel test on the trial batch mixture or request that the Department perform the Hamburg Wheel test. The Engineer will be allowed 10 working days to provide the Contractor with Hamburg Wheel test results on the trial batch. Provide the Engineer with a copy of the trial batch test results.
- 4.4.2.1.14. **Development of JMF2.** Evaluate the trial batch test results after the Engineer grants full approval of JMF1 based on results from the trial batch, determine the optimum mixture proportions, and submit as JMF2. Adjust the asphalt binder content or gradation to achieve the specified target laboratory-molded density. The asphalt binder content established for JMF2 is not required to be within any tolerance of the optimum asphalt binder content established for JMF1; however, mixture produced using JMF2 must meet the voids in mineral aggregates (VMA) requirements for production shown in Table 8. If the optimum asphalt binder content for JMF2 is more than 0.5% lower than the optimum asphalt binder content for JMF1, the Engineer may perform or require the Contractor to perform Tex-226-F on Lot 1 production to confirm the indirect tensile strength does not exceed 200 psi. Verify that JMF2 meets the mixture requirements in Table 5.
- 4.4.2.1.15. **Mixture Production.** Use JMF2 to produce Lot 1 as described in Section 341.4.9.3.1.1., "Lot 1 Placement," after receiving approval for JMF2 and a passing result from the Department's or a Department-approved laboratory's Hamburg Wheel test on the trial batch. If desired, proceed to Lot 1 production, once JMF2 is approved, at the Contractor's risk without receiving the results from the Department's Hamburg Wheel test on the trial batch.

Notify the Engineer if electing to proceed without Hamburg Wheel test results from the trial batch. Note that the Engineer may require up to the entire subplot of any mixture failing the Hamburg Wheel test to be removed and replaced at the Contractor's expense.

4.4.2.1.16. **Development of JMF3.** Evaluate the test results from Lot 1, determine the optimum mixture proportions, and submit as JMF3 for use in Lot 2.

4.4.2.1.17. **JMF Adjustments.** If JMF adjustments are necessary to achieve the specified requirements, make the adjustments before beginning a new lot. The adjusted JMF must:

- be provided to the Engineer in writing before the start of a new lot;
- be numbered in sequence to the previous JMF;
- meet the mixture requirements in Table 4 and Table 5;
- meet the master gradation limits shown in Table 8; and
- be within the operational tolerances of JMF2 listed in Table 11.

4.4.2.1.18. **Requesting Referee Testing.** Use referee testing, if needed, in accordance with Section 341.4.9.1., "Referee Testing," to resolve testing differences with the Engineer.

Table 11
Operational Tolerances

Description	Test Method	Allowable Difference Between Trial Batch and JMF1 Target	Allowable Difference from Current JMF Target	Allowable Difference between Contractor and Engineer ¹
Individual % retained for #8 sieve and larger	Tex-200-F or Tex-236-F	Must be Within Master Grading Limits in Table 8	±5.0 ^{2,3}	±5.0
Individual % retained for sieves smaller than #8 and larger than #200			±3.0 ^{2,3}	±3.0
% passing the #200 sieve			±2.0 ^{2,3}	±1.6
Asphalt binder content, %	Tex-236-F	±0.5	±0.3 ³	±0.3
Laboratory-molded density, %	Tex-207-F	±1.0	±1.0	±1.0
In-place air voids, %		N/A	N/A	±1.0
Laboratory-molded bulk specific gravity		N/A	N/A	±0.020
VMA, %, min	Tex-204-F	Note ⁴	Note ⁴	N/A
Theoretical maximum specific (Rice) gravity	Tex-227-F	N/A	N/A	±0.020

1. Contractor may request referee testing only when values exceed these tolerances.
2. When within these tolerances, mixture production gradations may fall outside the master grading limits; however, the % passing the #200 will be considered out of tolerance when outside the master grading limits.
3. Only applies to mixture produced for Lot 1 and higher.
4. Test and verify that Table 8 requirements are met.

4.4.2.2. **Engineer's Responsibilities.**

4.4.2.2.1. **Gyratory Compactor.** For mixtures designed in accordance with Tex-204-F, Part I, the Engineer will use a Department TGC, calibrated in accordance with Tex-914-K, to mold samples for trial batch and production testing. The Engineer will make the Department TGC and the Department field laboratory available to the Contractor for molding verification samples, if requested by the Contractor.

For mixtures designed in accordance with Tex-204-F, Part IV, the Engineer will use a Department SGC, calibrated in accordance with Tex-241-F, to mold samples for laboratory mixture design verification. For molding trial batch and production specimens, the Engineer will use the Contractor-provided SGC at the field laboratory or provide and use a Department SGC at an alternate location. The Engineer will make the Contractor-provided SGC in the Department field laboratory available to the Contractor for molding verification samples.

4.4.2.2.2. **Conditional Approval of JMF1 and Authorizing Trial Batch.** The Engineer will review and verify conformance of the following information within 2 working days of receipt:

- the Contractor's mix design report (JMF1);
- the Contractor-provided Hamburg Wheel test results;

- all required materials including aggregates, asphalt, additives, and recycled materials; and
- the mixture specifications.

The Engineer will grant the Contractor conditional approval of JMF1 if the information provided on the paper copy of JMF1 indicates that the Contractor's mixture design meets the specifications. When the Contractor does not provide Hamburg Wheel test results with laboratory mixture design, 10 working days are allowed for conditional approval of JMF1. The Engineer will base full approval of JMF1 on the test results on mixture from the trial batch.

Unless waived, the Engineer will determine the Micro-Deval abrasion loss in accordance with Section 341.2.1.1.2., "Micro-Deval Abrasion." If the Engineer's test results are pending after 2 working days, conditional approval of JMF1 will still be granted within 2 working days of receiving JMF1. When the Engineer's test results become available, they will be used for specification compliance.

After conditionally approving JMF1, including either Contractor- or Department-supplied Hamburg Wheel test results, the Contractor is authorized to produce a trial batch.

4.4.2.2.3. **Hamburg Wheel Testing of JMF1.** If the Contractor requests the option to have the Department perform the Hamburg Wheel test on the laboratory mixture, the Engineer will mold samples in accordance with Tex-242-F to verify compliance with the Hamburg Wheel test requirement in Table 10.

4.4.2.2.4. **Ignition Oven Correction Factors.** The Engineer will use the split samples provided by the Contractor to determine the aggregate and asphalt correction factors for the ignition oven used for QA testing during production in accordance with Tex-236-F.

4.4.2.2.5. **Testing the Trial Batch.** Within 1 full working day, the Engineer will sample and test the trial batch to ensure that the mixture meets the requirements in Table 11. If the Contractor requests the option to have the Department perform the Hamburg Wheel test on the trial batch mixture, the Engineer will mold samples in accordance with Tex-242-F to verify compliance with the Hamburg Wheel test requirement in Table 10.

The Engineer will have the option to perform the following tests on the trial batch:

- Tex-226-F, to verify that the indirect tensile strength meets the requirement shown in Table 9; and
- Tex-530-C, to retain and use for comparison purposes during production.

4.4.2.2.6. **Full Approval of JMF1.** The Engineer will grant full approval of JMF1 and authorize the Contractor to proceed with developing JMF2 if the Engineer's results for the trial batch meet the requirements in Table 11. The Engineer will notify the Contractor that an additional trial batch is required if the trial batch does not meet these requirements.

4.4.2.2.7. **Approval of JMF2.** The Engineer will approve JMF2 within one working day if the mixture meets the requirements in Table 5 and the gradation meets the master grading limits shown in Table 8. The asphalt binder content established for JMF2 is not required to be within any tolerance of the optimum asphalt binder content established for JMF1; however, mixture produced using JMF2 must meet the VMA requirements shown in Table 8. If the optimum asphalt binder content for JMF2 is more than 0.5% lower than the optimum asphalt binder content for JMF1, the Engineer may perform or require the Contractor to perform Tex-226-F on Lot 1 production to confirm the indirect tensile strength does not exceed 200 psi.

4.4.2.2.8. **Approval of Lot 1 Production.** The Engineer will authorize the Contractor to proceed with Lot 1 production (using JMF2) as soon as a passing result is achieved from the Department's or a Department-approved laboratory's Hamburg Wheel test on the trial batch. The Contractor may proceed at its own risk with Lot 1 production without the results from the Hamburg Wheel test on the trial batch.

If the Department's or Department-approved laboratory's sample from the trial batch fails the Hamburg Wheel test, the Engineer will suspend production until further Hamburg Wheel tests meet the specified values. The Engineer may require up to the entire subplot of any mixture failing the Hamburg Wheel test be removed and replaced at the Contractor's expense.

- 4.4.2.2.9. **Approval of JMF3 and Subsequent JMF Changes.** JMF3 and subsequent JMF changes are approved if they meet the mixture requirements shown in Table 4, Table 5, and the master grading limits shown in Table 8, and are within the operational tolerances of JMF2 shown in Table 11.
- 4.5. **Production Operations.** Perform a new trial batch when the plant or plant location is changed. Take corrective action and receive approval to proceed after any production suspension for noncompliance to the specification. Submit a new mix design and perform a new trial batch when the asphalt binder content of:
- any RAP stockpile used in the mix is more than 0.5% higher than the value shown on the mixture design report; or
 - RAS stockpile used in the mix is more than 2.0% higher than the value shown on the mixture design report.
- 4.5.1. **Storage and Heating of Materials.** Do not heat the asphalt binder above the temperatures specified in Item 300, "Asphalts, Oils, and Emulsions," or outside the manufacturer's recommended values. Provide the Engineer with daily records of asphalt binder and hot-mix asphalt discharge temperatures (in legible and discernible increments) in accordance with Item 320, "Equipment for Asphalt Concrete Pavement," unless otherwise directed. Do not store mixture for a period long enough to affect the quality of the mixture, nor in any case longer than 12 hr. unless otherwise approved.
- 4.5.2. **Mixing and Discharge of Materials.** Notify the Engineer of the target discharge temperature and produce the mixture within 25°F of the target. Monitor the temperature of the material in the truck before shipping to ensure that it does not exceed 350°F (or 275°F for WMA) and is not lower than 215°F. The Department will not pay for or allow placement of any mixture produced above 350°F.
- Produce WMA within the target discharge temperature range of 215°F and 275°F when WMA is required. Take corrective action any time the discharge temperature of the WMA exceeds the target discharge range. The Engineer may suspend production operations if the Contractor's corrective action is not successful at controlling the production temperature within the target discharge range. Note that when WMA is produced, it may be necessary to adjust burners to ensure complete combustion such that no burner fuel residue remains in the mixture.
- Control the mixing time and temperature so that substantially all moisture is removed from the mixture before discharging from the plant. Determine the moisture content, if requested, by oven-drying in accordance with Tex-212-F, Part II, and verify that the mixture contains no more than 0.2% of moisture by weight. Obtain the sample immediately after discharging the mixture into the truck, and perform the test promptly.
- 4.6. **Hauling Operations.** Clean all truck beds before use to ensure that mixture is not contaminated. Use a release agent shown on the Department's MPL to coat the inside bed of the truck when necessary.
- Use equipment for hauling as defined in Section 341.4.7.3.3., "Hauling Equipment." Use other hauling equipment only when allowed.
- 4.7. **Placement Operations.** Collect haul tickets from each load of mixture delivered to the project and provide the Department's copy to the Engineer approximately every hour, or as directed. Use a hand-held thermal camera or infrared thermometer, when a thermal imaging system is not used, to measure and record the internal temperature of the mixture as discharged from the truck or Material Transfer Device (MTD) before or as the mix enters the paver and an approximate station number or GPS coordinates on each ticket. Calculate the daily yield and cumulative yield for the specified lift and provide to the Engineer at the end of paving operations for each day unless otherwise directed. The Engineer may suspend production if the Contractor fails to produce and provide haul tickets and yield calculations by the end of paving operations for each day.
- Prepare the surface by removing raised pavement markers and objectionable material such as moisture, dirt, sand, leaves, and other loose impediments from the surface before placing mixture. Remove vegetation from pavement edges. Place the mixture to meet the typical section requirements and produce a smooth, finished surface with a uniform appearance and texture. Offset longitudinal joints of successive courses of hot-mix by at least 6 in. Place mixture so that longitudinal joints on the surface course coincide with lane lines, or as

directed. Ensure that all finished surfaces will drain properly. Place the mixture at the rate or thickness shown on the plans. The Engineer will use the guidelines in Table 12 to determine the compacted lift thickness of each layer when multiple lifts are required. The thickness determined is based on the rate of 110 lb./sq. yd. for each inch of pavement unless otherwise shown on the plans.

Table 12
Compacted Lift Thickness and Required Core Height

Mixture Type	Compacted Lift Thickness Guidelines		Minimum Untrimmed Core Height (in.) Eligible for Testing
	Minimum (in.)	Maximum (in.)	
A	3.00	6.00	2.00
B	2.50	5.00	1.75
C	2.00	4.00	1.50
D	1.50	3.00	1.25
F	1.25	2.50	1.25

4.7.1. Weather Conditions.

4.7.1.1. **When Using a Thermal Imaging System.** The Contractor may pave any time the roadway is dry and the roadway surface temperature is at least 32°F; however, the Engineer may restrict the Contractor from paving surface mixtures if the ambient temperature is likely to drop below 32°F within 12 hr. of paving. Provide output data from the thermal imaging system to demonstrate to the Engineer that no recurring severe thermal segregation exists in accordance with Section 341.4.7.3.1.2., “Thermal Imaging System.”

4.7.1.2. **When Not Using a Thermal Imaging System.** Place mixture when the roadway surface temperature is at or above the temperatures listed in Table 13 unless otherwise approved or as shown on the plans. Measure the roadway surface temperature with a hand-held thermal camera or infrared thermometer. The Engineer may allow mixture placement to begin before the roadway surface reaches the required temperature if conditions are such that the roadway surface will reach the required temperature within 2 hr. of beginning placement operations. Place mixtures only when weather conditions and moisture conditions of the roadway surface are suitable as determined by the Engineer. The Engineer may restrict the Contractor from paving if the ambient temperature is likely to drop below 32°F within 12 hr. of paving.

Table 13
Minimum Pavement Surface Temperatures

Originally Specified High Temperature Binder Grade	Minimum Pavement Surface Temperatures (°F)	
	Subsurface Layers or Night Paving Operations	Surface Layers Placed in Daylight Operations
PG 64 or lower	45	50
PG 70	55 ¹	60 ¹
PG 76 or higher	60 ¹	60 ¹

1. Contractors may pave at temperatures 10°F lower than these values when utilizing a paving process including WMA or equipment that eliminates thermal segregation. In such cases, use a hand-held thermal camera operated in accordance with Tex-244-F to demonstrate to the satisfaction of the Engineer that the uncompacted mat has no more than 10°F of thermal segregation.

4.7.2. **Tack Coat.** Clean the surface before placing the tack coat. The Engineer will set the rate between 0.04 and 0.10 gal. of residual asphalt per square yard of surface area. Apply a uniform tack coat at the specified rate unless otherwise directed. Apply the tack coat in a uniform manner to avoid streaks and other irregular patterns. Apply a thin, uniform tack coat to all contact surfaces of curbs, structures, and all joints. Allow adequate time for emulsion to break completely before placing any material. Prevent splattering of tack coat when placed adjacent to curb, gutter, and structures. Roll the tack coat with a pneumatic-tire roller to remove streaks and other irregular patterns when directed.

4.7.3. Lay-Down Operations.

4.7.3.1. **Thermal Profile.** Use a hand-held thermal camera or a thermal imaging system to obtain a continuous thermal profile in accordance with Tex-244-F. Thermal profiles are not applicable in areas described in Section 341.4.9.3.1.4., “Miscellaneous Areas.”

- 4.7.3.1.1. **Thermal Segregation.**
- 4.7.3.1.1.1. **Moderate.** Any areas that have a temperature differential greater than 25°F, but not exceeding 50°F, are deemed as having moderate thermal segregation.
- 4.7.3.1.1.2. **Severe.** Any areas that have a temperature differential greater than 50°F are deemed as having severe thermal segregation.
- 4.7.3.1.2. **Thermal Imaging System.** Review the output results when a thermal imaging system is used, and provide the automated report described in Tex-244-F to the Engineer daily unless otherwise directed. Modify the paving process as necessary to eliminate any recurring (moderate or severe) thermal segregation identified by the thermal imaging system. The Engineer may suspend paving operations if the Contractor cannot successfully modify the paving process to eliminate recurring severe thermal segregation. Density profiles are not required and not applicable when using a thermal imaging system. Provide the Engineer with electronic copies of all daily data files that can be used with the thermal imaging system software to generate temperature profile plots upon completion of the project or as requested by the Engineer.
- 4.7.3.1.3. **Thermal Camera.** Take immediate corrective action to eliminate recurring moderate thermal segregation when a hand-held thermal camera is used. Evaluate areas with moderate thermal segregation by performing density profiles in accordance with Section 341.4.9.3.3.2., "Segregation (Density Profile)." Provide the Engineer with the thermal profile of every subplot within one working day of the completion of each lot. Report the results of each thermal profile in accordance with Section 341.4.2., "Reporting and Responsibilities." The Engineer will use a hand-held thermal camera to obtain a thermal profile at least once per project. No production or placement payment adjustments greater than 1.000 will be paid for any subplot that contains severe thermal segregation. Suspend operations and take immediate corrective action to eliminate severe thermal segregation unless otherwise directed. Resume operations when the Engineer determines that subsequent production will meet the requirements of this Section. Evaluate areas with severe thermal segregation by performing density profiles in accordance with Section 341.4.9.3.3.2., "Segregation (Density Profile)." Remove and replace the material in any areas that have both severe thermal segregation and a failing result for Segregation (Density Profile) unless otherwise directed. The subplot in question may receive a production and placement payment adjustment greater than 1.000, if applicable, when the defective material is successfully removed and replaced.
- 4.7.3.2. **Windrow Operations.** Operate windrow pickup equipment so that when hot-mix is placed in windrows, substantially all the mixture deposited on the roadbed is picked up and loaded into the paver.
- 4.7.3.3. **Hauling Equipment.** Use belly dumps, live bottom, or end dump trucks to haul and transfer mixture; however, with exception of paving miscellaneous areas, end dump trucks are only allowed when used in conjunction with an MTD with remixing capability or when a thermal imaging system is used unless otherwise allowed.
- 4.7.3.4. **Screed Heaters.** Turn off screed heaters to prevent overheating of the mat if the paver stops for more than 5 min. The Engineer may evaluate the suspect area in accordance with Section 341.4.9.3.3.4., "Recovered Asphalt Dynamic Shear Rheometer (DSR)," if the screed heater remains on for more than 5 min. while the paver is stopped.
- 4.8. **Compaction.** Compact the pavement uniformly to contain between 3.8% and 8.5% in-place air voids. Take immediate corrective action to bring the operation within 3.8% and 8.5% when the in-place air voids exceed the range of these tolerances. The Engineer will allow paving to resume when the proposed corrective action is likely to yield between 3.8% and 8.5% in-place air voids.

Obtain cores in areas placed under Exempt Production, as directed, at locations determined by the Engineer. The Engineer may test these cores and suspend operations or require removal and replacement if the in-place air voids are less than 2.7% or more than 9.9%. Areas defined in Section 341.4.9.3.1.4., "Miscellaneous Areas," are not subject to in-place air void determination.

Furnish the type, size, and number of rollers required for compaction as approved. Use a pneumatic-tire roller to seal the surface unless excessive pickup of fines occurs. Use additional rollers as required to remove any roller marks. Use only water or an approved release agent on rollers, tamps, and other compaction equipment unless otherwise directed.

Use the control strip method shown in Tex-207-F, Part IV, on the first day of production to establish the rolling pattern that will produce the desired in-place air voids unless otherwise directed.

Use tamps to thoroughly compact the edges of the pavement along curbs, headers, and similar structures and in locations that will not allow thorough compaction with rollers. The Engineer may require rolling with a trench roller on widened areas, in trenches, and in other limited areas.

Complete all compaction operations before the pavement temperature drops below 160°F unless otherwise allowed. The Engineer may allow compaction with a light finish roller operated in static mode for pavement temperatures below 160°F.

Allow the compacted pavement to cool to 160°F or lower before opening to traffic unless otherwise directed. Sprinkle the finished mat with water or limewater, when directed, to expedite opening the roadway to traffic.

- 4.9. **Acceptance Plan.** Payment adjustments for the material will be in accordance with Article 341.6., "Payment."

Sample and test the hot-mix on a lot and subplot basis. Suspend production until test results or other information indicates to the satisfaction of the Engineer that the next material produced or placed will result in payment factors of at least 1.000, if the production payment factor given in Section 341.6.1., "Production Payment Adjustment Factors," for 2 consecutive lots or the placement pay factor given in Section 341.6.2., "Placement Payment Adjustment Factors," for 2 consecutive lots is below 1.000.

- 4.9.1. **Referee Testing.** The Construction Division is the referee laboratory. The Contractor may request referee testing if a "remove and replace" condition is determined based on the Engineer's test results, or if the differences between Contractor and Engineer test results exceed the maximum allowable difference shown in Table 11 and the differences cannot be resolved. The Contractor may also request referee testing if the Engineer's test results require suspension of production and the Contractor's test results are within specification limits. Make the request within 5 working days after receiving test results and cores from the Engineer. Referee tests will be performed only on the subplot in question and only for the particular tests in question. Allow 10 working days from the time the referee laboratory receives the samples for test results to be reported. The Department may require the Contractor to reimburse the Department for referee tests if more than 3 referee tests per project are required and the Engineer's test results are closer to the referee test results than the Contractor's test results.

The Construction Division will determine the laboratory-molded density based on the molded specific gravity and the maximum theoretical specific gravity of the referee sample. The in-place air voids will be determined based on the bulk specific gravity of the cores, as determined by the referee laboratory and the Engineer's average maximum theoretical specific gravity for the lot. With the exception of "remove and replace" conditions, referee test results are final and will establish payment adjustment factors for the subplot in question. The Contractor may decline referee testing and accept the Engineer's test results when the placement payment adjustment factor for any subplot results in a "remove and replace" condition. Placement sublots subject to be removed and replaced will be further evaluated in accordance with Section 341.6.2.2., "Placement Sublots Subject to Removal and Replacement."

- 4.9.2. **Production Acceptance.**

- 4.9.2.1. **Production Lot.** A production lot consists of 4 equal sublots. The default quantity for Lot 1 is 1,000 tons; however, when requested by the Contractor, the Engineer may increase the quantity for Lot 1 to no more than 4,000 tons. The Engineer will select subsequent lot sizes based on the anticipated daily production such that approximately 3 to 4 sublots are produced each day. The lot size will be between 1,000 tons and 4,000 tons. The Engineer may change the lot size before the Contractor begins any lot.

If the optimum asphalt binder content for JMF2 is more than 0.5% lower than the optimum asphalt binder content for JMF1, the Engineer may perform or require the Contractor to perform Tex-226-F on Lot 1 to confirm the indirect tensile strength does not exceed 200 psi. Take corrective action to bring the mixture within specification compliance if the indirect tensile strength exceeds 200 psi unless otherwise directed.

- 4.9.2.1.1. **Incomplete Production Lots.** If a lot is begun but cannot be completed, such as on the last day of production or in other circumstances deemed appropriate, the Engineer may close the lot. Adjust the payment for the incomplete lot in accordance with Section 341.6.1., "Production Payment Adjustment Factors." Close all lots within 5 working days unless otherwise allowed.
- 4.9.2.2. **Production Sampling.**
- 4.9.2.2.1. **Mixture Sampling.** Obtain hot-mix samples from trucks at the plant in accordance with Tex-222-F. The sampler will split each sample into 3 equal portions in accordance with Tex-200-F and label these portions as "Contractor," "Engineer," and "Referee." The Engineer will perform or witness the sample splitting and take immediate possession of the samples labeled "Engineer" and "Referee." The Engineer will maintain the custody of the samples labeled "Engineer" and "Referee" until the Department's testing is completed.
- 4.9.2.2.1.1. **Random Sample.** At the beginning of the project, the Engineer will select random numbers for all production sublots. Determine sample locations in accordance with Tex-225-F. Take one sample for each subplot at the randomly selected location. The Engineer will perform or witness the sampling of production sublots.
- 4.9.2.2.1.2. **Blind Sample.** For one subplot per lot, the Engineer will obtain and test a "blind" sample instead of the random sample collected by the Contractor. Test either the "blind" or the random sample; however, referee testing (if applicable) will be based on a comparison of results from the "blind" sample. The location of the Engineer's "blind" sample will not be disclosed to the Contractor. The Engineer's "blind" sample may be randomly selected in accordance with Tex-225-F for any subplot or selected at the discretion of the Engineer. The Engineer will use the Contractor's split sample for sublots not sampled by the Engineer.
- 4.9.2.2.2. **Informational Cantabro and Overlay Testing.** When requested or shown on the plans, select one random subplot from Lot 2 or higher for Cantabro and Overlay testing during the first week of production. Obtain and provide the Engineer with approximately 90 lb. (40 kg) of mixture in sealed containers, boxes, or bags labeled with the Control-Section-Job (CSJ), mixture type, lot, and subplot number. The Engineer will ship the mixture to the Construction Division for Cantabro and Overlay testing. Results from these tests will not be used for specification compliance.
- 4.9.2.2.3. **Asphalt Binder Sampling.** Obtain a 1-qt. sample of the asphalt binder for each lot of mixture produced. Obtain the sample at approximately the same time the mixture random sample is obtained. Sample from a port located immediately upstream from the mixing drum or pug mill in accordance with Tex-500-C, Part II. Label the can with the corresponding lot and subplot numbers and deliver the sample to the Engineer. The Engineer may also obtain independent samples. If obtaining an independent asphalt binder sample, the Engineer will split a sample of the asphalt binder with the Contractor. The Engineer will test at least one asphalt binder sample per project to verify compliance with Item 300, "Asphalts, Oils, and Emulsions."
- 4.9.2.3. **Production Testing.** The Contractor and Engineer must perform production tests in accordance with Table 14. The Contractor has the option to verify the Engineer's test results on split samples provided by the Engineer. Determine compliance with operational tolerances listed in Table 11 for all sublots.

Take immediate corrective action if the Engineer's laboratory-molded density on any subplot is less than 95.0% or greater than 98.0% to bring the mixture within these tolerances. The Engineer may suspend operations if the Contractor's corrective actions do not produce acceptable results. The Engineer will allow production to resume when the proposed corrective action is likely to yield acceptable results.

The Engineer may allow alternate methods for determining the asphalt binder content and aggregate gradation if the aggregate mineralogy is such that Tex-236-F does not yield reliable results. Provide evidence that results from Tex-236-F are not reliable before requesting permission to use an alternate method unless otherwise directed. Use the applicable test procedure as directed if an alternate test method is allowed.

Table 14
Production and Placement Testing Frequency

Description	Test Method	Minimum Contractor Testing Frequency	Minimum Engineer Testing Frequency
Individual % retained for #8 sieve and larger	Tex-200-F or Tex-236-F	1 per subplot	1 per 12 sublots ¹
Individual % retained for sieves smaller than #8 and larger than #200			
% passing the #200 sieve			
Laboratory-molded density	Tex-207-F	N/A	1 per subplot ¹
Laboratory-molded bulk specific gravity			
In-place air voids			
VMA	Tex-204-F	1 per subplot	1 per project
Segregation (density profile) ²	Tex-207-F, Part V		
Longitudinal joint density	Tex-207-F, Part VII	When directed	1 per subplot ¹
Moisture content	Tex-212-F, Part II	N/A	
Theoretical maximum specific (Rice) gravity	Tex-227-F	1 per subplot	1 per lot ¹
Asphalt binder content	Tex-236-F	N/A	1 per project
Hamburg Wheel test	Tex-242-F	N/A	
Recycled Asphalt Shingles (RAS) ³	Tex-217-F, Part III	N/A	
Thermal profile ²	Tex-244-F	1 per subplot	
Asphalt binder sampling and testing	Tex-500-C	1 per lot (sample only)	
Tack coat sampling and testing	Tex-500-C, Part III	N/A	
Boil test ⁴	Tex-530-C	1 per lot	
Cantabro loss ⁵	Tex-245-F	1 per project (sample only)	
Overlay test ⁵	Tex-248-F		

1. For production defined in Section 341.4.9.4., "Exempt Production," the Engineer will test one per day if 100 tons or more are produced. For Exempt Production, no testing is required when less than 100 tons are produced.
2. Not required when a thermal imaging system is used.
3. Testing performed by the Construction Division or designated laboratory.
4. The Engineer may reduce or waive the sampling and testing requirements based on a satisfactory test history.
5. Testing performed by the Construction Division and for informational purposes only.

4.9.2.4. **Operational Tolerances.** Control the production process within the operational tolerances listed in Table 11. When production is suspended, the Engineer will allow production to resume when test results or other information indicates the next mixture produced will be within the operational tolerances.

4.9.2.4.1. **Gradation.** Suspend operation and take corrective action if any aggregate is retained on the maximum sieve size shown in Table 8. A subplot is defined as out of tolerance if either the Engineer's or the Contractor's test results are out of operational tolerance. Suspend production when test results for gradation exceed the operational tolerances for 3 consecutive sublots on the same sieve or 4 consecutive sublots on any sieve unless otherwise directed. The consecutive sublots may be from more than one lot.

4.9.2.4.2. **Asphalt Binder Content.** A subplot is defined as out of operational tolerance if either the Engineer's or the Contractor's test results exceed the values listed in Table 11. No production or placement payment adjustments greater than 1.000 will be paid for any subplot that is out of operational tolerance for asphalt binder content. Suspend production and shipment of the mixture if the Engineer's or the Contractor's asphalt binder content deviates from the current JMF by more than 0.5% for any subplot.

4.9.2.4.3. **Void in Mineral Aggregates (VMA).** The Engineer will determine the VMA for every subplot. For sublots when the Engineer does not determine asphalt binder content, the Engineer will use the asphalt binder content results from QC testing performed by the Contractor to determine VMA.

Take immediate corrective action if the VMA value for any subplot is less than the minimum VMA requirement for production listed in Table 8. Suspend production and shipment of the mixture if the Engineer's VMA results on 2 consecutive sublots are below the minimum VMA requirement for production listed in Table 8. No production or placement payment adjustments greater than 1.000 will be paid for any subplot that does not meet the minimum VMA requirement for production listed in Table 8 based on the Engineer's VMA determination.

Suspend production and shipment of the mixture if the Engineer's VMA result is more than 0.5% below the minimum VMA requirement for production listed in Table 8. In addition to suspending production, the Engineer may require removal and replacement or may allow the subplot to be left in place without payment.

- 4.9.2.4.4. **Hamburg Wheel Test.** The Engineer may perform a Hamburg Wheel test at any time during production, including when the boil test indicates a change in quality from the materials submitted for JMF1. In addition to testing production samples, the Engineer may obtain cores and perform Hamburg Wheel tests on any areas of the roadway where rutting is observed. Suspend production until further Hamburg Wheel tests meet the specified values when the production or core samples fail the Hamburg Wheel test criteria in Table 10. Core samples, if taken, will be obtained from the center of the finished mat or other areas excluding the vehicle wheel paths. The Engineer may require up to the entire subplot of any mixture failing the Hamburg Wheel test to be removed and replaced at the Contractor's expense.

If the Department's or Department approved laboratory's Hamburg Wheel test results in a "remove and replace" condition, the Contractor may request that the Department confirm the results by re-testing the failing material. The Construction Division will perform the Hamburg Wheel tests and determine the final disposition of the material in question based on the Department's test results.

- 4.9.2.5. **Individual Loads of Hot-Mix.** The Engineer can reject individual truckloads of hot-mix. When a load of hot-mix is rejected for reasons other than temperature, contamination, or excessive uncoated particles, the Contractor may request that the rejected load be tested. Make this request within 4 hr. of rejection. The Engineer will sample and test the mixture. If test results are within the operational tolerances shown in Table 11, payment will be made for the load. If test results are not within operational tolerances, no payment will be made for the load.

4.9.3. **Placement Acceptance.**

- 4.9.3.1. **Placement Lot.** A placement lot consists of 4 placement sublots. A placement subplot consists of the area placed during a production subplot.

- 4.9.3.1.1. **Lot 1 Placement.** Placement payment adjustments greater than 1.000 for Lot 1 will be in accordance with Section 341.6.2., "Placement Payment Adjustment Factors"; however, no placement adjustment less than 1.000 will be assessed for any subplot placed in Lot 1 when the in-place air voids are greater than or equal to 2.7% and less than or equal to 9.9%. Remove and replace any subplot with in-place air voids less than 2.7% or greater than 9.9%.

- 4.9.3.1.2. **Incomplete Placement Lots.** An incomplete placement lot consists of the area placed as described in Section 341.4.9.2.1.1., "Incomplete Production Lots," excluding areas defined in Section 341.4.9.3.1.4., "Miscellaneous Areas." Placement sampling is required if the random sample plan for production resulted in a sample being obtained from an incomplete production subplot.

- 4.9.3.1.3. **Shoulders, Ramps, Etc.** Shoulders, ramps, intersections, acceleration lanes, deceleration lanes, and turn lanes are subject to in-place air void determination and payment adjustments unless designated on the plans as not eligible for in-place air void determination. Intersections may be considered miscellaneous areas when determined by the Engineer.

- 4.9.3.1.4. **Miscellaneous Areas.** Miscellaneous areas include areas that typically involve significant handwork or discontinuous paving operations, such as temporary detours, driveways, mailbox turnouts, crossovers, gores, spot level-up areas, and other similar areas. Temporary detours are subject to in-place air void determination when shown on the plans. Miscellaneous areas also include level-ups and thin overlays when the layer thickness specified on the plans is less than the minimum untrimmed core height eligible for testing shown in Table 12. The specified layer thickness is based on the rate of 110 lb./sq. yd. for each inch of pavement unless another rate is shown on the plans. When "level up" is listed as part of the item bid description code, a payment adjustment factor of 1.000 will be assigned for all placement sublots as described in Article 341.6, "Payment." Miscellaneous areas are not eligible for random placement sampling locations. Compact miscellaneous areas in accordance with Section 341.4.8., "Compaction." Miscellaneous

areas are not subject to in-place air void determination, thermal profiles testing, segregation (density profiles), or longitudinal joint density evaluations.

4.9.3.2.

Placement Sampling. The Engineer will select random numbers for all placement sublots at the beginning of the project. The Engineer will provide the Contractor with the placement random numbers immediately after the subplot is completed. Mark the roadway location at the completion of each subplot and record the station number. Determine one random sample location for each placement subplot in accordance with Tex-225-F. Adjust the random sample location by no more than necessary to achieve a 2-ft. clearance if the location is within 2 ft. of a joint or pavement edge.

Shoulders, ramps, intersections, acceleration lanes, deceleration lanes, and turn lanes are always eligible for selection as a random sample location; however, if a random sample location falls on one of these areas and the area is designated on the plans as not subject to in-place air void determination, cores will not be taken for the subplot and a 1.000 pay factor will be assigned to that subplot.

Provide the equipment and means to obtain and trim roadway cores on site. On-site is defined as in close proximity to where the cores are taken. Obtain the cores within one working day of the time the placement subplot is completed unless otherwise approved. Obtain two 6-in. diameter cores side-by-side from within 1 ft. of the random location provided for the placement subplot. For Type D and Type F mixtures, 4-in. diameter cores are allowed. Mark the cores for identification, measure and record the untrimmed core height, and provide the information to the Engineer. The Engineer will witness the coring operation and measurement of the core thickness. Visually inspect each core and verify that the current paving layer is bonded to the underlying layer. Take corrective action if an adequate bond does not exist between the current and underlying layer to ensure that an adequate bond will be achieved during subsequent placement operations.

Trim the cores immediately after obtaining the cores from the roadway in accordance with Tex-207-F if the core heights meet the minimum untrimmed value listed in Table 12. Trim the cores on site in the presence of the Engineer. Use a permanent marker or paint pen to record the lot and subplot numbers on each core as well as the designation as Core A or B. The Engineer may require additional information to be marked on the core and may choose to sign or initial the core. The Engineer will take custody of the cores immediately after they are trimmed and will retain custody of the cores until the Department's testing is completed. Before turning the trimmed cores over to the Engineer, the Contractor may wrap the trimmed cores or secure them in a manner that will reduce the risk of possible damage occurring during transport by the Engineer. After testing, the Engineer will return the cores to the Contractor.

The Engineer may have the cores transported back to the Department's laboratory at the HMA plant via the Contractor's haul truck or other designated vehicle. In such cases where the cores will be out of the Engineer's possession during transport, the Engineer will use Department-provided security bags and the Roadway Core Custody protocol located at <http://www.txdot.gov/business/specifications.htm> to provide a secure means and process that protects the integrity of the cores during transport.

Decide whether to include the pair of cores in the air void determination for that subplot if the core height before trimming is less than the minimum untrimmed value shown in Table 12. Trim the cores as described above before delivering to the Engineer if electing to have the cores included in the air void determination. Deliver untrimmed cores to the Engineer and inform the Engineer of the decision to not have the cores included in air void determination if electing to not have the cores included in air void determination. The placement pay factor for the subplot will be 1.000 if cores will not be included in air void determination.

Instead of the Contractor trimming the cores on site immediately after coring, the Engineer and the Contractor may mutually agree to have the trimming operations performed at an alternate location such as a field laboratory or other similar location. In such cases, the Engineer will take possession of the cores immediately after they are obtained from the roadway and will retain custody of the cores until testing is completed. Either the Department or Contractor representative may perform trimming of the cores. The Engineer will witness all trimming operations in cases where the Contractor representative performs the trimming operation.

Dry the core holes and tack the sides and bottom immediately after obtaining the cores. Fill the hole with the same type of mixture and properly compact the mixture. Repair core holes with other methods when approved.

4.9.3.3. **Placement Testing.** Perform placement tests in accordance with Table 14. After the Engineer returns the cores, the Contractor may test the cores to verify the Engineer's test results for in-place air voids. The allowable differences between the Contractor's and Engineer's test results are listed in Table 11.

4.9.3.3.1. **In-Place Air Voids.** The Engineer will measure in-place air voids in accordance with Tex-207-F and Tex-227-F. Before drying to a constant weight, cores may be pre-dried using a Corelok or similar vacuum device to remove excess moisture. The Engineer will average the values obtained for all sublots in the production lot to determine the theoretical maximum specific gravity. The Engineer will use the average air void content for in-place air voids.

The Engineer will use the vacuum method to seal the core if required by Tex-207-F. The Engineer will use the test results from the unsealed core to determine the placement payment adjustment factor if the sealed core yields a higher specific gravity than the unsealed core. After determining the in-place air void content, the Engineer will return the cores and provide test results to the Contractor.

4.9.3.3.2. **Segregation (Density Profile).** Test for segregation using density profiles in accordance with Tex-207-F, Part V. Density profiles are not required and are not applicable when using a thermal imaging system. Density profiles are not applicable in areas described in Section 341.4.9.3.1.4., "Miscellaneous Areas."

Perform a density profile every time the paver stops for more than 60 sec. on areas that are identified by either the Contractor or the Engineer as having thermal segregation and on any visibly segregated areas unless otherwise approved. Perform a minimum of one profile per subplot if the paver does not stop for more than 60 sec. and there are no visibly segregated areas or areas that are identified as having thermal segregation.

Provide the Engineer with the density profile of every subplot in the lot within one working day of the completion of each lot. Report the results of each density profile in accordance with Section 341.4.2., "Reporting and Responsibilities."

The density profile is considered failing if it exceeds the tolerances in Table 15. No production or placement payment adjustments greater than 1.000 will be paid for any subplot that contains a failing density profile. When a hand-held thermal camera is used instead of a thermal imaging system, the Engineer will measure the density profile at least once per project. The Engineer's density profile results will be used when available. The Engineer may require the Contractor to remove and replace the area in question if the area fails the density profile and has surface irregularities as defined in Section 341.4.9.3.3.5., "Irregularities." The subplot in question may receive a production and placement payment adjustment greater than 1.000, if applicable, when the defective material is successfully removed and replaced.

Investigate density profile failures and take corrective actions during production and placement to eliminate the segregation. Suspend production if 2 consecutive density profiles fail unless otherwise approved. Resume production after the Engineer approves changes to production or placement methods.

Table 15
Segregation (Density Profile) Acceptance Criteria

Mixture Type	Maximum Allowable Density Range (Highest to Lowest)	Maximum Allowable Density Range (Average to Lowest)
Type A & Type B	8.0 pcf	5.0 pcf
Type C, Type D & Type F	6.0 pcf	3.0 pcf

4.9.3.3.3. **Longitudinal Joint Density.**

4.9.3.3.3.1. **Informational Tests.** Perform joint density evaluations while establishing the rolling pattern and verify that the joint density is no more than 3.0 pcf below the density taken at or near the center of the mat. Adjust the

rolling pattern, if needed, to achieve the desired joint density. Perform additional joint density evaluations, at least once per subplot, unless otherwise directed.

- 4.9.3.3.2. **Record Tests.** Perform a joint density evaluation for each subplot at each pavement edge that is or will become a longitudinal joint. Joint density evaluations are not applicable in areas described in Section 341.4.9.3.1.4., "Miscellaneous Areas." Determine the joint density in accordance with Tex-207-F, Part VII. Record the joint density information and submit results on Department forms to the Engineer. The evaluation is considered failing if the joint density is more than 3.0 pcf below the density taken at the core random sample location and the correlated joint density is less than 90.0%. The Engineer will make independent joint density verification at least once per project and may make independent joint density verifications at the random sample locations. The Engineer's joint density test results will be used when available.

Provide the Engineer with the joint density of every subplot in the lot within one working day of the completion of each lot. Report the results of each joint density in accordance with Section 341.4.2., "Reporting and Responsibilities."

Investigate joint density failures and take corrective actions during production and placement to improve the joint density. Suspend production if the evaluations on 2 consecutive sublots fail unless otherwise approved. Resume production after the Engineer approves changes to production or placement methods.

- 4.9.3.3.4. **Recovered Asphalt Dynamic Shear Rheometer (DSR).** The Engineer may take production samples or cores from suspect areas of the project to determine recovered asphalt properties. Asphalt binders with an aging ratio greater than 3.5 do not meet the requirements for recovered asphalt properties and may be deemed defective when tested and evaluated by the Construction Division. The aging ratio is the DSR value of the extracted binder divided by the DSR value of the original unaged binder. Obtain DSR values in accordance with AASHTO T 315 at the specified high temperature performance grade of the asphalt. The Engineer may require removal and replacement of the defective material at the Contractor's expense. The asphalt binder will be recovered for testing from production samples or cores in accordance with Tex-211-F.

- 4.9.3.3.5. **Irregularities.** Identify and correct irregularities including segregation, rutting, raveling, flushing, fat spots, mat slippage, irregular color, irregular texture, roller marks, tears, gouges, streaks, uncoated aggregate particles, or broken aggregate particles. The Engineer may also identify irregularities, and in such cases, the Engineer will promptly notify the Contractor. If the Engineer determines that the irregularity will adversely affect pavement performance, the Engineer may require the Contractor to remove and replace (at the Contractor's expense) areas of the pavement that contain irregularities and areas where the mixture does not bond to the existing pavement.

If irregularities are detected, the Engineer may require the Contractor to immediately suspend operations or may allow the Contractor to continue operations for no more than one day while the Contractor is taking appropriate corrective action.

- 4.9.4. **Exempt Production.** The Engineer may deem the mixture as exempt production for the following conditions:

- anticipated daily production is less than 1,000 tons;
- total production for the project is less than 5,000 tons;
- when mutually agreed between the Engineer and the Contractor; or
- when shown on the plans.

For exempt production, the Contractor is relieved of all production and placement sampling and testing requirements, and the production and placement pay factors are 1.000. All other specification requirements apply, and the Engineer will perform acceptance tests for production and placement listed in Table 14 when 100 tons or more per day are produced.

For exempt production:

- produce, haul, place, and compact the mixture in compliance with the specification and as directed;

- control mixture production to yield a laboratory-molded density that is within $\pm 1.0\%$ of the target laboratory-molded density as tested by the Engineer;
- compact the mixture in accordance with Section 341.4.8., "Compaction;" and
- when a thermal imaging system is not used, the Engineer may perform segregation (density profiles) and thermal profiles in accordance with the specification.

4.9.5. **Ride Quality.** Measure ride quality in accordance with Item 585, "Ride Quality for Pavement Surfaces," unless otherwise shown on the plans.

5. MEASUREMENT

Hot mix will be measured by the ton of composite hot-mix, which includes asphalt, aggregate, and additives. Measure the weight on scales in accordance with Item 520, "Weighing and Measuring Equipment."

6. PAYMENT

The work performed and materials furnished in accordance with this Item and measured as provided under Section 341.5., "Measurement," will be paid for at the unit bid price for "Dense Graded Hot-Mix Asphalt" of the mixture type, SAC, and binder specified. These prices are full compensation for surface preparation, materials including tack coat, placement, equipment, labor, tools, and incidentals.

Payment adjustments will be applied as determined in this Item; however, a payment adjustment factor of 1.000 will be assigned for all placement sublots for "level ups" only when "level up" is listed as part of the item bid description code. A payment adjustment factor of 1.000 will be assigned to all production and placement sublots when "exempt" is listed as part of the item bid description code.

Payment for each subplot, including applicable payment adjustments greater than 1.000, will only be paid for sublots when the Contractor supplies the Engineer with the required documentation for production and placement QC/QA, thermal profiles, segregation density profiles, and longitudinal joint densities in accordance with Section 341.4.2., "Reporting and Responsibilities." When a thermal imaging system is used, documentation is not required for thermal profiles or segregation density profiles on individual sublots; however, the thermal imaging system automated reports described in Tex-244-F are required.

Trial batches will not be paid for unless they are included in pavement work approved by the Department.

Payment adjustment for ride quality will be determined in accordance with Item 585, "Ride Quality for Pavement Surfaces."

6.1. **Production Payment Adjustment Factors.** The production payment adjustment factor is based on the laboratory-molded density using the Engineer's test results. A payment adjustment factor will be determined from Table 16 for each subplot using the deviation from the target laboratory-molded density defined in Table 9. The production payment adjustment factor for completed lots will be the average of the payment adjustment factors for the 4 sublots sampled within that lot.

Table 16
Production Payment Adjustment Factors for Laboratory-Molded Density¹

Absolute Deviation from Target Laboratory-Molded Density	Production Payment Adjustment Factor (Target Laboratory-Molded Density)
0.0	1.050
0.1	1.050
0.2	1.050
0.3	1.044
0.4	1.038
0.5	1.031
0.6	1.025
0.7	1.019
0.8	1.013
0.9	1.006
1.0	1.000
1.1	0.965
1.2	0.930
1.3	0.895
1.4	0.860
1.5	0.825
1.6	0.790
1.7	0.755
1.8	0.720
> 1.8	Remove and replace

1. If the Engineer's laboratory-molded density on any subplot is less than 95.0% or greater than 98.0%, take immediate corrective action to bring the mixture within these tolerances. The Engineer may suspend operations if the Contractor's corrective actions do not produce acceptable results. The Engineer will allow production to resume when the proposed corrective action is likely to yield acceptable results.

- 6.1.1. **Payment for Incomplete Production Lots.** Production payment adjustments for incomplete lots, described under Section 341.4.9.2.1.1., "Incomplete Production Lots," will be calculated using the average production payment factors from all sublots sampled. A production payment factor of 1.000 will be assigned to any lot when the random sampling plan did not result in collection of any samples.
- 6.1.2. **Production Sublots Subject to Removal and Replacement.** If after referee testing, the laboratory-molded density for any subplot results in a "remove and replace" condition as listed in Table 16, the Engineer may require removal and replacement or may allow the subplot to be left in place without payment. The Engineer may also accept the subplot in accordance with Section 5.3.1., "Acceptance of Defective or Unauthorized Work." Replacement material meeting the requirements of this Item will be paid for in accordance with this Section.
- 6.2. **Placement Payment Adjustment Factors.** The placement payment adjustment factor is based on in-place air voids using the Engineer's test results. A payment adjustment factor will be determined from Table 17 for each subplot that requires in-place air void measurement. A placement payment adjustment factor of 1.000 will be assigned to the entire subplot when the random sample location falls in an area designated on the plans as not subject to in-place air void determination. A placement payment adjustment factor of 1.000 will be assigned to quantities placed in areas described in Section 341.4.9.3.1.4., "Miscellaneous Areas." The placement payment adjustment factor for completed lots will be the average of the placement payment adjustment factors for up to 4 sublots within that lot.

Table 17
Placement Payment Adjustment Factors for In-Place Air Voids

In-Place Air Voids	Placement Pay Adjustment Factor	In-Place Air Voids	Placement Pay Adjustment Factor
< 2.7	Remove and Replace	6.4	1.042
2.7	0.710	6.5	1.040
2.8	0.740	6.6	1.038
2.9	0.770	6.7	1.036
3.0	0.800	6.8	1.034
3.1	0.830	6.9	1.032
3.2	0.860	7.0	1.030
3.3	0.890	7.1	1.028
3.4	0.920	7.2	1.026
3.5	0.950	7.3	1.024
3.6	0.980	7.4	1.022
3.7	0.998	7.5	1.020
3.8	1.002	7.6	1.018
3.9	1.006	7.7	1.016
4.0	1.010	7.8	1.014
4.1	1.014	7.9	1.012
4.2	1.018	8.0	1.010
4.3	1.022	8.1	1.008
4.4	1.026	8.2	1.006
4.5	1.030	8.3	1.004
4.6	1.034	8.4	1.002
4.7	1.038	8.5	1.000
4.8	1.042	8.6	0.998
4.9	1.046	8.7	0.996
5.0	1.050	8.8	0.994
5.1	1.050	8.9	0.992
5.2	1.050	9.0	0.990
5.3	1.050	9.1	0.960
5.4	1.050	9.2	0.930
5.5	1.050	9.3	0.900
5.6	1.050	9.4	0.870
5.7	1.050	9.5	0.840
5.8	1.050	9.6	0.810
5.9	1.050	9.7	0.780
6.0	1.050	9.8	0.750
6.1	1.048	9.9	0.720
6.2	1.046	> 9.9	Remove and Replace
6.3	1.044		

6.2.1. **Payment for Incomplete Placement Lots.** Payment adjustments for incomplete placement lots described under Section 341.4.9.3.1.2., "Incomplete Placement Lots," will be calculated using the average of the placement payment factors from all sublots sampled and sublots where the random location falls in an area designated on the plans as not eligible for in-place air void determination. A placement payment adjustment factor of 1.000 will be assigned to any lot when the random sampling plan did not result in collection of any samples.

6.2.2. **Placement Sublots Subject to Removal and Replacement.** If after referee testing, the placement payment adjustment factor for any subplot results in a "remove and replace" condition as listed in Table 17, the Engineer will choose the location of 2 cores to be taken within 3 ft. of the original failing core location. The Contractor will obtain the cores in the presence of the Engineer. The Engineer will take immediate possession of the untrimmed cores and submit the untrimmed cores to the Construction Division, where they will be trimmed if necessary and tested for bulk specific gravity within 10 working days of receipt.

The average bulk specific gravity of the cores will be divided by the Engineer's average maximum theoretical specific gravity for that lot to determine the new payment adjustment factor of the subplot in question. If the new payment adjustment factor is 0.700 or greater, the new payment adjustment factor will apply to that

sublot. If the new payment adjustment factor is less than 0.700, no payment will be made for the sublot. Remove and replace the failing sublot, or the Engineer may allow the sublot to be left in place without payment. The Engineer may also accept the sublot in accordance with Section 5.3.1., "Acceptance of Defective or Unauthorized Work." Replacement material meeting the requirements of this Item will be paid for in accordance with this Section.

- 6.3. **Total Adjusted Pay Calculation.** Total adjusted pay (TAP) will be based on the applicable payment adjustment factors for production and placement for each lot.

$$TAP = (A+B)/2$$

where:

A = Bid price × production lot quantity × average payment adjustment factor for the production lot

B = Bid price × placement lot quantity × average payment adjustment factor for the placement lot + (bid price × quantity placed in miscellaneous areas × 1.000)

Production lot quantity = Quantity actually placed - quantity left in place without payment

Placement lot quantity = Quantity actually placed - quantity left in place without payment - quantity placed in miscellaneous areas

Item 342

Permeable Friction Course



1. DESCRIPTION

Construct a hot-mix asphalt (HMA) surface course composed of a compacted permeable mixture of aggregate, asphalt binder, and additives mixed hot in a mixing plant.

2. MATERIALS

Furnish uncontaminated materials of uniform quality that meet the requirements of the plans and specifications.

Notify the Engineer of all material sources and before changing any material source or formulation. The Engineer will verify that the specification requirements are met when the Contractor makes a source or formulation change, and may require a new laboratory mixture design, trial batch, or both. The Engineer may sample and test project materials at any time during the project to verify specification compliance in accordance with Item 6, "Control of Materials."

- 2.1. **Aggregate.** Furnish aggregates from sources that conform to the requirements shown in Table 1 and as specified in this Section. Aggregate requirements in this Section, including those shown in Table 1, may be modified or eliminated when shown on the plans. Additional aggregate requirements may be specified when shown on the plans. Provide aggregate stockpiles that meet the definitions in this Section for coarse aggregate. Do not use intermediate or fine aggregate in permeable friction course (PFC) mixtures. Aggregate from reclaimed asphalt pavement (RAP) is not required to meet Table 1 requirements unless otherwise shown on the plans. Supply aggregates that meet the definitions in Tex-100-E for crushed gravel or crushed stone. The Engineer will designate the plant or the quarry as the sampling location. Provide samples from materials produced for the project. The Engineer will establish the Surface Aggregate Classification (SAC) and perform Los Angeles abrasion, magnesium sulfate soundness, and Micro-Deval tests. Perform all other aggregate quality tests listed in Table 1. Document all test results on the mixture design report. The Engineer may perform tests on independent or split samples to verify Contractor test results. Stockpile aggregates for each source and type separately. Determine aggregate gradations for mixture design and production testing based on the washed sieve analysis given in Tex-200-F, Part II.

- 2.1.1. **Coarse Aggregate.** Coarse aggregate stockpiles must have no more than 20% material passing the No. 8 sieve. Aggregates from sources listed in the Department's *Bituminous Rated Source Quality Catalog* (BRSQC) are preapproved for use. Use only the rated values for hot-mix listed in the BRSQC. Rated values for surface treatment (ST) do not apply to coarse aggregate sources used in hot-mix asphalt.

For sources not listed on the Department's BRSQC:

- build an individual stockpile for each material;
- request the Department test the stockpile for specification compliance; and
- once approved, do not add material to the stockpile unless otherwise approved.

Provide aggregate from non-listed sources only when tested by the Engineer and approved before use. Allow 30 calendar days for the Engineer to sample, test, and report results for non-listed sources.

Provide coarse aggregate with at least the minimum SAC shown on the plans. SAC requirements only apply to aggregates used on the surface of travel lanes. SAC requirements apply to aggregates used on surfaces other than travel lanes when shown on the plans. The SAC for sources on the Department's *Aggregate Quality Monitoring Program* (AQMP) (Tex-499-A) is listed in the BRSQC.

- 2.1.1.1. **Blending Class A and Class B Aggregates.** Class B aggregate meeting all other requirements in Table 1 may be blended with a Class A aggregate to meet requirements for Class A materials; however, Class B virgin (non-recycled) aggregate may be disallowed when shown on the plans. Ensure that at least 50% by weight, or volume if required, of the material retained on the No. 4 sieve comes from the Class A aggregate source when blending Class A and B aggregates to meet a Class A requirement. Blend by volume if the bulk specific gravities of the Class A and B aggregates differ by more than 0.300. Coarse aggregate from RAP and Recycled Asphalt Shingles (RAS) will be considered as Class B aggregate for blending purposes.

The Engineer may perform tests at any time during production, when the Contractor blends Class A and B aggregates to meet a Class A requirement, to ensure that at least 50% by weight, or volume if required, of the material retained on the No. 4 sieve comes from the Class A aggregate source. The Engineer will use the Department's mix design template, when electing to verify conformance, to calculate the percent of Class A aggregate retained on the No. 4 sieve by inputting the bin percentages shown from readouts in the control room at the time of production and stockpile gradations measured at the time of production. The Engineer may determine the gradations based on either washed or dry sieve analysis from samples obtained from individual aggregate cold feed bins or aggregate stockpiles. The Engineer may perform spot checks using the gradations supplied by the Contractor on the mixture design report as an input for the template; however, a failing spot check will require confirmation with a stockpile gradation determined by the Engineer.

- 2.1.1.2. **Micro-Deval Abrasion.** The Engineer will perform a minimum of one Micro-Deval abrasion test in accordance with Tex-461-A for each coarse aggregate source used in the mixture design that has a Rated Source Soundness Magnesium (RSSM) loss value greater than 15 as listed in the BRSQC. The Engineer will perform testing before the start of production and may perform additional testing at any time during production. The Engineer may obtain the coarse aggregate samples from each coarse aggregate source or may require the Contractor to obtain the samples. The Engineer may waive all Micro-Deval testing based on a satisfactory test history of the same aggregate source.

The Engineer will estimate the magnesium sulfate soundness loss for each coarse aggregate source, when tested, using the following formula:

$$Mg_{est.} = (RSSM)(MD_{act}/RSMD)$$

where:

$Mg_{est.}$ = magnesium sulfate soundness loss

$MD_{act.}$ = actual Micro-Deval percent loss

$RSMD$ = Rated Source Micro-Deval

When the estimated magnesium sulfate soundness loss is greater than the maximum magnesium sulfate soundness loss specified, the coarse aggregate source will not be allowed for use unless otherwise approved. The Engineer will consult the Geotechnical, Soils, and Aggregates Branch of the Construction Division, and additional testing may be required before granting approval.

Table 1
Coarse Aggregate Quality Requirements

Property	Test Method	Requirement
SAC	Tex-499-A (AQMP)	As shown on the plans
Deleterious material, %, Max	Tex-217-F, Part I	1.0
Decantation, %, Max	Tex-217-F, Part II	1.5
Micro-Deval abrasion, %	Tex-461-A	Note ¹
Los Angeles abrasion, %, Max	Tex-410-A	30
Magnesium sulfate soundness, 5 cycles, %, Max	Tex-411-A	20
Crushed face count, ² %, Min	Tex-460-A, Part I	95
Flat and elongated particles @ 5:1, %, Max	Tex-280-F	10

1. Used to estimate the magnesium sulfate soundness loss in accordance with Section 342.2.1.1.2., "Micro-Deval Abrasion."

2. Only applies to crushed gravel.

- 2.2. **Baghouse Fines.** Fines collected by the baghouse or other dust-collecting equipment may be reintroduced into the mixing drum.

- 2.3. **Asphalt Binder.** Furnish the type and grade of binder specified on the plans that meets the requirements of Item 300, "Asphalts, Oils, and Emulsions."
- 2.3.1. **Performance-Graded (PG) Binder.** Provide an asphalt binder with a high-temperature grade of PG 76 and low-temperature grade as shown on the plans in accordance with Section 300.2.10., "Performance-Graded Binders," when PG binder is specified.
- 2.3.2. **Asphalt-Rubber (A-R) Binder.** Provide A-R binder that meets the Type I or Type II requirements of Section 300.2.9., "Asphalt-Rubber Binders," when A-R is specified unless otherwise shown on the plans. Use at least 15.0% by weight of Crumb Rubber Modifier (CRM) that meets the Grade B or Grade C requirements of Section 300.2.7., "Crumb Rubber Modifier," unless otherwise shown on the plans. Provide the Engineer the A-R binder blend design with the mix design (JMF1) submittal. Provide the Engineer with documentation such as the bill of lading showing the quantity of CRM used in the project unless otherwise directed.
- 2.4. **Tack Coat.** Furnish CSS-1H, SS-1H, or a PG binder with a minimum high-temperature grade of PG 58 for tack coat binder in accordance with Item 300, "Asphalts, Oils, and Emulsions." Specialized or preferred tack coat materials may be allowed or required when shown on the plans. Do not dilute emulsified asphalts at the terminal, in the field, or at any other location before use.
- The Engineer will obtain at least one sample of the tack coat binder per project in accordance with Tex-500-C, Part III, and test it to verify compliance with Item 300, "Asphalts, Oils, and Emulsions." The Engineer will obtain the sample from the asphalt distributor immediately before use.
- 2.5. **Additives.** Use the type and rate of additive specified when shown on the plans. Additives that facilitate mixing, compaction, or improve the quality of the mixture are allowed when approved. Provide the Engineer with documentation such as the bill of lading showing the quantity of additives used in the project unless otherwise directed.
- 2.5.1. **Fibers.** Provide cellulose or mineral fibers when PG binder is specified. Do not use fibers when A-R binder is specified. Submit written certification to the Engineer that the fibers proposed for use meet the requirements of DMS-9204, "Fiber Additives for Bituminous Mixtures." Fibers may be pre-blended into the binder at the asphalt supply terminal unless otherwise shown on the plans.
- When at least 3% RAS is used in the mixture, the Contractor may reduce the amount of fibers as specified in Table 4, Note 3.
- 2.5.2. **Lime Mineral Filler.** Add lime as mineral filler at a rate of 1.0% by weight of the total dry aggregate in accordance with Item 301, "Asphalt Antistripping Agents," unless otherwise shown on the plans or waived by the Engineer based on Hamburg Wheel test results. Do not add lime directly into the mixing drum of any plant where lime is removed through the exhaust stream unless the plant has a baghouse or dust collection system that reintroduces the lime into the drum.
- 2.5.3. **Lime and Liquid Antistripping Agent.** When lime or a liquid antistripping agent is used, add in accordance with Item 301, "Asphalt Antistripping Agents." Do not add lime directly into the mixing drum of any plant where lime is removed through the exhaust stream unless the plant has a baghouse or dust collection system that reintroduces the lime into the drum. When the plans require lime to be added as an antistripping agent, lime added as mineral filler will count towards the total quantity of lime specified.
- 2.5.4. **Warm Mix Asphalt (WMA).** Warm Mix Asphalt (WMA) is defined as HMA that is produced within a target temperature discharge range of 215°F and 275°F using approved WMA additives or processes from the Department's MPL.

WMA is allowed for use on all projects and is required when shown on the plans. When WMA is required, the maximum placement or target discharge temperature for WMA will be set at a value below 275°F.

Department-approved WMA additives or processes may be used to facilitate mixing and compaction of HMA produced at target discharge temperatures above 275°F; however, such mixtures will not be defined as WMA.

- 2.6. **Recycled Materials.** Use of RAP and RAS is permitted unless otherwise shown on the plans. Do not exceed the maximum allowable percentages of RAP and RAS shown in Table 2. The allowable percentages shown in Table 2 may be decreased or increased when shown on the plans. Determine asphalt binder content and gradation of the RAP and RAS stockpiles for mixture design purposes in accordance with Tex-236-F. The Engineer may verify the asphalt binder content of the stockpiles at any time during production. Perform other tests on RAP and RAS when shown on the plans. Asphalt binder from RAP and RAS is designated as recycled asphalt binder. Calculate and ensure that the ratio of the recycled asphalt binder to total binder does not exceed the percentages shown in Table 2 during mixture design and HMA production when RAP or RAS is used. Use a separate cold feed bin for each stockpile of RAP and RAS during HMA production.

- 2.6.1. **RAP.** RAP is salvaged, milled, pulverized, broken, or crushed asphalt pavement. Crush or break RAP so that 100% of the particles pass the 2 in. sieve. Fractionated RAP is defined as 2 or more RAP stockpiles, divided into coarse and fine fractions.

Use of Contractor-owned RAP, including HMA plant waste, is permitted unless otherwise shown on the plans. Department-owned RAP stockpiles are available for the Contractor's use when the stockpile locations are shown on the plans. If Department-owned RAP is available for the Contractor's use, the Contractor may use Contractor-owned fractionated RAP and replace it with an equal quantity of Department-owned RAP. Unfractionated RAP is not allowed in PFC mixtures. Department-owned RAP generated through required work on the Contract is available for the Contractor's use when shown on the plans. Perform any necessary tests to ensure Contractor- or Department-owned RAP is appropriate for use. The Department will not perform any tests or assume any liability for the quality of the Department-owned RAP unless otherwise shown on the plans. The Contractor will retain ownership of RAP generated on the project when shown on the plans.

The coarse RAP stockpile will contain only material retained by processing over a 3/8-in. or 1/2-in. screen unless otherwise approved. Fine RAP is not allowed in PFC mixtures. The Engineer may allow the Contractor to use an alternate to the 3/8-in. or 1/2-in. screen to fractionate the RAP.

Do not use Department- or Contractor-owned RAP contaminated with dirt or other objectionable materials.

Do not intermingle Contractor-owned RAP stockpiles with Department-owned RAP stockpiles. Remove unused Contractor-owned RAP material from the project site upon completion of the project. Return unused Department-owned RAP to the designated stockpile location.

- 2.6.2. **RAS.** Use of post-manufactured RAS or post-consumer RAS (tear-offs) is permitted unless otherwise shown on the plans. RAS is defined as processed asphalt shingle material from manufacturing of asphalt roofing shingles or from re-roofing residential structures. Post-manufactured RAS is processed manufacturer's shingle scrap by-product. Post-consumer RAS is processed shingle scrap removed from residential structures. Comply with all regulatory requirements stipulated for RAS by the TCEQ. RAS may be used separately or in conjunction with RAP.

Process the RAS by ambient grinding or granulating such that 100% of the particles pass the 3/8 in. sieve when tested in accordance with Tex-200-F, Part I. Perform a sieve analysis on processed RAS material before extraction (or ignition) of the asphalt binder.

Any stockpile that contains RAS will be considered a RAS stockpile and be limited to no more than 5.0% of the HMA mixture in accordance with Table 2.

Certify compliance of the RAS with DMS-11000, "Evaluating and Using Nonhazardous Recyclable Materials Guidelines." Treat RAS as an established nonhazardous recyclable material if it has not come into contact with any hazardous materials. Use RAS from shingle sources on the Department's MPL. Remove substantially all materials before use that are not part of the shingle, such as wood, paper, metal, plastic, and

felt paper. Determine the deleterious content of RAS material for mixture design purposes in accordance with Tex-217-F, Part III. Do not use RAS if deleterious materials are more than 0.5% of the stockpiled RAS unless otherwise approved. Submit a sample for approval before submitting the mixture design. The Department will perform the testing for deleterious material of RAS to determine specification compliance.

Table 2
Maximum Allowable Amounts of Recycled Binder, RAP, and RAS

Maximum Ratio of Recycled Binder to Total Binder ¹ (%)	Maximum Allowable Recycled Material ² (%)	
	Fractionated RAP ³	RAS ⁴
15.0	10.0	5.0

1. Combined recycled binder from fractionated RAP and RAS.
2. Unfractionated RAP is not allowed in PFC mixtures.
3. May replace up to 5% fractionated RAP with RAS.
4. May be used separately or as a replacement for no more than 5% of the allowable fractionated RAP.

3. EQUIPMENT

Provide required or necessary equipment in accordance with Item 320, "Equipment for Asphalt Concrete Pavement." When A-R binder is specified, equip the hot-mix plant with an in-line viscosity-measuring device located between the blending unit and the mixing drum. Provide a means to calibrate the asphalt mass flow meter on-site when a meter is used.

4. CONSTRUCTION

Produce, haul, place, and compact the specified paving mixture. In addition to tests required by the specification, Contractors may perform other QC tests as deemed necessary. At any time during the project, the Engineer may perform production and placement tests as deemed necessary in accordance with Item 5, "Control of the Work." Schedule and participate in a mandatory pre-paving meeting with the Engineer on or before the first day of paving unless otherwise shown on the plans.

- 4.1. **Certification.** Personnel certified by the Department-approved hot-mix asphalt certification program must conduct all mixture designs, sampling, and testing in accordance with Table 3. Supply the Engineer with a list of certified personnel and copies of their current certificates before beginning production and when personnel changes are made. Provide a mixture design developed and signed by a Level 2 certified specialist. Provide Level 1A certified specialists at the plant during production operations. Provide Level 1B certified specialists to conduct placement tests.

Table 3
Test Methods, Test Responsibility, and Minimum Certification Levels

Test Description	Test Method	Contractor	Engineer	Level ¹
1. Aggregate and Recycled Material Testing				
Sampling	Tex-221-F	✓	✓	1A
Dry sieve	Tex-200-F, Part I	✓	✓	1A
Washed sieve	Tex-200-F, Part II	✓	✓	1A
Deleterious material	Tex-217-F, Parts I & III	✓	✓	1A
Decantation	Tex-217-F, Part II	✓	✓	1A
Los Angeles abrasion	Tex-410-A		✓	TxDOT
Magnesium sulfate soundness	Tex-411-A		✓	TxDOT
Micro-Deval abrasion	Tex-461-A		✓	2
Crushed face count	Tex-460-A	✓	✓	2
Flat and elongated particles	Tex-280-F	✓	✓	2
2. Asphalt Binder & Tack Coat Sampling				
Asphalt binder sampling	Tex-500-C, Part II	✓	✓	1A/1B
Tack coat sampling	Tex-500-C, Part III	✓	✓	1A/1B
3. Mix Design & Verification				
Design and JMF changes	Tex-204-F	✓	✓	2
Mixing	Tex-205-F	✓	✓	2
Molding (SGC)	Tex-241-F	✓	✓	1A
Laboratory-molded density	Tex-207-F	✓	✓	1A
Rice gravity	Tex-227-F	✓	✓	1A
Ignition oven correction factors ²	Tex-236-F	✓	✓	2
Drain-down	Tex-235-F	✓	✓	1A
Hamburg Wheel test	Tex-242-F	✓	✓	2
Overlay test	Tex-248-F		✓	TxDOT
Boil test	Tex-530-C	✓	✓	1A
Cantabro loss	Tex-245-F	✓	✓	2
4. Production Testing				
Control charts	Tex-233-F	✓	✓	1A
Mixture sampling	Tex-222-F	✓	✓	1A
Gradation & asphalt binder content ²	Tex-236-F	✓	✓	1A
Moisture content	Tex-212-F	✓	✓	1A
Micro-Deval abrasion	Tex-461-A		✓	2
Drain-down	Tex-235-F	✓	✓	1A
Boil test	Tex-530-C	✓	✓	1A
Abson recovery	Tex-211-F		✓	TxDOT
5. Placement Testing				
Control charts	Tex-233-F	✓	✓	1A
Ride quality measurement	Tex-1001-S	✓	✓	Note ³
Thermal profile	Tex-244-F	✓	✓	1B
Permeability	Tex-246-F	✓	✓	1B

- Level 1A, 1B, and 2 are certification levels provided by the Hot Mix Asphalt Center certification program.
- Refer to Section 342.4.5., "Production Operations," for exceptions to using an ignition oven.
- Profiler and operator are required to be certified at the Texas A&M Transportation Institute facility when Surface Test Type B is specified.

4.2.

Reporting and Responsibilities. Use Department-provided templates to record and calculate all test data, including mixture design, production and placement tests, control charts, and thermal profiles. Obtain the current version of the templates at <http://www.txdot.gov/inside-txdot/forms-publications/consultants-contractors/forms/site-manager.html> or from the Engineer. The Engineer and the Contractor will provide any available test results to the other party when requested. The Engineer and the Contractor will immediately report to the other party any test result that requires suspension of production or placement or that fails to meet the specification requirements. Record and electronically submit all test results and pertinent information on Department-provided templates.

Subsequent sublots placed after test results are available to the Contractor, which require suspension of operations, may be considered unauthorized work. Unauthorized work will be accepted or rejected at the discretion of the Engineer in accordance with Article 5.3., "Conformity with Plans, Specifications, and Special Provisions."

Use the procedures described in Tex-233-F to plot the results of all production and placement testing, when directed. Update the control charts as soon as test results for each subplot become available. Make the control charts readily accessible at the field laboratory. The Engineer may suspend production for failure to update control charts.

- 4.3. **Quality Control Plan (QCP).** Develop and follow the QCP in detail. Obtain approval for changes to the QCP made during the project. The Engineer may suspend operations if the Contractor fails to comply with the QCP.
- Submit a written QCP before the mandatory pre-paving meeting when directed. Receive approval of the QCP before beginning production. Include the following items in the QCP:
- 4.3.1. **Project Personnel.** For project personnel, include:
- a list of individuals responsible for QC with authority to take corrective action;
 - current contact information for each individual listed; and
 - current copies of certification documents for individuals performing specified QC functions.
- 4.3.2. **Material Delivery and Storage.** For material delivery and storage, include:
- the sequence of material processing, delivery, and minimum quantities to assure continuous plant operations;
 - aggregate stockpiling procedures to avoid contamination and segregation;
 - frequency, type, and timing of aggregate stockpile testing to assure conformance of material requirements before mixture production; and
 - procedure for monitoring the quality and variability of asphalt binder.
- 4.3.3. **Production.** For production, include:
- loader operation procedures to avoid contamination in cold bins;
 - procedures for calibrating and controlling cold feeds;
 - procedures to eliminate debris or oversized material;
 - procedures for adding and verifying rates of each applicable mixture component (e.g., aggregate, asphalt binder, RAP, RAS, lime, liquid antistripping, WMA, fibers);
 - procedures for reporting job control test results; and
 - procedures to avoid segregation and drain-down in the silo.
- 4.3.4. **Loading and Transporting.** For loading and transporting, include:
- type and application method for release agents; and
 - truck loading procedures to avoid segregation.
- 4.3.5. **Placement and Compaction.** For placement and compaction, include:
- proposed agenda for mandatory pre-paving meeting, including date and location;
 - proposed paving plan (e.g., paving widths, joint offsets, and lift thicknesses);
 - type and application method for release agents in the paver and on rollers, shovels, lutes, and other utensils;
 - procedures for the transfer of mixture into the paver, while avoiding segregation and preventing material spillage;
 - process to balance production, delivery, paving, and compaction to achieve continuous placement operations and good ride quality;
 - paver operations (e.g., operation of wings, height of mixture in auger chamber) to avoid physical and thermal segregation and other surface irregularities; and
 - procedures to construct quality longitudinal and transverse joints.

4.4. Mixture Design.

4.4.1. **Design Requirements.** Use the PFC design procedure provided in Tex-204-F, unless otherwise shown on the plans. Design the mixture to meet the requirements listed in Tables 1, 2, and 4. Use a Superpave Gyrotory Compactor (SGC) at 50 gyrations as the design number of gyrations (Ndesign).

The Engineer will provide the mixture design when shown on the plans. The Contractor may submit a new mixture design at any time during the project. The Engineer will verify and approve all mixture designs (JMF1) before the Contractor can begin production.

Provide the Engineer with a mixture design report using the Department-provided template. Include the following items in the report:

- the combined aggregate gradation, source, specific gravity, and percent of each material used;
- asphalt binder content and aggregate gradation of RAP and RAS stockpiles;
- results of all applicable tests;
- the mixing and molding temperatures;
- the signature of the Level 2 person or persons that performed the design;
- the date the mixture design was performed; and
- a unique identification number for the mixture design.

Table 4
Master Gradation Limits (% Passing by Weight or Volume) and Laboratory Mixture Design Properties

Sieve Size	PG 76 Mixtures		A-R Mixtures		Test Procedure
	Fine (PFC-F)	Coarse (PFC-C)	Fine (PFCR-F)	Coarse (PFCR-C)	
3/4"	–	100.0 ¹	100.0 ¹	100.0 ¹	Tex-200-F
1/2"	100.0 ¹	80.0-100.0	95.0-100.0	80.0-100.0	
3/8"	95.0-100.0	35.0-60.0	50.0-80.0	35.0-60.0	
#4	20.0-55.0	1.0-20.0	0.0-8.0	0.0-20.0	
#8	1.0-10.0	1.0-10.0	0.0-4.0	0.0-10.0	
#200	1.0-4.0	1.0-4.0	0.0-4.0	0.0-4.0	
Mixture Properties					
Asphalt binder content, %	6.0-7.0	6.0-7.0	8.0-10.0	7.0-9.0	–
Design gyrations (Ndesign)	50	50	50	50	Tex-241-F
Lab-molded density, %	78.0 Max	82.0 Max	82.0 Max	82.0 Max	Tex-207-F
Hamburg Wheel test, ² passes at 12.5 mm rut depth	10,000 Min ³	Note ²	Note ²	Note ²	Tex-242-F
Overlay tester, ² number of cycles	200 Min	Note ²	Note ²	Note ²	Tex-248-F
Drain-down, %	0.10 Max	0.10 Max	0.10 Max	0.10 Max	Tex-235-F
Fiber content, % by wt. of total PG 76 mixture	0.20 ⁴ -0.50	0.20 ⁴ -0.50	–	–	Calculated
Lime content, % by wt. of total aggregate	1.0 ⁵	1.0 ⁵	1.0 ⁵	1.0 ⁵	Calculated
CRM content, % by wt. of A-R binder	–	–	15.0 Min	15.0 Min	Calculated
Boil test ⁶	–	–	–	–	Tex-530-C
Cantabro loss, %	20.0 Max	20.0 Max	20.0 Max	20.0 Max	Tex-245-F

1. Defined as maximum sieve size. No tolerance allowed.
2. Mold test specimens to Ndesign at the optimum asphalt binder content (JMF1). Perform the test for informational purposes only when no minimum number is specified.
3. May be decreased when approved.
4. The Contractor may reduce the amount of fibers to no less than 0.10%, provided the mixture meets the drain-down requirement, when at least 3% RAS is used in the mixture.
5. Unless otherwise shown on the plans or waived by the Engineer based on Hamburg Wheel results.
6. Used to establish baseline for comparison to production results. May be waived when approved.

4.4.2. **Job-Mix Formula Approval.** The job-mix formula (JMF) is the combined aggregate gradation, Ndesign level, and target asphalt percentage used to establish target values for hot-mix production. JMF1 is the original laboratory mixture design used to produce the trial batch. When WMA is used, JMF1 may be designed and

submitted to the Engineer without including the WMA additive. When WMA is used, document the additive or process used and recommended rate on the JMF1 submittal. The Engineer and the Contractor will verify JMF1 based on plant-produced mixture from the trial batch unless otherwise approved. The Engineer may accept an existing mixture design previously used on a Department project and may waive the trial batch to verify JMF1. The Department may require the Contractor to reimburse the Department for verification tests if more than 2 trial batches per design are required.

4.4.2.1. **Contractor's Responsibilities.**

4.4.2.1.1. **Gyratory Compactor.** Furnish an SGC calibrated in accordance with Tex-241-F for molding production samples. Locate the SGC at the Engineer's field laboratory and make the SGC available to the Engineer for use in molding production samples.

4.4.2.1.2. **Gyratory Compactor Correlation Factors.** Use Tex-206-F, Part II, to perform a gyratory compactor correlation when the Engineer uses a different SGC. Apply the correlation factor to all subsequent production test results.

4.4.2.1.3. **Hamburg and Overlay Testing.** Use an approved laboratory from the Department's MPL to perform the Hamburg Wheel test and provide results with the mixture design, or provide 10,000 g of the laboratory mixture and request that the Department perform the Hamburg Wheel test.

Provide 25,000 g of the laboratory mixture and request that the Department perform the Overlay test.

The Engineer will be allowed 10 working days to provide the Contractor with Hamburg Wheel and Overlay test results on the laboratory mixture design.

4.4.2.1.4. **Submitting JMF1.** Furnish a mix design report (JMF1) including Hamburg and Overlay results. Provide representative samples of all component materials and request approval to produce the trial batch.

4.4.2.1.5. **Supplying Aggregates.** Provide approximately 40 lb. of each aggregate stockpile unless otherwise directed.

4.4.2.1.6. **Supplying Asphalt.** Provide at least 1 gal. of the asphalt material and sufficient quantities of any additives proposed for use.

4.4.2.1.7. **Ignition Oven Correction Factors.** Determine the aggregate and asphalt correction factors from the ignition oven in accordance with Tex-236-F. Note that the asphalt content correction factor takes into account the percent fibers in the mixture so that the fibers are excluded from the binder content determination. Provide the Engineer with split samples of the mixtures before the trial batch production, including all additives (except water), and blank samples used to determine the correction factors for the ignition oven used for quality assurance (QA) testing during production. Correction factors established from a previously approved mixture design may be used for the current mixture design if the mixture design and ignition oven are the same as previously used unless otherwise directed.

4.4.2.1.8. **Boil Test.** Perform the test and retain the tested sample from Tex-530-C until completion of the project or as directed. Use this sample for comparison purposes during production. The Engineer may waive the requirement for the boil test. Add lime or liquid antistripping agent, as directed, if signs of stripping exist.

4.4.2.1.9. **Trial Batch Production.** Provide a plant-produced trial batch upon receiving conditional approval of JMF1 and authorization to produce a trial batch including the WMA additive or process, if applicable, for verification testing of JMF1 and development of JMF2. Produce a trial batch mixture that meets the requirements in Table 2 and Table 5. The Engineer may accept test results from recent production of the same mixture instead of a new trial batch.

4.4.2.1.10. **Trial Batch Production Equipment.** Use only equipment and materials proposed for use on the project to produce the trial batch. Provide documentation to verify the calibration or accuracy of the asphalt mass flow meter to measure the binder content. Verify that asphalt mass flow meter meets the requirements of 0.4%

accuracy, when required, in accordance with Item 520, "Weighing and Measuring Equipment." The Engineer may require that the accuracy of the mass flow meter be verified based on quantities used.

- 4.4.2.1.11. **Trial Batch Quantity.** Produce enough quantity of the trial batch to ensure that the mixture meets the specification requirements.
- 4.4.2.1.12. **Number of Trial Batches.** Produce trial batches as necessary to obtain a mixture that meets the specification requirements.
- 4.4.2.1.13. **Trial Batch Sampling.** Obtain a representative sample of the trial batch and split it into 3 equal portions in accordance with Tex-222-F. Label these portions as "Contractor," "Engineer," and "Referee." Deliver samples to the appropriate laboratory as directed.
- 4.4.2.1.14. **Trial Batch Testing.** Test the trial batch to ensure the mixture produced using the proposed JMF1 meets the mixture requirements in Table 5. Provide the Engineer with a copy of the trial batch test results.
- 4.4.2.1.15. **Development of JMF2.** Evaluate the trial batch test results, determine the target mixture proportions, and submit as JMF2 after the Engineer grants full approval of JMF1 based on results from the trial batch. Verify that JMF2 meets the mixture requirements in Table 2.
- 4.4.2.1.16. **Mixture Production.** Use JMF2 to produce Lot 1 after receiving approval for JMF2.
- 4.4.2.1.17. **Development of JMF3.** Evaluate the test results from Lot 1, determine the optimum mixture proportions, and submit as JMF3 for use in Lot 2.
- 4.4.2.1.18. **JMF Adjustments.** If JMF adjustments are necessary to achieve the specified requirements, make the adjustments before beginning a new lot. The adjusted JMF must:
- be provided to the Engineer in writing before the start of a new lot;
 - be numbered in sequence to the previous JMF;
 - meet the mixture requirements in Table 2;
 - meet the master gradation and binder content limits shown in Table 4; and
 - be within the operational tolerances of JMF2 listed in Table 5.
- 4.4.2.1.19. **Requesting Referee Testing.** Use referee testing, if needed, in accordance with Section 342.4.9.1., "Referee Testing," to resolve testing differences with the Engineer.

Table 5
Testing Frequency and Mixture Production Tolerances

Test Description	Test Method	Minimum Contractor Testing Frequency	Minimum Engineer Testing Frequency	Operational Tolerance from Current JMF
Individual % retained for sieve sized larger than #200	Tex-200-F	1 per subplot	1 per 12 sublots	±5.0 ¹
% passing the #200 sieve				±2.0 ¹
Laboratory-molded density, %	Tex-207-F, Part VIII	1 per subplot	1 per lot	Table 4
Asphalt binder content, %	Tex-236-F ²	1 per subplot	1 per lot ³	±0.3 ⁴
Drain-down, %	Tex-235-F	1 per subplot	1 per 12 sublots	Table 4
Boil test ⁵	Tex-530-C	1 per project	1 per project	N/A
Cantabro loss, %	Tex-245-F	1 per project (sample only)	1 per project	Table 4
Asphalt binder sampling	Tex-500-C	1 per lot (sample only)	1 per project	N/A
Tack coat sampling and testing	Tex-500-C, Part III	N/A	1 per project	N/A
Thermal profile	Tex-244-F	1 per subplot	Optional	N/A

1. Only applies to mixture produced for Lot 1 and higher. Aggregate gradation is not allowed to be outside the limits shown in Table 4.
2. Ensure the binder content determination excludes fibers. Add the recycled binder content to the flow meter readout when the asphalt mass flow meter is used to determine binder content.
3. May be obtained from asphalt mass flow meter readouts.
4. Binder content is not allowed to be outside the limits shown in Table 4.
5. The Engineer may reduce or waive the sampling and testing requirements based on a satisfactory test history.

4.4.2.2. **Engineer's Responsibilities.**

4.4.2.2.1. **Gyratory Compactor.** The Engineer will use a Department SGC calibrated in accordance with Tex-241-F to mold samples for laboratory mixture design verification. For molding trial batch and production specimens, the Engineer will use the Contractor-provided SGC at the field laboratory or provide and use a Department SGC at an alternate location. The Engineer will make the Contractor-provided SGC in the Department field laboratory available to the Contractor for molding verification samples.

4.4.2.2.2. **Hamburg Wheel and Overlay Testing.** At the Contractor's request, the Department will perform the Hamburg Wheel test on the laboratory mixture in accordance with Tex-242-F to verify compliance with the Hamburg Wheel test requirement in Table 4. The Department will perform the Overlay test in accordance with Tex-248-F to verify compliance with the Overlay test requirements in Table 4. The Engineer will be allowed 10 working days to provide the Contractor with Hamburg Wheel and Overlay test results on the laboratory mixture design.

4.4.2.2.3. **Conditional Approval of JMF1 and Authorizing Trial Batch.** The Engineer will review the Contractor's mix design report and verify specification conformance of the mixture and component materials. The Engineer will grant conditional approval of JMF1 within 2 working days of receiving the complete mixture design report (JMF1) and all required materials.

Unless waived, the Engineer will determine the Micro-Deval abrasion loss in accordance with Section 342.2.1.1.2., "Micro-Deval Abrasion." If the Engineer's test results are pending after 2 working days, conditional approval of JMF1 will still be granted within 2 working days of receiving JMF1. When the Engineer's test results become available, they will be used for specification compliance.

The Contractor is authorized to produce a trial batch after the Engineer grants conditional approval of JMF1.

4.4.2.2.4. **Ignition Oven Correction Factors.** The Engineer will use the split samples provided by the Contractor to determine the aggregate and asphalt correction factors for the ignition oven used for QA testing during production in accordance with Tex-236-F. The Engineer will verify that the asphalt content correction factor takes into account the percent fibers in the mixture so that the fibers are excluded from the binder content determination.

- 4.4.2.2.5. **Testing the Trial Batch.** Within 1 full working day, the Engineer will sample and test the trial batch to ensure that the mixture meets the requirements in Table 5.

The Engineer will have the option to perform the following tests on the trial batch:

- Tex-235-F, to verify that drain-down meets the requirements shown in Table 4;
- Tex-530-C, to retain and use for comparison purposes during production; and
- Tex-245-F, to verify the Cantabro loss meets the requirement shown in Table 4.

- 4.4.2.2.6. **Full Approval of JMF1.** The Engineer will grant full approval of JMF1 and authorize the Contractor to proceed with developing JMF2 if the Engineer's results for the trial batch meet the requirements in Table 5.

The Engineer will notify the Contractor that an additional trial batch is required if the trial batch does not meet these requirements.

- 4.4.2.2.7. **Approval of JMF2.** The Engineer will approve JMF2 within one working day if the mixture meets the requirements in Table 2 as well as the master grading limits and binder content shown in Table 4.

- 4.4.2.2.8. **Approval of Lot 1 Production.** The Engineer will authorize the Contractor to proceed with Lot 1 production (using JMF2).

- 4.4.2.2.9. **Approval of JMF3 and Subsequent JMF Changes.** JMF3 and subsequent JMF changes are approved if they meet the mixture requirements shown in Table 2 and the master grading and binder content limits shown in Table 4, and are within the operational tolerances of JMF2 shown in Table 5.

- 4.4.2.2.10. **Binder Content Adjustments.** For JMF2 and above, the Engineer may require the Contractor to adjust the target binder content by no more than 0.3% from the current JMF.

- 4.5. **Production Operations.** Perform a new trial batch when the plant or plant location is changed. Perform QC at the frequency and within the tolerances listed in Table 5. Take corrective action and receive approval to proceed after any production suspension for noncompliance to the specification. Submit a new mix design and perform a new trial batch when the asphalt binder content of:

- any RAP stockpile used in the mix is more than 0.5% higher than the value shown on the mixture design report; or
- RAS stockpile used in the mix is more than 2.0% higher than the value shown on the mixture design report.

At any time during production, the Engineer may require the Contractor to verify the following based on quantities used:

- lime content (within $\pm 0.1\%$ of JMF), when PG binder is specified;
- fiber content (within $\pm 0.03\%$ of JMF), when PG binder is specified; and
- CRM content (within $\pm 1.5\%$ of JMF), when A-R binder is specified.

Maintain the in-line measuring device when A-R binder is specified to verify the A-R binder viscosity between 2,500 and 4,000 centipoise at 350°F unless otherwise approved. Record A-R binder viscosity at least once per hour and provide the Engineer with a daily summary unless otherwise directed.

If the aggregate mineralogy is such that Tex-236-F does not yield reliable results, the Engineer may allow alternate methods for determining the asphalt content and aggregate gradation. The Engineer will require the Contractor to provide evidence that results from Tex-236-F are not reliable before permitting an alternate method unless otherwise allowed. Use the applicable test procedure as directed if an alternate test method is allowed.

- 4.5.1. **Storage and Heating of Materials.** Do not heat the asphalt binder above the temperatures specified in Item 300, "Asphalts, Oils, and Emulsions," or outside the manufacturer's recommended values. Provide the

Engineer with daily records of asphalt binder and hot-mix asphalt discharge temperatures (in legible and discernible increments) in accordance with Item 320, "Equipment for Asphalt Concrete Pavement," unless otherwise directed. Do not store mixture for a period long enough to affect the quality of the mixture, nor in any case longer than 12 hr. unless otherwise approved.

- 4.5.2. **Mixing and Discharge of Materials.** Notify the Engineer of the target discharge temperature and produce the mixture within 25°F of the target. Monitor the temperature of the material in the truck before shipping to ensure that it does not exceed 350°F (or 275°F for WMA) and is not lower than 215°F. The Department will not pay for or allow placement of any mixture produced above 350°F.

Produce WMA within the target discharge temperature range of 215°F and 275°F when WMA is required. Take corrective action any time the discharge temperature of the WMA exceeds the target discharge range. The Engineer may suspend production operations if the Contractor's corrective action is not successful at controlling the production temperature within the target discharge range. Note that when WMA is produced, it may be necessary to adjust burners to ensure complete combustion such that no burner fuel residue remains in the mixture.

Control the mixing time and temperature so that substantially all moisture is removed from the mixture before discharging from the plant. Determine the moisture content, if requested, by oven-drying in accordance with Tex-212-F, Part II, and verify that the mixture contains no more than 0.2% of moisture by weight. Obtain the sample immediately after discharging the mixture into the truck, and perform the test promptly.

- 4.6. **Hauling Operations.** Clean all truck beds before use to ensure that mixture is not contaminated. Use a release agent, when necessary, shown on the Department's MPL to coat the inside bed of the truck.

Use equipment for hauling as defined in Section 342.4.7.3.3., "Hauling Equipment." Use other hauling equipment only when allowed.

- 4.7. **Placement Operations.** Collect haul tickets from each load of mixture delivered to the project and provide the Department's copy to the Engineer approximately every hour or as directed. Use a hand-held thermal camera or infrared thermometer, when a thermal imaging system is not used, to measure and record the internal temperature of the mixture as discharged from the truck or Material Transfer Device (MTD) before or as the mix enters the paver and an approximate station number or GPS coordinates on each ticket. Calculate the daily yield and cumulative yield for the specified lift and provide to the Engineer at the end of paving operations for each day unless otherwise directed. The Engineer may suspend production if the Contractor fails to produce and provide haul tickets and yield calculations by the end of paving operations for each day.

Prepare the surface by removing raised pavement markers and objectionable material such as moisture, dirt, sand, leaves, and other loose impediments from the surface before placing mixture. Remove vegetation from pavement edges. Place the mixture to meet the typical section requirements and produce a smooth, finished surface with a uniform appearance and texture. Offset longitudinal joints of successive courses of hot-mix by at least 6 in. Place mixture so that longitudinal joints on the surface course coincide with lane lines, or as directed. Ensure that all finished surfaces will drain properly.

- 4.7.1. **Weather Conditions.**

- 4.7.1.1. **When Using a Thermal Imaging System.** The Contractor may pave any time the roadway is dry and the roadway surface temperature is at least 50°F; however, the Engineer may restrict the Contractor from paving if the ambient temperature is likely to drop below 32°F within 12 hr. of paving. Provide output data from the thermal imaging system to demonstrate to the Engineer that no recurring severe thermal segregation exists in accordance with Section 342.4.7.3.1.2., "Thermal Imaging System."

- 4.7.1.2. **When Not Using a Thermal Imaging System.** Place mixture when the roadway surface temperature is at or above 70°F unless otherwise approved or as shown on the plans. Measure the roadway surface temperature with a hand-held thermal camera or infrared thermometer. The Engineer may allow mixture placement to begin before the roadway surface reaches the required temperature if conditions are such that the roadway surface will reach the required temperature within 2 hr. of beginning placement operations. Place mixtures

only when weather conditions and moisture conditions of the roadway surface are suitable as determined by the Engineer. The Engineer may restrict the Contractor from paving if the ambient temperature is likely to drop below 32°F within 12 hr. of paving.

- 4.7.2. **Tack Coat.** Clean the surface before placing the tack coat. The Engineer will set the rate between 0.04 and 0.10 gal. of residual asphalt per square yard of surface area. Apply a uniform tack coat at the specified rate unless otherwise directed. Apply the tack coat in a uniform manner to avoid streaks and other irregular patterns. Apply a thin, uniform tack coat to all contact surfaces of curbs, structures, and all joints. Allow adequate time for emulsion to break completely before placing any material. Prevent splattering of tack coat when placed adjacent to curb, gutter, and structures. Roll the tack coat with a pneumatic-tire roller to remove streaks and other irregular patterns when directed.
- 4.7.3. **Lay-Down Operations.**
- 4.7.3.1. **Thermal Profile.** Use a hand-held thermal camera or a thermal imaging system to obtain a continuous thermal profile in accordance with Tex-244-F. Thermal profiles are not applicable in areas described in Section 342.4.9.4., "Miscellaneous Areas."
- 4.7.3.1.1. **Thermal Segregation.**
- 4.7.3.1.1.1. **Moderate.** Any areas that have a temperature differential greater than 25°F, but not exceeding 50°F, are deemed as having moderate thermal segregation.
- 4.7.3.1.1.2. **Severe.** Any areas that have a temperature differential greater than 50°F are deemed as having severe thermal segregation.
- 4.7.3.1.2. **Thermal Imaging System.** Review the output results when a thermal imaging system is used, and provide the automated report described in Tex-244-F to the Engineer daily unless otherwise directed. Modify the paving process as necessary to eliminate any recurring (moderate or severe) thermal segregation identified by the thermal imaging system. The Engineer may suspend paving operations if the Contractor cannot successfully modify the paving process to eliminate recurring severe thermal segregation. Provide the Engineer with electronic copies of all daily data files that can be used with the thermal imaging system software to generate temperature profile plots upon completion of the project or as requested by the Engineer.
- 4.7.3.1.3. **Thermal Camera.** Take immediate corrective action to eliminate recurring moderate thermal segregation when a hand-held thermal camera is used. Provide the Engineer with the thermal profile of every subplot within one working day of the completion of each lot. Report the results of each thermal profile in accordance with Section 342.4.2., "Reporting and Responsibilities." The Engineer will use a hand-held thermal camera to obtain a thermal profile at least once per project. Suspend operations and take immediate corrective action to eliminate severe thermal segregation unless otherwise directed. Resume operations when the Engineer determines that subsequent production will meet the requirements of this Section.
- 4.7.3.2. **Windrow Operations.** Operate windrow pickup equipment so that when hot-mix is placed in windrows, substantially all the mixture deposited on the roadbed is picked up and loaded into the paver.
- 4.7.3.3. **Hauling Equipment.** Use belly dumps, live bottom, or end dump trucks to haul and transfer mixture; however, with exception of paving miscellaneous areas, end dump trucks are only allowed when used in conjunction with an MTD with remixing capability or when a thermal imaging system is used unless otherwise allowed.
- 4.7.3.4. **Screed Heaters.** Turn off screed heaters to prevent overheating of the mat if the paver stops for more than 5 min. The Engineer may evaluate the suspect area in accordance with Section 342.4.9.5., "Recovered Asphalt Dynamic Shear Rheometer (DSR)," if the screed heater remains on for more than 5 min. while the paver is stopped.

- 4.8. **Compaction.** Roll the freshly placed PFC with a steel-wheeled roller, operated in static mode, to seat the mixture without excessive breakage of the aggregate and to provide a smooth surface and uniform texture. Do not use pneumatic rollers. Moisten the roller drums thoroughly with a soap and water solution to prevent adhesion. Use only water or an approved release agent on rollers, tamps, and other compaction equipment unless otherwise directed.
- The Engineer may use or require the Contractor to use Tex-246-F to test and verify that the compacted mixture has adequate permeability. Adjust the mixture design or construction methods if the compacted mixture does not exhibit adequate permeability.
- Complete all compaction operations before the pavement temperature drops below 160°F unless otherwise allowed. The Engineer may allow compaction with a light finish roller operated in static mode for pavement temperatures below 160°F.
- Allow the compacted pavement to cool to 160°F or lower before opening to traffic unless otherwise directed. Sprinkle the finished mat with water or limewater, when directed, to expedite opening the roadway to traffic.
- 4.9. **Acceptance Plan.** Sample and test the hot-mix on a lot and subplot basis. A production lot consists of 4 equal sublots. Lot 1 will be 2,000 tons. The Engineer will select subsequent lot sizes based on the anticipated daily production. The lot size will be between 2,000 and 4,000 tons. The Engineer may change the lot size before the Contractor begins any lot.
- 4.9.1. **Referee Testing.** The Construction Division is the referee laboratory. The Contractor may request referee testing if the differences between Contractor and Engineer test results exceed the operational tolerances shown in Table 5 and the differences cannot be resolved. The Contractor may also request referee testing if the Engineer's test results require suspension of production and the Contractor's test results are within specification limits. Make the request within 5 working days after receiving test results and cores from the Engineer. Referee tests will be performed only on the subplot in question and only for the particular tests in question. Allow 10 working days from the time the referee laboratory receives the samples for test results to be reported. The Department may require the Contractor to reimburse the Department for referee tests if more than 3 referee tests per project are required and the Engineer's test results are closer to the referee test results than the Contractor's test results.
- 4.9.2. **Asphalt Binder Sampling.** Obtain a 1 qt. (1 gal. for A-R binder) sample of the asphalt binder for each lot of mixture produced. Obtain the sample at approximately the same time the mixture random sample is obtained. Sample from a port located immediately upstream from the mixing drum or pug mill in accordance with Tex-500-C, Part II. Label the can with the corresponding lot and subplot numbers and deliver the sample to the Engineer. The Engineer may also obtain independent samples. If obtaining an independent asphalt binder sample, the Engineer will split a sample of the asphalt binder with the Contractor. The Engineer will test at least one asphalt binder sample per project to verify compliance with Item 300, "Asphalts, Oils, and Emulsions."
- 4.9.3. **Operational Tolerances.** Control the production process within the operational tolerances listed in Table 5. Suspend production and placement operations when production or placement test results exceed the tolerances listed in Table 5 unless otherwise allowed. When production is suspended, the Engineer will allow production to resume when test results or other information indicates the next mixture produced will be within the operational tolerances.
- 4.9.4. **Miscellaneous Areas.** Miscellaneous areas include areas that typically involve significant handwork or discontinuous paving operations such as driveways, mailbox turnouts, crossovers, gores, spot level-up areas, and other similar areas. The specified layer thickness is based on the rate of 90 lb./sq. yd. for each inch of pavement unless another rate is shown on the plans. Miscellaneous areas are not subject to thermal profiles testing.
- 4.9.5. **Recovered Asphalt Dynamic Shear Rheometer (DSR).** The Engineer may take production samples or cores from suspect areas of the project to determine recovered asphalt properties. Asphalt binders with an aging ratio greater than 3.5 do not meet the requirements for recovered asphalt properties and may be

deemed defective when tested and evaluated by the Construction Division. The aging ratio is the DSR value of the extracted binder divided by the DSR value of the original unaged binder. Obtain DSR values in accordance with AASHTO T 315 at the specified high temperature performance grade of the asphalt. The Engineer may require removal and replacement of the defective material at the Contractor's expense. The asphalt binder will be recovered for testing from production samples or cores in accordance with Tex-211-F.

- 4.9.6. **Irregularities.** Identify and correct irregularities, including segregation, rutting, raveling, flushing, fat spots, mat slippage, irregular color, irregular texture, roller marks, tears, gouges, streaks, uncoated aggregate particles, or broken aggregate particles. The Engineer may also identify irregularities, and in such cases, the Engineer will promptly notify the Contractor. If the Engineer determines that the irregularity will adversely affect pavement performance, the Engineer may require the Contractor to remove and replace (at the Contractor's expense) areas of the pavement that contain irregularities and areas where the mixture does not bond to the existing pavement. If irregularities are detected, the Engineer may require the Contractor to immediately suspend operations or may allow the Contractor to continue operations for no more than one day while the Contractor is taking appropriate corrective action.
- 4.9.7. **Ride Quality.** Measure ride quality in accordance with Item 585, "Ride Quality for Pavement Surfaces," unless otherwise shown on the plans.

5. MEASUREMENT

PFC will be measured by the ton of composite PFC. The composite PFC is defined as the asphalt, aggregate, and additives. The weights of asphalt and aggregate will be calculated based on the measured weight of PFC and the target percentage of asphalt and aggregate. Measure the weight on scales in accordance with Item 520, "Weighing and Measuring Equipment."

- 5.1. **Asphalt.** The asphalt weight in tons will be determined from the total weight of PFC. Measured asphalt percentage will be obtained using Tex-236-F or asphalt mass flow meter readings for PG 76 mixtures, as determined by the Engineer. Measured asphalt percentage will be obtained using asphalt mass flow meter readings for A-R mixtures. Provide the Engineer with a daily summary of the asphalt mass flow meter readings for A-R mixtures unless otherwise directed. Add the recycled binder content to the flow meter readings when calculating asphalt quantities.
- 5.1.1. **Target Percentage.** The JMF target asphalt percentage will be used to calculate the weight of asphalt binder unless the measured asphalt binder percentage is more than 0.3 percentage points below the JMF target asphalt percentage or less than the minimum percentage specified in Table 4. Volumetric meter readings will be adjusted to 140°F and converted to weight.
- 5.1.2. **Measured Percentage.** The averaged measured asphalt percentage from each subplot will be used for payment for that lot's production when the measured percentage for any subplot is more than 0.3 percentage points below the JMF target asphalt percentage or less than the minimum percentage specified in Table 4.
- 5.2. **Aggregate.** The aggregate weight in tons will be determined from the total weight of PFC less the weight of the asphalt.

6. PAYMENT

The work performed and materials furnished in accordance with this Item and measured as provided under Article 342.5., "Measurement," will be paid for at the unit bid price for "PFC (Asphalt)" of the binder specified and for "PFC (Aggregate)" of the grade and SAC specified. These prices are full compensation for surface preparation, materials including tack coat, placement, equipment, labor, tools, and incidentals.

Trial batches will not be paid for unless they are included in pavement work approved by the Department.

Payment adjustment for ride quality will be determined in accordance with Item 585, "Ride Quality for Pavement Surfaces."

Item 344

Superpave Mixtures



1. DESCRIPTION

Construct a hot-mix asphalt (HMA) pavement layer composed of a compacted, Superpave (SP) mixture of aggregate and asphalt binder mixed hot in a mixing plant. Payment adjustments will apply to HMA placed under this specification unless the HMA is deemed exempt in accordance with Section 344.4.9.4., "Exempt Production."

2. MATERIALS

Furnish uncontaminated materials of uniform quality that meet the requirements of the plans and specifications.

Notify the Engineer of all material sources and before changing any material source or formulation. The Engineer will verify that the specification requirements are met when the Contractor makes a source or formulation change and may require a new laboratory mixture design, trial batch, or both. The Engineer may sample and test project materials at any time during the project to verify specification compliance in accordance with Item 6, "Control of Materials."

- 2.1. **Aggregate.** Furnish aggregates from sources that conform to the requirements shown in Table 1 and as specified in this Section. Aggregate requirements in this Section, including those shown in Table 1, may be modified or eliminated when shown on the plans. Additional aggregate requirements may be specified when shown on the plans. Provide aggregate stockpiles that meet the definitions in this Section for coarse, intermediate, or fine aggregate. Aggregate from reclaimed asphalt pavement (RAP) is not required to meet Table 1 requirements unless otherwise shown on the plans. Supply aggregates that meet the definitions in Tex-100-E for crushed gravel or crushed stone. The Engineer will designate the plant or the quarry as the sampling location. Provide samples from materials produced for the project. The Engineer will establish the Surface Aggregate Classification (SAC) and perform Los Angeles abrasion, magnesium sulfate soundness, and Micro-Deval tests. Perform all other aggregate quality tests listed in Table 1. Document all test results on the mixture design report. The Engineer may perform tests on independent or split samples to verify Contractor test results. Stockpile aggregates for each source and type separately. Determine aggregate gradations for mixture design and production testing based on the washed sieve analysis given in Tex-200-F, Part II.

- 2.1.1. **Coarse Aggregate.** Coarse aggregate stockpiles must have no more than 20% material passing the No. 8 sieve. Aggregates from sources listed in the Department's *Bituminous Rated Source Quality Catalog* (BRSQC) are preapproved for use. Use only the rated values for hot-mix listed in the BRSQC. Rated values for surface treatment (ST) do not apply to coarse aggregate sources used in hot-mix asphalt.

For sources not listed on the Department's BRSQC:

- build an individual stockpile for each material;
- request the Department test the stockpile for specification compliance; and
- once approved, do not add material to the stockpile unless otherwise approved.

Provide aggregate from non-listed sources only when tested by the Engineer and approved before use. Allow 30 calendar days for the Engineer to sample, test, and report results for non-listed sources.

Provide coarse aggregate with at least the minimum SAC shown on the plans. SAC requirements only apply to aggregates used on the surface of travel lanes. SAC requirements apply to aggregates used on surfaces

other than travel lanes when shown on the plans. The SAC for sources on the Department's *Aggregate Quality Monitoring Program (AQMP) (Tex-499-A)* is listed in the BRSQC.

- 2.1.1.1. **Blending Class A and Class B Aggregates.** Class B aggregate meeting all other requirements in Table 1 may be blended with a Class A aggregate to meet requirements for Class A materials. Ensure that at least 50% by weight, or volume if required, of the material retained on the No. 4 sieve comes from the Class A aggregate source when blending Class A and B aggregates to meet a Class A requirement. Blend by volume if the bulk specific gravities of the Class A and B aggregates differ by more than 0.300. Coarse aggregate from RAP and Recycled Asphalt Shingles (RAS) will be considered as Class B aggregate for blending purposes.

The Engineer may perform tests at any time during production, when the Contractor blends Class A and B aggregates to meet a Class A requirement, to ensure that at least 50% by weight, or volume if required, of the material retained on the No. 4 sieve comes from the Class A aggregate source. The Engineer will use the Department's mix design template, when electing to verify conformance, to calculate the percent of Class A aggregate retained on the No. 4 sieve by inputting the bin percentages shown from readouts in the control room at the time of production and stockpile gradations measured at the time of production. The Engineer may determine the gradations based on either washed or dry sieve analysis from samples obtained from individual aggregate cold feed bins or aggregate stockpiles. The Engineer may perform spot checks using the gradations supplied by the Contractor on the mixture design report as an input for the template; however, a failing spot check will require confirmation with a stockpile gradation determined by the Engineer.

- 2.1.1.2. **Micro-Deval Abrasion.** The Engineer will perform a minimum of one Micro-Deval abrasion test in accordance with Tex-461-A for each coarse aggregate source used in the mixture design that has a Rated Source Soundness Magnesium (RSSM) loss value greater than 15 as listed in the BRSQC. The Engineer will perform testing before the start of production and may perform additional testing at any time during production. The Engineer may obtain the coarse aggregate samples from each coarse aggregate source or may require the Contractor to obtain the samples. The Engineer may waive all Micro-Deval testing based on a satisfactory test history of the same aggregate source.

The Engineer will estimate the magnesium sulfate soundness loss for each coarse aggregate source, when tested, using the following formula:

$$Mg_{est.} = (RSSM)(MD_{act.}/RSMD)$$

where:

$Mg_{est.}$ = magnesium sulfate soundness loss

$MD_{act.}$ = actual Micro-Deval percent loss

$RSMD$ = Rated Source Micro-Deval

When the estimated magnesium sulfate soundness loss is greater than the maximum magnesium sulfate soundness loss specified, the coarse aggregate source will not be allowed for use unless otherwise approved. The Engineer will consult the Geotechnical, Soils, and Aggregates Branch of the Construction Division, and additional testing may be required before granting approval.

- 2.1.2. **Intermediate Aggregate.** Aggregates not meeting the definition of coarse or fine aggregate will be defined as intermediate aggregate. Supply intermediate aggregates, when used that are free from organic impurities. The Engineer may test the intermediate aggregate in accordance with Tex-408-A to verify the material is free from organic impurities. Supply intermediate aggregate from coarse aggregate sources, when used that meet the requirements shown in Table 1 unless otherwise approved.

Test the stockpile if 10% or more of the stockpile is retained on the No. 4 sieve, and verify that it meets the requirements in Table 1 for crushed face count (Tex-460-A) and flat and elongated particles (Tex-280-F).

- 2.1.3. **Fine Aggregate.** Fine aggregates consist of manufactured sands, screenings, and field sands. Fine aggregate stockpiles must meet the gradation requirements in Table 2. Supply fine aggregates that are free from organic impurities. The Engineer may test the fine aggregate in accordance with Tex-408-A to verify the

material is free from organic impurities. No more than 15% of the total aggregate may be field sand or other uncrushed fine aggregate. Use fine aggregate, with the exception of field sand, from coarse aggregate sources that meet the requirements shown in Table 1 unless otherwise approved.

Test the stockpile if 10% or more of the stockpile is retained on the No. 4 sieve and verify that it meets the requirements in Table 1 for crushed face count (Tex-460-A) and flat and elongated particles (Tex-280-F).

Table 1
Aggregate Quality Requirements

Property	Test Method	Requirement
Coarse Aggregate		
SAC	Tex-499-A (AQMP)	As shown on the plans
Deleterious material, %, Max	Tex-217-F, Part I	1.0
Decantation, %, Max	Tex-217-F, Part II	1.5
Micro-Deval abrasion, %	Tex-461-A	Note ¹
Los Angeles abrasion, %, Max	Tex-410-A	35
Magnesium sulfate soundness, 5 cycles, %, Max	Tex-411-A	25
Crushed face count, ² %, Min	Tex-460-A, Part I	85
Flat and elongated particles @ 5:1, %, Max	Tex-280-F	10
Fine Aggregate		
Linear shrinkage, %, Max	Tex-107-E	3
Combined Aggregate³		
Sand equivalent, %, Min	Tex-203-F	45

1. Used to estimate the magnesium sulfate soundness loss in accordance with Section 344.2.1.1.2., "Micro-Deval Abrasion."
2. Only applies to crushed gravel.
3. Aggregates, without mineral filler, RAP, RAS, or additives, combined as used in the job-mix formula (JMF).

Table 2
Gradation Requirements for Fine Aggregate

Sieve Size	% Passing by Weight or Volume
3/8"	100
#8	70–100
#200	0–30

- 2.2. **Mineral Filler.** Mineral filler consists of finely divided mineral matter such as agricultural lime, crusher fines, hydrated lime, or fly ash. Mineral filler is allowed unless otherwise shown on the plans. Use no more than 2% hydrated lime or fly ash unless otherwise shown on the plans. Use no more than 1% hydrated lime if a substitute binder is used unless otherwise shown on the plans or allowed. Test all mineral fillers except hydrated lime and fly ash in accordance with Tex-107-E to ensure specification compliance. The plans may require or disallow specific mineral fillers. Provide mineral filler, when used, that:
- is sufficiently dry, free-flowing, and free from clumps and foreign matter as determined by the Engineer;
 - does not exceed 3% linear shrinkage when tested in accordance with Tex-107-E; and
 - meets the gradation requirements in Table 3.

Table 3
Gradation Requirements for Mineral Filler

Sieve Size	% Passing by Weight or Volume
#8	100
#200	55–100

- 2.3. **Baghouse Fines.** Fines collected by the baghouse or other dust-collecting equipment may be reintroduced into the mixing drum.
- 2.4. **Asphalt Binder.** Furnish the type and grade of performance-graded (PG) asphalt specified on the plans.
- 2.5. **Tack Coat.** Furnish CSS-1H, SS-1H, or a PG binder with a minimum high-temperature grade of PG 58 for tack coat binder in accordance with Item 300, "Asphalts, Oils, and Emulsions." Specialized or preferred tack coat materials may be allowed or required when shown on the plans. Do not dilute emulsified asphalts at the terminal, in the field, or at any other location before use.

The Engineer will obtain at least one sample of the tack coat binder per project in accordance with Tex-500-C, Part III, and test it to verify compliance with Item 300, "Asphalts, Oils, and Emulsions." The Engineer will obtain the sample from the asphalt distributor immediately before use.

- 2.6. **Additives.** Use the type and rate of additive specified when shown on the plans. Additives that facilitate mixing, compaction, or improve the quality of the mixture are allowed when approved. Provide the Engineer with documentation such as the bill of lading showing the quantity of additives used in the project unless otherwise directed.
- 2.6.1. **Lime and Liquid Antistripping Agent.** When lime or a liquid antistripping agent is used, add in accordance with Item 301, "Asphalt Antistripping Agents." Do not add lime directly into the mixing drum of any plant where lime is removed through the exhaust stream unless the plant has a baghouse or dust collection system that reintroduces the lime into the drum.
- 2.6.2. **Warm Mix Asphalt (WMA).** Warm Mix Asphalt (WMA) is defined as HMA that is produced within a target temperature discharge range of 215°F and 275°F using approved WMA additives or processes from the Department's MPL.

WMA is allowed for use on all projects and is required when shown on the plans. When WMA is required, the maximum placement or target discharge temperature for WMA will be set at a value below 275°F.

Department-approved WMA additives or processes may be used to facilitate mixing and compaction of HMA produced at target discharge temperatures above 275°F; however, such mixtures will not be defined as WMA.

- 2.7. **Recycled Materials.** Use of RAP and RAS is permitted unless otherwise shown on the plans. Do not exceed the maximum allowable percentages of RAP and RAS shown in Table 4. The allowable percentages shown in Table 4 may be decreased or increased when shown on the plans. Determine asphalt binder content and gradation of the RAP and RAS stockpiles for mixture design purposes in accordance with Tex-236-F. The Engineer may verify the asphalt binder content of the stockpiles at any time during production. Perform other tests on RAP and RAS when shown on the plans. Asphalt binder from RAP and RAS is designated as recycled asphalt binder. Calculate and ensure that the ratio of the recycled asphalt binder to total binder does not exceed the percentages shown in Table 5 during mixture design and HMA production when RAP or RAS is used. Use a separate cold feed bin for each stockpile of RAP and RAS during HMA production.

Surface, intermediate, and base mixes referenced in Tables 4 and 5 are defined as follows:

- **Surface.** The final HMA lift placed at or near the top of the pavement structure;
- **Intermediate.** Mixtures placed below an HMA surface mix and less than or equal to 8.0 in. from the riding surface; and
- **Base.** Mixtures placed greater than 8.0 in. from the riding surface.

- 2.7.1. **RAP.** RAP is salvaged, milled, pulverized, broken, or crushed asphalt pavement. Crush or break RAP so that 100% of the particles pass the 2 in. sieve. Fractionated RAP is defined as 2 or more RAP stockpiles, divided into coarse and fine fractions.

Use of Contractor-owned RAP including HMA plant waste is permitted unless otherwise shown on the plans. Department-owned RAP stockpiles are available for the Contractor's use when the stockpile locations are shown on the plans. If Department-owned RAP is available for the Contractor's use, the Contractor may use Contractor-owned fractionated RAP and replace it with an equal quantity of Department-owned RAP. This allowance does not apply to a Contractor using unfractionated RAP. Department-owned RAP generated through required work on the Contract is available for the Contractor's use when shown on the plans. Perform any necessary tests to ensure Contractor- or Department-owned RAP is appropriate for use. The Department will not perform any tests or assume any liability for the quality of the Department-owned RAP unless otherwise shown on the plans. The Contractor will retain ownership of RAP generated on the project when shown on the plans.

The coarse RAP stockpile will contain only material retained by processing over a 3/8-in. or 1/2-in. screen unless otherwise approved. The fine RAP stockpile will contain only material passing the 3/8-in. or 1/2-in. screen unless otherwise approved. The Engineer may allow the Contractor to use an alternate to the 3/8-in. or 1/2-in. screen to fractionate the RAP. The maximum percentages of fractionated RAP may be comprised of coarse or fine fractionated RAP or the combination of both coarse and fine fractionated RAP.

Do not use Department- or Contractor-owned RAP contaminated with dirt or other objectionable materials. Do not use Department- or Contractor-owned RAP if the decantation value exceeds 5% and the plasticity index is greater than 8. Test the stockpiled RAP for decantation in accordance with Tex-406-A, Part I. Determine the plasticity index in accordance with Tex-106-E if the decantation value exceeds 5%. The decantation and plasticity index requirements do not apply to RAP samples with asphalt removed by extraction or ignition.

Do not intermingle Contractor-owned RAP stockpiles with Department-owned RAP stockpiles. Remove unused Contractor-owned RAP material from the project site upon completion of the project. Return unused Department-owned RAP to the designated stockpile location.

Table 4
Maximum Allowable Amounts of RAP¹

Maximum Allowable Fractionated RAP ² (%)			Maximum Allowable Unfractionated RAP ³ (%)		
Surface	Intermediate	Base	Surface	Intermediate	Base
20.0	25.0	30.0	10.0	10.0	10.0

1. Must also meet the recycled binder to total binder ratio shown in Table 5.
2. Up to 5% RAS may be used separately or as a replacement for fractionated RAP.
3. Unfractionated RAP may not be combined with fractionated RAP or RAS.

2.7.2.

RAS. Use of post-manufactured RAS or post-consumer RAS (tear-offs) is permitted unless otherwise shown on the plans. Up to 5% RAS may be used separately or as a replacement for fractionated RAP in accordance with Table 4 and Table 5. RAS is defined as processed asphalt shingle material from manufacturing of asphalt roofing shingles or from re-roofing residential structures. Post-manufactured RAS is processed manufacturer's shingle scrap by-product. Post-consumer RAS is processed shingle scrap removed from residential structures. Comply with all regulatory requirements stipulated for RAS by the TCEQ. RAS may be used separately or in conjunction with RAP.

Process the RAS by ambient grinding or granulating such that 100% of the particles pass the 3/8 in. sieve when tested in accordance with Tex-200-F, Part I. Perform a sieve analysis on processed RAS material before extraction (or ignition) of the asphalt binder.

Add sand meeting the requirements of Table 1 and Table 2 or fine RAP to RAS stockpiles if needed to keep the processed material workable. Any stockpile that contains RAS will be considered a RAS stockpile and be limited to no more than 5.0% of the HMA mixture in accordance with Table 4.

Certify compliance of the RAS with DMS-11000, "Evaluating and Using Nonhazardous Recyclable Materials Guidelines." Treat RAS as an established nonhazardous recyclable material if it has not come into contact with any hazardous materials. Use RAS from shingle sources on the Department's MPL. Remove substantially all materials before use that are not part of the shingle, such as wood, paper, metal, plastic, and felt paper. Determine the deleterious content of RAS material for mixture design purposes in accordance with Tex-217-F, Part III. Do not use RAS if deleterious materials are more than 0.5% of the stockpiled RAS unless otherwise approved. Submit a sample for approval before submitting the mixture design. The Department will perform the testing for deleterious material of RAS to determine specification compliance.

2.8.

Substitute Binders. Unless otherwise shown on the plans, the Contractor may use a substitute PG binder listed in Table 5 instead of the PG binder originally specified, if the substitute PG binder and mixture made with the substitute PG binder meet the following:

- the substitute binder meets the specification requirements for the substitute binder grade in accordance with Section 300.2.10., "Performance-Graded Binders;" and

- the mixture has less than 10.0 mm of rutting on the Hamburg Wheel test (Tex-242-F) after the number of passes required for the originally specified binder. Use of substitute PG binders may only be allowed at the discretion of the Engineer if the Hamburg Wheel test results are between 10.0 mm and 12.5 mm.

Table 5
Allowable Substitute PG Binders and Maximum Recycled Binder Ratios

Originally Specified PG Binder	Allowable Substitute PG Binder	Maximum Ratio of Recycled Binder ¹ to Total Binder (%)		
		Surface	Intermediate	Base
HMA				
76-22 ²	70-22 or 64-22	20.0	20.0	20.0
	70-28 or 64-28	30.0	35.0	40.0
70-22 ²	64-22	20.0	20.0	20.0
	64-28 or 58-28	30.0	35.0	40.0
64-22 ²	58-28	30.0	35.0	40.0
76-28 ²	70-28 or 64-28	20.0	20.0	20.0
	64-34	30.0	35.0	40.0
70-28 ²	64-28 or 58-28	20.0	20.0	20.0
	64-34 or 58-34	30.0	35.0	40.0
64-28 ²	58-28	20.0	20.0	20.0
	58-34	30.0	35.0	40.0
WMA³				
76-22 ²	70-22 or 64-22	30.0	35.0	40.0
70-22 ²	64-22 or 58-28	30.0	35.0	40.0
64-22 ⁴	58-28	30.0	35.0	40.0
76-28 ²	70-28 or 64-28	30.0	35.0	40.0
70-28 ²	64-28 or 58-28	30.0	35.0	40.0
64-28 ⁴	58-28	30.0	35.0	40.0

- Combined recycled binder from RAP and RAS.
- Use no more than 20.0% recycled binder when using this originally specified PG binder.
- WMA as defined in Section 344.2.6.2., "Warm Mix Asphalt (WMA)."
- When used with WMA, this originally specified PG binder is allowed for use at the maximum recycled binder ratios shown in this table.

3. EQUIPMENT

Provide required or necessary equipment in accordance with Item 320, "Equipment for Asphalt Concrete Pavement."

4. CONSTRUCTION

Produce, haul, place, and compact the specified paving mixture. In addition to tests required by the specification, Contractors may perform other QC tests as deemed necessary. At any time during the project, the Engineer may perform production and placement tests as deemed necessary in accordance with Item 5, "Control of the Work." Schedule and participate in a mandatory pre-paving meeting with the Engineer on or before the first day of paving unless otherwise shown on the plans.

- Certification.** Personnel certified by the Department-approved hot-mix asphalt certification program must conduct all mixture designs, sampling, and testing in accordance with Table 6. Supply the Engineer with a list of certified personnel and copies of their current certificates before beginning production and when personnel changes are made. Provide a mixture design developed and signed by a Level 2 certified specialist. Provide Level 1A certified specialists at the plant during production operations. Provide Level 1B certified specialists to conduct placement tests.

Table 6
Test Methods, Test Responsibility, and Minimum Certification Levels

Test Description	Test Method	Contractor	Engineer	Level ¹
1. Aggregate and Recycled Material Testing				
Sampling	Tex-221-F	✓	✓	1A
Dry sieve	Tex-200-F, Part I	✓	✓	1A
Washed sieve	Tex-200-F, Part II	✓	✓	1A
Deleterious material	Tex-217-F, Parts I & III	✓	✓	1A
Decantation	Tex-217-F, Part II	✓	✓	1A
Los Angeles abrasion	Tex-410-A		✓	TxDOT
Magnesium sulfate soundness	Tex-411-A		✓	TxDOT
Micro-Deval abrasion	Tex-461-A		✓	2
Crushed face count	Tex-460-A	✓	✓	2
Flat and elongated particles	Tex-280-F	✓	✓	2
Linear shrinkage	Tex-107-E	✓	✓	2
Sand equivalent	Tex-203-F	✓	✓	2
Organic impurities	Tex-408-A	✓	✓	2
2. Asphalt Binder & Tack Coat Sampling				
Asphalt binder sampling	Tex-500-C, Part II	✓	✓	1A/1B
Tack coat sampling	Tex-500-C, Part III	✓	✓	1A/1B
3. Mix Design & Verification				
Design and JMF changes	Tex-204-F	✓	✓	2
Mixing	Tex-205-F	✓	✓	2
Molding (SGC)	Tex-241-F	✓	✓	1A
Laboratory-molded density	Tex-207-F	✓	✓	1A
VMA ² (calculation only)	Tex-204-F	✓	✓	2
Rice gravity	Tex-227-F	✓	✓	1A
Ignition oven correction factors ³	Tex-236-F	✓	✓	2
Indirect tensile strength	Tex-226-F	✓	✓	2
Hamburg Wheel test	Tex-242-F	✓	✓	2
Boil test	Tex-530-C	✓	✓	1A
4. Production Testing				
Selecting production random numbers	Tex-225-F, Part I		✓	1A
Mixture sampling	Tex-222-F	✓	✓	1A
Molding (SGC)	Tex-241-F	✓	✓	1A
Laboratory-molded density	Tex-207-F	✓	✓	1A
VMA ² (calculation only)	Tex-204-F	✓	✓	1A
Rice gravity	Tex-227-F	✓	✓	1A
Gradation & asphalt binder content ³	Tex-236-F	✓	✓	1A
Control charts	Tex-233-F	✓	✓	1A
Moisture content	Tex-212-F	✓	✓	1A
Hamburg Wheel test	Tex-242-F	✓	✓	2
Micro-Deval abrasion	Tex-461-A		✓	2
Boil test	Tex-530-C	✓	✓	1A
Abson recovery	Tex-211-F		✓	TxDOT
Overlay test	Tex-248-F		✓	TxDOT
Cantabro loss	Tex-245-F		✓	2
5. Placement Testing				
Selecting placement random numbers	Tex-225-F, Part II		✓	1A/1B
Trimming roadway cores	Tex-207-F	✓	✓	1A/1B
In-place air voids	Tex-207-F	✓	✓	1A/1B
Establish rolling pattern	Tex-207-F	✓		1B
Control charts	Tex-233-F	✓	✓	1A
Ride quality measurement	Tex-1001-S	✓	✓	Note ⁴
Segregation (density profile)	Tex-207-F, Part V	✓	✓	1B
Longitudinal joint density	Tex-207-F, Part VII	✓	✓	1B
Thermal profile	Tex-244-F	✓	✓	1B

1. Level 1A, 1B, and 2 are certification levels provided by the Hot Mix Asphalt Center certification program.
2. Voids in mineral aggregates.
3. Refer to Section 344.4.9.2.3., "Production Testing," for exceptions to using an ignition oven.
4. Profiler and operator are required to be certified at the Texas A&M Transportation Institute facility when Surface Test Type B is specified.

4.2.

Reporting and Responsibilities. Use Department-provided templates to record and calculate all test data, including mixture design, production and placement QC/QA, control charts, thermal profiles, segregation density profiles, and longitudinal joint density. Obtain the current version of the templates at <http://www.txdot.gov/inside-txdot/forms-publications/consultants-contractors/forms/site-manager.html> or from the Engineer. The Engineer and the Contractor will provide any available test results to the other party when requested. The maximum allowable time for the Contractor and Engineer to exchange test data is as given in Table 7 unless otherwise approved. The Engineer and the Contractor will immediately report to the other party any test result that requires suspension of production or placement, a payment adjustment less than 1,000, or that fails to meet the specification requirements. Record and electronically submit all test results and pertinent information on Department-provided templates.

Subsequent sublots placed after test results are available to the Contractor, which require suspension of operations, may be considered unauthorized work. Unauthorized work will be accepted or rejected at the discretion of the Engineer in accordance with Article 5.3., "Conformity with Plans, Specifications, and Special Provisions."

Table 7
Reporting Schedule

Description	Reported By	Reported To	To Be Reported Within
Production Quality Control			
Gradation ¹	Contractor	Engineer	1 working day of completion of the subplot
Asphalt binder content ¹			
Laboratory-molded density ²			
Moisture content ³			
Boil test ³			
Production Quality Assurance			
Gradation ³	Engineer	Contractor	1 working day of completion of the subplot
Asphalt binder content ³			
Laboratory-molded density ¹			
Hamburg Wheel test ²			
Boil test ³			
Binder tests ²			
Placement Quality Control			
In-place air voids ²	Contractor	Engineer	1 working day of completion of the lot
Segregation ¹			
Longitudinal joint density ¹			
Thermal profile ¹			
Placement Quality Assurance			
In-place air voids ¹	Engineer	Contractor	1 working day of receipt of the trimmed cores for in-place air voids ⁴
Segregation ²			
Longitudinal joint density ²			
Thermal profile ²			
Aging ratio ²			
Payment adjustment summary	Engineer	Contractor	2 working days of performing all required tests and receiving Contractor test data

1. These tests are required on every subplot.
2. Optional test. To be reported as soon as results become available.
3. To be performed at the frequency specified on the plans.
4. 2 days are allowed if cores cannot be dried to constant weight within 1 day.

The Engineer will use the Department-provided template to calculate all payment adjustment factors for the lot. Sublot samples may be discarded after the Engineer and Contractor sign off on the payment adjustment summary documentation for the lot.

Use the procedures described in Tex-233-F to plot the results of all quality control (QC) and quality assurance (QA) testing. Update the control charts as soon as test results for each subplot become available. Make the control charts readily accessible at the field laboratory. The Engineer may suspend production for failure to update control charts.

- 4.3. **Quality Control Plan (QCP).** Develop and follow the QCP in detail. Obtain approval for changes to the QCP made during the project. The Engineer may suspend operations if the Contractor fails to comply with the QCP.
- Submit a written QCP before the mandatory pre-paving meeting. Receive approval of the QCP before beginning production. Include the following items in the QCP:
- 4.3.1. **Project Personnel.** For project personnel, include:
- a list of individuals responsible for QC with authority to take corrective action;
 - current contact information for each individual listed; and
 - current copies of certification documents for individuals performing specified QC functions.
- 4.3.2. **Material Delivery and Storage.** For material delivery and storage, include:
- the sequence of material processing, delivery, and minimum quantities to assure continuous plant operations;
 - aggregate stockpiling procedures to avoid contamination and segregation;
 - frequency, type, and timing of aggregate stockpile testing to assure conformance of material requirements before mixture production; and
 - procedure for monitoring the quality and variability of asphalt binder.
- 4.3.3. **Production.** For production, include:
- loader operation procedures to avoid contamination in cold bins;
 - procedures for calibrating and controlling cold feeds;
 - procedures to eliminate debris or oversized material;
 - procedures for adding and verifying rates of each applicable mixture component (e.g., aggregate, asphalt binder, RAP, RAS, lime, liquid antistripping, WMA);
 - procedures for reporting job control test results; and
 - procedures to avoid segregation and drain-down in the silo.
- 4.3.4. **Loading and Transporting.** For loading and transporting, include:
- type and application method for release agents; and
 - truck loading procedures to avoid segregation.
- 4.3.5. **Placement and Compaction.** For placement and compaction, include:
- proposed agenda for mandatory pre-paving meeting, including date and location;
 - proposed paving plan (e.g., paving widths, joint offsets, and lift thicknesses);
 - type and application method for release agents in the paver and on rollers, shovels, lutes, and other utensils;
 - procedures for the transfer of mixture into the paver, while avoiding segregation and preventing material spillage;
 - process to balance production, delivery, paving, and compaction to achieve continuous placement operations and good ride quality;
 - paver operations (e.g., operation of wings, height of mixture in auger chamber) to avoid physical and thermal segregation and other surface irregularities; and
 - procedures to construct quality longitudinal and transverse joints.
- 4.4. **Mixture Design.**
- 4.4.1. **Design Requirements.** Use the SP design procedure provided in Tex-204-F, unless otherwise shown on the plans. Design the mixture to meet the requirements listed in Tables 1, 2, 3, 4, 5, 8, 9, 10, and 11.

Design the mixture at 50 gyrations (N_{design}). Use a target laboratory-molded density of 96.0% to design the mixture; however, adjustments can be made to the N_{design} value as noted in Table 10. The N_{design} level may be reduced to no less than 35 gyrations at the Contractor's discretion.

Use an approved laboratory from the Department's MPL to perform the Hamburg Wheel test and provide results with the mixture design, or provide the laboratory mixture and request that the Department perform the Hamburg Wheel test. The Engineer will be allowed 10 working days to provide the Contractor with Hamburg Wheel test results on the laboratory mixture design.

The Engineer will provide the mixture design when shown on the plans. The Contractor may submit a new mixture design at any time during the project. The Engineer will verify and approve all mixture designs (JMF1) before the Contractor can begin production.

The aggregate gradation may pass above, below, or through the reference zone shown in Table 9 unless otherwise shown on the plans. Design a mixture with a gradation that has stone-on-stone contact and passes below the reference zone shown in Table 9 when shown on the plans. Verify stone-on-stone contact using the method given in the SP design procedure in Tex-204-F, Part IV.

Provide the Engineer with a mixture design report using the Department-provided template. Include the following items in the report:

- the combined aggregate gradation, source, specific gravity, and percent of each material used;
- asphalt binder content and aggregate gradation of RAP and RAS stockpiles;
- the N_{design} level used;
- results of all applicable tests;
- the mixing and molding temperatures;
- the signature of the Level 2 person or persons that performed the design;
- the date the mixture design was performed; and
- a unique identification number for the mixture design.

Table 8
Master Gradation Limits (% Passing by Weight or Volume) and VMA Requirements

Sieve Size	SP-A Base	SP-B Intermediate	SP-C Surface	SP-D Fine Mixture
2"	100.0 ¹	–	–	–
1-1/2"	98.0–100.0	100.0 ¹	–	–
1"	90.0–100.0	98.0–100.0	100.0 ¹	–
3/4"	Note ²	90.0–100.0	98.0–100.0	100.0 ¹
1/2"	–	Note ²	90.0–100.0	98.0–100.0
3/8"	–	–	Note ²	90.0–100.0
#4	19.0–90.0	23.0–90.0	28.0–90.0	32.0–90.0
#8	19.0–45.0	23.0–49.0	28.0–58.0	32.0–67.0
#16	1.0–45.0	2.0–49.0	2.0–58.0	2.0–67.0
#30	1.0–45.0	2.0–49.0	2.0–58.0	2.0–67.0
#50	1.0–45.0	2.0–49.0	2.0–58.0	2.0–67.0
#200	1.0–7.0	2.0–8.0	2.0–10.0	2.0–10.0
Design VMA, % Minimum				
	13.0	14.0	15.0	16.0
Production (Plant-Produced) VMA, % Minimum				
	12.5	13.5	14.5	15.5

1. Defined as maximum sieve size. No tolerance allowed.
2. Must retain at least 10% cumulative.

Table 9
Reference Zones (% Passing by Weight or Volume)

Sieve Size	SP-A Base	SP-B Intermediate	SP-C Surface	SP-D Fine Mixture
2"	–	–	–	–
1-1/2"	–	–	–	–
1"	–	–	–	–
3/4"	–	–	–	–
1/2"	–	–	–	–
3/8"	–	–	–	–
#4	39.5–39.5	–	–	–
#8	26.8–30.8	34.6–34.6	39.1–39.1	47.2–47.2
#16	18.1–24.1	22.3–28.3	25.6–31.6	31.6–37.6
#30	13.6–17.5	16.7–20.7	19.1–23.1	23.5–27.5
#50	11.4–11.4	13.7–13.7	15.5–15.5	18.7–18.7
#200	–	–	–	–

Table 10
Laboratory Mixture Design Properties

Mixture Property	Test Method	Requirement
Target laboratory-molded density, %	Tex-207-F	96.0
Design gyrations (Ndesign)	Tex-241-F	50 ¹
Indirect tensile strength (dry), psi	Tex-226-F	85–200 ²
Dust/asphalt binder ratio ³	–	0.6–1.6
Boil test ⁴	Tex-530-C	–

1. Adjust within a range of 35–100 gyrations when shown on the plans or specification or mutually agreed between the Engineer and Contractor.
2. The Engineer may allow the IDT strength to exceed 200 psi if the corresponding Hamburg Wheel rut depth is greater than 3.0 mm and less than 12.5 mm.
3. Defined as % passing #200 sieve divided by asphalt binder content.
4. Used to establish baseline for comparison to production results. May be waived when approved.

Table 11
Hamburg Wheel Test Requirements

High-Temperature Binder Grade	Test Method	Minimum # of Passes @ 12.5 mm ¹ Rut Depth, Tested @ 50°C
PG 64 or lower	Tex-242-F	10,000 ²
PG 70		15,000 ³
PG 76 or higher		20,000

1. When the rut depth at the required minimum number of passes is less than 3 mm, the Engineer may require the Contractor to lower the Ndesign level to no less than 35 gyrations.
2. May be decreased to no less than 5,000 passes when shown on the plans.
3. May be decreased to no less than 10,000 passes when shown on the plans.

4.4.2. **Job-Mix Formula Approval.** The job-mix formula (JMF) is the combined aggregate gradation, Ndesign level, and target asphalt percentage used to establish target values for hot-mix production. JMF1 is the original laboratory mixture design used to produce the trial batch. When WMA is used, JMF1 may be designed and submitted to the Engineer without including the WMA additive. When WMA is used, document the additive or process used and recommended rate on the JMF1 submittal. The Engineer and the Contractor will verify JMF1 based on plant-produced mixture from the trial batch unless otherwise approved. The Engineer may accept an existing mixture design previously used on a Department project and may waive the trial batch to verify JMF1. The Department may require the Contractor to reimburse the Department for verification tests if more than 2 trial batches per design are required.

4.4.2.1. **Contractor's Responsibilities.**

4.4.2.1.1. **Providing Superpave Gyrotory Compactor (SGC).** Furnish an SGC calibrated in accordance with Tex-241-F for molding production samples. Locate the SGC at the Engineer's field laboratory and make the SGC available to the Engineer for use in molding production samples.

- 4.4.2.1.2. **Gyratory Compactor Correlation Factors.** Use Tex-206-F, Part II, to perform a gyratory compactor correlation when the Engineer uses a different SGC. Apply the correlation factor to all subsequent production test results.
- 4.4.2.1.3. **Submitting JMF1.** Furnish a mix design report (JMF1) with representative samples of all component materials and request approval to produce the trial batch. Provide approximately 10,000 g of the design mixture if opting to have the Department perform the Hamburg Wheel test on the laboratory mixture, and request that the Department perform the test.
- 4.4.2.1.4. **Supplying Aggregates.** Provide approximately 40 lb. of each aggregate stockpile unless otherwise directed.
- 4.4.2.1.5. **Supplying Asphalt.** Provide at least 1 gal. of the asphalt material and sufficient quantities of any additives proposed for use.
- 4.4.2.1.6. **Ignition Oven Correction Factors.** Determine the aggregate and asphalt correction factors from the ignition oven in accordance with Tex-236-F. Provide the Engineer with split samples of the mixtures before the trial batch production, including all additives (except water), and blank samples used to determine the correction factors for the ignition oven used for QA testing during production. Correction factors established from a previously approved mixture design may be used for the current mixture design if the mixture design and ignition oven are the same as previously used, unless otherwise directed.
- 4.4.2.1.7. **Boil Test.** Perform the test and retain the tested sample from Tex-530-C until completion of the project or as directed. Use this sample for comparison purposes during production. The Engineer may waive the requirement for the boil test.
- 4.4.2.1.8. **Trial Batch Production.** Provide a plant-produced trial batch upon receiving conditional approval of JMF1 and authorization to produce a trial batch, including the WMA additive or process if applicable, for verification testing of JMF1 and development of JMF2. Produce a trial batch mixture that meets the requirements in Table 4, Table 5, and Table 12. The Engineer may accept test results from recent production of the same mixture instead of a new trial batch.
- 4.4.2.1.9. **Trial Batch Production Equipment.** Use only equipment and materials proposed for use on the project to produce the trial batch.
- 4.4.2.1.10. **Trial Batch Quantity.** Produce enough quantity of the trial batch to ensure that the mixture meets the specification requirements.
- 4.4.2.1.11. **Number of Trial Batches.** Produce trial batches as necessary to obtain a mixture that meets the specification requirements.
- 4.4.2.1.12. **Trial Batch Sampling.** Obtain a representative sample of the trial batch and split it into 3 equal portions in accordance with Tex-222-F. Label these portions as "Contractor," "Engineer," and "Referee." Deliver samples to the appropriate laboratory as directed.
- 4.4.2.1.13. **Trial Batch Testing.** Test the trial batch to ensure the mixture produced using the proposed JMF1 meets the mixture requirements in Table 12. Ensure the trial batch mixture is also in compliance with the Hamburg Wheel-requirement in Table 11. Use a Department-approved laboratory to perform the Hamburg Wheel test on the trial batch mixture or request that the Department perform the Hamburg Wheel test.
- The Engineer will be allowed 10 working days to provide the Contractor with Hamburg Wheel test results on the trial batch. Provide the Engineer with a copy of the trial batch test results.
- 4.4.2.1.14. **Development of JMF2.** Evaluate the trial batch test results after the Engineer grants full approval of JMF1 based on results from the trial batch, determine the optimum mixture proportions, and submit as JMF2. Adjust the asphalt binder content or gradation to achieve the specified target laboratory-molded density. The asphalt binder content established for JMF2 is not required to be within any tolerance of the optimum asphalt

binder content established for JMF1; however, mixture produced using JMF2 must meet the voids in mineral aggregates (VMA) requirements for production shown in Table 8. If the optimum asphalt binder content for JMF2 is more than 0.5% lower than the optimum asphalt binder content for JMF1, the Engineer may perform or require the Contractor to perform Tex-226-F on Lot 1 production to confirm the indirect tensile strength does not exceed 200 psi. Verify that JMF2 meets the mixture requirements in Table 4 and Table 5.

- 4.4.2.1.15. **Mixture Production.** Use JMF2 to produce Lot 1 as described in Section 344.4.9.3.1.1., “Lot 1 Placement,” after receiving approval for JMF2 and a passing result from the Department’s or a Department-approved laboratory’s Hamburg Wheel test on the trial batch. If desired, proceed to Lot 1 production, once JMF2 is approved, at the Contractor’s risk without receiving the results from the Department’s Hamburg Wheel test on the trial batch.

Notify the Engineer if electing to proceed without Hamburg Wheel test results from the trial batch. Note that the Engineer may require up to the entire subplot of any mixture failing the Hamburg Wheel test to be removed and replaced at the Contractor’s expense.

- 4.4.2.1.16. **Development of JMF3.** Evaluate the test results from Lot 1, determine the optimum mixture proportions, and submit as JMF3 for use in Lot 2.

- 4.4.2.1.17. **JMF Adjustments.** If JMF adjustments are necessary to achieve the specified requirements, make the adjustment before beginning a new lot. The adjusted JMF must:

- be provided to the Engineer in writing before the start of a new lot;
- be numbered in sequence to the previous JMF;
- meet the mixture requirements in Table 4 and Table 5;
- meet the master gradation limits shown in Table 8; and
- be within the operational tolerances of JMF2 listed in Table 12.

- 4.4.2.1.18. **Requesting Referee Testing.** Use referee testing, if needed, in accordance with Section 344.4.9.1., “Referee Testing,” to resolve testing differences with the Engineer.

Table 12
Operational Tolerances

Description	Test Method	Allowable Difference Between Trial Batch and JMF1 Target	Allowable Difference from Current JMF Target	Allowable Difference between Contractor and Engineer ¹
Individual % retained for #8 sieve and larger	Tex-200-F or Tex-236-F	Must be Within Master Grading Limits in Table 8	±5.0 ^{2,3}	±5.0
Individual % retained for sieves smaller than #8 and larger than #200			±3.0 ^{2,3}	±3.0
% passing the #200 sieve			±2.0 ^{2,3}	±1.6
Asphalt binder content, %	Tex-236-F	±0.5	±0.3 ³	±0.3
Laboratory-molded density, %	Tex-207-F	±1.0	±1.0	±0.5
In-place air voids, %		N/A	N/A	±1.0
Laboratory-molded bulk specific gravity		N/A	N/A	±0.020
VMA, % min	Tex-204-F	Note ⁴	Note ⁴	N/A
Theoretical maximum specific (Rice) gravity	Tex-227-F	N/A	N/A	±0.020

1. Contractor may request referee testing only when values exceed these tolerances.
2. When within these tolerances, mixture production gradations may fall outside the master grading limits; however, the % passing the #200 will be considered out of tolerance when outside the master grading limits.
3. Only applies to mixture produced for Lot 1 and higher.
4. Test and verify that Table 8 requirements are met.

- 4.4.2.2. **Engineer’s Responsibilities.**

- 4.4.2.2.1. **Gyratory Compactor.** The Engineer will use a Department SGC, calibrated in accordance with Tex-241-F, to mold samples for laboratory mixture design verification. For molding trial batch and production specimens,

the Engineer will use the Contractor-provided SGC at the field laboratory or provide and use a Department SGC at an alternate location. The Engineer will make the Contractor-provided SGC in the Department field laboratory available to the Contractor for molding verification samples.

4.4.2.2.2. **Conditional Approval of JMF1 and Authorizing Trial Batch.** The Engineer will review and verify conformance of the following information within 2 working days of receipt:

- the Contractor's mix design report (JMF1);
- the Contractor-provided Hamburg Wheel test results;
- all required materials including aggregates, asphalt, additives, and recycled materials; and
- the mixture specifications.

The Engineer will grant the Contractor conditional approval of JMF1 if the information provided on the paper copy of JMF1 indicates that the Contractor's mixture design meets the specifications. When the Contractor does not provide Hamburg Wheel test results with laboratory mixture design, 10 working days are allowed for conditional approval of JMF1. The Engineer will base full approval of JMF1 on the test results on mixture from the trial batch.

Unless waived, the Engineer will determine the Micro-Deval abrasion loss in accordance with Section 344.2.1.1.2., "Micro-Deval Abrasion." If the Engineer's test results are pending after 2 working days, conditional approval of JMF1 will still be granted within 2 working days of receiving JMF1. When the Engineer's test results become available, they will be used for specification compliance.

After conditionally approving JMF1, including either Contractor- or Department-supplied Hamburg Wheel test results, the Contractor is authorized to produce a trial batch.

4.4.2.2.3. **Hamburg Wheel Testing of JMF1.** If the Contractor requests the option to have the Department perform the Hamburg Wheel test on the laboratory mixture, the Engineer will mold samples in accordance with Tex-242-F to verify compliance with the Hamburg Wheel test requirement in Table 11.

4.4.2.2.4. **Ignition Oven Correction Factors.** The Engineer will use the split samples provided by the Contractor to determine the aggregate and asphalt correction factors for the ignition oven used for QA testing during production in accordance with Tex-236-F.

4.4.2.2.5. **Testing the Trial Batch.** Within 1 full working day, the Engineer will sample and test the trial batch to ensure that the mixture meets the requirements in Table 12. If the Contractor requests the option to have the Department perform the Hamburg Wheel test on the trial batch mixture, the Engineer will mold samples in accordance with Tex-242-F to verify compliance with the Hamburg Wheel test requirement in Table 11.

The Engineer will have the option to perform the following tests on the trial batch:

- Tex-226-F, to verify that the indirect tensile strength meets the requirement shown in Table 10; and
- Tex-530-C, to retain and use for comparison purposes during production.

4.4.2.2.6. **Full Approval of JMF1.** The Engineer will grant full approval of JMF1 and authorize the Contractor to proceed with developing JMF2 if the Engineer's results for the trial batch meet the requirements in Table 12. The Engineer will notify the Contractor that an additional trial batch is required if the trial batch does not meet these requirements.

4.4.2.2.7. **Approval of JMF2.** The Engineer will approve JMF2 within one working day if the mixture meets the requirements in Table 5 and the gradation meets the master grading limits shown in Table 8. The asphalt binder content established for JMF2 is not required to be within any tolerance of the optimum asphalt binder content established for JMF1; however, mixture produced using JMF2 must meet the VMA requirements shown in Table 8. If the optimum asphalt binder content for JMF2 is more than 0.5% lower than the optimum asphalt binder content for JMF1, the Engineer may perform or require the Contractor to perform Tex-226-F on Lot 1 production to confirm the indirect tensile strength does not exceed 200 psi.

- 4.4.2.2.8. **Approval of Lot 1 Production.** The Engineer will authorize the Contractor to proceed with Lot 1 production (using JMF2) as soon as a passing result is achieved from the Department's or a Department-approved laboratory's Hamburg Wheel test on the trial batch. The Contractor may proceed at its own risk with Lot 1 production without the results from the Hamburg Wheel test on the trial batch.
- If the Department's or Department-approved laboratory's sample from the trial batch fails the Hamburg Wheel test, the Engineer will suspend production until further Hamburg Wheel tests meet the specified values. The Engineer may require up to the entire subplot of any mixture failing the Hamburg Wheel test be removed and replaced at the Contractor's expense.
- 4.4.2.2.9. **Approval of JMF3 and Subsequent JMF Changes.** JMF3 and subsequent JMF changes are approved if they meet the mixture requirements shown in Table 4, Table 5, and the master grading limits shown in Table 8, and are within the operational tolerances of JMF2 shown in Table 12.
- 4.5. **Production Operations.** Perform a new trial batch when the plant or plant location is changed. Take corrective action and receive approval to proceed after any production suspension for noncompliance to the specification. Submit a new mix design and perform a new trial batch when the asphalt binder content of:
- any RAP stockpile used in the mix is more than 0.5% higher than the value shown on the mixture design report; or
 - RAS stockpile used in the mix is more than 2.0% higher than the value shown on the mixture design report.
- 4.5.1. **Storage and Heating of Materials.** Do not heat the asphalt binder above the temperatures specified in Item 300, "Asphalts, Oils, and Emulsions," or outside the manufacturer's recommended values. Provide the Engineer with daily records of asphalt binder and hot-mix asphalt discharge temperatures (in legible and discernible increments) in accordance with Item 320, "Equipment for Asphalt Concrete Pavement," unless otherwise directed. Do not store mixture for a period long enough to affect the quality of the mixture, nor in any case longer than 12 hr. unless otherwise approved.
- 4.5.2. **Mixing and Discharge of Materials.** Notify the Engineer of the target discharge temperature and produce the mixture within 25°F of the target. Monitor the temperature of the material in the truck before shipping to ensure that it does not exceed 350°F (or 275°F for WMA) and is not lower than 215°F. The Department will not pay for or allow placement of any mixture produced above 350°F.
- Produce WMA within the target discharge temperature range of 215°F and 275°F when WMA is required. Take corrective action any time the discharge temperature of the WMA exceeds the target discharge range. The Engineer may suspend production operations if the Contractor's corrective action is not successful at controlling the production temperature within the target discharge range. Note that when WMA is produced, it may be necessary to adjust burners to ensure complete combustion such that no burner fuel residue remains in the mixture.
- Control the mixing time and temperature so that substantially all moisture is removed from the mixture before discharging from the plant. Determine the moisture content, if requested, by oven-drying in accordance with Tex-212-F, Part II, and verify that the mixture contains no more than 0.2% of moisture by weight. Obtain the sample immediately after discharging the mixture into the truck, and perform the test promptly.
- 4.6. **Hauling Operations.** Clean all truck beds before use to ensure that mixture is not contaminated. Use a release agent shown on the Department's MPL to coat the inside bed of the truck when necessary.
- Use equipment for hauling as defined in Section 344.4.7.3.3., "Hauling Equipment." Use other hauling equipment only when allowed.
- 4.7. **Placement Operations.** Collect haul tickets from each load of mixture delivered to the project and provide the Department's copy to the Engineer approximately every hour or as directed. Use a hand-held thermal camera or infrared thermometer, when a thermal imaging system is not used, to measure and record the internal temperature of the mixture as discharged from the truck or Material Transfer Device (MTD) before or

as the mix enters the paver and an approximate station number or GPS coordinates on each ticket. Calculate the daily yield and cumulative yield for the specified lift and provide to the Engineer at the end of paving operations for each day unless otherwise directed. The Engineer may suspend production if the Contractor fails to produce and provide haul tickets and yield calculations by the end of paving operations for each day.

Prepare the surface by removing raised pavement markers and objectionable material such as moisture, dirt, sand, leaves, and other loose impediments from the surface before placing mixture. Remove vegetation from pavement edges. Place the mixture to meet the typical section requirements and produce a smooth, finished surface with a uniform appearance and texture. Offset longitudinal joints of successive courses of hot-mix by at least 6 in. Place mixture so that longitudinal joints on the surface course coincide with lane lines, or as directed. Ensure that all finished surfaces will drain properly. Place the mixture at the rate or thickness shown on the plans. The Engineer will use the guidelines in Table 13 to determine the compacted lift thickness of each layer when multiple lifts are required. The thickness determined is based on the rate of 110 lb./sq. yd. for each inch of pavement unless otherwise shown on the plans.

Table 13
Compacted Lift Thickness and Required Core Height

Mixture Type	Compacted Lift Thickness Guidelines		Minimum Untrimmed Core Height (in.) Eligible for Testing
	Minimum (in.)	Maximum (in.)	
SP-A	3.00	5.0	2.50
SP-B	2.25	4.0	2.00
SP-C	1.50	3.0	1.25
SP-D	1.25	2.0	1.25

4.7.1. Weather Conditions.

4.7.1.1. **When Using a Thermal Imaging System.** The Contractor may pave any time the roadway is dry and the roadway surface temperature is at least 32°F; however, the Engineer may restrict the Contractor from paving surface mixtures if the ambient temperature is likely to drop below 32°F within 12 hr. of paving. Provide output data from the thermal imaging system to demonstrate to the Engineer that no recurring severe thermal segregation exists in accordance with Section 344.4.7.3.1.2., "Thermal Imaging System."

4.7.1.2. **When Not Using a Thermal Imaging System.** Place mixture when the roadway surface temperature is at or above the temperatures listed in Table 14 unless otherwise approved or as shown on the plans. Measure the roadway surface temperature with a hand-held thermal camera or infrared thermometer. The Engineer may allow mixture placement to begin before the roadway surface reaches the required temperature if conditions are such that the roadway surface will reach the required temperature within 2 hr. of beginning placement operations. Place mixtures only when weather conditions and moisture conditions of the roadway surface are suitable as determined by the Engineer. The Engineer may restrict the Contractor from paving if the ambient temperature is likely to drop below 32°F within 12 hr. of paving.

Table 14
Minimum Pavement Surface Temperatures

Originally Specified High Temperature Binder Grade	Minimum Pavement Surface Temperatures (°F)	
	Subsurface Layers or Night Paving Operations	Surface Layers Placed in Daylight Operations
PG 64 or lower	45	50
PG 70	55 ¹	60 ¹
PG 76 or higher	60 ¹	60 ¹

- Contractors may pave at temperatures 10°F lower than these values when utilizing a paving process including WMA or equipment that eliminates thermal segregation. In such cases, use a hand-held thermal camera operated in accordance with Tex-244-F to demonstrate to the satisfaction of the Engineer that the uncompacted mat has no more than 10°F of thermal segregation.

4.7.2. **Tack Coat.** Clean the surface before placing the tack coat. The Engineer will set the rate between 0.04 and 0.10 gal. of residual asphalt per square yard of surface area. Apply a uniform tack coat at the specified rate unless otherwise directed. Apply the tack coat in a uniform manner to avoid streaks and other irregular patterns. Apply a thin, uniform tack coat to all contact surfaces of curbs, structures, and all joints. Allow adequate time for emulsion to break completely before placing any material. Prevent splattering of tack coat

when placed adjacent to curb, gutter, and structures. Roll the tack coat with a pneumatic-tire roller to remove streaks and other irregular patterns when directed.

4.7.3. **Lay-Down Operations.**

4.7.3.1. **Thermal Profile.** Use a hand-held thermal camera or a thermal imaging system to obtain a continuous thermal profile in accordance with Tex-244-F. Thermal profiles are not applicable in areas described in Section 344.4.9.3.1.4., "Miscellaneous Areas."

4.7.3.1.1. **Thermal Segregation.**

4.7.3.1.1.1. **Moderate.** Any areas that have a temperature differential greater than 25°F, but not exceeding 50°F, are deemed as having moderate thermal segregation.

4.7.3.1.1.2. **Severe.** Any areas that have a temperature differential greater than 50°F are deemed as having severe thermal segregation.

4.7.3.1.2. **Thermal Imaging System.** Review the output results when a thermal imaging system is used, and provide the automated report described in Tex-244-F to the Engineer daily unless otherwise directed. Modify the paving process as necessary to eliminate any recurring (moderate or severe) thermal segregation identified by the thermal imaging system. The Engineer may suspend paving operations if the Contractor cannot successfully modify the paving process to eliminate recurring severe thermal segregation. Density profiles are not required and not applicable when using a thermal imaging system. Provide the Engineer with electronic copies of all daily data files that can be used with the thermal imaging system software to generate temperature profile plots upon completion of the project or as requested by the Engineer.

4.7.3.1.3. **Thermal Camera.** Take immediate corrective action to eliminate recurring moderate thermal segregation when a hand-held thermal camera is used. Evaluate areas with moderate thermal segregation by performing density profiles in accordance with Section 344.4.9.3.3.2., "Segregation (Density Profile)." Provide the Engineer with the thermal profile of every subplot within one working day of the completion of each lot. Report the results of each thermal profile in accordance with Section 344.4.2., "Reporting and Responsibilities." The Engineer will use a hand-held thermal camera to obtain a thermal profile at least once per project. No production or placement payment adjustments greater than 1.000 will be paid for any subplot that contains severe thermal segregation. Suspend operations and take immediate corrective action to eliminate severe thermal segregation unless otherwise directed. Resume operations when the Engineer determines that subsequent production will meet the requirements of this Section. Evaluate areas with severe thermal segregation by performing density profiles in accordance with Section 344.4.9.3.3.2., "Segregation (Density Profile)." Remove and replace the material in any areas that have both severe thermal segregation and a failing result for Segregation (Density Profile) unless otherwise directed. The subplot in question may receive a production and placement payment adjustment greater than 1.000, if applicable, when the defective material is successfully removed and replaced.

4.7.3.2. **Windrow Operations.** Operate windrow pickup equipment so that when hot-mix is placed in windrows, substantially all the mixture deposited on the roadbed is picked up and loaded into the paver.

4.7.3.3. **Hauling Equipment.** Use belly dumps, live bottom, or end dump trucks to haul and transfer mixture; however, with exception of paving miscellaneous areas, end dump trucks are only allowed when used in conjunction with an MTD with remixing capability or when a thermal imaging system is used unless otherwise allowed.

4.7.3.4. **Screed Heaters.** Turn off screed heaters to prevent overheating of the mat if the paver stops for more than 5 min. The Engineer may evaluate the suspect area in accordance with Section 344.4.9.3.3.4., "Recovered Asphalt Dynamic Shear Rheometer (DSR)," if the screed heater remains on for more than 5 min. while the paver is stopped.

4.8. **Compaction.** Compact the pavement uniformly to contain between 3.7% and 7.5% in-place air voids. Take immediate corrective action to bring the operation within 3.7% and 7.5% when the in-place air voids exceed

the range of these tolerances. The Engineer will allow paving to resume when the proposed corrective action is likely to yield between 3.7% and 7.5% in-place air voids.

Obtain cores in areas placed under Exempt Production, as directed, at locations determined by the Engineer. The Engineer may test these cores and suspend operations or require removal and replacement if the in-place air voids are less than 2.7% or more than 9.0%. Areas defined in Section 344.4.9.3.1.4., "Miscellaneous Areas," are not subject to in-place air void determination.

Furnish the type, size, and number of rollers required for compaction as approved. Use a pneumatic-tire roller to seal the surface unless excessive pickup of fines occurs. Use additional rollers as required to remove any roller marks. Use only water or an approved release agent on rollers, tamps, and other compaction equipment unless otherwise directed.

Use the control strip method shown in Tex-207-F, Part IV, on the first day of production to establish the rolling pattern that will produce the desired in-place air voids unless otherwise directed.

Use tamps to thoroughly compact the edges of the pavement along curbs, headers, and similar structures and in locations that will not allow thorough compaction with rollers. The Engineer may require rolling with a trench roller on widened areas, in trenches, and in other limited areas.

Complete all compaction operations before the pavement temperature drops below 160°F unless otherwise allowed. The Engineer may allow compaction with a light finish roller operated in static mode for pavement temperatures below 160°F.

Allow the compacted pavement to cool to 160°F or lower before opening to traffic unless otherwise directed. Sprinkle the finished mat with water or limewater, when directed, to expedite opening the roadway to traffic.

- 4.9. **Acceptance Plan.** Payment adjustments for the material will be in accordance with Article 344.6., "Payment."

Sample and test the hot-mix on a lot and subplot basis. Suspend production until test results or other information indicates to the satisfaction of the Engineer that the next material produced or placed will result in pay factors of at least 1.000 if the production pay factor given in Section 344.6.1., "Production Payment Adjustment Factors," for 2 consecutive lots or the placement pay factor given in Section 344.6.2., "Placement Payment Adjustment Factors," for 2 consecutive lots is below 1.000.

- 4.9.1. **Referee Testing.** The Construction Division is the referee laboratory. The Contractor may request referee testing if a "remove and replace" condition is determined based on the Engineer's test results, or if the differences between Contractor and Engineer test results exceed the maximum allowable difference shown in Table 12 and the differences cannot be resolved. The Contractor may also request referee testing if the Engineer's test results require suspension of production and the Contractor's test results are within specification limits. Make the request within 5 working days after receiving test results and cores from the Engineer. Referee tests will be performed only on the subplot in question and only for the particular tests in question. Allow 10 working days from the time the referee laboratory receives the samples for test results to be reported. The Department may require the Contractor to reimburse the Department for referee tests if more than 3 referee tests per project are required and the Engineer's test results are closer to the referee test results than the Contractor's test results.

The Construction Division will determine the laboratory-molded density based on the molded specific gravity and the maximum theoretical specific gravity of the referee sample. The in-place air voids will be determined based on the bulk specific gravity of the cores, as determined by the referee laboratory and the Engineer's average maximum theoretical specific gravity for the lot. With the exception of "remove and replace" conditions, referee test results are final and will establish payment adjustment factors for the subplot in question. The Contractor may decline referee testing and accept the Engineer's test results when the placement payment adjustment factor for any subplot results in a "remove and replace" condition. Placement sublots subject to be removed and replaced will be further evaluated in accordance with Section 344.6.2.2., "Placement Sublots Subject to Removal and Replacement."

4.9.2. **Production Acceptance.**

- 4.9.2.1. **Production Lot.** A production lot consists of 4 equal sublots. The default quantity for Lot 1 is 1,000 tons; however, when requested by the Contractor, the Engineer may increase the quantity for Lot 1 to no more than 4,000 tons. The Engineer will select subsequent lot sizes based on the anticipated daily production such that approximately 3 to 4 sublots are produced each day. The lot size will be between 1,000 tons and 4,000 tons. The Engineer may change the lot size before the Contractor begins any lot.

If the optimum asphalt binder content for JMF2 is more than 0.5% lower than the optimum asphalt binder content for JMF1, the Engineer may perform or require the Contractor to perform Tex-226-F on Lot 1 to confirm the indirect tensile strength does not exceed 200 psi. Take corrective action to bring the mixture within specification compliance if the indirect tensile strength exceeds 200 psi unless otherwise directed.

- 4.9.2.1.1. **Incomplete Production Lots.** If a lot is begun but cannot be completed, such as on the last day of production or in other circumstances deemed appropriate, the Engineer may close the lot. Adjust the payment for the incomplete lot in accordance with Section 344.6.1., "Production Payment Adjustment Factors." Close all lots within 5 working days unless otherwise allowed.

4.9.2.2. **Production Sampling.**

- 4.9.2.2.1. **Mixture Sampling.** Obtain hot-mix samples from trucks at the plant in accordance with Tex-222-F. The sampler will split each sample into 3 equal portions in accordance with Tex-200-F and label these portions as "Contractor," "Engineer," and "Referee." The Engineer will perform or witness the sample splitting and take immediate possession of the samples labeled "Engineer" and "Referee." The Engineer will maintain the custody of the samples labeled "Engineer" and "Referee" until the Department's testing is completed.

- 4.9.2.2.1.1. **Random Sample.** At the beginning of the project, the Engineer will select random numbers for all production sublots. Determine sample locations in accordance with Tex-225-F. Take one sample for each subplot at the randomly selected location. The Engineer will perform or witness the sampling of production sublots.

- 4.9.2.2.1.2. **Blind Sample.** For one subplot per lot, the Engineer will obtain and test a "blind" sample instead of the random sample collected by the Contractor. Test either the "blind" or the random sample; however, referee testing (if applicable) will be based on a comparison of results from the "blind" sample. The location of the Engineer's "blind" sample will not be disclosed to the Contractor. The Engineer's "blind" sample may be randomly selected in accordance with Tex-225-F for any subplot or selected at the discretion of the Engineer. The Engineer will use the Contractor's split sample for sublots not sampled by the Engineer.

- 4.9.2.2.2. **Informational Cantabro and Overlay Testing.** Select one random subplot from Lot 2 or higher for Cantabro and Overlay testing during the first week of production. Obtain and provide the Engineer with approximately 90 lb. (40 kg) of mixture in sealed containers, boxes, or bags labeled with Control Section Job (CSJ), mixture type, lot, and subplot number. The Engineer will ship the mixture to the Construction Division for Cantabro and Overlay testing. Results from these tests will not be used for specification compliance.

- 4.9.2.2.3. **Asphalt Binder Sampling.** Obtain a 1-qt. sample of the asphalt binder for each lot of mixture produced. Obtain the sample at approximately the same time the mixture random sample is obtained. Sample from a port located immediately upstream from the mixing drum or pug mill in accordance with Tex-500-C, Part II. Label the can with the corresponding lot and subplot numbers and deliver the sample to the Engineer. The Engineer may also obtain independent samples. If obtaining an independent asphalt binder sample, the Engineer will split a sample of the asphalt binder with the Contractor. The Engineer will test at least one asphalt binder sample per project to verify compliance with Item 300, "Asphalts, Oils, and Emulsions."

- 4.9.2.3. **Production Testing.** The Contractor and Engineer must perform production tests in accordance with Table 15. The Contractor has the option to verify the Engineer's test results on split samples provided by the Engineer. Determine compliance with operational tolerances listed in Table 12 for all sublots.

Take immediate corrective action if the Engineer's laboratory-molded density on any subplot is less than 95.0% or greater than 97.0% to bring the mixture within these tolerances. The Engineer may suspend

operations if the Contractor's corrective actions do not produce acceptable results. The Engineer will allow production to resume when the proposed corrective action is likely to yield acceptable results.

The Engineer may allow alternate methods for determining the asphalt binder content and aggregate gradation if the aggregate mineralogy is such that Tex-236-F does not yield reliable results. Provide evidence that results from Tex-236-F are not reliable before requesting permission to use an alternate method unless otherwise directed. Use the applicable test procedure as directed if an alternate test method is allowed.

Table 15
Production and Placement Testing Frequency

Description	Test Method	Minimum Contractor Testing Frequency	Minimum Engineer Testing Frequency
Individual % retained for #8 sieve and larger	Tex-200-F or Tex-236-F	1 per subplot	1 per 12 sublots ¹
Individual % retained for sieves smaller than #8 and larger than #200			
% passing the #200 sieve			
Laboratory-molded density	Tex-207-F	N/A	1 per subplot ¹
Laboratory-molded bulk specific gravity			
In-place air voids			
VMA	Tex-204-F		
Segregation (density profile) ²	Tex-207-F, Part V	1 per subplot	1 per project
Longitudinal joint density	Tex-207-F, Part VII		
Moisture content	Tex-212-F, Part II	When directed	
Theoretical maximum specific (Rice) gravity	Tex-227-F	N/A	1 per subplot ¹
Asphalt binder content	Tex-236-F	1 per subplot	1 per lot ¹
Hamburg Wheel test	Tex-242-F	N/A	1 per project
Recycled Asphalt Shingles (RAS) ³	Tex-217-F, Part III	N/A	
Thermal profile ²	Tex-244-F	1 per subplot	
Asphalt binder sampling and testing	Tex-500-C	1 per lot (sample only)	
Tack coat sampling and testing	Tex-500-C, Part III	N/A	
Boil test ⁴	Tex-530-C	1 per lot	
Cantabro loss ⁵	Tex-245-F	1 per project	
Overlay test ⁵	Tex-248-F	(sample only)	

1. For production defined in Section 344.4.9.4., "Exempt Production," the Engineer will test one per day if 100 tons or more are produced. For Exempt Production, no testing is required when less than 100 tons are produced.
2. Not required when a thermal imaging system is used.
3. Testing performed by the Construction Division or designated laboratory.
4. The Engineer may reduce or waive the sampling and testing requirements based on a satisfactory test history.
5. Testing performed by the Construction Division and for informational purposes only.

4.9.2.4. **Operational Tolerances.** Control the production process within the operational tolerances listed in Table 12. When production is suspended, the Engineer will allow production to resume when test results or other information indicates the next mixture produced will be within the operational tolerances.

4.9.2.4.1. **Gradation.** Suspend operation and take corrective action if any aggregate is retained on the maximum sieve size shown in Table 8. A subplot is defined as out of tolerance if either the Engineer's or the Contractor's test results are out of operational tolerance. Suspend production when test results for gradation exceed the operational tolerances for 3 consecutive sublots on the same sieve or 4 consecutive sublots on any sieve unless otherwise directed. The consecutive sublots may be from more than one lot.

4.9.2.4.2. **Asphalt Binder Content.** A subplot is defined as out of operational tolerance if either the Engineer's or the Contractor's test results exceed the values listed in Table 12. No production or placement payment adjustments greater than 1.000 will be paid for any subplot that is out of operational tolerance for asphalt binder content. Suspend production and shipment of the mixture if the Engineer's or the Contractor's asphalt binder content deviates from the current JMF by more than 0.5% for any subplot.

- 4.9.2.4.3. **Voids in Mineral Aggregates (VMA).** The Engineer will determine the VMA for every subplot. For sublots when the Engineer does not determine asphalt binder content, the Engineer will use the asphalt binder content results from QC testing performed by the Contractor to determine VMA.
- Take immediate corrective action if the VMA value for any subplot is less than the minimum VMA requirement for production listed in Table 8. Suspend production and shipment of the mixture if the Engineer's VMA results on 2 consecutive sublots are below the minimum VMA requirement for production listed in Table 8. No production or placement payment adjustments greater than 1.000 will be paid for any subplot that does not meet the minimum VMA requirement for production listed in Table 8 based on the Engineer's VMA determination.
- Suspend production and shipment of the mixture if the Engineer's VMA result is more than 0.5% below the minimum VMA requirement for production listed in Table 8. In addition to suspending production, the Engineer may require removal and replacement or may allow the subplot to be left in place without payment.
- 4.9.2.4.4. **Hamburg Wheel Test.** The Engineer may perform a Hamburg Wheel test at any time during production, including when the boil test indicates a change in quality from the materials submitted for JMF1. In addition to testing production samples, the Engineer may obtain cores and perform Hamburg Wheel tests on any areas of the roadway where rutting is observed. Suspend production until further Hamburg Wheel tests meet the specified values when the production or core samples fail the Hamburg Wheel test criteria in Table 11. Core samples, if taken, will be obtained from the center of the finished mat or other areas excluding the vehicle wheel paths. The Engineer may require up to the entire subplot of any mixture failing the Hamburg Wheel test to be removed and replaced at the Contractor's expense.
- If the Department's or Department approved laboratory's Hamburg Wheel test results in a "remove and replace" condition, the Contractor may request that the Department confirm the results by re-testing the failing material. The Construction Division will perform the Hamburg Wheel tests and determine the final disposition of the material in question based on the Department's test results.
- 4.9.2.5. **Individual Loads of Hot-Mix.** The Engineer can reject individual truckloads of hot-mix. When a load of hot-mix is rejected for reasons other than temperature, contamination, or excessive uncoated particles, the Contractor may request that the rejected load be tested. Make this request within 4 hr. of rejection. The Engineer will sample and test the mixture. If test results are within the operational tolerances shown in Table 12, payment will be made for the load. If test results are not within operational tolerances, no payment will be made for the load.
- 4.9.3. **Placement Acceptance.**
- 4.9.3.1. **Placement Lot.** A placement lot consists of 4 placement sublots. A placement subplot consists of the area placed during a production subplot.
- 4.9.3.1.1. **Lot 1 Placement.** Placement payment adjustments greater than 1.000 for Lot 1 will be in accordance with Section 344.6.2., "Placement Payment Adjustment Factors;" however, no placement adjustment less than 1.000 will be assessed for any subplot placed in Lot 1 when the in-place air voids are greater than or equal to 2.7% and less than or equal to 9.0%. Remove and replace any subplot with in-place air voids less than 2.7% or greater than 9.0%.
- 4.9.3.1.2. **Incomplete Placement Lots.** An incomplete placement lot consists of the area placed as described in Section 344.4.9.2.1.1., "Incomplete Production Lot," excluding areas defined in Section 344.4.9.3.1.4., "Miscellaneous Areas." Placement sampling is required if the random sample plan for production resulted in a sample being obtained from an incomplete production subplot.
- 4.9.3.1.3. **Shoulders, Ramps, Etc.** Shoulders, ramps, intersections, acceleration lanes, deceleration lanes, and turn lanes are subject to in-place air void determination and payment adjustments unless designated on the plans as not eligible for in-place air void determination. Intersections may be considered miscellaneous areas when determined by the Engineer.

4.9.3.1.4. **Miscellaneous Areas.** Miscellaneous areas include areas that typically involve significant handwork or discontinuous paving operations, such as temporary detours, driveways, mailbox turnouts, crossovers, gores, spot level-up areas, and other similar areas. Temporary detours are subject to in-place air void determination when shown on the plans. Miscellaneous areas also include level-ups and thin overlays when the layer thickness specified on the plans is less than the minimum untrimmed core height eligible for testing shown in Table 13. The specified layer thickness is based on the rate of 110 lb./sq. yd. for each inch of pavement unless another rate is shown on the plans. When "level up" is listed as part of the item bid description code, a payment adjustment factor of 1.000 will be assigned for all placement sublots as described in Article 344.6, "Payment." Miscellaneous areas are not eligible for random placement sampling locations. Compact miscellaneous areas in accordance with Section 344.4.8., "Compaction." Miscellaneous areas are not subject to in-place air void determination, thermal profiles testing, segregation (density profiles), or longitudinal joint density evaluations.

4.9.3.2. **Placement Sampling.** The Engineer will select random numbers for all placement sublots at the beginning of the project. The Engineer will provide the Contractor with the placement random numbers immediately after the subplot is completed. Mark the roadway location at the completion of each subplot and record the station number. Determine one random sample location for each placement subplot in accordance with Tex-225-F. Adjust the random sample location by no more than necessary to achieve a 2-ft. clearance if the location is within 2 ft. of a joint or pavement edge.

Shoulders, ramps, intersections, acceleration lanes, deceleration lanes, and turn lanes are always eligible for selection as a random sample location; however, if a random sample location falls on one of these areas and the area is designated on the plans as not subject to in-place air void determination, cores will not be taken for the subplot and a 1.000 pay factor will be assigned to that subplot.

Provide the equipment and means to obtain and trim roadway cores on-site. On-site is defined as in close proximity to where the cores are taken. Obtain the cores within one working day of the time the placement subplot is completed unless otherwise approved. Obtain two 6-in. diameter cores side-by-side from within 1 ft. of the random location provided for the placement subplot. For SP-C and SP-D mixtures, 4-in. diameter cores are allowed. Mark the cores for identification, measure and record the untrimmed core height, and provide the information to the Engineer. The Engineer will witness the coring operation and measurement of the core thickness. Visually inspect each core and verify that the current paving layer is bonded to the underlying layer. Take corrective action if an adequate bond does not exist between the current and underlying layer to ensure that an adequate bond will be achieved during subsequent placement operations.

Trim the cores immediately after obtaining the cores from the roadway in accordance with Tex-207-F if the core heights meet the minimum untrimmed value listed in Table 13. Trim the cores on-site in the presence of the Engineer. Use a permanent marker or paint pen to record the lot and subplot numbers on each core as well as the designation as Core A or B. The Engineer may require additional information to be marked on the core and may choose to sign or initial the core. The Engineer will take custody of the cores immediately after they are trimmed and will retain custody of the cores until the Department's testing is completed. Before turning the trimmed cores over to the Engineer, the Contractor may wrap the trimmed cores or secure them in a manner that will reduce the risk of possible damage occurring during transport by the Engineer. After testing, the Engineer will return the cores to the Contractor.

The Engineer may have the cores transported back to the Department's laboratory at the HMA plant via the Contractor's haul truck or other designated vehicle. In such cases where the cores will be out of the Engineer's possession during transport, the Engineer will use Department-provided security bags and the Roadway Core Custody protocol located at <http://www.txdot.gov/business/specifications.htm> to provide a secure means and process that protects the integrity of the cores during transport.

Decide whether to include the pair of cores in the air void determination for that subplot if the core height before trimming is less than the minimum untrimmed value shown in Table 13.

Trim the cores as described above before delivering to the Engineer if electing to have the cores included in the air void determination. Deliver untrimmed cores to the Engineer and inform the Engineer of the decision to not have the cores included in air void determination if electing to not have the cores included in air void

determination. The placement pay factor for the subplot will be 1.000 if cores will not be included in air void determination.

Instead of the Contractor trimming the cores on-site immediately after coring, the Engineer and the Contractor may mutually agree to have the trimming operations performed at an alternate location such as a field laboratory or other similar location. In such cases, the Engineer will take possession of the cores immediately after they are obtained from the roadway and will retain custody of the cores until testing is completed. Either the Department or Contractor representative may perform trimming of the cores. The Engineer will witness all trimming operations in cases where the Contractor representative performs the trimming operation.

Dry the core holes and tack the sides and bottom immediately after obtaining the cores. Fill the hole with the same type of mixture and properly compact the mixture. Repair core holes with other methods when approved.

4.9.3.3. **Placement Testing.** Perform placement tests in accordance with Table 15. After the Engineer returns the cores, the Contractor may test the cores to verify the Engineer's test results for in-place air voids. The allowable differences between the Contractor's and Engineer's test results are listed in Table 12.

4.9.3.3.1. **In-Place Air Voids.** The Engineer will measure in-place air voids in accordance with Tex-207-F and Tex-227-F. Before drying to a constant weight, cores may be pre-dried using a Corelok or similar vacuum device to remove excess moisture. The Engineer will average the values obtained for all sublots in the production lot to determine the theoretical maximum specific gravity. The Engineer will use the average air void content for in-place air voids.

The Engineer will use the vacuum method to seal the core if required by Tex-207-F. The Engineer will use the test results from the unsealed core to determine the placement payment adjustment factor if the sealed core yields a higher specific gravity than the unsealed core. After determining the in-place air void content, the Engineer will return the cores and provide test results to the Contractor.

4.9.3.3.2. **Segregation (Density Profile).** Test for segregation using density profiles in accordance with Tex-207-F, Part V. Density profiles are not required and are not applicable when using a thermal imaging system. Density profiles are not applicable in areas described in Section 344.4.9.3.1.4., "Miscellaneous Areas."

Perform a density profile every time the paver stops for more than 60 sec. on areas that are identified by either the Contractor or the Engineer as having thermal segregation, and on any visibly segregated areas unless otherwise approved. Perform a minimum of one profile per subplot if the paver does not stop for more than 60 sec. and there are no visibly segregated areas or areas that are identified as having thermal segregation.

Provide the Engineer with the density profile of every subplot in the lot within one working day of the completion of each lot. Report the results of each density profile in accordance with Section 344.4.2., "Reporting and Responsibilities."

The density profile is considered failing if it exceeds the tolerances in Table 16. No production or placement payment adjustments greater than 1.000 will be paid for any subplot that contains a failing density profile. When a hand-held thermal camera is used instead of a thermal imaging system, the Engineer will measure the density profile at least once per project. The Engineer's density profile results will be used when available. The Engineer may require the Contractor to remove and replace the area in question if the area fails the density profile and has surface irregularities as defined in Section 344.4.9.3.3.5., "Irregularities." The subplot in question may receive a production and placement payment adjustment greater than 1.000, if applicable, when the defective material is successfully removed and replaced.

Investigate density profile failures and take corrective actions during production and placement to eliminate the segregation. Suspend production if 2 consecutive density profiles fail unless otherwise approved. Resume production after the Engineer approves changes to production or placement methods.

Table 16
Segregation (Density Profile) Acceptance Criteria

Mixture Type	Maximum Allowable Density Range (Highest to Lowest)	Maximum Allowable Density Range (Average to Lowest)
SP-A & SP-B	8.0 pcf	5.0 pcf
SP-C & SP-D	6.0 pcf	3.0 pcf

4.9.3.3.3. **Longitudinal Joint Density.**

4.9.3.3.3.1. **Informational Tests.** Perform joint density evaluations while establishing the rolling pattern and verify that the joint density is no more than 3.0 pcf below the density taken at or near the center of the mat. Adjust the rolling pattern, if needed, to achieve the desired joint density. Perform additional joint density evaluations at least once per subplot unless otherwise directed.

4.9.3.3.3.2. **Record Tests.** Perform a joint density evaluation for each subplot at each pavement edge that is or will become a longitudinal joint. Joint density evaluations are not applicable in areas described in Section 344.4.9.3.1.4., "Miscellaneous Areas." Determine the joint density in accordance with Tex-207-F, Part VII. Record the joint density information and submit results on Department forms to the Engineer. The evaluation is considered failing if the joint density is more than 3.0 pcf below the density taken at the core random sample location and the correlated joint density is less than 90.0%. The Engineer will make independent joint density verification at least once per project and may make independent joint density verifications at the random sample locations. The Engineer's joint density test results will be used when available.

Provide the Engineer with the joint density of every subplot in the lot within one working day of the completion of each lot. Report the results of each joint density in accordance with Section 344.4.2., "Reporting and Responsibilities."

Investigate joint density failures and take corrective actions during production and placement to improve the joint density. Suspend production if the evaluations on 2 consecutive sublots fail unless otherwise approved. Resume production after the Engineer approves changes to production or placement methods.

4.9.3.3.4. **Recovered Asphalt Dynamic Shear Rheometer (DSR).** The Engineer may take production samples or cores from suspect areas of the project to determine recovered asphalt properties. Asphalt binders with an aging ratio greater than 3.5 do not meet the requirements for recovered asphalt properties and may be deemed defective when tested and evaluated by the Construction Division. The aging ratio is the DSR value of the extracted binder divided by the DSR value of the original unaged binder. Obtain DSR values in accordance with AASHTO T 315 at the specified high temperature performance grade of the asphalt. The Engineer may require removal and replacement of the defective material at the Contractor's expense. The asphalt binder will be recovered for testing from production samples or cores in accordance with Tex-211-F.

4.9.3.3.5. **Irregularities.** Identify and correct irregularities including segregation, rutting, raveling, flushing, fat spots, mat slippage, irregular color, irregular texture, roller marks, tears, gouges, streaks, uncoated aggregate particles, or broken aggregate particles. The Engineer may also identify irregularities, and in such cases, the Engineer will promptly notify the Contractor. If the Engineer determines that the irregularity will adversely affect pavement performance, the Engineer may require the Contractor to remove and replace (at the Contractor's expense) areas of the pavement that contain irregularities and areas where the mixture does not bond to the existing pavement.

If irregularities are detected, the Engineer may require the Contractor to immediately suspend operations or may allow the Contractor to continue operations for no more than one day while the Contractor is taking appropriate corrective action.

4.9.4. **Exempt Production.** The Engineer may deem the mixture as exempt production for the following conditions:

- anticipated daily production is less than 1,000 tons;
- total production for the project is less than 5,000 tons;

- when mutually agreed between the Engineer and the Contractor; or
- when shown on the plans.

For exempt production, the Contractor is relieved of all production and placement QC/QA sampling and testing requirements, and the production and placement pay factors are 1.000. All other specification requirements apply, and the Engineer will perform acceptance tests for production and placement listed in Table 15 when 100 tons or more per day are produced.

For exempt production:

- produce, haul, place, and compact the mixture in compliance with the specification and as directed;
- control mixture production to yield a laboratory-molded density that is within $\pm 1.0\%$ of the target laboratory-molded density as tested by the Engineer;
- compact the mixture in accordance with Section 344.4.8., "Compaction"; and
- when a thermal imaging system is not used, the Engineer may perform segregation (density profiles) and thermal profiles in accordance with the specification.

- 4.9.5. **Ride Quality.** Measure ride quality in accordance with Item 585, "Ride Quality for Pavement Surfaces," unless otherwise shown on the plans.

5. MEASUREMENT

Hot mix will be measured by the ton of composite hot-mix, which includes asphalt, aggregate, and additives. Measure the weight on scales in accordance with Item 520, "Weighing and Measuring Equipment."

6. PAYMENT

The work performed and materials furnished in accordance with this Item and measured as provided under Article 344.5., "Measurement," will be paid for at the unit bid price for "Superpave Mixtures" of the mixture type, SAC, and binder specified. These prices are full compensation for surface preparation, materials including tack coat, placement, equipment, labor, tools, and incidentals.

Payment adjustments will be applied as determined in this Item; however, a payment adjustment factor of 1.000 will be assigned for all placement sublots for "level ups" only when "level up" is listed as part of the item bid description code. A payment adjustment factor of 1.000 will be assigned to all production and placement sublots when "exempt" is listed as part of the item bid description code.

Payment for each subplot, including applicable payment adjustments greater than 1.000, will only be paid for sublots when the Contractor supplies the Engineer with the required documentation for production and placement QC/QA, thermal profiles, segregation density profiles, and longitudinal joint densities in accordance with Section 344.4.2., "Reporting and Responsibilities." When a thermal imaging system is used, documentation is not required for thermal profiles or segregation density profiles on individual sublots; however, the thermal imaging system automated reports described in Tex-244-F are required.

Trial batches will not be paid for unless they are included in pavement work approved by the Department.

Payment adjustment for ride quality will be determined in accordance with Item 585, "Ride Quality for Pavement Surfaces."

- 6.1. **Production Payment Adjustment Factors.** The production payment adjustment factor is based on the laboratory-molded density using the Engineer's test results. A payment adjustment factor will be determined from Table 17 for each subplot using the deviation from the target laboratory-molded density defined in Table 10. The production payment adjustment factor for completed lots will be the average of the payment adjustment factors for the 4 sublots sampled within that lot.

Table 17
Production Payment Adjustment Factors for Laboratory-Molded Density¹

Absolute Deviation from Target Laboratory-Molded Density	Production Payment Adjustment Factor (Target Laboratory-Molded Density)
0.0	1.075
0.1	1.075
0.2	1.075
0.3	1.066
0.4	1.057
0.5	1.047
0.6	1.038
0.7	1.029
0.8	1.019
0.9	1.010
1.0	1.000
1.1	0.900
1.2	0.800
1.3	0.700
> 1.3	Remove and replace

1. If the Engineer's laboratory-molded density on any subplot is less than 95.0% or greater than 97.0%, take immediate corrective action to bring the mixture within these tolerances. The Engineer may suspend operations if the Contractor's corrective actions do not produce acceptable results. The Engineer will allow production to resume when the proposed corrective action is likely to yield acceptable results.

- 6.1.1. **Payment for Incomplete Production Lots.** Production payment adjustments for incomplete lots, described under Section 344.4.9.2.1.1., "Incomplete Production Lots," will be calculated using the average production pay factors from all sublots sampled. A production payment factor of 1.000 will be assigned to any lot when the random sampling plan did not result in collection of any samples.
- 6.1.2. **Production Sublots Subject to Removal and Replacement.** If after referee testing, the laboratory-molded density for any subplot results in a "remove and replace" condition as listed in Table 17, the Engineer may require removal and replacement or may allow the subplot to be left in place without payment. The Engineer may also accept the subplot in accordance with Section 5.3.1., "Acceptance of Defective or Unauthorized Work." Replacement material meeting the requirements of this Item will be paid for in accordance with this Section.
- 6.2. **Placement Payment Adjustment Factors.** The placement payment adjustment factor is based on in-place air voids using the Engineer's test results. A payment adjustment factor will be determined from Table 18 for each subplot that requires in-place air void measurement. A placement payment adjustment factor of 1.000 will be assigned to the entire subplot when the random sample location falls in an area designated on the plans as not subject to in-place air void determination. A placement payment adjustment factor of 1.000 will be assigned to quantities placed in areas described in Section 344.4.9.3.1.4., "Miscellaneous Areas." The placement payment adjustment factor for completed lots will be the average of the placement payment adjustment factors for up to 4 sublots within that lot.

Table 18
Placement Payment Adjustment Factors for In-Place Air Voids

In-Place Air Voids	Placement Payment Adjustment Factor	In-Place Air Voids	Placement Payment Adjustment Factor
< 2.7	Remove and Replace	5.9	1.048
2.7	0.710	6.0	1.045
2.8	0.740	6.1	1.042
2.9	0.770	6.2	1.039
3.0	0.800	6.3	1.036
3.1	0.830	6.4	1.033
3.2	0.860	6.5	1.030
3.3	0.890	6.6	1.027
3.4	0.920	6.7	1.024
3.5	0.950	6.8	1.021
3.6	0.980	6.9	1.018
3.7	1.000	7.0	1.015
3.8	1.015	7.1	1.012
3.9	1.030	7.2	1.009
4.0	1.045	7.3	1.006
4.1	1.060	7.4	1.003
4.2	1.075	7.5	1.000
4.3	1.075	7.6	0.980
4.4	1.075	7.7	0.960
4.5	1.075	7.8	0.940
4.6	1.075	7.9	0.920
4.7	1.075	8.0	0.900
4.8	1.075	8.1	0.880
4.9	1.075	8.2	0.860
5.0	1.075	8.3	0.840
5.1	1.072	8.4	0.820
5.2	1.069	8.5	0.800
5.3	1.066	8.6	0.780
5.4	1.063	8.7	0.760
5.5	1.060	8.8	0.740
5.6	1.057	8.9	0.720
5.7	1.054	9.0	0.700
5.8	1.051	> 9.0	Remove and Replace

6.2.1. **Payment for Incomplete Placement Lots.** Payment adjustments for incomplete placement lots described under Section 344.4.9.3.1.2., "Incomplete Placement Lots," will be calculated using the average of the placement pay factors from all sublots sampled and sublots where the random location falls in an area designated on the plans as not eligible for in-place air void determination. A placement payment adjustment factor of 1.000 will be assigned to any lot when the random sampling plan did not result in collection of any samples.

6.2.2. **Placement Sublots Subject to Removal and Replacement.** If after referee testing, the placement payment adjustment factor for any subplot results in a "remove and replace" condition as listed in Table 18, the Engineer will choose the location of 2 cores to be taken within 3 ft. of the original failing core location. The Contractor will obtain the cores in the presence of the Engineer. The Engineer will take immediate possession of the untrimmed cores and submit the untrimmed cores to the Construction Division, where they will be trimmed, if necessary, and tested for bulk specific gravity within 10 working days of receipt.

The average bulk specific gravity of the cores will be divided by the Engineer's average maximum theoretical specific gravity for that lot to determine the new payment adjustment factor of the subplot in question. If the new payment adjustment factor is 0.700 or greater, the new payment adjustment factor will apply to that subplot. If the new payment adjustment factor is less than 0.700, no payment will be made for the subplot. Remove and replace the failing subplot, or the Engineer may allow the subplot to be left in place without payment. The Engineer may also accept the subplot in accordance with Section 5.3.1., "Acceptance of Defective or Unauthorized Work." Replacement material meeting the requirements of this Item will be paid for in accordance with this Section.

- 6.3. **Total Adjusted Pay Calculation.** Total adjusted pay (TAP) will be based on the applicable payment adjustment factors for production and placement for each lot.

$$TAP = (A+B)/2$$

where:

A = Bid price × production lot quantity × average payment adjustment factor for the production lot

B = Bid price × placement lot quantity × average payment adjustment factor for the placement lot + (bid price × quantity placed in miscellaneous areas × 1.000)

Production lot quantity = Quantity actually placed - quantity left in place without payment

Placement lot quantity = Quantity actually placed - quantity left in place without payment - quantity placed in miscellaneous areas

Item 346

Stone-Matrix Asphalt



1. DESCRIPTION

Construct a hot-mix asphalt (HMA) pavement layer composed of compacted stone-matrix asphalt (SMA) or stone-matrix asphalt rubber (SMAR) mixture of aggregate, asphalt binder, and additives mixed hot in a mixing plant. Payment adjustments will apply to HMA placed under this specification unless the HMA is deemed exempt in accordance with Section 346.4.9.4., "Exempt Production."

2. MATERIALS

Furnish uncontaminated materials of uniform quality that meet the requirements of the plans and specifications.

Notify the Engineer of all material sources and before changing any material source or formulation. The Engineer will verify that the specification requirements are met when the Contractor makes a source or formulation change, and may require a new laboratory mixture design, trial batch, or both. The Engineer may sample and test project materials at any time during the project to verify specification compliance in accordance with Item 6, "Control of Materials."

- 2.1. **Aggregate.** Furnish aggregates from sources that conform to the requirements shown in Table 1 and as specified in this Section. Aggregate requirements in this Section, including those shown in Table 1, may be modified or eliminated when shown on the plans. Additional aggregate requirements may be specified when shown on the plans. Provide aggregate stockpiles that meet the definitions in this Section for coarse, intermediate, or fine aggregate. Aggregate from reclaimed asphalt pavement (RAP) is not required to meet Table 1 requirements unless otherwise shown on the plans. Supply aggregates that meet the definitions in Tex-100-E for crushed gravel or crushed stone. The Engineer will designate the plant or the quarry as the sampling location. Provide samples from materials produced for the project. The Engineer will establish the Surface Aggregate Classification (SAC) and perform Los Angeles abrasion, magnesium sulfate soundness, and Micro-Deval tests. Perform all other aggregate quality tests listed in Table 1. Document all test results on the mixture design report. The Engineer may perform tests on independent or split samples to verify Contractor test results. Stockpile aggregates for each source and type separately. Determine aggregate gradations for mixture design and production testing based on the washed sieve analysis given in Tex-200-F, Part II.

- 2.1.1. **Coarse Aggregate.** Coarse aggregate stockpiles must have no more than 20% material passing the No. 8 sieve. Aggregates from sources listed in the Department's *Bituminous Rated Source Quality Catalog* (BRSQC) are preapproved for use. Use only the rated values for hot-mix listed in the BRSQC. Rated values for surface treatment (ST) do not apply to coarse aggregate sources used in hot-mix asphalt.

For sources not listed on the Department's BRSQC:

- build an individual stockpile for each material;
- request the Department test the stockpile for specification compliance; and
- once approved, do not add material to the stockpile unless otherwise approved.

Provide aggregate from non-listed sources only when tested by the Engineer and approved before use. Allow 30 calendar days for the Engineer to sample, test, and report results for non-listed sources.

Provide coarse aggregate with at least the minimum SAC shown on the plans. SAC requirements only apply to aggregates used on the surface of travel lanes. SAC requirements apply to aggregates used on surfaces

other than travel lanes when shown on the plans. The SAC for sources on the Department's *Aggregate Quality Monitoring Program (AQMP) (Tex-499-A)* is listed in the BRSQC.

- 2.1.1.1. **Blending Class A and Class B Aggregates.** Class B aggregate meeting all other requirements in Table 1 may be blended with a Class A aggregate to meet requirements for Class A materials; however, Class B virgin (non-recycled) aggregate may be disallowed when shown on the plans. Ensure that at least 50% by weight, or volume if required, of the material retained on the No. 4 sieve comes from the Class A aggregate source when blending Class A and B aggregates to meet a Class A requirement. Blend by volume if the bulk specific gravities of the Class A and B aggregates differ by more than 0.300. Coarse aggregate from RAP and Recycled Asphalt Shingles (RAS) will be considered as Class B aggregate for blending purposes.

The Engineer may perform tests at any time during production, when the Contractor blends Class A and B aggregates to meet a Class A requirement, to ensure that at least 50% by weight, or volume if required, of the material retained on the No. 4 sieve comes from the Class A aggregate source. The Engineer will use the Department's mix design template, when electing to verify conformance, to calculate the percent of Class A aggregate retained on the No. 4 sieve by inputting the bin percentages shown from readouts in the control room at the time of production and stockpile gradations measured at the time of production. The Engineer may determine the gradations based on either washed or dry sieve analysis from samples obtained from individual aggregate cold feed bins or aggregate stockpiles. The Engineer may perform spot checks using the gradations supplied by the Contractor on the mixture design report as an input for the template; however, a failing spot check will require confirmation with a stockpile gradation determined by the Engineer.

- 2.1.1.2. **Micro-Deval Abrasion.** The Engineer will perform a minimum of one Micro-Deval abrasion test in accordance with Tex-461-A for each coarse aggregate source used in the mixture design that has a Rated Source Soundness Magnesium (RSSM) loss value greater than 15 as listed in the BRSQC. The Engineer will perform testing before the start of production and may perform additional testing at any time during production. The Engineer may obtain the coarse aggregate samples from each coarse aggregate source or may require the Contractor to obtain the samples. The Engineer may waive all Micro-Deval testing based on a satisfactory test history of the same aggregate source.

The Engineer will estimate the magnesium sulfate soundness loss for each coarse aggregate source, when tested, using the following formula:

$$Mg_{est.} = (RSSM)(MD_{act.}/RSMD)$$

where:

$Mg_{est.}$ = magnesium sulfate soundness loss

$MD_{act.}$ = actual Micro-Deval percent loss

$RSMD$ = Rated Source Micro-Deval

When the estimated magnesium sulfate soundness loss is greater than the maximum magnesium sulfate soundness loss specified, the coarse aggregate source will not be allowed for use unless otherwise approved. The Engineer will consult the Geotechnical, Soils, and Aggregates Branch of the Construction Division and additional testing may be required before granting approval.

- 2.1.2. **Intermediate Aggregate.** Aggregates not meeting the definition of coarse or fine aggregate will be defined as intermediate aggregate. Supply intermediate aggregates, when used that are free from organic impurities. The Engineer may test the intermediate aggregate in accordance with Tex-408-A to verify the material is free from organic impurities. Supply intermediate aggregate from coarse aggregate sources, when used that meet the requirements shown in Table 1 unless otherwise approved.

Test the stockpile if 10% or more of the stockpile is retained on the No. 4 sieve, and verify that it meets the requirements in Table 1 for crushed face count (Tex-460-A) and flat and elongated particles (Tex-280-F).

- 2.1.3. **Fine Aggregate.** Fine aggregates consist of manufactured sands, screenings, and field sands. Fine aggregate stockpiles must meet the gradation requirements in Table 2. Supply fine aggregates that are free from organic impurities. The Engineer may test the fine aggregate in accordance with Tex-408-A to verify the

material is free from organic impurities. No more than 15% of the total aggregate may be field sand or other uncrushed fine aggregate. Use fine aggregate, with the exception of field sand, from coarse aggregate sources that meet the requirements shown in Table 1 unless otherwise approved.

Test the stockpile if 10% or more of the stockpile is retained on the No. 4 sieve and verify that it meets the requirements in Table 1 for crushed face count (Tex-460-A) and flat and elongated particles (Tex-280-F).

Table 1
Aggregate Quality Requirements

Property	Test Method	Requirement
Coarse Aggregate		
SAC	Tex-499-A (AQMP)	As shown on the plans
Deleterious material, %, Max	Tex-217-F, Part I	1.0
Decantation, %, Max	Tex-217-F, Part II	1.5
Micro-Deval abrasion, %	Tex-461-A	Note ¹
Los Angeles abrasion, %, Max	Tex-410-A	30
Magnesium sulfate soundness, 5 cycles, %, Max	Tex-411-A	20
Crushed face count, ² %, Min	Tex-460-A, Part I	95
Flat and elongated particles @ 5:1, %, Max	Tex-280-F	10
Fine Aggregate		
Linear shrinkage, %, Max	Tex-107-E	3
Combined Aggregate³		
Sand equivalent, %, Min	Tex-203-F	45

- Used to estimate the magnesium sulfate soundness loss in accordance with Section 346.2.1.1.2., "Micro-Deval Abrasion."
- Only applies to crushed gravel.
- Aggregates, without mineral filler, RAP, RAS, or additives, combined as used in the job-mix formula (JMF).

Table 2
Gradation Requirements for Fine Aggregate

Sieve Size	% Passing by Weight or Volume
3/8-in.	100
#8	70–100
#200	0–30

- 2.2. **Mineral Filler.** Mineral filler consists of finely divided mineral matter such as agricultural lime, crusher fines, hydrated lime, or fly ash. Mineral filler is allowed unless otherwise shown on the plans. Use no more than 2% hydrated lime unless otherwise shown on the plans. Use no more than 5% fly ash unless otherwise shown on the plans. Test all mineral fillers except hydrated lime and fly ash in accordance with Tex-107-E to ensure specification compliance. The plans may require or disallow specific mineral fillers. Provide mineral filler, when used, that:

- is sufficiently dry, free-flowing, and free from clumps and foreign matter as determined by the Engineer;
- does not exceed 3% linear shrinkage when tested in accordance with Tex-107-E; and
- meets the gradation requirements in Table 3.

Table 3
Gradation Requirements for Mineral Filler

Sieve Size	% Passing by Weight or Volume
#8	100
#200	55–100

- 2.3. **Baghouse Fines.** Fines collected by the baghouse or other dust-collecting equipment may be reintroduced into the mixing drum.
- 2.4. **Asphalt Binder.** Furnish the type and grade of binder specified on the plans that meets the requirements of Item 300, "Asphalts, Oils, and Emulsions."

- 2.4.1. **Performance-Graded (PG) Binder.** When SMA is specified, provide an asphalt binder with a high-temperature grade of PG 76 and low-temperature grade as shown on the plans in accordance with Section 300.2.10., "Performance-Graded Binders."
- 2.4.2. **Asphalt-Rubber (A-R) Binder.** When SMAR is specified, provide A-R binder that meets the Type I or Type II requirements of Section 300.2.9., "Asphalt-Rubber Binders," unless otherwise shown on the plans. Use at least 15.0% by weight of Crumb Rubber Modifier (CRM) that meets the Grade B or Grade C requirements of Section 300.2.7., "Crumb Rubber Modifier," unless otherwise shown on the plans. Provide the Engineer the A-R binder blend design with the mix design (JMF1) submittal. Provide the Engineer with documentation such as the bill of lading showing the quantity of CRM used in the project unless otherwise directed.
- 2.5. **Tack Coat.** Furnish CSS-1H, SS-1H, or a PG binder with a minimum high-temperature grade of PG 58 for tack coat binder in accordance with Item 300, "Asphalts, Oils, and Emulsions." Specialized or preferred tack coat materials may be allowed or required when shown on the plans. Do not dilute emulsified asphalts at the terminal, in the field, or at any other location before use.

The Engineer will obtain at least one sample of the tack coat binder per project in accordance with Tex-500-C, Part III, and test it to verify compliance with Item 300, "Asphalts, Oils, and Emulsions." The Engineer will obtain the sample from the asphalt distributor immediately before use.

- 2.6. **Additives.** Use the type and rate of additive specified when shown on the plans. Additives that facilitate mixing, compaction, or improve the quality of the mixture are allowed when approved. Provide the Engineer with documentation such as the bill of lading showing the quantity of additives used in the project unless otherwise directed.

- 2.6.1. **Fibers.** Provide cellulose or mineral fibers when PG binder is specified. Submit written certification to the Engineer that the fibers proposed for use meet the requirements of DMS-9204, "Fiber Additives for Bituminous Mixtures." Fibers may be pre-blended into the binder at the asphalt supply terminal unless otherwise shown on the plans.

When at least 3% RAS is used in the mixture, the Contractor may reduce the amount of fibers as specified in Note 2 of Table 8.

- 2.6.2. **Lime and Liquid Antistripping Agent.** When lime or a liquid antistripping agent is used, add in accordance with Item 301, "Asphalt Antistripping Agents." Do not add lime directly into the mixing drum of any plant where lime is removed through the exhaust stream unless the plant has a baghouse or dust collection system that reintroduces the lime into the drum.

- 2.6.3. **Warm Mix Asphalt (WMA).** Warm Mix Asphalt (WMA) is defined as HMA that is produced within a target temperature discharge range of 215°F and 275°F using approved WMA additives or processes from the Department's MPL.

WMA is allowed for use on all projects and is required when shown on the plans. When WMA is required, the maximum placement or target discharge temperature for WMA will be set at a value below 275°F.

Department-approved WMA additives or processes may be used to facilitate mixing and compaction of HMA produced at target discharge temperatures above 275°F; however, such mixtures will not be defined as WMA.

- 2.7. **Recycled Materials.** Use of RAP and RAS is permitted unless otherwise shown on the plans. Do not exceed the maximum allowable percentages of RAP and RAS shown in Table 4. The allowable percentages shown in Table 4 may be decreased or increased when shown on the plans. Determine asphalt binder content and gradation of the RAP and RAS stockpiles for mixture design purposes in accordance with Tex-236-F. The Engineer may verify the asphalt binder content of the stockpiles at any time during production. Perform other tests on RAP and RAS when shown on the plans. Asphalt binder from RAP and RAS is designated as recycled asphalt binder. Calculate and ensure that the ratio of the recycled asphalt binder to total binder does

not exceed the percentages shown in Table 4 during mixture design and HMA production when RAP or RAS is used. Use a separate cold feed bin for each stockpile of RAP and RAS during HMA production.

Surface and non-surface mixes referenced in Table 4 are defined as follows:

- **Surface.** The final HMA lift placed at or near the top of the pavement structure; and
- **Non-Surface.** Mixtures placed below an HMA surface mix.

- 2.7.1. **RAP.** RAP is salvaged, milled, pulverized, broken, or crushed asphalt pavement. Crush or break RAP so that 100% of the particles pass the 2 in. sieve. Fractionated RAP is defined as 2 or more RAP stockpiles, divided into coarse and fine fractions.

Use of Contractor-owned RAP including HMA plant waste is permitted unless otherwise shown on the plans. Department-owned RAP stockpiles are available for the Contractor's use when the stockpile locations are shown on the plans. If Department-owned RAP is available for the Contractor's use, the Contractor may use Contractor-owned fractionated RAP and replace it with an equal quantity of Department-owned RAP. Unfractionated RAP is not allowed in SMA and SMAR mixtures. Department-owned RAP generated through required work on the Contract is available for the Contractor's use when shown on the plans. Perform any necessary tests to ensure Contractor- or Department-owned RAP is appropriate for use. The Department will not perform any tests or assume any liability for the quality of the Department-owned RAP unless otherwise shown on the plans. The Contractor will retain ownership of RAP generated on the project when shown on the plans.

The coarse RAP stockpile will contain only material retained by processing over a 3/8-in. or 1/2-in. screen unless otherwise approved. The fine RAP stockpile will contain only material passing the 3/8-in. or 1/2-in. screen unless otherwise approved. The Engineer may allow the Contractor to use an alternate to the 3/8-in. or 1/2-in. screen to fractionate the RAP. The maximum percentages of fractionated RAP may be comprised of coarse or fine fractionated RAP or the combination of both coarse and fine fractionated RAP.

Do not use Department- or Contractor-owned RAP contaminated with dirt or other objectionable materials. Do not use Department- or Contractor-owned RAP if the decantation value exceeds 5% and the plasticity index is greater than 8. Test the stockpiled RAP for decantation in accordance with Tex-406-A, Part I. Determine the plasticity index in accordance with Tex-106-E if the decantation value exceeds 5%. The decantation and plasticity index requirements do not apply to RAP samples with asphalt removed by extraction or ignition.

Do not intermingle Contractor-owned RAP stockpiles with Department-owned RAP stockpiles. Remove unused Contractor-owned RAP material from the project site upon completion of the project. Return unused Department-owned RAP to the designated stockpile location.

- 2.7.2. **RAS.** Use of post-manufactured RAS or post-consumer RAS (tear-offs) is permitted unless otherwise shown on the plans. RAS is defined as processed asphalt shingle material from manufacturing of asphalt roofing shingles or from re-roofing residential structures. Post-manufactured RAS is processed manufacturer's shingle scrap by-product. Post-consumer RAS is processed shingle scrap removed from residential structures. Comply with all regulatory requirements stipulated for RAS by the TCEQ. RAS may be used separately or in conjunction with RAP.

Process the RAS by ambient grinding or granulating such that 100% of the particles pass the 3/8 in. sieve when tested in accordance with Tex-200-F, Part I. Perform a sieve analysis on processed RAS material before extraction (or ignition) of the asphalt binder.

Add sand meeting the requirements of Table 1 and Table 2 or fine RAP to RAS stockpiles if needed to keep the processed material workable. Any stockpile that contains RAS will be considered a RAS stockpile and be limited to no more than 5.0% of the HMA mixture in accordance with Table 4.

Certify compliance of the RAS with DMS-11000, "Evaluating and Using Nonhazardous Recyclable Materials Guidelines." Treat RAS as an established nonhazardous recyclable material if it has not come into contact

with any hazardous materials. Use RAS from shingle sources on the Department's MPL. Remove substantially all materials before use that are not part of the shingle, such as wood, paper, metal, plastic, and felt paper. Determine the deleterious content of RAS material for mixture design purposes in accordance with Tex-217-F, Part III. Do not use RAS if deleterious materials are more than 0.5% of the stockpiled RAS unless otherwise approved. Submit a sample for approval before submitting the mixture design. The Department will perform the testing for deleterious material of RAS to determine specification compliance.

Table 4
Maximum Allowable Amounts of Recycled Binder, RAP, and RAS

Mixture Description & Location	Maximum Ratio of Recycled Binder to Total Binder ¹ (%)	Maximum Allowable Recycled Material ² (%)	
		Fractionated RAP ³	RAS ⁴
Surface	15.0	15.0	5.0
Non-Surface	20.0	20.0	5.0

1. Combined recycled binder from fractionated RAP and RAS.
2. Unfractionated RAP is not allowed in SMA or SMAR mixtures.
3. May replace up to 5% fractionated RAP with RAS.
4. May be used separately or as a replacement for no more than 5% of the allowable fractionated RAP.

3. EQUIPMENT

Provide required or necessary equipment in accordance with Item 320, "Equipment for Asphalt Concrete Pavement." When A-R binder is specified, equip the hot-mix plant with an in-line viscosity-measuring device located between the blending unit and the mixing drum. Provide a means to calibrate the asphalt mass flow meter on-site when a meter is used.

4. CONSTRUCTION

Produce, haul, place, and compact the specified paving mixture. In addition to tests required by the specification, Contractors may perform other QC tests as deemed necessary. At any time during the project, the Engineer may perform production and placement tests as deemed necessary in accordance with Item 5, "Control of the Work." Schedule and participate in a mandatory pre-paving meeting with the Engineer on or before the first day of paving unless otherwise shown on the plans.

- 4.1. **Certification.** Personnel certified by the Department-approved hot-mix asphalt certification program must conduct all mixture designs, sampling, and testing in accordance with Table 5. Supply the Engineer with a list of certified personnel and copies of their current certificates before beginning production and when personnel changes are made. Provide a mixture design developed and signed by a Level 2 certified specialist. Provide Level 1A certified specialists at the plant during production operations. Provide Level 1B certified specialists to conduct placement tests.

Table 5
Test Methods, Test Responsibility, and Minimum Certification Levels

Test Description	Test Method	Contractor	Engineer	Level ¹
1. Aggregate and Recycled Material Testing				
Sampling	Tex-221-F	✓	✓	1A
Dry sieve	Tex-200-F, Part I	✓	✓	1A
Washed sieve	Tex-200-F, Part II	✓	✓	1A
Deleterious material	Tex-217-F, Parts I & III	✓	✓	1A
Decantation	Tex-217-F, Part II	✓	✓	1A
Los Angeles abrasion	Tex-410-A		✓	TxDOT
Magnesium sulfate soundness	Tex-411-A		✓	TxDOT
Micro-Deval abrasion	Tex-461-A		✓	2
Crushed face count	Tex-460-A	✓	✓	2
Flat and elongated particles	Tex-280-F	✓	✓	2
Linear shrinkage	Tex-107-E	✓	✓	2
Sand equivalent	Tex-203-F	✓	✓	2
Organic impurities	Tex-408-A	✓	✓	2
2. Asphalt Binder & Tack Coat Sampling				
Asphalt binder sampling	Tex-500-C, Part II	✓	✓	1A/1B
Tack coat sampling	Tex-500-C, Part III	✓	✓	1A/1B
3. Mix Design & Verification				
Design and JMF changes	Tex-204-F	✓	✓	2
Mixing	Tex-205-F	✓	✓	2
Molding (SGC)	Tex-241-F	✓	✓	1A
Laboratory-molded density	Tex-207-F	✓	✓	1A
VMA ² (calculation only)	Tex-204-F	✓	✓	2
Rice gravity	Tex-227-F	✓	✓	1A
Ignition oven correction factors ³	Tex-236-F	✓	✓	2
Drain-down	Tex-235-F	✓	✓	1A
Hamburg Wheel test	Tex-242-F	✓	✓	2
Overlay test	Tex-248-F		✓	TxDOT
Boil test	Tex-530-C	✓	✓	1A
4. Production Testing				
Selecting production random numbers	Tex-225-F, Part I		✓	1A
Mixture sampling	Tex-222-F	✓	✓	1A
Molding (SGC)	Tex-241-F	✓	✓	1A
Laboratory-molded density	Tex-207-F	✓	✓	1A
VMA ² (calculation only)	Tex-204-F	✓	✓	1A
Rice gravity	Tex-227-F	✓	✓	1A
Gradation & asphalt binder content ³	Tex-236-F	✓	✓	1A
Control charts	Tex-233-F	✓	✓	1A
Moisture content	Tex-212-F	✓	✓	1A
Hamburg Wheel test	Tex-242-F	✓	✓	2
Micro-Deval abrasion	Tex-461-A		✓	2
Drain-down	Tex-235-F	✓	✓	1A
Boil test	Tex-530-C	✓	✓	1A
Abson recovery	Tex-211-F		✓	TxDOT
Overlay test	Tex-248-F		✓	TxDOT
Cantabro loss	Tex-245-F		✓	2
5. Placement Testing				
Selecting placement random numbers	Tex-225-F, Part II		✓	1A/1B
Trimming roadway cores	Tex-207-F	✓	✓	1A/1B
In-place air voids	Tex-207-F	✓	✓	1A/1B
Establish rolling pattern	Tex-207-F	✓	✓	1B
Control charts	Tex-233-F	✓	✓	1A
Ride quality measurement	Tex-1001-S	✓	✓	Note ⁴
Segregation (density profile)	Tex-207-F, Part V	✓	✓	1B
Longitudinal joint density	Tex-207-F, Part VII	✓	✓	1B
Thermal profile	Tex-244-F	✓	✓	1B

1. Level 1A, 1B, and 2 are certification levels provided by the Hot Mix Asphalt Center certification program.

2. Voids in mineral aggregates.

3. Refer to Section 346.4.9.2.3., "Production Testing," for exceptions to using an ignition oven.

4. Profiler and operator are required to be certified at the Texas A&M Transportation Institute facility when Surface Test Type B is specified.

4.2.

Reporting and Responsibilities. Use Department-provided templates to record and calculate all test data, including mixture design, production and placement QC/QA, control charts, thermal profiles, segregation

density profiles, and longitudinal joint density. Obtain the current version of the templates at <http://www.txdot.gov/inside-txdot/forms-publications/consultants-contractors/forms/site-manager.html> or from the Engineer. The Engineer and the Contractor will provide any available test results to the other party when requested. The maximum allowable time for the Contractor and Engineer to exchange test data is as given in Table 6 unless otherwise approved. The Engineer and the Contractor will immediately report to the other party any test result that requires suspension of production or placement, a payment adjustment less than 1.000, or that fails to meet the specification requirements. Record and electronically submit all test results and pertinent information on Department-provided templates.

Subsequent sublots placed after test results are available to the Contractor, which require suspension of operations, may be considered unauthorized work. Unauthorized work will be accepted or rejected at the discretion of the Engineer in accordance with Article 5.3., "Conformity with Plans, Specifications, and Special Provisions."

Table 6
Reporting Schedule

Description	Reported By	Reported To	To Be Reported Within
<i>Production Quality Control</i>			
Gradation ¹	Contractor	Engineer	1 working day of completion of the subplot
Asphalt binder content ¹			
Laboratory-molded density ²			
Moisture content ³			
Boil test ³			
<i>Production Quality Assurance</i>			
Gradation ³	Engineer	Contractor	1 working day of completion of the subplot
Asphalt binder content ³			
Laboratory-molded density ¹			
Hamburg Wheel test ²			
Boil test ³			
Binder tests ²			
<i>Placement Quality Control</i>			
In-place air voids ²	Contractor	Engineer	1 working day of completion of the lot
Segregation ¹			
Longitudinal joint density ¹			
Thermal profile ¹			
<i>Placement Quality Assurance</i>			
In-place air voids ¹	Engineer	Contractor	1 working day of receipt of the trimmed cores for in-place air voids ⁴
Segregation ²			
Longitudinal joint density ²			
Thermal profile ²			
Aging ratio ²			
Payment adjustment summary	Engineer	Contractor	2 working days of performing all required tests and receiving Contractor test data

1. These tests are required on every subplot.
2. Optional test. To be reported as soon as results become available.
3. To be performed at the frequency specified on the plans.
4. 2 days are allowed if cores cannot be dried to constant weight within 1 day.

The Engineer will use the Department-provided template to calculate all payment adjustment factors for the lot. Sublot samples may be discarded after the Engineer and Contractor sign off on the payment adjustment summary documentation for the lot.

Use the procedures described in Tex-233-F to plot the results of all quality control (QC) and quality assurance (QA) testing. Update the control charts as soon as test results for each subplot become available. Make the control charts readily accessible at the field laboratory. The Engineer may suspend production for failure to update control charts.

- 4.3. **Quality Control Plan (QCP).** Develop and follow the QCP in detail. Obtain approval for changes to the QCP made during the project. The Engineer may suspend operations if the Contractor fails to comply with the QCP.

Submit a written QCP before the mandatory pre-paving meeting. Receive approval of the QCP before beginning production. Include the following items in the QCP:

- 4.3.1. **Project Personnel.** For project personnel, include:
- a list of individuals responsible for QC with authority to take corrective action;
 - current contact information for each individual listed; and
 - current copies of certification documents for individuals performing specified QC functions.
- 4.3.2. **Material Delivery and Storage.** For material delivery and storage, include:
- the sequence of material processing, delivery, and minimum quantities to assure continuous plant operations;
 - aggregate stockpiling procedures to avoid contamination and segregation;
 - frequency, type, and timing of aggregate stockpile testing to assure conformance of material requirements before mixture production; and
 - procedure for monitoring the quality and variability of asphalt binder.
- 4.3.3. **Production.** For production, include:
- loader operation procedures to avoid contamination in cold bins;
 - procedures for calibrating and controlling cold feeds;
 - procedures to eliminate debris or oversized material;
 - procedures for adding and verifying rates of each applicable mixture component (e.g., aggregate, asphalt binder, RAP, RAS, lime, liquid antistriper, WMA, fibers);
 - procedures for reporting job control test results; and
 - procedures to avoid segregation and drain-down in the silo.
- 4.3.4. **Loading and Transporting.** For loading and transporting, include:
- type and application method for release agents; and
 - truck loading procedures to avoid segregation.
- 4.3.5. **Placement and Compaction.** For placement and compaction, include:
- proposed agenda for mandatory pre-paving meeting, including date and location;
 - proposed paving plan (e.g., paving widths, joint offsets, and lift thicknesses);
 - type and application method for release agents in the paver and on rollers, shovels, lutes, and other utensils;
 - procedures for the transfer of mixture into the paver while avoiding segregation and preventing material spillage;
 - process to balance production, delivery, paving, and compaction to achieve continuous placement operations and good ride quality;
 - paver operations (e.g., operation of wings, height of mixture in auger chamber) to avoid physical and thermal segregation and other surface irregularities; and
 - procedures to construct quality longitudinal and transverse joints.
- 4.4. **Mixture Design.**
- 4.4.1. **Design Requirements.** Use the SMA design procedure provided in Tex-204-F, unless otherwise shown on the plans. Design the mixture to meet the requirements listed in Tables 1, 2, 3, 4, 7, 8, and 9.

Design SMA or SMAR mixtures using a Superpave Gyrotory Compactor (SGC) at 50 gyrations as the design number of gyrations (Ndesign). The Ndesign level may be reduced to no less than 35 gyrations at the Contractor's discretion.

Use an approved laboratory from the Department's MPL to perform the Hamburg Wheel test, and provide results with the mixture design, or provide the laboratory mixture and request that the Department perform the Hamburg Wheel test. Provide laboratory mixture and request that the Department perform the Overlay test. The Engineer will be allowed 10 working days to provide the Contractor with Hamburg Wheel and Overlay test results on the laboratory mixture design.

The Engineer will provide the mixture design when shown on the plans. The Contractor may submit a new mixture design at any time during the project. The Engineer will verify and approve all mixture designs (JMF1) before the Contractor can begin production.

Provide the Engineer with a mixture design report using the Department-provided template. Include the following items in the report:

- the combined aggregate gradation, source, specific gravity, and percent of each material used;
- asphalt binder content and aggregate gradation of RAP and RAS stockpiles;
- the Ndesign level used;
- results of all applicable tests;
- the mixing and molding temperatures;
- the signature of the Level 2 person or persons that performed the design;
- the date the mixture design was performed; and
- a unique identification number for the mixture design.

Table 7
Master Gradation Limits (% Passing by Weight or Volume) and VMA Requirements

Sieve Size	SMA-C Coarse	SMA-D Medium	SMA-F Fine	SMAR-C Coarse	SMAR-F Fine
3/4-in.	100.0 ¹	100.0 ¹	–	100.0 ¹	–
1/2-in.	80.0–90.0	85.0–99.0	100.0 ¹	72.0–85.0	100.0 ¹
3/8-in.	25.0–60.0	50.0–75.0	70.0–100.0	50.0–70.0	95.0–100.0
#4	20.0–28.0	20.0–32.0	30.0–60.0	30.0–45.0	40.0–50.0
#8	14.0–20.0	16.0–28.0	20.0–40.0	17.0–27.0	17.0–27.0
#16	8.0–20.0	8.0–28.0	6.0–30.0	12.0–22.0	12.0–22.0
#30	8.0–20.0	8.0–28.0	6.0–30.0	8.0–20.0	8.0–20.0
#50	8.0–20.0	8.0–28.0	6.0–30.0	6.0–15.0	6.0–15.0
#200	8.0–12.0	8.0–12.0	4.0–12.0	5.0–9.0	5.0–9.0
Design VMA, % Min					
	17.5	17.5	17.5	19.0	19.0
Production (Plant-Produced) VMA, % Min					
	17.0	17.0	17.0	18.5	18.5

1. Defined as maximum sieve size. No tolerance allowed.

Table 8
Laboratory Mixture Design Properties

Mixture Property	SMA Mixtures	SMAR Mixtures	Test Procedure
Design gyrations, (N _{design}) ¹	50	50	Tex-241-F
Target laboratory-molded density, %	96.0	96.0	Tex-207-F
Asphalt binder content, %	6.0-7.0	7.0-10.0	–
Drain-down, %	0.10 Max	0.10 Max	Tex-235-F
Fiber content, % by wt. of total mixture	0.20 ² -0.50	–	Calculated
CRM content, % by wt. of A-R binder	–	15.0 Min	Calculated
Hamburg Wheel test, ³ rut depth @ 20,000 passes tested @ 50°C, mm	12.5 Max	12.5 Max	Tex-242-F
Overlay test, number of cycles	200 Min	200 Min	Tex-248-F
Boil test ⁴	–	–	Tex-530-C

1. Adjust within a range of 35–100 gyrations when shown on the plans or specification or when mutually agreed between the Engineer and Contractor.
2. When at least 3% RAS is used in the mixture, the Contractor may reduce the amount of fibers to no less than 0.10% provided the mixture meets the drain-down requirement.
3. For SMAR mixes, the number of passes required for the Hamburg Wheel test may be decreased. Other tests may be required for SMAR mixes instead of, or in addition to, the Hamburg Wheel test when shown on the plans.
4. Used to establish baseline for comparison to production results. May be waived when approved.

4.4.2. **Job-Mix Formula Approval.** The job-mix formula (JMF) is the combined aggregate gradation, N_{design} level, and target asphalt percentage used to establish target values for hot-mix production. JMF1 is the original laboratory mixture design used to produce the trial batch. When WMA is used, JMF1 may be designed and submitted to the Engineer without including the WMA additive. When WMA is used, document the additive or process used and recommended rate on the JMF1 submittal. The Engineer and the Contractor will verify JMF1 based on plant-produced mixture from the trial batch unless otherwise approved. The Engineer may accept an existing mixture design previously used on a Department project and may waive the trial batch to verify JMF1. The Department may require the Contractor to reimburse the Department for verification tests if more than 2 trial batches per design are required.

4.4.2.1. **Contractor's Responsibilities.**

4.4.2.1.1. **Providing Superpave Gyrotory Compactor.** Furnish an SGC calibrated in accordance with Tex-241-F for molding production samples. Locate the SGC at the Engineer's field laboratory and make the SGC available to the Engineer for use in molding production samples.

4.4.2.1.2. **Gyrotory Compactor Correlation Factors.** Use Tex-206-F, Part II, to perform a gyrotory compactor correlation when the Engineer uses a different SGC. Apply the correlation factor to all subsequent production test results.

4.4.2.1.3. **Submitting JMF1.** Furnish a mix design report (JMF1) with representative samples of all component materials and request approval to produce the trial batch. Provide approximately 25,000 g of the laboratory mixture and request the Department perform the Overlay test. Provide an additional 10,000 g of the design mixture if opting to have the Department perform the Hamburg Wheel test on the laboratory mixture, and request that the Department perform the test.

4.4.2.1.4. **Supplying Aggregates.** Provide approximately 40 lb. of each aggregate stockpile unless otherwise directed.

4.4.2.1.5. **Supplying Asphalt.** Provide at least 1 gal. of the asphalt material and sufficient quantities of any additives proposed for use.

4.4.2.1.6. **Ignition Oven Correction Factors.** Determine the aggregate and asphalt correction factors from the ignition oven in accordance with Tex-236-F. Note that the asphalt content correction factor takes into account the percent fibers in the mixture so that the fibers are excluded from the binder content determination. Provide the Engineer with split samples of the mixtures, before the trial batch production, including all additives (except water), and blank samples used to determine the correction factors for the ignition oven used for QA testing during production. Correction factors established from a previously approved mixture design may be

used for the current mixture design, if the mixture design and ignition oven are the same as previously used unless otherwise directed.

- 4.4.2.1.7. **Boil Test.** Perform the test and retain the tested sample from Tex-530-C until completion of the project or as directed. Use this sample for comparison purposes during production. The Engineer may waive the requirement for the boil test.
- 4.4.2.1.8. **Trial Batch Production.** Provide a plant-produced trial batch upon receiving conditional approval of JMF1 and authorization to produce a trial batch, including the WMA additive or process if applicable, for verification testing of JMF1 and development of JMF2. Produce a trial batch mixture that meets the requirements in Table 4 and Table 9. The Engineer may accept test results from recent production of the same mixture instead of a new trial batch.
- 4.4.2.1.9. **Trial Batch Production Equipment.** Use only equipment and materials proposed for use on the project to produce the trial batch. Provide documentation to verify the calibration or accuracy of the asphalt mass flow meter to measure the binder content. Verify that asphalt mass flow meter meets the requirements of 0.4% accuracy, when required, in accordance with Item 520, "Weighing and Measuring Equipment." The Engineer may require that the accuracy of the mass flow meter be verified based on quantities used.
- 4.4.2.1.10. **Trial Batch Quantity.** Produce enough quantity of the trial batch to ensure that the mixture meets the specification requirements.
- 4.4.2.1.11. **Number of Trial Batches.** Produce trial batches as necessary to obtain a mixture that meets the specification requirements.
- 4.4.2.1.12. **Trial Batch Sampling.** Obtain a representative sample of the trial batch and split it into 3 equal portions in accordance with Tex-222-F. Label these portions as "Contractor," "Engineer," and "Referee." Deliver samples to the appropriate laboratory as directed.
- 4.4.2.1.13. **Trial Batch Testing.** Test the trial batch to ensure the mixture produced using the proposed JMF1 meets the mixture requirements in Table 9. Ensure the trial batch mixture is also in compliance with the Hamburg Wheel requirement in Table 8. Use a Department-approved laboratory to perform the Hamburg Wheel test on the trial batch mixture or request that the Department perform the Hamburg Wheel test. The Engineer will be allowed 10 working days to provide the Contractor with Hamburg Wheel test results on the trial batch. Provide the Engineer with a copy of the trial batch test results.
- 4.4.2.1.14. **Development of JMF2.** Evaluate the trial batch test results after the Engineer grants full approval of JMF1 based on results from the trial batch, determine the optimum mixture proportions, and submit as JMF2. Adjust the asphalt binder content or gradation to achieve the specified target laboratory-molded density. The asphalt binder content established for JMF2 is not required to be within any tolerance of the optimum asphalt binder content established for JMF1; however, mixture produced using JMF2 must meet the voids in mineral aggregates (VMA) requirements for production shown in Table 7. If the optimum asphalt binder content for JMF2 is more than 0.5% lower than the optimum asphalt binder content for JMF1, the Engineer may perform Tex-248-F on Lot 1 to confirm the mixture meets the Overlay test requirement of 200 cycles. Verify that JMF2 meets the mixture requirements in Table 4.
- 4.4.2.1.15. **Mixture Production.** Use JMF2 to produce Lot 1 as described in Section 346.4.9.3.1.1., "Lot 1 Placement," after receiving approval for JMF2 and a passing result from the Department's or a Department-approved laboratory's Hamburg Wheel test on the trial batch. If desired, proceed to Lot 1 production, once JMF2 is approved, at the Contractor's risk without receiving the results from the Department's Hamburg Wheel test on the trial batch.

Notify the Engineer if electing to proceed without Hamburg Wheel test results from the trial batch. Note that the Engineer may require up to the entire subplot of any mixture failing the Hamburg Wheel test be removed and replaced at the Contractor's expense.

4.4.2.1.16. **Development of JMF3.** Evaluate the test results from Lot 1, determine the optimum mixture proportions, and submit as JMF3 for use in Lot 2.

4.4.2.1.17. **JMF Adjustments.** If JMF adjustments are necessary to achieve the specified requirements, make the adjustments before beginning a new lot. The adjusted JMF must:

- be provided to the Engineer in writing before the start of a new lot;
- be numbered in sequence to the previous JMF;
- meet the mixture requirements in Table 4;
- meet the master gradation limits shown in Table 7; and
- be within the operational tolerances of JMF2 listed in Table 9.

4.4.2.1.18. **Requesting Referee Testing.** Use referee testing, if needed, in accordance with Section 346.4.9.1., "Referee Testing," to resolve testing differences with the Engineer.

Table 9
Operational Tolerances

Description	Test Method	Allowable Difference Between Trial Batch and JMF1 Target	Allowable Difference from Current JMF Target	Allowable Difference between Contractor and Engineer ¹
Individual % retained for #8 sieve and larger	Tex-200-F or Tex-236-F	Must be within Master Grading Limits in Table 7	±5.0 ^{2,3}	±5.0
Individual % retained for sieves smaller than #8 and larger than #200			±3.0 ^{2,3}	±3.0
% passing the #200 sieve			±2.0 ^{2,3}	±1.6
Asphalt binder content, %	Tex-236-F ⁴	±0.5	±0.3 ³	±0.3
Laboratory-molded density, %	Tex-207-F	±1.0	±1.0	±0.5
In-place air voids, %		N/A	N/A	±1.0
Laboratory-molded bulk specific gravity		N/A	N/A	±0.020
VMA, % Min	Tex-204-F	Note ⁵	Note ⁵	N/A
Theoretical maximum specific (Rice) gravity	Tex-227-F	N/A	N/A	±0.020
Drain-down	Tex-235-F	Note ⁶	Note ⁶	Note ⁶

1. Contractor may request referee testing only when values exceed these tolerances.
2. When within these tolerances, mixture production gradations may fall outside the master grading limits; however, the % passing the #200 will be considered out of tolerance when outside the master grading limits.
3. Only applies to mixture produced for Lot 1 and higher.
4. Ensure the asphalt binder content determination excludes fibers. Add the recycled binder content to the flow meter readout when the asphalt mass flow meter is used to determine binder content.
5. Test and verify that Table 7 requirements are met for VMA.
6. Test and verify that Table 8 requirements are met for drain-down.

4.4.2.2. **Engineer's Responsibilities.**

4.4.2.2.1. **Gyratory Compactor.** The Engineer will use a Department SGC, calibrated in accordance with Tex-241-F, to mold samples for laboratory mixture design verification. For molding trial batch and production specimens, the Engineer will use the Contractor-provided SGC at the field laboratory or provide and use a Department SGC at an alternate location. The Engineer will make the Contractor-provided SGC in the Department field laboratory available to the Contractor for molding verification samples.

4.4.2.2.2. **Conditional Approval of JMF1 and Authorizing Trial Batch.** The Engineer will review and verify conformance of the following information within 2 working days of receipt:

- the Contractor's mix design report (JMF1);
- the Department-provided Overlay test results;
- the Contractor-provided Hamburg Wheel test results;

- all required materials including aggregates, asphalt, additives, and recycled materials; and
- the mixture specifications.

The Engineer will grant the Contractor conditional approval of JMF1 if the information provided on the paper copy of JMF1 indicates that the Contractor's mixture design meets the specifications. When the Contractor does not provide Hamburg Wheel test results with laboratory mixture design, 10 working days are allowed for conditional approval of JMF1. The Engineer will base full approval of JMF1 on the test results on mixture from the trial batch.

Unless waived, the Engineer will determine the Micro-Deval abrasion loss in accordance with Section 346.2.1.1.2., "Micro-Deval Abrasion." If the Engineer's test results are pending after 2 working days, conditional approval of JMF1 will still be granted within 2 working days of receiving JMF1. When the Engineer's test results become available, they will be used for specification compliance.

After conditionally approving JMF1, including either Contractor- or Department-supplied Hamburg Wheel test results, the Contractor is authorized to produce a trial batch.

- 4.4.2.2.3. **Hamburg Wheel and Overlay Testing of JMF1.** If the Contractor requests the option to have the Department perform the Hamburg Wheel test on the laboratory mixture, the Engineer will mold samples in accordance with Tex-242-F to verify compliance with the Hamburg Wheel test requirement in Table 8. The Engineer will perform the Overlay test. The Engineer will mold samples in accordance with Tex-248-F to verify compliance with the Overlay test requirements in Table 8.
- 4.4.2.2.4. **Ignition Oven Correction Factors.** The Engineer will use the split samples provided by the Contractor to determine the aggregate and asphalt correction factors for the ignition oven used for QA testing during production in accordance with Tex-236-F. The Engineer will verify that the asphalt content correction factor takes into account the percent fibers in the mixture so that the fibers are excluded from the binder content determination.
- 4.4.2.2.5. **Testing the Trial Batch.** Within 1 full working day, the Engineer will sample and test the trial batch to ensure that the mixture meets the requirements in Table 9. If the Contractor requests the option to have the Department perform the Hamburg Wheel test on the trial batch mixture, the Engineer will mold samples in accordance with Tex-242-F to verify compliance with the Hamburg Wheel test requirement in Table 8.
- The Engineer will have the option to perform the following tests on the trial batch:
- Tex-248-F to confirm the mixture meets the Overlay test requirement of 200 cycles; and
 - Tex-530-C, to retain and use for comparison purposes during production.
- 4.4.2.2.6. **Full Approval of JMF1.** The Engineer will grant full approval of JMF1 and authorize the Contractor to proceed with developing JMF2 if the Engineer's results for the trial batch meet the requirements in Table 9. The Engineer will notify the Contractor that an additional trial batch is required if the trial batch does not meet these requirements.
- 4.4.2.2.7. **Approval of JMF2.** The Engineer will approve JMF2 within one working day if the mixture meets the requirements in Table 4 and the gradation meets the master grading limits shown in Table 7. The asphalt binder content established for JMF2 is not required to be within any tolerance of the optimum asphalt binder content established for JMF1; however, mixture produced using JMF2 must meet the VMA requirements shown in Table 7. If the optimum asphalt binder content for JMF2 is more than 0.5% lower than the optimum asphalt binder content for JMF1, the Engineer may perform Tex-248-F on Lot 1 to confirm the mixture meets the Overlay test requirement of 200 cycles.
- 4.4.2.2.8. **Approval of Lot 1 Production.** The Engineer will authorize the Contractor to proceed with Lot 1 production (using JMF2) as soon as a passing result is achieved from the Department's or a Department-approved laboratory's Hamburg Wheel test on the trial batch. The Contractor may proceed at its own risk with Lot 1 production without the results from the Hamburg Wheel test on the trial batch.

If the Department's or Department-approved laboratory's sample from the trial batch fails the Hamburg Wheel test, the Engineer will suspend production until further Hamburg Wheel tests meet the specified values. The Engineer may require up to the entire subplot of any mixture failing the Hamburg Wheel test be removed and replaced at the Contractor's expense.

- 4.4.2.2.9. **Approval of JMF3 and Subsequent JMF Changes.** JMF3 and subsequent JMF changes are approved if they meet the mixture requirements shown in Table 4, the master grading limits shown in Table 7, and are within the operational tolerances of JMF2 shown in Table 9.
- 4.5. **Production Operations.** Perform a new trial batch when the plant or plant location is changed. Take corrective action and receive approval to proceed after any production suspension for noncompliance to the specification. Submit a new mix design and perform a new trial batch when the asphalt binder content of:
- any RAP stockpile used in the mix is more than 0.5% higher than the value shown on the mixture design report; or
 - RAS stockpile used in the mix is more than 2.0% higher than the value shown on the mixture design report.
- 4.5.1. **Storage and Heating of Materials.** Do not heat the asphalt binder above the temperatures specified in Item 300, "Asphalts, Oils, and Emulsions," or outside the manufacturer's recommended values. Provide the Engineer with daily records of asphalt binder and hot-mix asphalt discharge temperatures (in legible and discernible increments) in accordance with Item 320, "Equipment for Asphalt Concrete Pavement," unless otherwise directed. Do not store mixture for a period long enough to affect the quality of the mixture, nor in any case longer than 12 hr. unless otherwise approved.
- 4.5.2. **Mixing and Discharge of Materials.** Notify the Engineer of the target discharge temperature and produce the mixture within 25°F of the target. Monitor the temperature of the material in the truck before shipping to ensure that it does not exceed 350°F (or 275°F for WMA) and is not lower than 215°F. The Department will not pay for or allow placement of any mixture produced above 350°F.
- Produce WMA within the target discharge temperature range of 215°F and 275°F when WMA is required. Take corrective action any time the discharge temperature of the WMA exceeds the target discharge range. The Engineer may suspend production operations if the Contractor's corrective action is not successful at controlling the production temperature within the target discharge range. Note that when WMA is produced, it may be necessary to adjust burners to ensure complete combustion such that no burner fuel residue remains in the mixture.
- Control the mixing time and temperature so that substantially all moisture is removed from the mixture before discharging from the plant. Determine the moisture content, if requested, by oven-drying in accordance with Tex-212-F, Part II, and verify that the mixture contains no more than 0.2% of moisture by weight. Obtain the sample immediately after discharging the mixture into the truck, and perform the test promptly.
- 4.6. **Hauling Operations.** Clean all truck beds before use to ensure that mixture is not contaminated. Use a release agent shown on the Department's MPL to coat the inside bed of the truck when necessary.
- Use equipment for hauling as defined in Section 346.4.7.3.3., "Hauling Equipment." Use other hauling equipment only when allowed.
- 4.7. **Placement Operations.** Collect haul tickets from each load of mixture delivered to the project and provide the Department's copy to the Engineer approximately every hour or as directed. Use a hand-held thermal camera or infrared thermometer, when a thermal imaging system is not used, to measure and record the internal temperature of the mixture as discharged from the truck or Material Transfer Device (MTD) before or as the mix enters the paver and an approximate station number or GPS coordinates on each ticket. Calculate the daily yield and cumulative yield for the specified lift and provide to the Engineer at the end of paving operations for each day unless otherwise directed. The Engineer may suspend production if the Contractor fails to produce and provide haul tickets and yield calculations by the end of paving operations for each day.

Prepare the surface by removing raised pavement markers and objectionable material such as moisture, dirt, sand, leaves, and other loose impediments from the surface before placing mixture. Remove vegetation from pavement edges. Place the mixture to meet the typical section requirements and produce a smooth, finished surface with a uniform appearance and texture. Offset longitudinal joints of successive courses of hot-mix by at least 6 in. Place mixture so that longitudinal joints on the surface course coincide with lane lines, or as directed. Ensure that all finished surfaces will drain properly. Place the mixture at the rate or thickness shown on the plans. The Engineer will use the guidelines in Table 10 to determine the compacted lift thickness of each layer when multiple lifts are required. The thickness determined is based on the rate of 110 lb./sq. yd. for each inch of pavement unless otherwise shown on the plans.

Table 10
Compacted Lift Thickness and Required Core Height

Mixture Type	Compacted Lift Thickness Guidelines		Minimum Untrimmed Core Height (in.) Eligible for Testing
	Minimum (in.)	Maximum (in.)	
SMA-C	2.25	4.00	2.00
SMA-D	1.50	3.00	1.25
SMA-F	1.00	2.00	1.25
SMAR-C	2.00	4.00	1.75
SMAR-F	1.50	3.00	1.25

4.7.1. **Weather Conditions.**

4.7.1.1. **When Using a Thermal Imaging System.** The Contractor may pave any time the roadway is dry and the roadway surface temperature is at least 50°F; however, the Engineer may restrict the Contractor from paving surface mixtures if the ambient temperature is likely to drop below 32°F within 12 hr. of paving. Provide output data from the thermal imaging system to demonstrate to the Engineer that no recurring severe thermal segregation exists in accordance with Section 346.4.7.3.1.2., "Thermal Imaging System."

4.7.1.2. **When Not Using a Thermal Imaging System.** Place mixture when the roadway surface temperature is at or above 70°F unless otherwise approved or as shown on the plans. Measure the roadway surface temperature with a hand-held thermal camera or infrared thermometer. The Engineer may allow mixture placement to begin before the roadway surface reaches the required temperature if conditions are such that the roadway surface will reach the required temperature within 2 hr. of beginning placement operations. Place mixtures only when weather conditions and moisture conditions of the roadway surface are suitable as determined by the Engineer. The Engineer may restrict the Contractor from paving if the ambient temperature is likely to drop below 32°F within 12 hr. of paving.

4.7.2. **Tack Coat.** Clean the surface before placing the tack coat. The Engineer will set the rate between 0.04 and 0.10 gal. of residual asphalt per square yard of surface area. Apply a uniform tack coat at the specified rate unless otherwise directed. Apply the tack coat in a uniform manner to avoid streaks and other irregular patterns. Apply a thin, uniform tack coat to all contact surfaces of curbs, structures, and all joints. Allow adequate time for emulsion to break completely before placing any material. Prevent splattering of tack coat when placed adjacent to curb, gutter, and structures. Roll the tack coat with a pneumatic-tire roller to remove streaks and other irregular patterns when directed.

4.7.3. **Lay-Down Operations.**

4.7.3.1. **Thermal Profile.** Use a hand-held thermal camera or a thermal imaging system to obtain a continuous thermal profile in accordance with Tex-244-F. Thermal profiles are not applicable in areas described in Section 346.4.9.3.1.4., "Miscellaneous Areas."

4.7.3.1.1. **Thermal Segregation.**

4.7.3.1.1.1. **Moderate.** Any areas that have a temperature differential greater than 25°F, but not exceeding 50°F, are deemed as having moderate thermal segregation.

- 4.7.3.1.1.2. **Severe.** Any areas that have a temperature differential greater than 50°F are deemed as having severe thermal segregation.
- 4.7.3.1.2. **Thermal Imaging System.** Review the output results when a thermal imaging system is used, and provide the automated report described in Tex-244-F to the Engineer daily unless otherwise directed. Modify the paving process as necessary to eliminate any recurring (moderate or severe) thermal segregation identified by the thermal imaging system. The Engineer may suspend paving operations if the Contractor cannot successfully modify the paving process to eliminate recurring severe thermal segregation. Density profiles are not required and not applicable when using a thermal imaging system. Provide the Engineer with electronic copies of all daily data files that can be used with the thermal imaging system software to generate temperature profile plots upon completion of the project or as requested by the Engineer.
- 4.7.3.1.3. **Thermal Camera.** Take immediate corrective action to eliminate recurring moderate thermal segregation when a hand-held thermal camera is used. Evaluate areas with moderate thermal segregation by performing density profiles in accordance with Section 346.4.9.3.3.2., "Segregation (Density Profile)." Provide the Engineer with the thermal profile of every subplot within one working day of the completion of each lot. Report the results of each thermal profile in accordance with Section 346.4.2., "Reporting and Responsibilities." The Engineer will use a hand-held thermal camera to obtain a thermal profile at least once per project. No production or placement payment adjustments greater than 1.000 will be paid for any subplot that contains severe thermal segregation. Suspend operations and take immediate corrective action to eliminate severe thermal segregation unless otherwise directed. Resume operations when the Engineer determines that subsequent production will meet the requirements of this Section. Evaluate areas with severe thermal segregation by performing density profiles in accordance with Section 346.4.9.3.3.2., "Segregation (Density Profile)." Remove and replace the material in any areas that have both severe thermal segregation and a failing result for Segregation (Density Profile) unless otherwise directed. The subplot in question may receive a production and placement payment adjustment greater than 1.000, if applicable, when the defective material is successfully removed and replaced.
- 4.7.3.2. **Windrow Operations.** Operate windrow pickup equipment so that when hot-mix is placed in windrows, substantially all the mixture deposited on the roadbed is picked up and loaded into the paver.
- 4.7.3.3. **Hauling Equipment.** Use belly dumps, live bottom, or end dump trucks to haul and transfer mixture; however, with exception of paving miscellaneous areas, end dump trucks are only allowed when used in conjunction with an MTD with remixing capability or when a thermal imaging system is used unless otherwise allowed.
- 4.7.3.4. **Screed Heaters.** Turn off screed heaters to prevent overheating of the mat if the paver stops for more than 5 min. The Engineer may evaluate the suspect area in accordance with Section 346.4.9.3.3.4., "Recovered Asphalt Dynamic Shear Rheometer (DSR)," if the screed heater remains on for more than 5 min. while the paver is stopped.
- 4.8. **Compaction.** Compact the pavement uniformly to contain between 3.7% and 7.0% in-place air voids. Take immediate corrective action to bring the operation within 3.7% and 7.0% when the in-place air voids exceed the range of these tolerances. The Engineer will allow paving to resume when the proposed corrective action is likely to yield between 3.8% and 8.5% in-place air voids.

Obtain cores in areas placed under Exempt Production, as directed, at locations determined by the Engineer. The Engineer may test these cores and suspend operations or require removal and replacement if the in-place air voids are less than 2.7% or more than 8.0%. Areas defined in Section 346.4.9.3.1.4., "Miscellaneous Areas," are not subject to in-place air void determination.

Furnish the type, size, and number of rollers required for compaction as approved. Use a pneumatic-tire roller to seal the surface unless excessive pickup of fines occurs. Use additional rollers as required to remove any roller marks. Use only water or an approved release agent on rollers, tamps, and other compaction equipment unless otherwise directed.

Use the control strip method shown in Tex-207-F, Part IV, on the first day of production to establish the rolling pattern that will produce the desired in-place air voids unless otherwise directed.

Use tamps to thoroughly compact the edges of the pavement along curbs, headers, and similar structures and in locations that will not allow thorough compaction with rollers. The Engineer may require rolling with a trench roller on widened areas, in trenches, and in other limited areas.

Complete all compaction operations before the pavement temperature drops below 160°F unless otherwise allowed. The Engineer may allow compaction with a light finish roller operated in static mode for pavement temperatures below 160°F.

Allow the compacted pavement to cool to 160°F or lower before opening to traffic unless otherwise directed. Sprinkle the finished mat with water or limewater, when directed, to expedite opening the roadway to traffic.

- 4.9. **Acceptance Plan.** Payment adjustments for the material will be in accordance with Section 346.6., "Payment."

Sample and test the hot-mix on a lot and subplot basis. Suspend production until test results or other information indicates to the satisfaction of the Engineer that the next material produced or placed will result in pay factors of at least 1.000 if the production pay factor given in Section 346.6.1., "Production Payment Adjustment Factors," for 2 consecutive lots or the placement pay factor given in Section 346.6.2., "Placement Payment Adjustment Factors," for 2 consecutive lots is below 1.000.

- 4.9.1. **Referee Testing.** The Construction Division is the referee laboratory. The Contractor may request referee testing if a "remove and replace" condition is determined based on the Engineer's test results, or if the differences between Contractor and Engineer test results exceed the maximum allowable difference shown in Table 9 and the differences cannot be resolved. The Contractor may also request referee testing if the Engineer's test results require suspension of production and the Contractor's test results are within specification limits. Make the request within 5 working days after receiving test results and cores from the Engineer. Referee tests will be performed only on the subplot in question and only for the particular tests in question. Allow 10 working days from the time the referee laboratory receives the samples for test results to be reported. The Department may require the Contractor to reimburse the Department for referee tests if more than 3 referee tests per project are required and the Engineer's test results are closer to the referee test results than the Contractor's test results.

The Construction Division will determine the laboratory-molded density based on the molded specific gravity and the maximum theoretical specific gravity of the referee sample. The in-place air voids will be determined based on the bulk specific gravity of the cores, as determined by the referee laboratory, and the Engineer's average maximum theoretical specific gravity for the lot. With the exception of remove and replace conditions, referee test results are final and will establish payment adjustment factors for the subplot in question. The Contractor may decline referee testing and accept the Engineer's test results when the placement payment adjustment factor for any subplot results in a "remove and replace" condition. Placement sublots subject to be removed and replaced will be further evaluated in accordance with Section 346.6.2.2., "Placement Sublots Subject to Removal and Replacement."

- 4.9.2. **Production Acceptance.**

- 4.9.2.1. **Production Lot.** A production lot consists of 4 equal sublots. The default quantity for Lot 1 is 1,000 tons; however, when requested by the Contractor, the Engineer may increase the quantity for Lot 1 to no more than 4,000 tons. The Engineer will select subsequent lot sizes based on the anticipated daily production such that approximately 3 to 4 sublots are produced each day. The lot size will be between 1,000 tons and 4,000 tons. The Engineer may change the lot size before the Contractor begins any lot.

If the optimum asphalt binder content for JMF2 is more than 0.5% lower than the optimum asphalt content for JMF1, the Engineer may perform Tex-248-F on Lot 1 to confirm the mixture meets the Overlay test requirement of 200 cycles.

- 4.9.2.1.1. **Incomplete Production Lots.** If a lot is begun but cannot be completed, such as on the last day of production or in other circumstances deemed appropriate, the Engineer may close the lot. Adjust the payment for the incomplete lot in accordance with Section 346.6.1., "Production Payment Adjustment Factors." Close all lots within 5 working days, unless otherwise allowed.
- 4.9.2.2. **Production Sampling.**
- 4.9.2.2.1. **Mixture Sampling.** Obtain hot-mix samples from trucks at the plant in accordance with Tex-222-F. The sampler will split each sample into 3 equal portions in accordance with Tex-200-F and label these portions as "Contractor," "Engineer," and "Referee." The Engineer will perform or witness the sample splitting and take immediate possession of the samples labeled "Engineer" and "Referee." The Engineer will maintain the custody of the samples labeled "Engineer" and "Referee" until the Department's testing is completed.
- 4.9.2.2.1.1. **Random Sample.** At the beginning of the project, the Engineer will select random numbers for all production sublots. Determine sample locations in accordance with Tex-225-F. Take one sample for each subplot at the randomly selected location. The Engineer will perform or witness the sampling of production sublots.
- 4.9.2.2.1.2. **Blind Sample.** For one subplot per lot, the Engineer will obtain and test a "blind" sample instead of the random sample collected by the Contractor. Test either the "blind" or the random sample; however, referee testing (if applicable) will be based on a comparison of results from the "blind" sample. The location of the Engineer's "blind" sample will not be disclosed to the Contractor. The Engineer's "blind" sample may be randomly selected in accordance with Tex-225-F for any subplot or selected at the discretion of the Engineer. The Engineer will use the Contractor's split sample for sublots not sampled by the Engineer.
- 4.9.2.2.2. **Informational Cantabro Testing.** Select one random subplot from Lot 2 or higher for Cantabro testing during the first week of production. Obtain and provide the Engineer with approximately 40 lb. (18 kg) of mixture in sealed containers, boxes, or bags labeled with CSJ, mixture type, lot, and subplot number. The Engineer will ship the mixture to the Construction Division for testing. Results from this production test will not be used for specification compliance.
- 4.9.2.2.3. **Asphalt Binder Sampling.** Obtain a 1-qt. (1-gal. for A-R binder) sample of the asphalt binder for each lot of mixture produced. Obtain the sample at approximately the same time the mixture random sample is obtained. Sample from a port located immediately upstream from the mixing drum or pug mill in accordance with Tex-500-C, Part II. Label the can with the corresponding lot and subplot numbers and deliver the sample to the Engineer. The Engineer may also obtain independent samples. If obtaining an independent asphalt binder sample, the Engineer will split a sample of the asphalt binder with the Contractor. The Engineer will test at least one asphalt binder sample per project to verify compliance with Item 300, "Asphalts, Oils, and Emulsions."
- 4.9.2.3. **Production Testing.** The Contractor and Engineer must perform production tests in accordance with Table 11. The Contractor has the option to verify the Engineer's test results on split samples provided by the Engineer. Determine compliance with operational tolerances listed in Table 9 for all sublots.
- Take immediate corrective action if the Engineer's laboratory-molded density on any subplot is less than 95.0% or greater than 97.0% to bring the mixture within these tolerances. The Engineer may suspend operations if the Contractor's corrective actions do not produce acceptable results. The Engineer will allow production to resume when the proposed corrective action is likely to yield acceptable results.
- At any time during production the Engineer may require the Contractor to verify the following based on quantities used:
- lime content (within $\pm 0.1\%$ of JMF), when PG binder is specified;
 - fiber content (within $\pm 0.03\%$ of JMF), when PG binder is specified; and
 - CRM content (within $\pm 1.5\%$ of JMF), when A-R binder is specified.

Maintain the in-line measuring device to verify the A-R binder viscosity between 2,500 and 4,000 centipoise at 350°F when A-R binder is specified unless otherwise approved. Record A-R binder viscosity at least once an hour and provide the Engineer with a daily summary unless otherwise directed.

The Engineer may allow alternate methods for determining the asphalt binder content and aggregate gradation if the aggregate mineralogy is such that Tex-236-F does not yield reliable results. Provide evidence that results from Tex-236-F are not reliable before requesting permission to use an alternate method unless otherwise directed. Use the applicable test procedure as directed if an alternate test method is allowed.

Table 11
Production and Placement Testing Frequency

Description	Test Method	Minimum Contractor Testing Frequency	Minimum Engineer Testing Frequency
Individual % retained for #8 sieve and larger	Tex-200-F or Tex-236-F	1 per subplot	1 per 12 sublots ¹
Individual % retained for sieves smaller than #8 and larger than #200			
% passing the #200 sieve			
Laboratory-molded density	Tex-207-F	N/A	1 per subplot ¹
Laboratory-molded bulk specific gravity			
In-place air voids			
VMA	Tex-204-F		
Segregation (density profile) ²	Tex-207-F, Part V	1 per subplot	1 per project
Longitudinal joint density	Tex-207-F, Part VII		
Moisture content	Tex-212-F, Part II	When directed	
Theoretical maximum specific (Rice) gravity	Tex-227-F	N/A	1 per subplot ¹
Drain-down	Tex-235-F		1 per 12 ¹ sublots
Asphalt binder content	Tex-236-F	1 per subplot	1 p e r l o t 1
Hamburg Wheel test	Tex-242-F	N/A	1 per project
Recycled Asphalt Shingles (RAS) ³	Tex-217-F, Part III	N/A	
Thermal profile ²	Tex-244-F	1 per subplot	
Asphalt binder sampling and testing	Tex-500-C	1 per lot (sample only)	
Tack coat sampling and testing	Tex-500-C, Part III	N/A	
Boil test ⁴	Tex-530-C	1 per lot	
Cantabro Test ⁵	Tex-245-F	1 per project (sample only)	

- For production defined in Section 346.4.9.4., "Exempt Production," the Engineer will test one per day if 100 tons or more are produced. For Exempt Production, no testing is required when less than 100 tons are produced.
- Not required when a thermal imaging system is used.
- Testing performed by the Construction Division or designated laboratory.
- The Engineer may reduce or waive the sampling and testing requirements based on a satisfactory test history.
- Testing performed by the Construction Division and for informational purposes only.

4.9.2.4. **Operational Tolerances.** Control the production process within the operational tolerances listed in Table 9. When production is suspended, the Engineer will allow production to resume when test results or other information indicates the next mixture produced will be within the operational tolerances.

4.9.2.4.1. **Gradation.** Suspend operation and take corrective action if any aggregate is retained on the maximum sieve size shown in Table 7. A subplot is defined as out of tolerance if either the Engineer's or the Contractor's test results are out of operational tolerance. Suspend production when test results for gradation exceed the operational tolerances for 3 consecutive sublots on the same sieve or 4 consecutive sublots on any sieve unless otherwise directed. The consecutive sublots may be from more than one lot.

- 4.9.2.4.2. **Asphalt Binder Content.** A subplot is defined as out of operational tolerance if either the Engineer's or the Contractor's test results exceed the values listed in Table 9. No production or placement payment adjustments greater than 1.000 will be paid for any subplot that is out of operational tolerance for asphalt binder content. Suspend production and shipment of the mixture if the Engineer's or the Contractor's asphalt binder content deviates from the current JMF by more than 0.5% for any subplot.
- 4.9.2.4.3. **Voids in Mineral Aggregates (VMA).** The Engineer will determine the VMA for every subplot. For sublots when the Engineer does not determine asphalt binder content, the Engineer will use the asphalt binder content results from QC testing performed by the Contractor to determine VMA.
- Take immediate corrective action if the VMA value for any subplot is less than the minimum VMA requirement for production listed in Table 7. Suspend production and shipment of the mixture if the Engineer's VMA results on 2 consecutive sublots are below the minimum VMA requirement for production listed in Table 7. No production or placement payment adjustments greater than 1.000 will be paid for any subplot that does not meet the minimum VMA requirement for production listed in Table 7 based on the Engineer's VMA determination.
- Suspend production and shipment of the mixture if the Engineer's VMA result is more than 0.5% below the minimum VMA requirement for production listed in Table 7. In addition to suspending production, the Engineer may require removal and replacement or may allow the subplot to be left in place without payment.
- 4.9.2.4.4. **Fibers.** Suspend production and shipment of the mixture if fiber content varies from the design target value by more than 10% on 2 consecutive tests.
- 4.9.2.4.5. **Hamburg Wheel Test.** The Engineer may perform a Hamburg Wheel test at any time during production including when the boil test indicates a change in quality from the materials submitted for JMF1. In addition to testing production samples, the Engineer may obtain cores and perform Hamburg Wheel tests on any areas of the roadway where rutting is observed. Suspend production until further Hamburg Wheel tests meet the specified values when the production or core samples fail the Hamburg Wheel test criteria in Table 8. Core samples, if taken, will be obtained from the center of the finished mat or other areas excluding the vehicle wheel paths. The Engineer may require up to the entire subplot of any mixture failing the Hamburg Wheel test to be removed and replaced at the Contractor's expense.
- If the Department's or Department-approved laboratory's Hamburg Wheel test results in a "remove and replace" condition, the Contractor may request that the Department confirm the results by re-testing the failing material. The Construction Division will perform the Hamburg Wheel tests and determine the final disposition of the material in question based on the Department's test results.
- 4.9.2.5. **Individual Loads of Hot-Mix.** The Engineer can reject individual truckloads of hot-mix. When a load of hot-mix is rejected for reasons other than temperature, contamination, or excessive uncoated particles, the Contractor may request that the rejected load be tested. Make this request within 4 hr. of rejection. The Engineer will sample and test the mixture. If test results are within the operational tolerances shown in Table 9, payment will be made for the load. If test results are not within operational tolerances, no payment will be made for the load.
- 4.9.3. **Placement Acceptance.**
- 4.9.3.1. **Placement Lot.** A placement lot consists of 4 placement sublots. A placement subplot consists of the area placed during a production subplot.
- 4.9.3.1.1. **Lot 1 Placement.** Placement payment adjustments greater than 1.000 for Lot 1 will be in accordance with Section 346.6.2., "Placement Payment Adjustment Factors"; however, no placement adjustment less than 1.000 will be assessed for any subplot placed in Lot 1, when the in-place air voids are greater than or equal to 2.7% and less than or equal to 8.0%. Remove and replace any subplot with in-place air voids less than 2.7% or greater than 8.0%.

- 4.9.3.1.2. **Incomplete Placement Lots.** An incomplete placement lot consists of the area placed as described in Section 346.4.9.2.1.1., “Incomplete Production Lots,” excluding areas defined in Section 346.4.9.3.1.4., “Miscellaneous Areas.” Placement sampling is required if the random sample plan for production resulted in a sample being obtained from an incomplete production subplot.
- 4.9.3.1.3. **Shoulders, Ramps, Etc.** Shoulders, ramps, intersections, acceleration lanes, deceleration lanes, and turn lanes are subject to in-place air void determination and payment adjustments unless designated on the plans as not eligible for in-place air void determination. Intersections may be considered miscellaneous areas when determined by the Engineer.
- 4.9.3.1.4. **Miscellaneous Areas.** Miscellaneous areas include areas that typically involve significant handwork or discontinuous paving operations, such as driveways, mailbox turnouts, crossovers, gores, spot level-up areas, and other similar areas. Temporary detours are subject to in-place air void determination when shown on the plans. Miscellaneous areas also include level-ups and thin overlays when the layer thickness specified on the plans is less than the minimum untrimmed core height eligible for testing shown in Table 10. The specified layer thickness is based on the rate of 110 lb./sq. yd. for each inch of pavement unless another rate is shown on the plans. When “level up” is listed as part of the item bid description code, a payment adjustment factor of 1.000 will be assigned for all placement sublots as described in Article 346.6, “Payment.” Miscellaneous areas are not eligible for random placement sampling locations. Compact miscellaneous areas in accordance with Section 346.4.8., “Compaction.” Miscellaneous areas are not subject to in-place air void determination, thermal profiles testing, segregation (density profiles), or longitudinal joint density evaluations.
- 4.9.3.2. **Placement Sampling.** The Engineer will select random numbers for all placement sublots at the beginning of the project. The Engineer will provide the Contractor with the placement random numbers immediately after the subplot is completed. Mark the roadway location at the completion of each subplot and record the station number. Determine one random sample location for each placement subplot in accordance with Tex-225-F. Adjust the random sample location by no more than necessary to achieve a 2-ft. clearance if the location is within 2 ft. of a joint or pavement edge.

Shoulders, ramps, intersections, acceleration lanes, deceleration lanes, and turn lanes are always eligible for selection as a random sample location; however, if a random sample location falls on one of these areas and the area is designated on the plans as not subject to in-place air void determination, cores will not be taken for the subplot and a 1.000 pay factor will be assigned to that subplot.

Provide the equipment and means to obtain and trim roadway cores on-site. On-site is defined as in close proximity to where the cores are taken. Obtain the cores within one working day of the time the placement subplot is completed unless otherwise approved. Obtain two 6-in. diameter cores side-by-side from within 1 ft. of the random location provided for the placement subplot. Mark the cores for identification, measure and record the untrimmed core height, and provide the information to the Engineer. The Engineer will witness the coring operation and measurement of the core thickness. Visually inspect each core and verify that the current paving layer is bonded to the underlying layer. Take corrective action if an adequate bond does not exist between the current and underlying layer to ensure that an adequate bond will be achieved during subsequent placement operations.

Trim the cores immediately after obtaining the cores from the roadway in accordance with Tex-207-F if the core heights meet the minimum untrimmed value listed in Table 10. Trim the cores on-site in the presence of the Engineer. Use a permanent marker or paint pen to record the lot and subplot numbers on each core as well as the designation as Core A or B. The Engineer may require additional information to be marked on the core and may choose to sign or initial the core. The Engineer will take custody of the cores immediately after they are trimmed and will retain custody of the cores until the Department’s testing is completed. Before turning the trimmed cores over to the Engineer, the Contractor may wrap the trimmed cores or secure them in a manner that will reduce the risk of possible damage occurring during transport by the Engineer. After testing, the Engineer will return the cores to the Contractor.

The Engineer may have the cores transported back to the Department’s laboratory at the HMA plant via the Contractor’s haul truck or other designated vehicle. In such cases where the cores will be out of the

Engineer's possession during transport, the Engineer will use Department-provided security bags and the Roadway Core Custody protocol located at <http://www.txdot.gov/business/specifications.htm> to provide a secure means and process that protects the integrity of the cores during transport.

Decide whether to include the pair of cores in the air void determination for that subplot if the core height before trimming is less than the minimum untrimmed value shown in Table 10. Trim the cores as described above before delivering to the Engineer if electing to have the cores included in the air void determination. Deliver untrimmed cores to the Engineer and inform the Engineer of the decision to not have the cores included in air void determination if electing to not have the cores included in air void determination. The placement pay factor for the subplot will be 1.000 if cores will not be included in air void determination.

Instead of the Contractor trimming the cores on-site immediately after coring, the Engineer and the Contractor may mutually agree to have the trimming operations performed at an alternate location such as a field laboratory or other similar location. In such cases, the Engineer will take possession of the cores immediately after they are obtained from the roadway and will retain custody of the cores until testing is completed. Either the Department or Contractor representative may perform trimming of the cores. The Engineer will witness all trimming operations in cases where the Contractor representative performs the trimming operation.

Dry the core holes and tack the sides and bottom immediately after obtaining the cores. Fill the hole with the same type of mixture and properly compact the mixture. Repair core holes with other methods when approved.

4.9.3.3. **Placement Testing.** Perform placement tests in accordance with Table 11. After the Engineer returns the cores, the Contractor may test the cores to verify the Engineer's test results for in-place air voids. The allowable differences between the Contractor's and Engineer's test results are listed in Table 9.

4.9.3.3.1. **In-Place Air Voids.** The Engineer will measure in-place air voids in accordance with Tex-207-F and Tex-227-F. Before drying to a constant weight, cores may be pre-dried using a Corelok or similar vacuum device to remove excess moisture. The Engineer will average the values obtained for all sublots in the production lot to determine the theoretical maximum specific gravity. The Engineer will use the average air void content for in-place air voids.

The Engineer will use the vacuum method to seal the core if required by Tex-207-F. The Engineer will use the test results from the unsealed core to determine the placement payment adjustment factor if the sealed core yields a higher specific gravity than the unsealed core. After determining the in-place air void content, the Engineer will return the cores and provide test results to the Contractor.

4.9.3.3.2. **Segregation (Density Profile).** Test for segregation using density profiles in accordance with Tex-207-F, Part V. Density profiles are not required and are not applicable when using a thermal imaging system. Density profiles are not applicable in areas described in Section 346.4.9.3.1.4., "Miscellaneous Areas."

Perform a density profile every time the paver stops for more than 60 sec. on areas that are identified by either the Contractor or the Engineer as having thermal segregation and on any visibly segregated areas unless otherwise approved. Perform a minimum of one profile per subplot if the paver does not stop for more than 60 sec. and there are no visibly segregated areas or areas that are identified as having thermal segregation.

Provide the Engineer with the density profile of every subplot in the lot within one working day of the completion of each lot. Report the results of each density profile in accordance with Section 346.4.2., "Reporting and Responsibilities."

The density profile is considered failing if it exceeds the tolerances in Table 12. No production or placement payment adjustments greater than 1.000 will be paid for any subplot that contains a failing density profile. When a hand-held thermal camera is used instead of a thermal imaging system, the Engineer will measure the density profile at least once per project. The Engineer's density profile results will be used when available. The Engineer may require the Contractor to remove and replace the area in question if the area

fails the density profile and has surface irregularities as defined in Section 346.4.9.3.3.5., "Irregularities." The subplot in question may receive a production and placement payment adjustment greater than 1.000, if applicable, when the defective material is successfully removed and replaced.

Investigate density profile failures and take corrective actions during production and placement to eliminate the segregation. Suspend production if 2 consecutive density profiles fail unless otherwise approved. Resume production after the Engineer approves changes to production or placement methods.

Table 12
Segregation (Density Profile) Acceptance Criteria

Mixture Type	Maximum Allowable Density Range (Highest to Lowest)	Maximum Allowable Density Range (Average to Lowest)
SMA-C & SMAR-C	8.0 pcf	5.0 pcf
SMA-D, SMA-F & SMAR-F	6.0 pcf	3.0 pcf

4.9.3.3.3. Longitudinal Joint Density.

4.9.3.3.3.1. **Informational Tests.** Perform joint density evaluations while establishing the rolling pattern, and verify that the joint density is no more than 3.0 pcf below the density taken at or near the center of the mat. Adjust the rolling pattern, if needed, to achieve the desired joint density. Perform additional joint density evaluations at least once per subplot unless otherwise directed.

4.9.3.3.3.2. **Record Tests.** Perform a joint density evaluation for each subplot at each pavement edge that is or will become a longitudinal joint. Joint density evaluations are not applicable in areas described in Section 346.4.9.3.1.4., "Miscellaneous Areas." Determine the joint density in accordance with Tex-207-F, Part VII. Record the joint density information and submit results on Department forms to the Engineer. The evaluation is considered failing if the joint density is more than 3.0 pcf below the density taken at the core random sample location and the correlated joint density is less than 90.0%. The Engineer will make independent joint density verification at least once per project and may make independent joint density verifications at the random sample locations. The Engineer's joint density test results will be used when available.

Provide the Engineer with the joint density of every subplot in the lot within one working day of the completion of each lot. Report the results of each joint density in accordance with Section 346.4.2., "Reporting and Responsibilities."

Investigate joint density failures and take corrective actions during production and placement to improve the joint density. Suspend production if the evaluations on 2 consecutive sublots fail unless otherwise approved. Resume production after the Engineer approves changes to production or placement methods.

4.9.3.3.4. **Recovered Asphalt Dynamic Shear Rheometer (DSR).** The Engineer may take production samples or cores from suspect areas of the project to determine recovered asphalt properties. Asphalt binders with an aging ratio greater than 3.5 do not meet the requirements for recovered asphalt properties and may be deemed defective when tested and evaluated by the Construction Division. The aging ratio is the DSR value of the extracted binder divided by the DSR value of the original unaged binder. Obtain DSR values in accordance with AASHTO T 315 at the specified high temperature PG of the asphalt. The Engineer may require removal and replacement of the defective material at the Contractor's expense. The asphalt binder will be recovered for testing from production samples or cores in accordance with Tex-211-F.

4.9.3.3.5. **Irregularities.** Identify and correct irregularities including segregation, rutting, raveling, flushing, fat spots, mat slippage, irregular color, irregular texture, roller marks, tears, gouges, streaks, uncoated aggregate particles, or broken aggregate particles. The Engineer may also identify irregularities, and in such cases, the Engineer will promptly notify the Contractor. If the Engineer determines that the irregularity will adversely affect pavement performance, the Engineer may require the Contractor to remove and replace (at the Contractor's expense) areas of the pavement that contain irregularities and areas where the mixture does not bond to the existing pavement. If irregularities are detected, the Engineer may require the Contractor to

immediately suspend operations or may allow the Contractor to continue operations for no more than one day while the Contractor is taking appropriate corrective action.

- 4.9.4. **Exempt Production.** When the anticipated daily production is less than 1,000 tons, the total production for the project is less than 5,000 tons, or when mutually agreed between the Engineer and the Contractor, the Engineer may deem the mixture as exempt production. Production may also be exempt when shown on the plans.

For exempt production, the Contractor is relieved of all production and placement sampling and testing requirements and the production and placement pay factors are 1.000. All other specification requirements apply and the Engineer will perform acceptance tests for production and placement listed in Table 14 when 100 tons or more per day are produced.

For exempt production:

- produce, haul, place, and compact the mixture in compliance with the specification and as directed;
- control mixture production to yield a laboratory-molded density that is within $\pm 1.0\%$ of the target laboratory-molded density as tested by the Engineer;
- compact the mixture in accordance with Section 346.4.8., "Compaction," and
- when a thermal imaging system is not used, the Engineer may perform segregation (density profiles) and thermal profiles in accordance with the specification.

- 4.9.5. **Ride Quality.** Measure ride quality in accordance with Item 585, "Ride Quality for Pavement Surfaces," unless otherwise shown on the plans.

5. MEASUREMENT

Hot mix will be measured by the ton of composite hot-mix. The composite hot-mix is the asphalt, aggregate, and additives. Measure the weight on scales in accordance with Item 520, "Weighing and Measuring Equipment." Provide the Engineer with a daily summary of the asphalt mass flow meter readings for SMAR mixtures unless otherwise directed.

6. PAYMENT

The work performed and materials furnished in accordance with this Item and measured as provided under Article 346.5., "Measurement," will be paid for at the unit bid price for "Stone Matrix Asphalt" of the mixture type, SAC, and binder specified. These prices are full compensation for surface preparation, materials including tack coat, placement, equipment, labor, tools, and incidentals.

Payment adjustments will be applied as determined in this Item; however, a payment adjustment factor of 1.000 will be assigned for all placement sublots for "level ups" only when "level up" is listed as part of the item bid description code. A payment adjustment factor of 1.000 will be assigned to all production and placement sublots when "exempt" is listed as part of the item bid description code.

Payment for each subplot, including applicable payment adjustments greater than 1.000, will only be paid for sublots when the Contractor supplies the Engineer with the required documentation for production and placement QC/QA, thermal profiles, segregation density profiles, and longitudinal joint densities in accordance with Section 346.4.2., "Reporting and Responsibilities." When a thermal imaging system is used, documentation is not required for thermal profiles or segregation density profiles on individual sublots; however, the thermal imaging system automated reports described in Tex-244-F are required.

Trial batches will not be paid for unless they are included in pavement work approved by the Department.

Payment adjustment for ride quality will be determined in accordance with Item 585, "Ride Quality for Pavement Surfaces."

- 6.1. **Production Payment Adjustment Factors.** The production payment adjustment factor is based on the laboratory-molded density using the Engineer's test results. A payment adjustment factor will be determined from Table 13 for each subplot using the deviation from the target laboratory-molded density defined in Table 8. The production payment adjustment factor for completed lots will be the average of the payment adjustment factors for the 4 sublots sampled within that lot.

Table 13
Production Payment Adjustment Factors for Laboratory-Molded Density¹

Absolute Deviation from Target Laboratory-Molded Density	Production Payment Adjustment Factor (Target Laboratory-Molded Density)
0.0	1.100
0.1	1.100
0.2	1.100
0.3	1.086
0.4	1.075
0.5	1.063
0.6	1.050
0.7	1.038
0.8	1.025
0.9	1.013
1.0	1.000
1.1	0.900
1.2	0.800
1.3	0.700
> 1.3	Remove and replace

1. If the Engineer's laboratory-molded density on any subplot is less than 95.0% or greater than 97.0%, take immediate corrective action to bring the mixture within these tolerances. The Engineer may suspend operations if the Contractor's corrective actions do not produce acceptable results. The Engineer will allow production to resume when the proposed corrective action is likely to yield acceptable results.

- 6.1.1. **Payment for Incomplete Production Lots.** Production payment adjustments for incomplete lots, described under Section 346.4.9.2.1.1., "Incomplete Production Lots," will be calculated using the average production pay factors from all sublots sampled. A production pay factor of 1.000 will be assigned to any lot when the random sampling plan did not result in collection of any samples.
- 6.1.2. **Production Sublots Subject to Removal and Replacement.** If after referee testing, the laboratory-molded density for any subplot results in a "remove and replace" condition as listed in Table 13, the Engineer may require removal and replacement or may allow the subplot to be left in place without payment. The Engineer may also accept the subplot in accordance with Section 5.3.1., "Acceptance of Defective or Unauthorized Work." Replacement material meeting the requirements of this Item will be paid for in accordance with this Section.
- 6.2. **Placement Payment Adjustment Factors.** The placement payment adjustment factor is based on in-place air voids using the Engineer's test results. A payment adjustment factor will be determined from Table 14 for each subplot that requires in-place air void measurement. A placement payment adjustment factor of 1.000 will be assigned to the entire subplot when the random sample location falls in an area designated on the plans as not subject to in-place air void determination. A placement payment adjustment factor of 1.000 will be assigned to quantities placed in areas described in Section 346.4.9.3.1.4., "Miscellaneous Areas." The placement payment adjustment factor for completed lots will be the average of the placement payment adjustment factors for up to 4 sublots within that lot.

Table 14
Placement Payment Adjustment Factors for In-Place Air Voids

In-Place Air Voids	Placement Payment Adjustment Factor	In-Place Air Voids	Placement Payment Adjustment Factor
< 2.7	Remove and Replace	5.4	1.080
2.7	0.710	5.5	1.075
2.8	0.740	5.6	1.070
2.9	0.770	5.7	1.065
3.0	0.800	5.8	1.060
3.1	0.830	5.9	1.055
3.2	0.860	6.0	1.050
3.3	0.890	6.1	1.045
3.4	0.920	6.2	1.040
3.5	0.950	6.3	1.035
3.6	0.980	6.4	1.030
3.7	1.010	6.5	1.025
3.8	1.040	6.6	1.020
3.9	1.070	6.7	1.015
4.0	1.100	6.8	1.010
4.1	1.100	6.9	1.005
4.2	1.100	7.0	1.000
4.3	1.100	7.1	0.970
4.4	1.100	7.2	0.940
4.5	1.100	7.3	0.910
4.6	1.100	7.4	0.880
4.7	1.100	7.5	0.850
4.8	1.100	7.6	0.820
4.9	1.100	7.7	0.790
5.0	1.100	7.8	0.760
5.1	1.095	7.9	0.730
5.2	1.090	8.0	0.700
5.3	1.085	> 8.0	Remove and Replace

- 6.2.1. **Payment for Incomplete Placement Lots.** Payment adjustments for incomplete placement lots described under Section 346.4.9.3.1.2., "Incomplete Placement Lots," will be calculated using the average of the placement pay factors from all sublots sampled and sublots where the random location falls in an area designated on the plans as not eligible for in-place air void determination. A placement payment adjustment factor of 1.000 will be assigned to any lot when the random sampling plan did not result in collection of any samples.
- 6.2.2. **Placement Sublots Subject to Removal and Replacement.** If after referee testing, the placement payment adjustment factor for any subplot results in a "remove and replace" condition as listed in Table 14, the Engineer will choose the location of 2 cores to be taken within 3 ft. of the original failing core location. The Contractor will obtain the cores in the presence of the Engineer. The Engineer will take immediate possession of the untrimmed cores and submit the untrimmed cores to the Construction Division, where they will be trimmed if necessary and tested for bulk specific gravity within 10 working days of receipt. The average bulk specific gravity of the cores will be divided by the Engineer's average maximum theoretical specific gravity for that lot to determine the new payment adjustment factor of the subplot in question. If the new payment adjustment factor is 0.700 or greater, the new payment adjustment factor will apply to that subplot. If the new payment adjustment factor is less than 0.700, no payment will be made for the subplot. Remove and replace the failing subplot, or the Engineer may allow the subplot to be left in place without payment. The Engineer may also accept the subplot in accordance with Section 5.3.1., "Acceptance of Defective or Unauthorized Work." Replacement material meeting the requirements of this Item will be paid for in accordance with this Section.

- 6.3. **Total Adjusted Pay Calculation.** Total adjusted pay (TAP) will be based on the applicable payment adjustment factors for production and placement for each lot.

$$TAP = (A+B)/2$$

where:

A = Bid price × production lot quantity × average payment adjustment factor for the production lot

B = Bid price × placement lot quantity × average payment adjustment factor for the placement lot + (bid price × quantity placed in miscellaneous areas × 1.000)

Production lot quantity = Quantity actually placed - quantity left in place without payment

Placement lot quantity = Quantity actually placed - quantity left in place without payment - quantity placed in miscellaneous areas

Item 347

Thin Overlay Mixtures



1. DESCRIPTION

Construct a thin surface course composed of a compacted mixture of aggregate and asphalt binder mixed hot in a mixing plant. Produce a thin overlay mixture (TOM) with a minimum lift thickness of 1/2 in. for a Type F mixture and 3/4 in. for a Type C mixture.

2. MATERIALS

Furnish uncontaminated materials of uniform quality that meet the requirements of the plans and specifications.

Notify the Engineer of all material sources and before changing any material source or formulation. The Engineer will verify that the specification requirements are met when the Contractor makes a source or formulation change, and may require a new laboratory mixture design, trial batch, or both. The Engineer may sample and test project materials at any time during the project to verify specification compliance in accordance with Item 6, "Control of Materials."

2.1. **Aggregate.** Furnish aggregates from sources that conform to the requirements shown in Table 1 and as specified in this Section. Aggregate requirements in this Section, including those shown in Table 1, may be modified or eliminated when shown on the plans. Additional aggregate requirements may be specified when shown on the plans. Provide aggregate stockpiles that meet the definitions in this Section for coarse, intermediate, or fine aggregate. Do not use reclaimed asphalt pavement (RAP) or recycled asphalt shingles (RAS). Supply aggregates that meet the definitions in Tex-100-E for crushed gravel or crushed stone. The Engineer will designate the plant or the quarry as the sampling location. Provide samples from materials produced for the project. The Engineer will establish the Surface Aggregate Classification (SAC) and perform Los Angeles abrasion, magnesium sulfate soundness, and Micro-Deval tests. Perform all other aggregate quality tests listed in Table 1. Document all test results on the mixture design report. The Engineer may perform tests on independent or split samples to verify Contractor test results. Stockpile aggregates for each source and type separately. Determine aggregate gradations for mixture design and production testing based on the washed sieve analysis given in Tex-200-F, Part II.

2.1.1. **Coarse Aggregate.** Coarse aggregate stockpiles must have no more than 20% material passing the No. 8 sieve. Aggregates from sources listed in the Department's *Bituminous Rated Source Quality Catalog* (BRSQC) are preapproved for use. Use only the rated values for hot-mix listed in the BRSQC. Rated values for surface treatment (ST) do not apply to coarse aggregate sources used in hot-mix asphalt.

For sources not listed on the Department's BRSQC:

- build an individual stockpile for each material;
- request the Department test the stockpile for specification compliance; and
- once approved, do not add material to the stockpile unless otherwise approved.

Provide aggregate from non-listed sources only when tested by the Engineer and approved before use. Allow 30 calendar days for the Engineer to sample, test, and report results for non-listed sources.

2.1.1.1. **Blending Class A and Class B Aggregates.** Class B aggregate meeting all other requirements in Table 1 may be blended with a Class A aggregate to meet requirements for Class A materials; however, Class B aggregate may be disallowed when shown on the plans. Ensure that at least 50% by weight, or volume if required, of the material retained on the No. 8 sieve comes from the Class A aggregate source when

blending Class A and B aggregates to meet a Class A requirement. Blend by volume if the bulk specific gravities of the Class A and B aggregates differ by more than 0.300.

The Engineer may perform tests at any time during production, when the Contractor blends Class A and B aggregates to meet a Class A requirement, to ensure that at least 50% by weight, or volume if required, of the material retained on the No. 8 sieve comes from the Class A aggregate source. The Engineer will use the Department's mix design template, when electing to verify conformance, to calculate the percent of Class A aggregate retained on the No. 8 sieve by inputting the bin percentages shown from readouts in the control room at the time of production and stockpile gradations measured at the time of production. The Engineer may determine the gradations based on either washed or dry sieve analysis from samples obtained from individual aggregate cold feed bins or aggregate stockpiles. The Engineer may perform spot checks using the gradations supplied by the Contractor on the mixture design report as an input for the template; however, a failing spot check will require confirmation with a stockpile gradation determined by the Engineer.

- 2.1.1.2. **Micro-Deval Abrasion.** The Engineer will perform a minimum of one Micro-Deval abrasion test in accordance with Tex-461-A for each coarse aggregate source used in the mixture design that has a Rated Source Soundness Magnesium (RSSM) loss value greater than 15 as listed in the BRSCQ. The Engineer will perform testing before the start of production and may perform additional testing at any time during production. The Engineer may obtain the coarse aggregate samples from each coarse aggregate source or may require the Contractor to obtain the samples. The Engineer may waive all Micro-Deval testing based on a satisfactory test history of the same aggregate source.

The Engineer will estimate the magnesium sulfate soundness loss for each coarse aggregate source, when tested, using the following formula:

$$Mg_{est} = (RSSM)(MD_{act}/RSMD)$$

where:

Mg_{est} = magnesium sulfate soundness loss

MD_{act} = actual Micro-Deval percent loss

$RSMD$ = Rated Source Micro-Deval

When the estimated magnesium sulfate soundness loss is greater than the maximum magnesium sulfate soundness loss specified, the coarse aggregate source will not be allowed for use unless otherwise approved. The Engineer will consult the Geotechnical, Soils, and Aggregates Branch of the Construction Division, and additional testing may be required before granting approval.

- 2.1.2. **Intermediate Aggregate.** Aggregates not meeting the definition of coarse or fine aggregate will be defined as intermediate aggregate. Supply intermediate aggregates, when used that are free from organic impurities. The Engineer may test the intermediate aggregate in accordance with Tex-408-A to verify the material is free from organic impurities. Supply intermediate aggregate from coarse aggregate sources, when used that meet the requirements shown in Table 1 unless otherwise approved.

Test the stockpile if 10% or more of the stockpile is retained on the No. 4 sieve and verify that it meets the requirements in Table 1 for crushed face count (Tex-460-A) and flat and elongated particles (Tex-280-F).

- 2.1.3. **Fine Aggregate.** Fine aggregates consist of manufactured sands and screenings. Natural sands are not allowed in any mixture. Fine aggregate stockpiles must meet the gradation requirements in Table 2. Supply fine aggregates that are free from organic impurities. The Engineer may test the fine aggregate in accordance with Tex-408-A to verify the material is free from organic impurities. Use fine aggregate from coarse aggregate sources that meet the requirements shown in Table 1 unless otherwise approved.

Test the stockpile if 10% or more of the stockpile is retained on the No. 4 sieve and verify that it meets the requirements shown in Table 1 for crushed face count (Tex-460-A) and flat and elongated particles (Tex-280-F).

Table 1
Aggregate Quality Requirements

Property	Test Method	Requirement
Coarse Aggregate		
SAC	Tex-499-A (AQMP)	A ¹
Deleterious material, %, Max	Tex-217-F, Part I	1.5
Decantation, %, Max	Tex-217-F, Part II	1.5
Micro-Deval abrasion, %	Tex-461-A	Note ²
Los Angeles abrasion, %, Max	Tex-410-A	30
Magnesium sulfate soundness, 5 cycles, %, Max	Tex-411-A	20
Crushed face count, ³ %, Min	Tex-460-A, Part I	95
Flat and elongated particles @ 5:1, %, Max	Tex-280-F	10
Fine Aggregate		
Linear shrinkage, %, Max	Tex-107-E	3
Combined Aggregate⁴		
Sand equivalent, %, Min	Tex-203-F	45

1. Surface Aggregate Classification of "A" is required unless otherwise shown on the plans.
2. Used to estimate the magnesium sulfate soundness loss in accordance with Section 347.2.1.1.2., "Micro-Deval Abrasion."
3. Only applies to crushed gravel.
4. Aggregates, without mineral filler or additives, combined as used in the job-mix formula (JMF).

Table 2
Gradation Requirements for Fine Aggregate

Sieve Size	% Passing by Weight or Volume
3/8"	100
#8	70–100
#200	0–30

- 2.2. **Mineral Filler.** Mineral filler consists of finely divided mineral matter such as agricultural lime, crusher fines, hydrated lime, or fly ash. Mineral filler is allowed unless otherwise shown on the plans. Use no more than 2% hydrated lime unless otherwise shown on the plans. Test all mineral fillers except hydrated lime and fly ash in accordance with Tex-107-E to ensure specification compliance. The plans may require or disallow specific mineral fillers. Provide mineral filler, when used, that:
- is sufficiently dry, free-flowing, and free from clumps and foreign matter as determined by the Engineer;
 - does not exceed 3% linear shrinkage when tested in accordance with Tex-107-E; and
 - meets the gradation requirements in Table 3.

Table 3
Gradation Requirements for Mineral Filler

Sieve Size	% Passing by Weight or Volume
#8	100
#200	55–100

- 2.3. **Baghouse Fines.** Fines collected by the baghouse or other dust-collecting equipment may be reintroduced into the mixing drum.
- 2.4. **Asphalt Binder.** Furnish performance-graded (PG) asphalt binder with a high temperature grade of PG 76 or 70 and a low temperature grade as shown on the plans, in accordance with Section 300.2.10., "Performance-Graded Binders."
- 2.5. **Tack Coat.** Furnish CSS-1H, SS-1H, or a PG binder with a minimum high-temperature grade of PG 58 for tack coat binder in accordance with Item 300, "Asphalts, Oils, and Emulsions." Specialized or preferred tack coat materials may be allowed or required when shown on the plans. Do not dilute emulsified asphalts at the terminal, in the field, or at any other location before use.

The Engineer will obtain at least one sample of the tack coat binder per project in accordance with Tex-500-C, Part III, and test it to verify compliance with Item 300, "Asphalts, Oils, and Emulsions." The Engineer will obtain the sample from the asphalt distributor immediately before use.

- 2.6. **Additives.** Use the type and rate of additive specified when shown on the plans. Additives that facilitate mixing, compaction, or improve the quality of the mixture are allowed when approved. Provide the Engineer with documentation such as the bill of lading showing the quantity of additives used in the project unless otherwise directed.
- 2.6.1. **Lime and Liquid Antistripping Agent.** When lime or a liquid antistripping agent is used, add in accordance with Item 301, "Asphalt Antistripping Agents." Use no more than 1% hydrated lime when using crushed gravel. Do not add lime directly into the mixing drum of any plant where lime is removed through the exhaust stream unless the plant has a baghouse or dust collection system that reintroduces the lime into the drum.
- 2.6.2. **Warm Mix Asphalt (WMA).** Warm Mix Asphalt (WMA) is defined as HMA that is produced within a target temperature discharge range of 215°F and 275°F using approved WMA additives or processes from the Department's MPL.
- WMA is allowed for use on all projects and is required when shown on the plans. When WMA is required, the maximum placement or target discharge temperature for WMA will be set at a value below 275°F. Department-approved WMA additives may be used to facilitate mixing and compaction of HMA produced at target discharge temperatures greater than 275°F; however, such mixtures will not be defined as WMA.
- 2.7. **Recycled Materials.** Recycled materials are not allowed for use.

3. EQUIPMENT

Provide required or necessary equipment in accordance with Item 320, "Equipment for Asphalt Concrete Pavement."

4. CONSTRUCTION

Produce, haul, place, and compact the specified paving mixture. In addition to tests required by the specification, Contractors may perform other QC tests as deemed necessary. At any time during the project, the Engineer may perform production and placement tests as deemed necessary in accordance with Item 5, "Control of the Work." Schedule and participate in a mandatory pre-paving meeting with the Engineer on or before the first day of paving unless otherwise shown on the plans.

- 4.1. **Certification.** Personnel certified by the Department-approved hot-mix asphalt certification program must conduct all mixture designs, sampling, and testing in accordance with Table 4. Supply the Engineer with a list of certified personnel and copies of their current certificates before beginning production and when personnel changes are made. Provide a mixture design developed and signed by a Level 2 certified specialist. Provide Level 1A certified specialists at the plant during production operations. Provide Level 1B certified specialists to conduct placement tests.

**Table 4
Test Methods, Test Responsibility, and Minimum Certification Levels**

Test Description	Test Method	Contractor	Engineer	Level ¹
1. Aggregate Testing				
Sampling	Tex-221-F	✓	✓	1A
Dry sieve	Tex-200-F, Part I	✓	✓	1A
Washed sieve	Tex-200-F, Part II	✓	✓	1A
Deleterious material	Tex-217-F, Part I	✓	✓	1A
Decantation	Tex-217-F, Part II	✓	✓	1A
Los Angeles abrasion	Tex-410-A		✓	TxDOT
Magnesium sulfate soundness	Tex-411-A		✓	TxDOT
Micro-Deval abrasion	Tex-461-A		✓	2
Crushed face count	Tex-460-A	✓	✓	2
Flat and elongated particles	Tex-280-F	✓	✓	2
Linear shrinkage	Tex-107-E	✓	✓	2
Sand equivalent	Tex-203-F	✓	✓	2
Organic impurities	Tex-408-A	✓	✓	2
2. Asphalt Binder & Tack Coat Sampling				
Asphalt binder sampling	Tex-500-C, Part II	✓	✓	1A/1B
Tack coat sampling	Tex-500-C, Part III	✓	✓	1A/1B
3. Mix Design & Verification				
Design and JMF changes	Tex-204-F	✓	✓	2
Mixing	Tex-205-F	✓	✓	2
Molding (TGC)	Tex-206-F	✓	✓	1A
Molding (SGC)	Tex-241-F	✓	✓	1A
Laboratory-molded density	Tex-207-F	✓	✓	1A
VMA ² (calculation only)	Tex-204-F	✓	✓	2
Rice gravity	Tex-227-F	✓	✓	1A
Drain-down	Tex-235-F	✓	✓	1A
Ignition oven correction factors ³	Tex-236-F	✓	✓	2
Indirect tensile strength	Tex-226-F	✓	✓	2
Overlay test	Tex-248-F		✓	TxDOT
Hamburg Wheel test	Tex-242-F	✓	✓	2
Boil test	Tex-530-C	✓	✓	1A
4. Production Testing				
Selecting production random numbers	Tex-225-F, Part I		✓	1A
Mixture sampling	Tex-222-F	✓	✓	1A
Molding (TGC)	Tex-206-F	✓	✓	1A
Molding (SGC)	Tex-241-F	✓	✓	1A
Laboratory-molded density	Tex-207-F	✓	✓	1A
VMA ² (calculation only)	Tex-204-F	✓	✓	1A
Rice gravity	Tex-227-F	✓	✓	1A
Gradation & asphalt binder content ³	Tex-236-F	✓	✓	1A
Drain-down	Tex-235-F	✓	✓	1A
Control charts	Tex-233-F	✓	✓	1A
Moisture content	Tex-212-F	✓	✓	1A
Hamburg Wheel test	Tex-242-F	✓	✓	2
Overlay test	Tex-248-F	✓	✓	TxDOT
Micro-Deval abrasion	Tex-461-A		✓	2
Boil test	Tex-530-C	✓	✓	1A
Abson recovery	Tex-211-F		✓	TxDOT
5. Placement Testing				
Establish rolling pattern	Tex-207-F	✓		1B
Control charts	Tex-233-F	✓	✓	1A
Ride quality measurement	Tex-1001-S	✓	✓	Note ⁴
Thermal profile	Tex-244-F	✓	✓	1B
Water flow	Tex-246-F	✓	✓	1B

- Level 1A, 1B, and 2 are certification levels provided by the Hot Mix Asphalt Center certification program.
- Void in mineral aggregates.
- Refer to Section 347.4.9.2.3., "Production Testing" for exceptions to using an ignition oven.
- Profiler and operator are required to be certified at the Texas A&M Transportation Institute facility when Surface Test Type B is specified.

4.2.

Reporting and Responsibilities. Use Department-provided templates to record and calculate all test data, including mixture design, production and placement QC/QA, control charts, and thermal profiles. Obtain the current version of the templates at <http://www.txdot.gov/inside-txdot/forms-publications/consultants-contractors/forms/site-manager.html> or from the Engineer. The Engineer and the Contractor will provide any available test results to the other party when requested. The maximum allowable time for the Contractor and Engineer to exchange test data is as given in Table 5 unless otherwise approved. The Engineer and the Contractor will immediately report to the other party any test result that requires suspension of production or placement or that fails to meet the specification requirements. Record and electronically submit all test results and pertinent information on Department-provided templates.

Subsequent sublots placed after test results are available to the Contractor, which require suspension of operations, may be considered unauthorized work. Unauthorized work will be accepted or rejected at the discretion of the Engineer in accordance with Article 5.3., "Conformity with Plans, Specifications, and Special Provisions."

Table 5
Reporting Schedule

Description	Reported By	Reported To	To Be Reported Within
<i>Production Quality Control</i>			
Gradation ¹	Contractor	Engineer	1 working day of completion of the subplot
Asphalt binder content ¹			
Laboratory-molded density ²			
Moisture content ³			
Boil test ³			
<i>Production Quality Assurance</i>			
Gradation ³	Engineer	Contractor	1 working day of completion of the subplot
Asphalt binder content ³			
Laboratory-molded density ¹			
Hamburg Wheel test ²			
Overlay test ²			
Boil test ²			
Binder tests ²			
<i>Placement Quality Control</i>			
Thermal profile ¹	Contractor	Engineer	1 working day of completion of the lot
Water flow ¹			
<i>Placement Quality Assurance</i>			
Thermal profile ²	Engineer	Contractor	1 working day of completion of the lot
Aging ratio ²			
Water flow			

1. These tests are required on every subplot.
2. Optional test. To be reported as soon as results become available.
3. To be performed at the frequency specified on the plans.

Use the procedures described in Tex-233-F to plot the results of all quality control (QC) and quality assurance (QA) testing. Update the control charts as soon as test results for each subplot become available. Make the control charts readily accessible at the field laboratory. The Engineer may suspend production for failure to update control charts.

4.3.

Quality Control Plan (QCP). Develop and follow the QCP in detail. Obtain approval for changes to the QCP made during the project. The Engineer may suspend operations if the Contractor fails to comply with the QCP.

Submit a written QCP before the mandatory pre-paving meeting. Receive approval of the QCP before beginning production. Include the following items in the QCP:

4.3.1.

Project Personnel. For project personnel, include:

- a list of individuals responsible for QC with authority to take corrective action;
- current contact information for each individual listed; and
- current copies of certification documents for individuals performing specified QC functions.

- 4.3.2. **Material Delivery and Storage.** For material delivery and storage, include:
- the sequence of material processing, delivery, and minimum quantities to assure continuous plant operations;
 - aggregate stockpiling procedures to avoid contamination and segregation;
 - frequency, type, and timing of aggregate stockpile testing to assure conformance of material requirements before mixture production; and
 - procedure for monitoring the quality and variability of asphalt binder.
- 4.3.3. **Production.** For production, include:
- loader operation procedures to avoid contamination in cold bins;
 - procedures for calibrating and controlling cold feeds;
 - procedures to eliminate debris or oversized material;
 - procedures for adding and verifying rates of each applicable mixture component (e.g., aggregate, asphalt binder, lime, liquid antistrip, WMA);
 - procedures for reporting job control test results; and
 - procedures to avoid segregation and drain-down in the silo.
- 4.3.4. **Loading and Transporting.** For loading and transporting, include:
- type and application method for release agents; and
 - truck loading procedures to avoid segregation.
- 4.3.5. **Placement and Compaction.** For placement and compaction, include:
- proposed agenda for mandatory pre-paving meeting, including date and location;
 - proposed paving plan (e.g., paving widths, joint offsets, and lift thicknesses);
 - type and application method for release agents in the paver and on rollers, shovels, lutes, and other utensils;
 - procedures for the transfer of mixture into the paver, while avoiding segregation and preventing material spillage;
 - process to balance production, delivery, paving, and compaction to achieve continuous placement operations and good ride quality;
 - paver operations (e.g., operation of wings, height of mixture in auger chamber) to avoid physical and thermal segregation and other surface irregularities; and
 - procedures to construct quality longitudinal and transverse joints.
- 4.4. **Mixture Design.**
- 4.4.1. **Design Requirements.** The Contractor may design the mixture using a Texas Gyratory Compactor (TGC) or a Superpave Gyratory Compactor (SGC) unless otherwise shown on the plans. Use the typical weight design example given in Tex-204-F, Part I, when using a TGC. Use the Superpave mixture design procedure provided in Tex-204-F, Part IV, when using a SGC. Design the mixture to meet the requirements listed in Tables 1, 2, 3, 6, and 7.
- 4.4.1.1. **Target Laboratory-Molded Density When The TGC Is Used.** Design the mixture at a 97.5% target laboratory-molded density or as noted in Table 7.
- 4.4.1.2. **Design Number of Gyration (Ndesign) When The SGC Is Used.** Design the mixture at 50 gyrations (Ndesign). Use a target laboratory-molded density of 96.0% to design the mixture; however, adjustments can be made to the Ndesign value as noted in Table 7. The Ndesign level may be reduced to no less than 35 gyrations at the Contractor's discretion.

Use an approved laboratory from the Department's MPL to perform the Hamburg Wheel test, and the Department will perform the Overlay test and provide results with the mixture design, or provide the

laboratory mixture and request that the Department perform the Hamburg Wheel test and Overlay test. The Engineer will be allowed 10 working days to provide the Contractor with Hamburg Wheel test and Overlay test results on the laboratory mixture design.

The Engineer will provide the mixture design when shown on the plans. The Contractor may submit a new mixture design at any time during the project. The Engineer will verify and approve all mixture designs (JMF1) before the Contractor can begin production.

Provide the Engineer with a mixture design report using the Department-provided template. Include the following items in the report:

- the combined aggregate gradation, source, specific gravity, and percent of each material used;
- the target laboratory-molded density (or Ndesign level when using the SGC);
- results of all applicable tests;
- the mixing and molding temperatures;
- the signature of the Level 2 person or persons that performed the design;
- the date the mixture design was performed; and
- a unique identification number for the mixture design.

Table 6
Master Gradation Limits (% Passing by Weight or Volume) and Volumetric Requirements

Sieve Size	Coarse (TOM-C)	Fine (TOM-F)
1/2"	100.0 ¹	100.0 ¹
3/8"	95.0–100.0	98.0–100.0
#4	40.0–60.0	70.0–95.0
#8	17.0–27.0	40.0–65.0
#16	5.0–27.0	20.0–45.0
#30	5.0–27.0	10.0–35.0
#50	5.0–27.0	10.0–20.0
#200	5.0–9.0	2.0–12.0
Asphalt Binder Content,² % Min		
-	6.0	6.5
Design VMA,³ % Min		
-	16.0	16.5
Production (Plant-Produced) VMA,³ % Min		
-	15.5	16.0

1. Defined as maximum sieve size. No tolerance allowed.
2. Unless otherwise shown on the plans or approved by the Engineer.
3. Voids in Mineral Aggregates (VMA).

Table 7
Laboratory Mixture Design Properties

Mixture Property	Test Method	Requirement
Target laboratory-molded density, % (TGC)	Tex-207 F	97.5 ¹
Design gyrations (Ndesign for SGC)	Tex-241-F	50 ²
Hamburg Wheel test, passes at 12.5 mm rut depth for PG 70 mixtures	Tex-242-F	15,000 Min
Hamburg Wheel test, passes at 12.5 mm rut depth for PG 76 mixtures	Tex-242-F	20,000 Min
Tensile strength (dry), psi.	Tex-226-F	85–200
Overlay test, number of cycles	Tex-248-F	300 Min
Drain-down, %	Tex-235-F	0.20 Max

1. Unless otherwise shown on the plans or approved by the Engineer.
2. May be adjusted within the range of 35–100 gyrations when shown on the plans or specification or when mutually agreed between the Engineer and Contractor.

4.4.2.

Job-Mix Formula Approval. The job-mix formula (JMF) is the combined aggregate gradation, target laboratory-molded density (or Ndesign level), and target asphalt percentage used to establish target values for hot-mix production. JMF1 is the original laboratory mixture design used to produce the trial batch. When WMA is used, JMF1 may be designed and submitted to the Engineer without including the WMA additive. When WMA is used, document the additive or process used and recommended rate on the JMF1 submittal. The Engineer and the Contractor will verify JMF1 based on plant-produced mixture from the trial batch

unless otherwise approved. The Engineer may accept an existing mixture design previously used on a Department project and may waive the trial batch to verify JMF1. The Department may require the Contractor to reimburse the Department for verification tests if more than 2 trial batches per design are required.

4.4.2.1. **Contractor's Responsibilities.**

4.4.2.1.1. **Providing Gyratory Compactor.** Use a TGC calibrated in accordance with Tex-914-K when electing or required to design the mixture in accordance with Tex-204-F, Part I, for molding production samples. Furnish an SGC calibrated in accordance with Tex-241-F when electing or required to design the mixture in accordance with Tex-204-F, Part IV, for molding production samples. Locate the SGC if used, at the Engineer's field laboratory and make the SGC available to the Engineer for use in molding production samples.

4.4.2.1.2. **Gyratory Compactor Correlation Factors.** Use Tex-206-F, Part II, to perform a gyratory compactor correlation when the Engineer uses a different gyratory compactor. Apply the correlation factor to all subsequent production test results.

4.4.2.1.3. **Submitting JMF1.** Furnish a mix design report (JMF1) with representative samples of all component materials and request approval to produce the trial batch. Provide approximately 25 lb. of the design mixture if opting to have the Department perform the Hamburg Wheel test on the laboratory mixture, and request that the Department perform the test. Provide approximately 50 lb. of the design mixture to perform the Overlay test.

4.4.2.1.4. **Supplying Aggregates.** Provide approximately 40 lb. of each aggregate stockpile unless otherwise directed.

4.4.2.1.5. **Supplying Asphalt.** Provide at least 1 gal. of the asphalt material and sufficient quantities of any additives proposed for use.

4.4.2.1.6. **Ignition Oven Correction Factors.** Determine the aggregate and asphalt correction factors from the ignition oven in accordance with Tex-236-F. Provide the Engineer with split samples of the mixtures before the trial batch production, including all additives (except water), and blank samples used to determine the correction factors for the ignition oven used for QA testing during production. Correction factors established from a previously approved mixture design may be used for the current mixture design if the mixture design and ignition oven are the same as previously used unless otherwise directed.

4.4.2.1.7. **Boil Test.** Perform the test and retain the tested sample from Tex-530-C until completion of the project or as directed. Use this sample for comparison purposes during production. The Engineer may waive the requirement for the boil test.

4.4.2.1.8. **Trial Batch Production.** Provide a plant-produced trial batch upon receiving conditional approval of JMF1 and authorization to produce a trial batch, including the WMA additive or process, if applicable, for verification testing of JMF1 and development of JMF2. Produce a trial batch mixture that meets the requirements in Table 8. The Engineer may accept test results from recent production of the same mixture instead of a new trial batch.

Obtain and provide approximately 50 lb. of trial batch mixture in a sealed container, box, or bags labeled with the CSJ number, mixture type, and date for the Overlay test.

4.4.2.1.9. **Trial Batch Production Equipment.** Use only equipment and materials proposed for use on the project to produce the trial batch.

4.4.2.1.10. **Trial Batch Quantity.** Produce enough quantity of the trial batch to ensure that the mixture meets the specification requirements.

4.4.2.1.11. **Number of Trial Batches.** Produce trial batches as necessary to obtain a mixture that meets the specification requirements.

- 4.4.2.1.12. **Trial Batch Sampling.** Obtain a representative sample of the trial batch and split it into 3 equal portions in accordance with Tex-222-F. Label these portions as “Contractor,” “Engineer,” and “Referee.” Deliver samples to the appropriate laboratory as directed.
- 4.4.2.1.13. **Trial Batch Testing.** Test the trial batch to ensure the mixture produced using the proposed JMF1 meets the mixture requirements in Table 8. Ensure the trial batch mixture is also in compliance with the Hamburg Wheel test, Overlay test, and drain-down requirements listed in Table 7. Use a Department-approved laboratory to perform the Hamburg Wheel test on the trial batch mixture or request that the Department perform the Hamburg Wheel test. Obtain and provide approximately 50 lb. of trial batch mixture in sealed containers, boxes, or bags labeled with the CSJ, mixture type, lot, and subplot number for the Overlay test. The Engineer will be allowed 10 working days to provide the Contractor with Hamburg Wheel test and Overlay test results on the trial batch. Provide the Engineer with a copy of the trial batch test results.
- 4.4.2.1.14. **Development of JMF2.** Evaluate the trial batch test results after the Engineer grants full approval of JMF1 based on results from the trial batch, determine the optimum mixture proportions, and submit as JMF2. Adjust the asphalt binder content or gradation to achieve the specified target laboratory-molded density. The asphalt binder content established for JMF2 is not required to be within any tolerance of the optimum asphalt binder content established for JMF1; however, mixture produced using JMF2 must meet the voids in mineral aggregates (VMA) requirements for production shown in Table 6. If the optimum asphalt binder content for JMF2 is more than 0.5% lower than the optimum asphalt binder content for JMF1, the Engineer may perform or require the Contractor to perform Tex-226-F on Lot 1 production to confirm the indirect tensile strength does not exceed 200 psi and the Overlay test exceeds 300 cycles.
- 4.4.2.1.15. **Mixture Production.** Use JMF2 to produce Lot 1 after receiving approval for JMF2 and a passing result from the Department’s or a Department-approved laboratory’s Hamburg Wheel test and the Department’s Overlay test on the trial batch. If desired, proceed to Lot 1 production, once JMF2 is approved, at the Contractor’s risk without receiving the results from either the Department’s Hamburg Wheel test or Overlay test on the trial batch.
- Notify the Engineer if electing to proceed without Hamburg Wheel test and Overlay test results from the trial batch. Note that the Engineer may require up to the entire subplot of any mixture failing the Hamburg Wheel test or Overlay test to be removed and replaced at the Contractor’s expense.
- 4.4.2.1.16. **Development of JMF3.** Evaluate the test results from Lot 1, determine the optimum mixture proportions, and submit as JMF3 for use in Lot 2.
- 4.4.2.1.17. **JMF Adjustments.** If JMF adjustments are necessary to achieve the specified requirements, make the adjustments before beginning a new lot. The adjusted JMF must:
- be provided to the Engineer in writing before the start of a new lot;
 - be numbered in sequence to the previous JMF;
 - meet the master gradation limits shown in Table 6; and
 - be within the operational tolerances of JMF2 listed in Table 8.
- 4.4.2.1.18. **Requesting Referee Testing.** Use referee testing, if needed, in accordance with Section 347.4.9.1., “Referee Testing,” to resolve testing differences with the Engineer.

Table 8
Operational Tolerances

Description	Test Method	Allowable Difference between Trial Batch and JMF1 Target	Allowable Difference from Current JMF Target	Allowable Difference between Contractor and Engineer ¹
Individual % retained for #8 sieve and larger	Tex-200-F or Tex-236-F	Must be Within Master Grading Limits in Table 6	±3.0 ^{2,3}	±5.0
Individual % retained for sieves smaller than #8 and larger than #200			±3.0 ^{2,3}	±3.0
% passing the #200 sieve			±2.0 ^{2,3}	±1.6
Asphalt binder content, % ⁴	Tex-236-F	±0.3	±0.3 ³	±0.3
Laboratory-molded density, %	Tex-207-F	±1.0	±1.0	±1.0
Laboratory-molded bulk specific gravity		N/A	N/A	±0.020
VMA, % min	Tex-204-F	Note ⁴	Note ⁴	N/A
Theoretical maximum specific (Rice) gravity	Tex-227-F	N/A	N/A	±0.020
Drain-down, %	Tex-235-F	Note ⁵	Note ⁵	N/A

- Contractor may request referee testing only when values exceed these tolerances.
- When within these tolerances, mixture production gradations may fall outside the master grading limits; however, the % passing the #200 will be considered out of tolerance when outside the master grading limits.
- Only applies to mixture produced for Lot 1 and higher.
- Binder content is not allowed to be outside the limits shown in Table 6. May be obtained from asphalt meter readouts.
- Test and verify that Table 7 requirements are met.

4.4.2.2. **Engineer's Responsibilities.**

- 4.4.2.2.1. **Gyratory Compactor.** For mixtures designed in accordance with Tex-204-F, Part I, the Engineer will use a Department TGC, calibrated in accordance with Tex-914-K, to mold samples for trial batch and production testing. The Engineer will make the Department TGC and the Department field laboratory available to the Contractor for molding verification samples, if requested by the Contractor.

For mixtures designed in accordance with Tex-204-F, Part IV, the Engineer will use a Department SGC, calibrated in accordance with Tex-241-F, to mold samples for laboratory mixture design verification. For molding trial batch and production specimens, the Engineer will use the Contractor-provided SGC at the field laboratory or provide and use a Department SGC at an alternate location. The Engineer will make the Contractor-provided SGC in the Department field laboratory available to the Contractor for molding verification samples.

- 4.4.2.2.2. **Conditional Approval of JMF1 and Authorizing Trial Batch.** The Engineer will review and verify conformance of the following information within 2 working days of receipt:

- the Contractor's mix design report (JMF1);
- the Department-provided Overlay test results;
- the Contractor-provided Hamburg Wheel test results;
- all required materials including aggregates, asphalt, and additives; and
- the mixture specifications.

The Engineer will grant the Contractor conditional approval of JMF1 if the information provided on the paper copy of JMF1 indicates that the Contractor's mixture design meets the specifications. When the Contractor does not provide Hamburg Wheel test and Overlay test results with laboratory mixture design, 10 working days are allowed for conditional approval of JMF1. The Engineer will base full approval of JMF1 on test results on mixture from the trial batch.

Unless waived, the Engineer will determine the Micro-Deval abrasion loss in accordance with Section 347.2.1.1.2., "Micro-Deval Abrasion." If the Engineer's test results are pending after 2 working days, conditional approval of JMF1 will still be granted within 2 working days of receiving JMF1. When the Engineer's test results become available, they will be used for specification compliance.

After conditionally approving JMF1, including either Contractor- or Department-supplied Hamburg Wheel test results, the Contractor is authorized to produce a trial batch.

- 4.4.2.2.3. **Hamburg Wheel and Overlay Testing of JMF1.** If the Contractor requests the option to have the Department perform the Hamburg Wheel test on the laboratory mixture, the Engineer will mold samples in accordance with Tex-242-F to verify compliance with the Hamburg Wheel test requirement in Table 7. The Engineer will perform the Overlay test and mold samples in accordance with Tex-248-F to verify compliance with the Overlay test requirements in Table 7.
- 4.4.2.2.4. **Ignition Oven Correction Factors.** The Engineer will use the split samples provided by the Contractor to determine the aggregate and asphalt correction factors for the ignition oven used for QA testing during production in accordance with Tex-236-F.
- 4.4.2.2.5. **Testing the Trial Batch.** Within 1 full working day, the Engineer will sample and test the trial batch to ensure that the mixture meets the requirements in Table 8. The Engineer will mold samples in accordance with Tex-242-F if the Contractor requests the option to have the Department perform the Hamburg Wheel test on the trial batch mixture to verify compliance with Hamburg Wheel test requirements in Table 7. The Engineer will mold samples for the Overlay test in accordance with Tex-248-F to verify compliance with the Overlay test requirement in Table 7.
- The Engineer will have the option to perform the following tests on the trial batch:
- Tex-226-F, to verify that the indirect tensile strength meets the requirement shown in Table 8; and
 - Tex-530-C, to retain and use for comparison purposes during production.
- 4.4.2.2.6. **Full Approval of JMF1.** The Engineer will grant full approval of JMF1 and authorize the Contractor to proceed with developing JMF2 if the Engineer's results for the trial batch meet the requirements in Table 7. The Engineer will notify the Contractor that an additional trial batch is required if the trial batch does not meet these requirements.
- 4.4.2.2.7. **Approval of JMF2.** The Engineer will approve JMF2 within one working day if the gradation meets the master grading limits shown in Table 6 and is within the operational tolerances of JMF1 listed in Table 8. The asphalt binder content established for JMF2 is not required to be within any tolerance of the optimum asphalt binder content established for JMF1; however, mixture produced using JMF2 must meet the VMA requirements shown in Table 6. The Engineer may perform or require the Contractor to perform Tex-226-F on Lot 1 production to confirm the indirect tensile strength does not exceed 200 psi if the optimum asphalt binder content for JMF2 is more than 0.5% lower than the optimum asphalt binder content for JMF1.
- 4.4.2.2.8. **Approval of Lot 1 Production.** The Engineer will authorize the Contractor to proceed with Lot 1 production (using JMF2) as soon as a passing result is achieved from the Department's or a Department-approved laboratory's Hamburg Wheel test and from the Department's Overlay test. The Contractor may proceed at its own risk with Lot 1 production without the results from the Hamburg Wheel test and Overlay test on the trial batch.
- If the Department's or Department-approved laboratory's sample from the trial batch fails the Hamburg Wheel test or Overlay test, the Engineer will suspend production until further Hamburg Wheel tests or Overlay tests meet the specified values. The Engineer may require up to the entire subplot of any mixture failing the Hamburg Wheel test or Overlay test to be removed and replaced at the Contractor's expense.
- 4.4.2.2.9. **Approval of JMF3 and Subsequent JMF Changes.** JMF3 and subsequent JMF changes are approved if they meet the master grading limits shown in Table 6, mixture requirements shown in Table 7, and are within the operational tolerances of JMF2 shown in Table 8.
- 4.5. **Production Operations.** Perform a new trial batch when the plant or plant location is changed. Take corrective action and receive approval to proceed after any production suspension for noncompliance to the specification.

4.5.1. **Storage and Heating of Materials.** Do not heat the asphalt binder above the temperatures specified in Item 300, "Asphalts, Oils, and Emulsions," or outside the manufacturer's recommended values. Provide the Engineer with daily records of asphalt binder and hot-mix asphalt discharge temperatures (in legible and discernible increments) in accordance with Item 320, "Equipment for Asphalt Concrete Pavement," unless otherwise directed. Do not store mixture for a period long enough to affect the quality of the mixture, nor in any case longer than 12 hr. unless otherwise approved.

4.5.2. **Mixing and Discharge of Materials.** Notify the Engineer of the target discharge temperature and produce the mixture within 25°F of the target. Monitor the temperature of the material in the truck before shipping to ensure that it does not exceed 350°F (or 275°F for WMA) and is not lower than 215°F. The Department will not pay for or allow placement of any mixture produced above 350°F.

Produce WMA within the target discharge temperature range of 215°F and 275°F when WMA is required. Take corrective action any time the discharge temperature of the WMA exceeds the target discharge range. The Engineer may suspend production operations if the Contractor's corrective action is not successful at controlling the production temperature within the target discharge range. Note that when WMA is produced, it may be necessary to adjust burners to ensure complete combustion such that no burner fuel residue remains in the mixture.

Control the mixing time and temperature so that substantially all moisture is removed from the mixture before discharging from the plant. Determine the moisture content, if requested, by oven-drying in accordance with Tex-212-F, Part II, and verify that the mixture contains no more than 0.2% of moisture by weight. Obtain the sample immediately after discharging the mixture into the truck, and perform the test promptly.

4.6. **Hauling Operations.** Clean all truck beds before use to ensure that mixture is not contaminated. Use a release agent shown on the Department's MPL to coat the inside bed of the truck when necessary.

Use equipment for hauling as defined in Section 347.4.7.3.3., "Hauling Equipment." Use other hauling equipment only when allowed.

4.7. **Placement Operations.** Collect haul tickets from each load of mixture delivered to the project and provide the Department's copy to the Engineer approximately every hour, or as directed. Use a hand-held thermal camera or infrared thermometer, when a thermal imaging system is not used, to measure and record the internal temperature of the mixture as discharged from the truck or Material Transfer Device (MTD) before or as the mix enters the paver and an approximate station number or GPS coordinates on each ticket. Calculate the daily yield and cumulative yield for the specified lift and provide to the Engineer at the end of paving operations for each day unless otherwise directed. The Engineer may suspend production if the Contractor fails to produce and provide haul tickets and yield calculations by the end of paving operations for each day.

Prepare the surface by removing raised pavement markers and objectionable material such as moisture, dirt, sand, leaves, and other loose impediments from the surface before placing mixture. Remove vegetation from pavement edges. Place the mixture to meet the typical section requirements and produce a smooth, finished surface with a uniform appearance and texture. Place mixture so that longitudinal joints on the surface course coincide with lane lines, or as directed. Ensure that all finished surfaces will drain properly. Place the mixture at the rate or thickness shown on the plans. The Engineer will use the guidelines in Table 9 to determine the compacted lift thickness. The thickness determined is based on the rate of 110–115 lb./sq. yd. for each inch of pavement unless otherwise shown on the plans.

Table 9
Compacted Lift Thickness

Mixture Type	Compacted Lift Thickness ¹	
	Minimum (in.)	Maximum (in.)
TOM-C	0.75	1.25
TOM-F	0.5	0.75

1. Compacted target lift thickness will be specified on the plans.

4.7.1. **Weather Conditions.**

4.7.1.1. **When Using a Thermal Imaging System.** The Contractor may pave any time the roadway is dry and the roadway surface temperature is at least 32°F; however, the Engineer may restrict the Contractor from paving surface mixtures if the ambient temperature is likely to drop below 32°F within 12 hr. of paving. Provide output data from the thermal imaging system to demonstrate to the Engineer that no recurring severe thermal segregation exists in accordance with Section 347.4.7.3.1.2., "Thermal Imaging System."

4.7.1.2. **When Not Using a Thermal Imaging System.** Place mixture when the roadway surface temperature is at or above 60°F unless otherwise approved. Measure the roadway surface temperature with a hand-held thermal camera or infrared thermometer. The Engineer may allow mixture placement to begin before the roadway surface reaches the required temperature requirements if conditions are such that the roadway surface will reach the required temperature within 1 hr. of beginning placement operations. Place mixtures only when weather conditions and moisture conditions of the roadway surface are suitable as determined by the Engineer. The Engineer may restrict the Contractor from paving if the air temperature is 70°F and falling.

Produce mixture with a Department approved WMA additive or process to facilitate compaction when the roadway surface temperature is below 60°F or when the air temperature is 60°F and falling. Produce the mixture with the WMA additive or process at a target discharge temperature higher than 300°F.

4.7.2. **Tack Coat.** Clean the surface before placing the tack coat. The Engineer will set the rate between 0.04 and 0.10 gal. of residual asphalt per square yard of surface area. Apply a uniform tack coat at the specified rate unless otherwise directed. Apply a uniform tack coat to all contact surfaces of curbs, structures, and all joints. Allow adequate time for emulsion to break completely before placing any material. Prevent splattering of tack coat when placed adjacent to curb, gutter, and structures. Roll the tack coat with a pneumatic-tire roller to remove streaks and other irregular patterns when directed. The Engineer may suspend paving operations until there is adequate coverage.

4.7.3. **Lay-Down Operations.**

4.7.3.1. **Thermal Profile.** Use a hand-held thermal camera or a thermal imaging system to obtain a continuous thermal profile in accordance with Tex-244-F.

4.7.3.1.1. **Thermal Segregation.**

4.7.3.1.1.1. **Moderate.** Any areas that have a temperature differential greater than 25°F, but not exceeding 50°F, are deemed as having moderate thermal segregation.

4.7.3.1.1.2. **Severe.** Any areas that have a temperature differential greater than 50°F are deemed as having severe thermal segregation.

4.7.3.1.2. **Thermal Imaging System.** Review the output results when a thermal imaging system is used, and provide the automated report described in Tex-244-F to the Engineer daily unless otherwise directed. Modify the paving process as necessary to eliminate any recurring (moderate or severe) thermal segregation identified by the thermal imaging system. The Engineer may suspend paving operations if the Contractor cannot successfully modify the paving process to eliminate recurring severe thermal segregation. Density profiles are not required and not applicable when using a thermal imaging system. Provide the Engineer with electronic copies of all daily data files that can be used with the thermal imaging system software to generate temperature profile plots upon completion of the project or as requested by the Engineer.

4.7.3.1.3. **Thermal Camera.** Take immediate corrective action to eliminate recurring moderate thermal segregation when a hand-held thermal camera is used. Evaluate areas with moderate thermal segregation by performing water flow testing in accordance to Tex-246-F and verify the water flow is greater than 120 sec. Provide the Engineer with the thermal profile of every subplot within one working day of the completion of each lot. Report the results of each thermal profile in accordance with Section 347.4.2., "Reporting and Responsibilities." The Engineer will use a hand-held thermal camera to obtain a thermal profile at least once per project. Suspend operations and take immediate corrective action to eliminate severe thermal segregation unless otherwise

directed. Resume operations when the Engineer determines that subsequent production will meet the requirements of this Section. Evaluate areas with severe thermal segregation by performing water flow testing in accordance to Tex-246-F and verify the water flow is greater than 120 sec. Remove and replace the material in any areas that have both severe thermal segregation and a failing result for water flow test unless otherwise directed.

- 4.7.3.2. **Windrow Operations.** Operate windrow pickup equipment so that when hot-mix is placed in windrows, substantially all the mixture deposited on the roadbed is picked up and loaded into the paver.
- 4.7.3.3. **Hauling Equipment.** Use belly dumps, live bottom, or end dump trucks to haul and transfer mixture. End dump trucks are only allowed when used in conjunction with an MTD with remixing capability unless otherwise allowed.
- 4.7.3.4. **Screed Heaters.** Turn off screed heaters to prevent overheating of the mat if the paver stops for more than 5 min. The Engineer may evaluate the suspect area in accordance with Section 347.4.9.3.1.1., "Recovered Asphalt Dynamic Shear Rheometer (DSR)," if the screed heater remains on for more than 5 min. while the paver is stopped.
- 4.8. **Compaction.** Roll the freshly placed mixture with a steel-wheeled roller without excessive breakage of the aggregate to provide a smooth surface and uniform texture. Operate the roller in static mode for TOM-F mixtures only. Do not use pneumatic-tire rollers. Use the control strip method given in Tex-207-F, Part IV, to establish the rolling pattern. Thoroughly moisten the roller drums with a soap and water solution to prevent adhesion. Use only water or an approved release agent on rollers, tamps, and other compaction equipment unless otherwise directed.

Use tamps to thoroughly compact the edges of the pavement along curbs, headers, and similar structures and in locations that will not allow thorough compaction with rollers. The Engineer may require rolling with a trench roller on widened areas, in trenches, and in other limited areas.

Use Tex-246-F to measure water flow to verify the mixture is adequately compacted. Measure the water flow once per subplot at locations directed by the Engineer. Take additional water flow measurements when both of the following conditions occur:

- the temperature of the mixture before compaction is below 275°F; and
- WMA is not used.

The water flow rate should be greater than 120 sec. Adjust the mix design or construction methods, when directed, if the water flow rate is less than 120 sec.

Allow the compacted pavement to cool to 160°F or lower before opening to traffic unless otherwise directed. Sprinkle the finished mat with water or limewater, when directed, to expedite opening the roadway to traffic.

- 4.9. **Acceptance Plan.** Sample and test the hot-mix asphalt on a lot and subplot basis. Suspend production if production test results fail to meet the operational tolerance requirements in Table 8 for any material property for 4 consecutive sublots until test results or other information indicates to the satisfaction of the Engineer that the next material produced or placed will meet specification requirements.
- 4.9.1. **Referee Testing.** The Construction Division is the referee laboratory. The Contractor may request referee testing if the differences between Contractor and Engineer test results exceed the maximum allowable difference shown in Table 8 and the differences cannot be resolved. The Contractor may also request referee testing if the Engineer's test results require suspension of production and the Contractor's test results are within specification limits. Make the request within 5 working days after receiving test results from the Engineer. Referee tests will be performed only on the subplot in question and only for the particular tests in question. Allow 10 working days from the time the referee laboratory receives the samples for test results to be reported. The Department may require the Contractor to reimburse the Department for referee tests if more than 3 referee tests per project are required and the Engineer's test results are closer to the referee test results than the Contractor's test results.

The Construction Division will determine the laboratory-molded density based on the molded specific gravity and the maximum theoretical specific gravity of the referee sample.

4.9.2. **Production Acceptance.**

4.9.2.1. **Production Lot.** A production lot consists of 4 equal sublots. The default quantity for Lot 1 is 500 tons; however, when requested by the Contractor, the Engineer may increase the quantity for Lot 1 to no more than 2,000 tons. The Engineer will select subsequent lot sizes based on the anticipated daily production such that approximately 3 to 4 sublots are produced each day. The lot size will be between 500 tons and 2,000 tons. The Engineer may change the lot size before the Contractor begins any lot.

4.9.2.1.1. **Incomplete Production Lots.** If a lot is begun but cannot be completed, such as on the last day of production or in other circumstances deemed appropriate, the Engineer may close the lot. Close all lots within 5 working days unless otherwise allowed.

4.9.2.2. **Production Sampling.**

4.9.2.2.1. **Mixture Sampling.** Obtain hot-mix samples from trucks at the plant in accordance with Tex-222-F. The sampler will split each sample into 3 equal portions in accordance with Tex-200-F and label these portions as "Contractor," "Engineer," and "Referee." The Engineer will perform or witness the sample splitting and take immediate possession of the samples labeled "Engineer" and "Referee." The Engineer will maintain the custody of the samples labeled "Engineer" and "Referee" until the Department's testing is completed.

4.9.2.2.1.1. **Random Sample.** At the beginning of the project, the Engineer will select random numbers for all production sublots. Determine sample locations in accordance with Tex-225-F. Take one sample for each subplot at the randomly selected location. The Engineer will perform or witness the sampling of production sublots.

4.9.2.2.1.2. **Blind Sample.** For one subplot per lot, the Engineer will obtain and test a "blind" sample instead of the random sample collected by the Contractor. Test either the "blind" or the random sample; however, referee testing (if applicable) will be based on a comparison of results from the "blind" sample. The location of the Engineer's "blind" sample will not be disclosed to the Contractor. The Engineer's "blind" sample may be randomly selected in accordance with Tex-225-F for any subplot or selected at the discretion of the Engineer. The Engineer will use the Contractor's split sample for sublots not sampled by the Engineer.

4.9.2.2.2. **Asphalt Binder Sampling.** Obtain a 1-qt. sample of the asphalt binder for each lot of mixture produced. Obtain the sample at approximately the same time the mixture random sample is obtained. Sample from a port located immediately upstream from the mixing drum or pug mill in accordance with Tex-500-C, Part II. Label the can with the corresponding lot and subplot numbers, and deliver the sample to the Engineer. The Engineer may also obtain independent samples. If obtaining an independent asphalt binder sample, the Engineer will split a sample of the asphalt binder with the Contractor. The Engineer will test at least one asphalt binder sample per project to verify compliance with Item 300, "Asphalts, Oils, and Emulsions."

4.9.2.3. **Production Testing.** The Contractor and Engineer must perform production tests in accordance with Table 10. The Contractor has the option to verify the Engineer's test results on split samples provided by the Engineer. Determine compliance with operational tolerances listed in Table 8 for all sublots.

Take immediate corrective action if the Engineer's laboratory-molded density on any subplot is less than 95.0% or greater than 98.0% when using the SGC or less than 96.5% or greater than 98.5%, to bring the mixture within these tolerances. The Engineer may suspend operations if the Contractor's corrective actions do not produce acceptable results. The Engineer will allow production to resume when the proposed corrective action is likely to yield acceptable results.

The Engineer may allow alternate methods for determining the asphalt binder content and aggregate gradation if the aggregate mineralogy is such that Tex-236-F does not yield reliable results. Provide evidence that results from Tex-236-F are not reliable before requesting permission to use an alternate method unless otherwise directed. Use the applicable test procedure as directed if an alternate test method is allowed.

Table 10
Production and Placement Testing Frequency

Description	Test Method	Minimum Contractor Testing Frequency	Minimum Engineer Testing Frequency
Individual % retained for #8 sieve and larger	Tex-200-F or Tex-236-F	1 per subplot	1 per 12 sublots
Individual % retained for sieves smaller than #8 and larger than #200			
% passing the #200 sieve			
Laboratory-molded density	Tex-207-F	N/A	1 per subplot
Laboratory-molded bulk specific gravity			
VMA			
Moisture content	Tex-212-F, Part II	When directed	
Theoretical maximum specific (Rice) gravity	Tex-227-F	N/A	1 per subplot
Asphalt binder content	Tex-236-F	1 per subplot	1 per lot
Overlay test ¹	Tex-248-F	N/A	1 per project
Cantabro loss ¹	Tex-245-F	N/A	1 per project
Hamburg Wheel test	Tex-242-F	N/A	1 per project
Thermal profile	Tex-244-F	1 per subplot	
Asphalt binder sampling and testing ¹	Tex-500-C	1 per subplot (sample only)	
Boil test ²	Tex-530-C	1 per subplot	
Water flow	Tex-246-F		

1. Testing performed by the Construction Division or as directed by the Engineer. Cantabro Loss is for informational purposes only.
2. The Engineer may reduce or waive the sampling and testing requirements based on a satisfactory test history.

4.9.2.4. **Operational Tolerances.** Control the production process within the operational tolerances listed in Table 8. When production is suspended, the Engineer will allow production to resume when test results or other information indicates the next mixture produced will be within the operational tolerances.

4.9.2.4.1. **Gradation.** Suspend operation and take corrective action if any aggregate is retained on the maximum sieve size shown in Table 6. A subplot is defined as out of tolerance if either the Engineer's or the Contractor's test results are out of operational tolerance. Suspend production when test results for gradation exceed the operational tolerances for 3 consecutive sublots on the same sieve or 4 consecutive sublots on any sieve unless otherwise directed. The consecutive sublots may be from more than one lot.

4.9.2.4.2. **Asphalt Binder Content.** A subplot is defined as out of operational tolerance if either the Engineer's or the Contractor's test results exceed the values listed in Table 8. Suspend production when 2 or more sublots within a lot are out of operational tolerance or below the minimum asphalt binder content specified in Table 6 unless otherwise directed. Suspend production and shipment of mixture if the Engineer's or Contractor's asphalt binder content deviates from the current JMF by more than 0.5% for any subplot.

4.9.2.4.3. **Voids in Mineral Aggregates (VMA).** The Engineer will determine the VMA for every subplot. For sublots when the Engineer does not determine asphalt binder content, the Engineer will use the asphalt binder content results from QC testing performed by the Contractor to determine VMA.

Take immediate corrective action if the VMA value for any subplot is less than the minimum VMA requirement for production listed in Table 6. Suspend production and shipment of the mixture if the Engineer's VMA results on 2 consecutive sublots are below the minimum VMA requirement for production listed in Table 6.

Suspend production and shipment of the mixture if the Engineer's VMA result is more than 0.5% below the minimum VMA requirement for production listed in Table 6. In addition to suspending production, the Engineer may require removal and replacement or may allow the subplot to be left in place without payment.

4.9.2.4.4. **Hamburg Wheel and Overlay Test.** The Engineer may perform a Hamburg Wheel or Overlay test at any time during production, including when the boil test indicates a change in quality from the materials submitted for JMF1. The Engineer may obtain cores and perform the Hamburg Wheel test on any area of the roadway where rutting is observed in addition to testing production samples. Suspend production until further Hamburg Wheel or Overlay tests meet the specified values when the production or core samples fail to meet

the Hamburg Wheel or Overlay test criteria in Table 7. Core samples, if taken, will be obtained from the center of the finished mat or other areas excluding the vehicle wheel paths. The Engineer may require up to the entire subplot of any mixture failing the Hamburg Wheel or Overlay test to be removed and replaced at the Contractor's expense.

If the Department's Hamburg Wheel or Overlay test or Department-approved laboratory's Hamburg Wheel test results in a "remove and replace" condition, the Contractor may request that the Department confirm the results by re-testing the failing material. The Construction Division will perform the Hamburg Wheel and Overlay tests and determine the final disposition of the material in question based on the Department's test results.

4.9.2.5. **Individual Loads of Hot-Mix.** The Engineer can reject individual truckloads of hot-mix. When a load of hot-mix is rejected for reasons other than temperature, contamination, or excessive uncoated particles, the Contractor may request that the rejected load be tested. Make this request within 4 hr. of rejection. The Engineer will sample and test the mixture. If test results are within the operational tolerances shown in Table 8, payment will be made for the load. If test results are not within operational tolerances, no payment will be made for the load.

4.9.3. **Placement Acceptance.**

4.9.3.1. **Placement Lot.** A placement lot consists of 4 placement sublots. A placement subplot consists of the area placed during a production subplot.

4.9.3.1.1. **Recovered Asphalt Dynamic Shear Rheometer (DSR).** The Engineer may take production samples or cores from suspect areas of the project to determine recovered asphalt properties. Asphalt binders with an aging ratio greater than 3.5 do not meet the requirements for recovered asphalt properties and may be deemed defective when tested and evaluated by the Construction Division. The aging ratio is the DSR value of the extracted binder divided by the DSR value of the original unaged binder. Obtain DSR values in accordance with AASHTO T 315 at the specified high temperature performance grade of the asphalt. The Engineer may require removal and replacement of the defective material at the Contractor's expense. The asphalt binder will be recovered for testing from production samples or cores in accordance with Tex-211-F.

4.9.3.1.2. **Irregularities.** Identify and correct irregularities including segregation, rutting, raveling, flushing, fat spots, mat slippage, irregular color, irregular texture, roller marks, tears, gouges, streaks, uncoated aggregate particles, or broken aggregate particles. The Engineer may also identify irregularities, and in such cases, the Engineer will promptly notify the Contractor. The Engineer may require the Contractor to remove and replace (at the Contractor's expense) areas of the pavement that contain irregularities and areas where the mixture does not bond to the existing pavement if the Engineer determines that the irregularity will adversely affect pavement performance. The Engineer may require the Contractor to immediately suspend operations if irregularities are detected or may allow the Contractor to continue operations for no more than one day while the Contractor is taking appropriate corrective action.

4.9.4. **Exempt Production.** When the anticipated daily production is less than 100 tons, all QC and QA sampling and testing are waived. The Engineer may deem the mixture as exempt production for the following conditions:

- anticipated daily production is more than 100 tons but less than 250 tons;
- total production for the project is less than 2,500 tons;
- when mutually agreed between the Engineer and the Contractor; or
- when shown on the plans.

For exempt production, the Contractor is relieved of all production and placement sampling and testing requirements. All other specification requirements apply, and the Engineer will perform acceptance tests for production and placement listed in Table 10.

For exempt production:

- produce, haul, place, and compact the mixture as directed by the Engineer; and
- control mixture production to yield a laboratory-molded density that is within $\pm 1.0\%$ of the target density as tested by the Engineer.

- 4.9.5. **Ride Quality.** Measure ride quality in accordance with Item 585, "Ride Quality for Pavement Surfaces," unless otherwise shown on the plans.

5. MEASUREMENT

TOM will be measured by the ton of composite mixture. The composite mixture is defined as the asphalt, aggregate, and additives. The weights of asphalt and aggregate will be calculated based on the measured weight of TOM and the target percentage of asphalt and aggregate. Measure the weight on scales in accordance with Item 520, "Weighing and Measuring Equipment."

- 5.1. **Asphalt.** The asphalt weight in tons will be determined from the total weight of TOM. Measured asphalt percentage will be obtained using Tex-236-F or asphalt flow meter readings, as determined by the Engineer. Provide the Engineer with a daily summary of the asphalt mass flow meter readings when used for measuring asphalt percentage unless otherwise directed.
- 5.1.1. **Target Percentage.** The JMF target asphalt percentage will be used to calculate the weight of asphalt binder unless the measured asphalt binder percentage is more than 0.3 percentage points below the JMF target asphalt percentage or less than the minimum percentage specified in Table 6. Volumetric meter readings will be adjusted to 140°F and converted to weight.
- 5.1.2. **Measured Percentage.** The average measured asphalt percentage from each subplot will be used for payment for that lot's production when the measured percentage for any subplot is more than 0.3 percentage points below the JMF target asphalt percentage or less than the minimum percentage specified in Table 6.
- 5.2. **Aggregate.** The aggregate weight in tons will be determined from the total weight of TOM less the weight of the asphalt.

6. PAYMENT

The work performed and materials furnished in accordance with this Item and measured as provided under Section 347.5., "Measurement," will be paid for at the unit bid price for "TOM (Asphalt)" of the binder specified and for "TOM (Aggregate)" of the grade and SAC specified. These prices are full compensation for surface preparation, materials including tack coat, placement, equipment, labor, tools, and incidentals.

Trial batches will not be paid for unless they are included in pavement work approved by the Department.

Payment adjustment for ride quality will be determined in accordance with Item 585, "Ride Quality for Pavement Surfaces."

Item 348

Thin Bonded Friction Courses



1. DESCRIPTION

Construct a hot-mix asphalt (HMA) surface course composed of a warm spray-applied polymer modified emulsion membrane followed immediately with a compacted permeable mixture of aggregate, asphalt binder, and additives mixed hot in a mixing plant.

2. MATERIALS

Furnish uncontaminated materials of uniform quality that meet the requirements of the plans and specifications.

Notify the Engineer of all material sources and before changing any material source or formulation. The Engineer will verify that the specification requirements are met when the Contractor makes a source or formulation change, and may require a new laboratory mixture design, trial batch, or both. The Engineer may sample and test project materials at any time during the project to verify specification compliance in accordance with Item 6, "Control of Materials."

- 2.1. **Aggregate.** Furnish aggregates from sources that conform to the requirements shown in Table 1 and as specified in this Section. Aggregate requirements in this Section, including those shown in Table 1, may be modified or eliminated when shown on the plans. Additional aggregate requirements may be specified when shown on the plans. Provide aggregate stockpiles that meet the definitions in this Section for coarse or fine aggregate. Do not use intermediate or fine aggregate in PFC mixtures. Aggregate from reclaimed asphalt pavement (RAP) is not required to meet Table 1 requirements unless otherwise shown on the plans. Supply aggregates that meet the definitions in Tex-100-E for crushed gravel or crushed stone. The Engineer will designate the plant or the quarry as the sampling location. Provide samples from materials produced for the project. The Engineer will establish the Surface Aggregate Classification (SAC) and perform Los Angeles abrasion, magnesium sulfate soundness, and Micro-Deval tests. Perform all other aggregate quality tests listed in Table 1. Document all test results on the mixture design report. The Engineer may perform tests on independent or split samples to verify Contractor test results. Stockpile aggregates for each source and type separately. Determine aggregate gradations for mixture design and production testing based on the washed sieve analysis given in Tex-200-F, Part II.

- 2.1.1. **Coarse Aggregate.** Coarse aggregate stockpiles must have no more than 20% material passing the No. 8 sieve. Aggregates from sources listed in the Department's *Bituminous Rated Source Quality Catalog* (BRSQC) are preapproved for use. Use only the rated values for hot-mix listed in the BRSQC. Rated values for surface treatment (ST) do not apply to coarse aggregate sources used in hot-mix asphalt.

For sources not listed on the Department's BRSQC:

- build an individual stockpile for each material;
- request the Department test the stockpile for specification compliance; and
- once approved, do not add material to the stockpile unless otherwise approved.

Provide aggregate from non-listed sources only when tested by the Engineer and approved before use. Allow 30 calendar days for the Engineer to sample, test, and report results for non-listed sources.

Provide coarse aggregate with at least the minimum SAC shown on the plans. SAC requirements only apply to aggregates used on the surface of travel lanes. SAC requirements apply to aggregates used on surfaces other than travel lanes when shown on the plans. The SAC for sources on the Department's *Aggregate Quality Monitoring Program* (AQMP) (Tex-499-A) is listed in the BRSQC.

- 2.1.1.1. **Blending Class A and Class B Aggregates.** Class B aggregate meeting all other requirements in Table 1 may be blended with a Class A aggregate to meet requirements for Class A materials; however, Class B virgin (non-recycled) aggregate may be disallowed when shown on the plans. Ensure that at least 50% by weight, or volume if required, of the material retained on the No. 4 sieve comes from the Class A aggregate source when blending Class A and B aggregates to meet a Class A requirement. Blend by volume if the bulk specific gravities of the Class A and B aggregates differ by more than 0.300. Coarse aggregate from RAP and Recycled Asphalt Shingles (RAS) will be considered as Class B aggregate for blending purposes.

The Engineer may perform tests at any time during production, when the Contractor blends Class A and B aggregates to meet a Class A requirement, to ensure that at least 50% by weight, or volume if required, of the material retained on the No. 4 sieve comes from the Class A aggregate source. The Engineer will use the Department's mix design template, when electing to verify conformance, to calculate the percent of Class A aggregate retained on the No. 4 sieve by inputting the bin percentages shown from readouts in the control room at the time of production and stockpile gradations measured at the time of production. The Engineer may determine the gradations based on either washed or dry sieve analysis from samples obtained from individual aggregate cold feed bins or aggregate stockpiles. The Engineer may perform spot checks using the gradations supplied by the Contractor on the mixture design report as an input for the template; however, a failing spot check will require confirmation with a stockpile gradation determined by the Engineer.

- 2.1.1.2. **Micro-Deval Abrasion.** The Engineer will perform a minimum of one Micro-Deval abrasion test in accordance with Tex-461-A for each coarse aggregate source used in the mixture design that has a Rated Source Soundness Magnesium (RSSM) loss value greater than 15 as listed in the BRSQC. The Engineer will perform testing before the start of production and may perform additional testing at any time during production. The Engineer may obtain the coarse aggregate samples from each coarse aggregate source or may require the Contractor to obtain the samples. The Engineer may waive all Micro-Deval testing based on a satisfactory test history of the same aggregate source.

The Engineer will estimate the magnesium sulfate soundness loss for each coarse aggregate source, when tested, using the following formula:

$$Mg_{est.} = (RSSM)(MD_{act.}/RSMD)$$

where:

$Mg_{est.}$ = magnesium sulfate soundness loss

$MD_{act.}$ = actual Micro-Deval percent loss

$RSMD$ = Rated Source Micro-Deval

When the estimated magnesium sulfate soundness loss is greater than the maximum magnesium sulfate soundness loss specified, the coarse aggregate source will not be allowed for use unless otherwise approved. The Engineer will consult the Geotechnical, Soils, and Aggregates Branch of the Construction Division, and additional testing may be required before granting approval.

- 2.1.2. **Fine Aggregate.** Fine aggregates consist of manufactured sands and screenings. Fine aggregate stockpiles must meet the gradation requirements in Table 2. Supply fine aggregates that are free from organic impurities. The Engineer may test the fine aggregate in accordance with Tex-408-A to verify the material is free from organic impurities. Do not use field sand or other uncrushed fine aggregate. Use fine aggregate from coarse aggregate sources that meet the requirements shown in Table 1 unless otherwise approved.

Table 1
Coarse Aggregate Quality Requirements

Property	Test Method	Requirement
SAC	Tex-499-A (AQMP)	As shown on the plans
Deleterious material, %, Max	Tex-217-F, Part I	1.0
Decantation, %, Max	Tex-217-F, Part II	1.5
Micro-Deval abrasion, %	Tex-461-A	Note ¹
Los Angeles abrasion, %, Max	Tex-410-A	30
Magnesium sulfate soundness, 5 cycles, %, Max	Tex-411-A	20
Crushed face count ² , %, Min	Tex-460-A, Part I	95
Flat and elongated particles @ 5:1, %, Max	Tex-280-F	10
Fine Aggregate Properties		
Sand Equivalent, %, Min	Tex-203-F	45
Methylene Blue, Max	AASHTO TP57-99	10

1. Used to estimate the magnesium sulfate soundness loss in accordance with Section 348.2.1.1.2., "Micro-Deval Abrasion."

2. Only applies to crushed gravel.

Table 2
Gradation Requirements for Fine Aggregate

Sieve Size	% Passing by Weight or Volume
3/8"	100
#8	70–100
#200	0–30

2.2. **Mineral Filler.** Mineral filler consists of finely divided mineral matter such as agricultural lime, crusher fines, hydrated lime, or fly ash. Mineral filler is allowed unless otherwise shown on the plans. Use no more than 2% hydrated lime or fly ash, unless otherwise shown on the plans. The plans may require or disallow specific mineral fillers. Provide mineral filler, when used, that:

- is sufficiently dry, free-flowing, and free from clumps and foreign matter as determined by the Engineer;
- does not exceed 3% linear shrinkage when tested in accordance with Tex-107-E; and
- meets the gradation requirements in Table 3.

Table 3
Gradation Requirements for Mineral Filler

Sieve Size	% Passing by Weight or Volume
#8	100
#200	55–100

2.3. **Baghouse Fines.** Fines collected by the baghouse or other dust-collecting equipment may be reintroduced into the mixing drum.

2.4. **Asphalt Binder.** Furnish the type and grade of binder specified on the plans that meets the requirements of Item 300, "Asphalts, Oils, and Emulsions."

2.4.1. **Performance-Graded (PG) Binder.** Provide an asphalt binder with a high-temperature grade of PG 76 and low-temperature grade as shown on the plans in accordance with Section 300.2.10., "Performance-Graded Binders," when PG binder is specified.

2.4.2. **Asphalt-Rubber (A-R) Binder.** Provide A-R binder that meets the Type I or Type II requirements of Section 300.2.9., "Asphalt-Rubber Binders," when A-R is specified unless otherwise shown on the plans. Use at least 15.0% by weight of Crumb Rubber Modifier (CRM) that meets the Grade B or Grade C requirements of Section 300.2.7., "Crumb Rubber Modifier," unless otherwise shown on the plans. Provide the Engineer the A-R binder blend design with the mix design (JMF1) submittal. Provide the Engineer with documentation such as the bill of lading showing the quantity of CRM used in the project unless otherwise directed.

2.5. **Membrane.** Provide a smooth and homogeneous polymer modified emulsion meeting the requirements of Table 4.

Table 4
Polymer Modified Emulsion Requirements

Test on Emulsion	Test Method	Min	Max
Viscosity @ 77°F, SSF	T 72	20	100
Storage Stability, ¹ %	T 59		1
Demulsibility (for anionic emulsions), 35 mL of 0.02 N CaCl ₂ , %	T 59	55	
Demulsibility (for cationic emulsions), 35 mL 0.8% Sodium dioctyl sulfosuccinate, %	T 59	55	
Sieve Test, ² %	T 59		0.05
Distillation Test: ³ Residue by distillation, % by wt. Oil portion of distillate, % by vol.	T 59	63	0.5
Test on Residue from Distillation	Test Method	Min	Max
Elastic Recovery @ 50°F, 50 mm/min., %	Tex-539-C	60	
Penetration @ 77°F, 100 g, 5 sec, 0.1 mm	T 49	100	150

1. After standing undisturbed for 24 hours, the surface must be smooth, must not exhibit a white or milky colored substance, and must be a homogeneous color throughout.
2. May be required by the Engineer only when the emulsion cannot be easily applied in the field.
3. The temperature on the lower thermometer should be brought slowly to 350°F ±10°F and maintained at this temperature for 20 minutes. The total distillation should be complete in 60 ±5 min. from the first application of heat.

- 2.6. **Additives.** Use the type and rate of additive specified when shown on the plans. Additives that facilitate mixing, compaction, or improve the quality of the mixture are allowed when approved. Provide the Engineer with documentation such as the bill of lading showing the quantity of additives used in the project unless otherwise directed.
- 2.6.1. **Fibers.** Provide cellulose or mineral fibers when PG binder is specified. Do not use fibers when A-R binder is specified. Submit written certification to the Engineer that the fibers proposed for use meet the requirements of DMS-9204, "Fiber Additives for Bituminous Mixtures." Fibers may be pre-blended into the binder at the asphalt supply terminal unless otherwise shown on the plans. The Contractor may reduce the amount of fibers when at least 3% RAS is used in the mixture, as specified in Table 8, Note 3.
- 2.6.2. **Lime Mineral Filler.** Add lime as mineral filler at a rate of 1.0% by weight of the total dry aggregate in accordance with Item 301, "Asphalt Antistripping Agents," unless otherwise shown on the plans or waived by the Engineer based on Hamburg Wheel test results. Do not add lime directly into the mixing drum of any plant where lime is removed through the exhaust stream unless the plant has a baghouse or dust collection system that reintroduces the lime into the drum.
- 2.6.3. **Lime and Liquid Antistripping Agent.** When lime or a liquid antistripping agent is used, add in accordance with Item 301, "Asphalt Antistripping Agents." Do not add lime directly into the mixing drum of any plant where lime is removed through the exhaust stream unless the plant has a baghouse or dust collection system that reintroduces the lime into the drum. Lime added as mineral filler will count towards the total quantity of lime specified when the plans require lime to be added as an antistripping agent.
- 2.6.4. **Warm Mix Asphalt (WMA).** Warm Mix Asphalt (WMA) is defined as HMA that is produced within a target temperature discharge range of 215°F and 275°F using approved WMA additives or processes from the Department's MPL.

WMA is allowed for use on all projects and is required when shown on the plans. When WMA is required, the maximum placement or target discharge temperature for WMA will be set at a value below 275°F.

Department-approved WMA additives or processes may be used to facilitate mixing and compaction of HMA produced at target discharge temperatures above 275°F; however, such mixtures will not be defined as WMA.

2.7. **Recycled Materials.** Use of RAP and RAS is permitted unless otherwise shown on the plans. Do not exceed the maximum allowable percentages of RAP and RAS shown in Table 5. The allowable percentages shown in Table 5 may be decreased or increased when shown on the plans. Determine asphalt binder content and gradation of the RAP and RAS stockpiles for mixture design purposes in accordance with Tex-236-F. The Engineer may verify the asphalt binder content of the stockpiles at any time during production. Perform other tests on RAP and RAS when shown on the plans. Asphalt binder from RAP and RAS is designated as recycled asphalt binder. Calculate and ensure that the ratio of the recycled asphalt binder to total binder does not exceed the percentages shown in Table 5 during mixture design and HMA production when RAP or RAS is used. Use a separate cold feed bin for each stockpile of RAP and RAS during HMA production.

2.7.1. **RAP.** RAP is salvaged, milled, pulverized, broken, or crushed asphalt pavement. Crush or break RAP so that 100% of the particles pass the 2 in. sieve. Fractionated RAP is defined as 2 or more RAP stockpiles, divided into coarse and fine fractions.

Use of Contractor-owned RAP including HMA plant waste is permitted unless otherwise shown on the plans. Department-owned RAP stockpiles are available for the Contractor's use when the stockpile locations are shown on the plans. If Department-owned RAP is available for the Contractor's use, the Contractor may use Contractor-owned fractionated RAP and replace it with an equal quantity of Department-owned RAP. Unfractionated RAP is not allowed in PFC mixtures. Department-owned RAP generated through required work on the Contract is available for the Contractor's use when shown on the plans. Perform any necessary tests to ensure Contractor- or Department-owned RAP is appropriate for use. The Department will not perform any tests or assume any liability for the quality of the Department-owned RAP unless otherwise shown on the plans. The Contractor will retain ownership of RAP generated on the project when shown on the plans.

The coarse RAP stockpile will contain only material retained by processing over a 3/8-in. screen unless otherwise approved. Fine RAP is not allowed in PFC mixtures. The Engineer may allow the Contractor to use an alternate to the 3/8-in. screen to fractionate the RAP.

Do not use Department- or Contractor-owned RAP contaminated with dirt or other objectionable materials.

Do not intermingle Contractor-owned RAP stockpiles with Department-owned RAP stockpiles. Remove unused Contractor-owned RAP material from the project site upon completion of the project. Return unused Department-owned RAP to the designated stockpile location.

2.7.2. **RAS.** Use of post-manufactured RAS or post-consumer RAS (tear-offs) is permitted unless otherwise shown on the plans. RAS is defined as processed asphalt shingle material from manufacturing of asphalt roofing shingles or from re-roofing residential structures. Post-manufactured RAS is processed manufacturer's shingle scrap by-product. Post-consumer RAS is processed shingle scrap removed from residential structures. Comply with all regulatory requirements stipulated for RAS by the TCEQ. RAS may be used separately or in conjunction with RAP.

Process the RAS by ambient grinding or granulating such that 100% of the particles pass the 3/8 in. sieve when tested in accordance with Tex-200-F, Part I. Perform a sieve analysis on processed RAS material before extraction (or ignition) of the asphalt binder.

Any stockpile that contains RAS will be considered a RAS stockpile and be limited to no more than 5.0% of the HMA mixture in accordance with Table 5.

Certify compliance of the RAS with DMS-11000, "Evaluating and Using Nonhazardous Recyclable Materials Guidelines." Treat RAS as an established nonhazardous recyclable material if it has not come into contact with any hazardous materials. Use RAS from shingle sources on the Department's MPL. Remove substantially all materials before use that are not part of the shingle, such as wood, paper, metal, plastic, and felt paper. Determine the deleterious content of RAS material for mixture design purposes in accordance with Tex-217-F, Part III. Do not use RAS if deleterious materials are more than 0.5% of the stockpiled RAS unless otherwise approved. Submit a sample for approval before submitting the mixture design. The Department will perform the testing for deleterious material of RAS to determine specification compliance.

Table 5
Maximum Allowable Amounts of Recycled Binder, RAP, and RAS

Maximum Ratio of Recycled Binder to Total Binder ¹ (%)	Maximum Allowable Recycled Material ² (%)	
	Fractionated RAP ³	RAS ⁴
15.0	10.0	5.0

1. Combined recycled binder from fractionated RAP and RAS.
2. Unfractionated RAP is not allowed in PFC mixtures.
3. May replace up to 5% fractionated RAP with RAS.
4. May be used separately or as a replacement for no more than 5% of the allowable fractionated RAP.

3. EQUIPMENT

Provide required or necessary equipment in accordance with Item 320, "Equipment for Asphalt Concrete Pavement." When A-R binder is specified, equip the hot-mix plant with an in-line viscosity-measuring device located between the blending unit and the mixing drum. Provide a means to calibrate the asphalt mass flow meter on-site when a meter is used.

3.1. **Placement Equipment.** Provide a paver that meets all the requirements listed below.

3.1.1. **Paver.** Furnish a paver that will spray the membrane, apply the PFC mixture, and level the surface of the mat in a single pass. Configure the paver so that the mixture is placed no more than 5 sec. after the membrane is applied. Ensure the paver does not support the weight of any portion of hauling equipment other than the connection. Provide loading equipment that does not transmit vibrations or other motions to the paver that adversely affects the finished pavement quality. Equip the paver with an automatic dual longitudinal-grade control system and an automatic transverse-grade control system.

3.1.1.1. **Tractor Unit.** Supply a tractor unit that can push or propel vehicles, dumping directly into the finishing machine to obtain the desired lines and grades to eliminate any hand finishing. Equip the unit with a hitch sufficient to maintain contact between the hauling equipment's rear wheels and the finishing machine's pusher rollers while mixture is unloaded.

3.1.1.2. **Membrane Storage Tank and Distribution System.** Equip the paver with an insulated storage tank with a minimum capacity of 900 gal. Provide a metered mechanical pressure sprayer on the paver to apply a uniform membrane at the specified rate. Locate the spray bar on the paver so that the membrane is applied immediately in front of the screed unit. Provide a read out device on the paver to monitor the membrane application rate.

Furnish a volumetric calibration and strap stick for the tank in accordance with Tex-922-K, Part I, unless otherwise directed. Calibrate the tank within the previous 5 yr. of the date first used on the project. The Engineer may verify calibration accuracy in accordance with Tex-922-K, Part II.

3.1.1.3. **Screed.** Provide a variable width vibratory screed that meets Item 320, "Equipment for Asphalt Concrete Pavement."

3.1.2. **Material Transfer Device (MTD).** Provide the specified type of MTD when shown on the plans. Ensure MTDs provide a continuous, uniform mixture flow to the asphalt paver.

3.1.3. **Rollers.** Provide steel-wheel rollers meeting the requirements of Item 210, "Rolling," except provide rollers weighing a minimum of 10 tons for each roller required. Operate rollers in static (non-vibrating) mode unless otherwise allowed.

4. CONSTRUCTION

Produce, haul, place, and compact the specified paving mixture. In addition to tests required by the specification, Contractors may perform other QC tests as deemed necessary. At any time during the project, the Engineer may perform production and placement tests as deemed necessary in accordance with Item 5,

"Control of the Work." Schedule and participate in a mandatory pre-paving meeting with the Engineer on or before the first day of paving unless otherwise shown on the plans.

- 4.1. **Certification.** Personnel certified by the Department-approved hot-mix asphalt certification program must conduct all mixture designs, sampling, and testing in accordance with Table 6. Supply the Engineer with a list of certified personnel and copies of their current certificates before beginning production and when personnel changes are made. Provide a mixture design developed and signed by a Level 2 certified specialist. Provide Level 1A certified specialists at the plant during production operations. Provide Level 1B certified specialists to conduct placement tests.

Table 6
Test Methods, Test Responsibility, and Minimum Certification Levels

Test Description	Test Method	Contractor	Engineer	Level ¹
1. Aggregate and Recycled Material Testing				
Sampling	Tex-221-F	✓	✓	1A
Dry sieve	Tex-200-F, Part I	✓	✓	1A
Washed sieve	Tex-200-F, Part II	✓	✓	1A
Deleterious material	Tex-217-F, Parts I & III	✓	✓	1A
Decantation	Tex-217-F, Part II	✓	✓	1A
Los Angeles abrasion	Tex-410-A		✓	TxDOT
Magnesium sulfate soundness	Tex-411-A		✓	TxDOT
Micro-Deval abrasion	Tex-461-A		✓	2
Crushed face count	Tex-460-A	✓	✓	2
Flat and elongated particles	Tex-280-F	✓	✓	2
2. Asphalt Binder & Tack Coat Sampling				
Asphalt binder sampling	Tex-500-C, Part II	✓	✓	1A/1B
Membrane sampling	Tex-500-C, Part III	✓	✓	1A/1B
3. Mix Design & Verification				
Design and JMF changes	Tex-204-F	✓	✓	2
Mixing	Tex-205-F	✓	✓	2
Molding (SGC)	Tex-241-F	✓	✓	1A
Laboratory-molded density	Tex-207-F	✓	✓	1A
Rice gravity	Tex-227-F	✓	✓	1A
Ignition oven correction factors ²	Tex-236-F	✓	✓	2
Drain-down	Tex-235-F	✓	✓	1A
Hamburg Wheel test	Tex-242-F	✓	✓	2
Overlay test	Tex-248-F		✓	TxDOT
Boil test	Tex-530-C	✓	✓	1A
Cantabro loss	Tex-245-F	✓	✓	2
4. Production Testing				
Control charts	Tex-233-F	✓	✓	1A
Mixture sampling	Tex-222-F	✓	✓	1A
Gradation & asphalt binder content ²	Tex-236-F	✓	✓	1A
Moisture content	Tex-212-F	✓	✓	1A
Micro-Deval abrasion	Tex-461-A		✓	2
Drain-down	Tex-235-F	✓	✓	1A
Boil test	Tex-530-C	✓	✓	1A
Abson recovery	Tex-211-F		✓	TxDOT
5. Placement Testing				
Control charts	Tex-233-F	✓	✓	1A
Ride quality measurement	Tex-1001-S	✓	✓	Note ³
Thermal profile	Tex-244-F	✓	✓	1B
Permeability	Tex-246-F	✓	✓	1B

- Level 1A, 1B, and 2 are certification levels provided by the Hot Mix Asphalt Center certification program.
- Refer to Section 348.4.5., "Production Operations," for exceptions to using an ignition oven.
- Profiler and operator are required to be certified at the Texas A&M Transportation Institute facility when Surface Test Type B is specified.

4.2.

Reporting and Responsibilities. Use Department-provided templates to record and calculate all test data, including mixture design, production and placement tests, control charts, and thermal profiles. Obtain the current version of the templates at <http://www.txdot.gov/inside-txdot/forms-publications/consultants-contractors/forms/site-manager.html> or from the Engineer. The Engineer and the Contractor will provide any available test results to the other party when requested. The Engineer and the Contractor will immediately report to the other party any test result that requires suspension of production or placement or that fails to meet the specification requirements. Record and electronically submit all test results and pertinent information on Department-provided templates.

Subsequent sublots placed after test results are available to the Contractor, which require suspension of operations, may be considered unauthorized work. Unauthorized work will be accepted or rejected at the discretion of the Engineer in accordance with Article 5.3., "Conformity with Plans, Specifications, and Special Provisions."

Use the procedures described in Tex-233-F, when directed, to plot the results of all production and placement testing. Update the control charts as soon as test results for each sublot become available. Make the control charts readily accessible at the field laboratory. The Engineer may suspend production for failure to update control charts.

- 4.3. **Quality Control Plan (QCP).** Develop and follow the QCP in detail. Obtain approval for changes to the QCP made during the project. The Engineer may suspend operations if the Contractor fails to comply with the QCP.

Submit a written QCP before the mandatory pre-paving meeting, when directed. Receive approval of the QCP before beginning production. Include the following items in the QCP:

- 4.3.1. **Project Personnel.** For project personnel, include:
- a list of individuals responsible for QC with authority to take corrective action;
 - current contact information for each individual listed; and
 - current copies of certification documents for individuals performing specified QC functions.
- 4.3.2. **Material Delivery and Storage.** For material delivery and storage, include:
- the sequence of material processing, delivery, and minimum quantities to assure continuous plant operations;
 - aggregate stockpiling procedures to avoid contamination and segregation;
 - frequency, type, and timing of aggregate stockpile testing to assure conformance of material requirements before mixture production; and
 - procedure for monitoring the quality and variability of asphalt binder.
- 4.3.3. **Production.** For production, include:
- loader operation procedures to avoid contamination in cold bins;
 - procedures for calibrating and controlling cold feeds;
 - procedures to eliminate debris or oversized material;
 - procedures for adding and verifying rates of each applicable mixture component (e.g., aggregate, asphalt binder, RAP, RAS, lime, liquid antistriper, WMA, fibers);
 - procedures for reporting job control test results; and
 - procedures to avoid segregation and drain-down in the silo.
- 4.3.4. **Loading and Transporting.** For loading and transporting, include:
- type and application method for release agents; and
 - truck loading procedures to avoid segregation.
- 4.3.5. **Placement and Compaction.** For placement and compaction, include:
- proposed agenda for mandatory pre-paving meeting, including date and location;
 - proposed paving plan (e.g., paving widths, joint offsets, and lift thicknesses);
 - type and application method for release agents in the paver and on rollers, shovels, lutes, and other utensils;
 - procedures for the transfer of mixture into the paver while avoiding segregation and preventing material spillage;
 - process to balance production, delivery, paving, and compaction to achieve continuous placement operations and good ride quality;

- paver operations (e.g., operation of wings, height of mixture in auger chamber) to avoid physical and thermal segregation and other surface irregularities; and
- procedures to construct quality longitudinal and transverse joints.

4.4. Mixture Design.

- 4.4.1. **Design Requirements.** Use the design procedure provided in Tex-204-F, unless otherwise shown on the plans. Design the mixture to meet the requirements listed in Tables 7 and 8. Use a Superpave Gyratory Compactor (SGC) at 50 gyrations as the design number of gyrations (Ndesign).

The Engineer will provide the mixture design when shown on the plans. The Contractor may submit a new mixture design at any time during the project. The Engineer will verify and approve all mixture designs (JMF1) before the Contractor can begin production.

Provide the Engineer with a mixture design report using the Department-provided template. Include the following items in the report:

- the combined aggregate gradation, source, specific gravity, and percent of each material used;
- asphalt binder content and aggregate gradation of RAP and RAS stockpiles;
- the membrane application rate based on design volumetrics;
- results of all applicable tests;
- the mixing and molding temperatures;
- the signature of the Level 2 person or persons that performed the design;
- the date the mixture design was performed; and
- a unique identification number for the mixture design.

Table 7
Master Gradation Limits (% Passing by Weight or Volume)
and Laboratory Mixture Design Properties

Sieve Size	Permeable Friction Course		Thin Bonded Wearing Course		
	Fine (PFC-F)	Coarse (PFC-C)	Type A	Type B	Type C
3/4"	–	100.0 ¹	–	–	100 ¹
1/2"	100.0 ¹	80.0–100.0	–	100 ¹	75–100
3/8"	95.0–100.0	35.0–60.0	100 ¹	75–100	55–80
#4	20.0–55.0	1.0–20.0	35–55	22–36	22–36
#8	1.0–10.0	1.0–10.0	19–30	19–30	19–30
#16	–	–	14–25	14–24	14–24
#50	–	–	7–14	7–14	7–14
#200	1.0–4.0	1.0–4.0	4–6	4–6	4–6

1. Defined as maximum sieve size. No tolerance allowed.

Table 8
Laboratory Mixture Properties for Permeable Friction Course

Mixture Properties	Test Procedure	PG 76 Mixtures		A-R Mixtures	Thin Bonded Wearing Course		
		Fine (PFC-F)	Coarse (PFC-C)	Coarse (PFCR-C)	Type A	Type B	Type C
Asphalt binder content, %	–	6.0–7.0	6.0–7.0	7.0–9.0	5.0–5.8	4.8–5.6	4.8–5.6
Film thickness, microns	–	–	–	–	9.0 Min	9.0 Min	9.0 Min
Design gyrations (Ndesign)	Tex-241-F	50	50	50	50	50	50
Laboratory-molded density, %	Tex-207-F	78.0 Max	82.0 Max	82.0 Max	92.0 Max	92.0 Max	92.0 Max
Hamburg Wheel test, ¹ passes at 12.5 mm rut depth	Tex-242-F	10,000 Min	–	–	–	–	–
Overlay tester, ¹ number of cycles	Tex-248-F	200 Min	–	–	–	–	–
Drain-down, %	Tex-235-F	0.10 Max	0.10 Max	0.10 Max	0.10 Max	0.10 Max	0.10 Max
Fiber content, % by wt. of total PG 76 mixture	Calculated	0.20 ² -0.50	0.20 ² -0.50	–	–	–	–
Lime content, % by wt. of total aggregate	Calculated	1.0 ³	1.0 ³	1.0 ³	–	–	–
CRM content, % by wt. of A-R binder	Calculated	–	–	15.0 Min	–	–	–
Boil test ⁴	Tex-530-C	–	–	–	–	–	–
Cantabro loss, %	Tex-245-F	20.0 Max	20.0 Max	20.0 Max	20.0 Max	20.0 Max	20.0 Max

1. Mold test specimens to Ndesign at the optimum asphalt binder content (JMF1).
2. When at least 3% RAS is used in the mixture, the Contractor may reduce the amount of fibers to no less than 0.10% provided the mixture meets the drain-down requirement.
3. Unless otherwise shown on the plans or waived by the Engineer based on Hamburg Wheel results.
4. Used to establish baseline for comparison to production results. May be waived when approved.

4.4.2. **Job-Mix Formula Approval.** The job-mix formula (JMF) is the combined aggregate gradation, Ndesign level, and target asphalt percentage used to establish target values for hot-mix production. JMF1 is the original laboratory mixture design used to produce the trial batch. When WMA is used, JMF1 may be designed and submitted to the Engineer without including the WMA additive. When WMA is used, document the additive or process used and recommended rate on the JMF1 submittal. The Engineer and the Contractor will verify JMF1 based on plant-produced mixture from the trial batch unless otherwise approved. The Engineer may accept an existing mixture design previously used on a Department project and may waive the trial batch to verify JMF1. The Department may require the Contractor to reimburse the Department for verification tests if more than 2 trial batches per design are required.

4.4.2.1. **Contractor's Responsibilities.**

4.4.2.1.1. **Superpave Gyrotory Compactor.** Furnish an SGC calibrated in accordance with Tex-241-F for molding production samples. Locate the SGC at the Engineer's field laboratory and make the SGC available to the Engineer for use in molding production samples.

4.4.2.1.2. **Gyrotory Compactor Correlation Factors.** Use Tex-206-F, Part II, to perform a gyrotory compactor correlation when the Engineer uses a different SGC. Apply the correlation factor to all subsequent production test results.

4.4.2.1.3. **Hamburg and Overlay Testing.** Use an approved laboratory from the Department's MPL to perform the Hamburg Wheel test, and provide results with the mixture design, or provide 10,000 g of the laboratory mixture and request that the Department perform the Hamburg Wheel test.

Provide 25,000 g of the laboratory mixture and request that the Department perform the Overlay test.

The Engineer will be allowed 10 working days to provide the Contractor with Hamburg Wheel and Overlay test results on the laboratory mixture design.

4.4.2.1.4. **Submitting JMF1.** Furnish a mix design report (JMF1) including Hamburg and Overlay results. Provide representative samples of all component materials and request approval to produce the trial batch.

- 4.4.2.1.5. **Supplying Aggregates.** Provide approximately 40 lb. of each aggregate stockpile unless otherwise directed.
- 4.4.2.1.6. **Supplying Asphalt.** Provide at least 1 gal. of the asphalt material and sufficient quantities of any additives proposed for use.
- 4.4.2.1.7. **Ignition Oven Correction Factors.** Determine the aggregate and asphalt correction factors from the ignition oven in accordance with Tex-236-F. Note that the asphalt content correction factor takes into account the percent fibers in the mixture so that the fibers are excluded from the binder content determination. Provide the Engineer with split samples of the mixtures before the trial batch production, including all additives (except water), and blank samples used to determine the correction factors for the ignition oven used for quality assurance testing during production. Correction factors established from a previously approved mixture design may be used for the current mixture design if the mixture design and ignition oven are the same as previously used unless otherwise directed.
- 4.4.2.1.8. **Boil Test.** Perform the test and retain the tested sample from Tex-530-C until completion of the project or as directed. Use this sample for comparison purposes during production. The Engineer may waive the requirement for the boil test. Add lime or liquid antistripping agent as directed if signs of stripping exist.
- 4.4.2.1.9. **Trial Batch Production.** Provide a plant-produced trial batch upon receiving conditional approval of JMF1 and authorization to produce a trial batch, including the WMA additive or process, if applicable, for verification testing of JMF1 and development of JMF2. Produce a trial batch mixture that meets the requirements in Table 5 and Table 9. The Engineer may accept test results from recent production of the same mixture instead of a new trial batch.
- 4.4.2.1.10. **Trial Batch Production Equipment.** Use only equipment and materials proposed for use on the project to produce the trial batch. Provide documentation to verify the calibration or accuracy of the asphalt mass flow meter to measure the binder content. Verify that asphalt mass flow meter meets the requirements of 0.4 % accuracy, when required, in accordance with Item 520, "Weighing and Measuring Equipment." The Engineer may require that the accuracy of the mass flow meter be verified based on quantities used.
- 4.4.2.1.11. **Trial Batch Quantity.** Produce enough quantity of the trial batch to ensure that the mixture meets the specification requirements.
- 4.4.2.1.12. **Number of Trial Batches.** Produce trial batches as necessary to obtain a mixture that meets the specification requirements.
- 4.4.2.1.13. **Trial Batch Sampling.** Obtain a representative sample of the trial batch and split it into 3 equal portions in accordance with Tex-222-F. Label these portions as "Contractor," "Engineer," and "Referee." Deliver samples to the appropriate laboratory as directed.
- 4.4.2.1.14. **Trial Batch Testing.** Test the trial batch to ensure the mixture produced using the proposed JMF1 meets the mixture requirements in Table 8. Provide the Engineer with a copy of the trial batch test results.
- 4.4.2.1.15. **Development of JMF2.** Evaluate the trial batch test results, determine the target mixture proportions, and submit as JMF2 after the Engineer grants full approval of JMF1 based on results from the trial batch. Verify that JMF2 meets the mixture requirements in Table 8.
- 4.4.2.1.16. **Mixture Production.** After receiving approval for JMF2, use JMF2 to produce Lot 1.
- 4.4.2.1.17. **Development of JMF3.** Evaluate the test results from Lot 1, determine the optimum mixture proportions, and submit as JMF3 for use in Lot 2.
- 4.4.2.1.18. **JMF Adjustments.** If JMF adjustments are necessary to achieve the specified requirements, make the adjustments before beginning a new lot. The adjusted JMF must:
- be provided to the Engineer in writing before the start of a new lot;
 - be numbered in sequence to the previous JMF;

- meet the mixture requirements in Table 8;
- meet the master gradation and binder content limits shown in Table 7; and
- be within the operational tolerances of JMF2 listed in Table 9.

4.4.2.1.19. **Requesting Referee Testing.** Use referee testing, if needed, in accordance with Section 348.4.9.1., “Referee Testing,” to resolve testing differences with the Engineer.

Table 9
Testing Frequency and Mixture Production Tolerances

Test Description	Test Method	Minimum Contractor Testing Frequency	Minimum Engineer Testing Frequency	Operational Tolerance from Current JMF
Individual % retained for sieve sized larger than #200	Tex-200-F	1 per subplot	1 per 12 sublots	±5.0 ¹
% passing the #200 sieve				±2.0 ¹
Laboratory-molded density, %	Tex-207-F, Part VIII	1 per subplot	1 per lot	Table 8
Asphalt binder content, %	Tex-236-F ²	1 per subplot	1 per lot ³	±0.3 ⁴
Drain-down, %	Tex-235-F	1 per subplot	1 per 12 sublots	Table 8
Boil test ⁵	Tex-530-C	1 per project	1 per project	N/A
Membrane application rate	Tex-247-F	1 per lot	1 per 4 lots	+/-0.02
Cantabro loss, %	Tex-245-F	1 per project (sample only)	1 per project	Table 8
Asphalt binder sampling	Tex-500-C	1 per lot (sample only)	1 per project	N/A
Emulsion membrane sampling and testing	Tex-500-C, Part III	1 per lot (sample only)	1 per project	N/A
Thermal profile	Tex-244-F	1 per subplot	Optional	N/A

1. Only applies to mixture produced for Lot 1 and higher. Aggregate gradation is not allowed to be outside the limits shown in Table 7.
2. Ensure the binder content determination excludes fibers. Add the recycled binder content to the flow meter readout when the asphalt mass flow meter is used to determine binder content.
3. May be obtained from asphalt mass flow meter readouts.
4. Binder content is not allowed to be outside the limits shown in Table 7.
5. The Engineer may reduce or waive the sampling and testing requirements based on a satisfactory test history.

4.4.2.2. **Engineer’s Responsibilities.**

4.4.2.2.1. **Superpave Gyratory Compactor.** The Engineer will use a Department SGC calibrated in accordance with Tex-241-F to mold samples for laboratory mixture design verification. For molding trial batch and production specimens, the Engineer will use the Contractor-provided SGC at the field laboratory or provide and use a Department SGC at an alternate location. The Engineer will make the Contractor-provided SGC in the Department field laboratory available to the Contractor for molding verification samples.

4.4.2.2.2. **Hamburg Wheel and Overlay Testing.** At the Contractor’s request, the Department will perform the Hamburg Wheel test on the laboratory mixture in accordance with Tex-242-F to verify compliance with the Hamburg Wheel test requirement in Table 8. The Department will perform the Overlay test in accordance with Tex-248-F to verify compliance with the Overlay test requirements in Table 8. The Engineer will be allowed 10 working days to provide the Contractor with Hamburg Wheel and Overlay test results on the laboratory mixture design.

4.4.2.2.3. **Conditional Approval of JMF1 and Authorizing Trial Batch.** The Engineer will review the Contractor’s mix design report and verify specification conformance of the mixture and component materials. The Engineer will grant conditional approval of JMF1 within 2 working days of receiving the complete mixture design report (JMF1) and all required materials.

The Engineer will determine the Micro-Deval abrasion loss in accordance with Section 348.2.1.1.2., “Micro-Deval Abrasion,” unless waived. If the Engineer’s test results are pending after 2 working days, conditional approval of JMF1 will still be granted within 2 working days of receiving JMF1. When the Engineer’s test results become available, they will be used for specification compliance.

Produce a trial batch after the Engineer grants conditional approval of JMF1.

4.4.2.2.4. **Ignition Oven Correction Factors.** The Engineer will use the split samples provided by the Contractor to determine the aggregate and asphalt correction factors for the ignition oven used for quality assurance testing during production in accordance with Tex-236-F. The Engineer will verify that the asphalt content correction factor takes into account the percent fibers in the mixture so that the fibers are excluded from the binder content determination.

4.4.2.2.5. **Testing the Trial Batch.** The Engineer will sample and test the trial batch within 1 full working day to ensure that the mixture meets the requirements in Table 8.

The Engineer will have the option to perform the following tests on the trial batch:

- Tex-235-F, to verify that drain-down meets the requirements shown in Table 8;
- Tex-530-C, to retain and use for comparison purposes during production; and
- Tex-245-F, to verify the Cantabro loss meets the requirement shown in Table 8.

4.4.2.2.6. **Full Approval of JMF1.** The Engineer will grant full approval of JMF1 and authorize the Contractor to proceed with developing JMF2 if the Engineer's results for the trial batch meet the requirements in Table 9.

The Engineer will notify the Contractor that an additional trial batch is required if the trial batch does not meet these requirements.

4.4.2.2.7. **Approval of JMF2.** The Engineer will approve JMF2 within one working day if the mixture meets the requirements in Table 5 as well as the master grading limits and binder content shown in Tables 7 and 8.

4.4.2.2.8. **Approval of Lot 1 Production.** The Engineer will authorize the Contractor to proceed with Lot 1 production (using JMF2).

4.4.2.2.9. **Approval of JMF3 and Subsequent JMF Changes.** JMF3 and subsequent JMF changes are approved if they meet the mixture requirements shown in Table 8, the master grading and binder content limits shown in Table 7, and are within the operational tolerances of JMF2 shown in Table 9.

4.4.2.2.10. **Binder Content Adjustments.** For JMF2 and above, the Engineer may require the Contractor to adjust the target binder content by no more than 0.3% from the current JMF.

4.5. **Production Operations.** Perform a new trial batch when the plant or plant location is changed. Perform QC at the frequency and within the tolerances listed in Table 9. Take corrective action and receive approval to proceed after any production suspension for noncompliance to the specification. Submit a new mix design and perform a new trial batch when the asphalt binder content of:

- any RAP stockpile used in the mix is more than 0.5% higher than the value shown on the mixture design report; or
- RAS stockpile used in the mix is more than 2.0% higher than the value shown on the mixture design report.

At any time during production, the Engineer may require the Contractor to verify the following based on quantities used:

- lime content (within $\pm 0.1\%$ of JMF), when PG binder is specified;
- fiber content (within $\pm 0.03\%$ of JMF), when PG binder is specified; and
- CRM content (within $\pm 1.5\%$ of JMF), when A-R binder is specified.

Maintain the in-line measuring device, when A-R binder is specified, to verify the A-R binder viscosity between 2,500 and 4,000 centipoise at 350°F unless otherwise approved. Record A-R binder viscosity at least once per hour and provide a daily summary unless otherwise directed.

The Engineer may allow alternate methods for determining the asphalt content and aggregate gradation if the aggregate mineralogy is such that Tex-236-F does not yield reliable results. The Engineer will require the Contractor to provide evidence that results from Tex-236-F are not reliable before permitting an alternate method unless otherwise allowed. Use the applicable test procedure as directed if an alternate test method is allowed.

4.5.1. **Storage and Heating of Materials.** Do not heat the asphalt binder above the temperatures specified in Item 300, "Asphalts, Oils, and Emulsions," or outside the manufacturer's recommended values. Provide the Engineer with daily records of asphalt binder and hot-mix asphalt discharge temperatures (in legible and discernible increments) in accordance with Item 320, "Equipment for Asphalt Concrete Pavement," unless otherwise directed. Do not store mixture for a period long enough to affect the quality of the mixture, nor in any case longer than 12 hr. unless otherwise approved.

4.5.2. **Mixing and Discharge of Materials.** Notify the Engineer of the target discharge temperature and produce the mixture within 25°F of the target. Monitor the temperature of the material in the truck before shipping to ensure that it does not exceed 350°F (or 275°F for WMA) and is not lower than 215°F. The Department will not pay for or allow placement of any mixture produced above 350°F.

Produce WMA within the target discharge temperature range of 215°F and 275°F when WMA is required. Take corrective action any time the discharge temperature of the WMA exceeds the target discharge range. The Engineer may suspend production operations if the Contractor's corrective action is not successful at controlling the production temperature within the target discharge range. Note that when WMA is produced, it may be necessary to adjust burners to ensure complete combustion such that no burner fuel residue remains in the mixture.

Control the mixing time and temperature so that substantially all moisture is removed from the mixture before discharging from the plant. Determine the moisture content, if requested, by oven-drying in accordance with Tex-212-F, Part II, and verify that the mixture contains no more than 0.2% of moisture by weight. Obtain the sample immediately after discharging the mixture into the truck, and perform the test promptly.

4.6. **Hauling Operations.** Clean all truck beds before use to ensure that mixture is not contaminated. Use a release agent shown on the Department's MPL to coat the inside bed of the truck when necessary.

Use equipment for hauling as defined in Section 348.4.7.3.2., "Hauling Equipment." Use other hauling equipment only when allowed.

4.7. **Placement Operations.** Collect haul tickets from each load of mixture delivered to the project and provide the Department's copy to the Engineer approximately every hour, or as directed. Use a hand-held thermal camera or infrared thermometer, when a thermal imaging system is not used, to measure and record the internal temperature of the mixture as discharged from the truck or Material Transfer Device (MTD) before or as the mix enters the paver and an approximate station number or GPS coordinates on each ticket. Calculate the daily yield and cumulative yield for the specified lift and provide to the Engineer at the end of paving operations for each day unless otherwise directed. The Engineer may suspend production if the Contractor fails to produce and provide haul tickets and yield calculations by the end of paving operations for each day.

Prepare the surface by removing raised pavement markers and objectionable material such as moisture, dirt, sand, leaves, and other loose impediments from the surface before placing mixture. Remove vegetation from pavement edges. Place the mixture to meet the typical section requirements and produce a smooth, finished surface with a uniform appearance and texture. Offset longitudinal joints of successive courses of hot-mix by at least 6 in. Place mixture so that longitudinal joints on the surface course coincide with lane lines, or as directed. Ensure that all finished surfaces will drain properly.

4.7.1. **Weather Conditions.**

4.7.1.1. **When Using a Thermal Imaging System.** The Contractor may pave any time the roadway is dry and the roadway surface temperature is at least 60°F; however, the Engineer may restrict the Contractor from paving if the ambient temperature is likely to drop below 32°F within 12 hr. of paving. Provide output data from the

thermal imaging system to demonstrate to the Engineer that no recurring severe thermal segregation exists in accordance with Section 348.4.7.3.1.2., "Thermal Imaging System."

4.7.1.2. **When Not Using a Thermal Imaging System.** Place mixture when the roadway surface temperature is at or above 70°F unless otherwise approved or as shown on the plans. Measure the roadway surface temperature with a hand-held thermal camera or infrared thermometer. The Engineer may allow mixture placement to begin before the roadway surface reaches the required temperature if conditions are such that the roadway surface will reach the required temperature within 2 hr. of beginning placement operations. Place mixtures only when weather conditions and moisture conditions of the roadway surface are suitable as determined by the Engineer. The Engineer may restrict the Contractor from paving if the ambient temperature is likely to drop below 32°F within 12 hr. of paving.

4.7.2. **Application of Membrane.** Apply the membrane at the rates shown in Table 9 unless otherwise directed. Spray the membrane using a metered mechanical pressure spray bar at a temperature of 140°F to 180°F. Monitor the membrane application rate and make adjustments to the rate when needed or when directed. Verify that the spray bar, if required, is capable of applying the membrane at a uniform rate across the entire paving width as directed. Do not let the wheels or other parts of the paving machine contact the freshly applied membrane.

Table 10
Membrane Application Rate Limits, (Gal. per Square Yard)

Mix Type	Lift Thickness	Membrane Rate
Permeable Friction Course	1-1/2 in.	0.30–0.33
	1-1/4 in.	0.27–0.30
	1 in.	0.25–0.28
	3/4 in.	0.22–0.25
Thin Bonded Wearing Course	3/4 in.	0.17–0.27
	5/8 in.	0.16–0.24
	1/2 in.	0.14–0.20

4.7.3. **Lay-Down Operations.**

4.7.3.1. **Thermal Profile.** Use a hand-held thermal camera or a thermal imaging system to obtain a continuous thermal profile in accordance with Tex-244-F. Thermal profiles are not applicable in areas described in Section 348.4.9.5., "Miscellaneous Areas."

4.7.3.1.1. **Thermal Segregation.**

4.7.3.1.1.1. **Moderate.** Any areas that have a temperature differential greater than 25°F, but not exceeding 50°F, are deemed as having moderate thermal segregation.

4.7.3.1.1.2. **Severe.** Any areas that have a temperature differential greater than 50°F are deemed as having severe thermal segregation.

4.7.3.1.2. **Thermal Imaging System.** Review the output results when a thermal imaging system is used, and provide the automated report described in Tex-244-F to the Engineer daily unless otherwise directed. Modify the paving process as necessary to eliminate any recurring (moderate or severe) thermal segregation identified by the thermal imaging system. The Engineer may suspend paving operations if the Contractor cannot successfully modify the paving process to eliminate recurring severe thermal segregation. Provide the Engineer with electronic copies of all daily data files that can be used with the thermal imaging system software to generate temperature profile plots upon completion of the project or as requested by the Engineer.

4.7.3.1.3. **Thermal Camera.** Take immediate corrective action to eliminate recurring moderate thermal segregation when a hand-held thermal camera is used. Provide the Engineer with the thermal profile of every subplot within one working day of the completion of each lot. Report the results of each thermal profile in accordance with Section 348.4.2., "Reporting and Responsibilities." The Engineer will use a hand-held thermal camera to obtain a thermal profile at least once per project. Suspend operations and take immediate corrective action to

eliminate severe thermal segregation unless otherwise directed. Resume operations when the Engineer determines that subsequent production will meet the requirements of this Section.

- 4.7.3.2. **Hauling Equipment.** Use live bottom or end dump trucks to haul and transfer mixture; however, with exception of paving miscellaneous areas, end dump trucks are only allowed when used in conjunction with an MTD with remixing capability or when a thermal imaging system is used unless otherwise allowed.
- 4.7.3.3. **Screed Heaters.** Turn off screed heaters to prevent overheating of the mat if the paver stops for more than 5 min. The Engineer may evaluate the suspect area in accordance with Section 348.4.9.6., "Recovered Asphalt Dynamic Shear Rheometer (DSR)," if the screed heater remains on for more than 5 min. while the paver is stopped.
- 4.8. **Compaction.** Roll the freshly placed PFC with a steel-wheeled roller, operated in static mode, to seat the mixture without excessive breakage of the aggregate and to provide a smooth surface and uniform texture. Do not use pneumatic rollers. Moisten the roller drums thoroughly with a soap and water solution to prevent adhesion. Use only water or an approved release agent on rollers, tamps, and other compaction equipment unless otherwise directed.

The Engineer may use or require the Contractor to use Tex-246-F to test and verify that the compacted mixture has adequate permeability. Adjust the mixture design or construction methods if the compacted mixture does not exhibit adequate permeability.

Complete all compaction operations before the pavement temperature drops below 160°F unless otherwise allowed. The Engineer may allow compaction with a light finish roller operated in static mode for pavement temperatures below 160°F.

Allow the compacted pavement to cool to 160°F or lower before opening to traffic unless otherwise directed. Sprinkle the finished mat with water or limewater, when directed, to expedite opening the roadway to traffic.

- 4.9. **Acceptance Plan.** Sample and test the hot-mix on a lot and subplot basis. A production lot consists of 4 equal sublots. Lot 1 will be 2,000 tons. The Engineer will select subsequent lot sizes based on the anticipated daily production. The lot size will be between 2,000 and 4,000 tons. The Engineer may change the lot size before the Contractor begins any lot.
- 4.9.1. **Referee Testing.** The Construction Division is the referee laboratory. The Contractor may request referee testing if the differences between Contractor and Engineer test results exceed the operational tolerances shown in Table 9 and the differences cannot be resolved. The Contractor may also request referee testing if the Engineer's test results require suspension of production and the Contractor's test results are within specification limits. Make the request within 5 working days after receiving test results and cores from the Engineer. Referee tests will be performed only on the subplot in question and only for the particular tests in question. Allow 10 working days from the time the referee laboratory receives the samples for test results to be reported. The Department may require the Contractor to reimburse the Department for referee tests if more than 3 referee tests per project are required and the Engineer's test results are closer to the referee test results than the Contractor's test results.
- 4.9.2. **Asphalt Binder Sampling.** Obtain a 1-qt. (1 gal. for A-R binder) sample of the asphalt binder for each lot of mixture produced. Obtain the sample at approximately the same time the mixture random sample is obtained. Sample from a port located immediately upstream from the mixing drum or pug mill in accordance with Tex-500-C, Part II. Label the can with the corresponding lot and subplot numbers and deliver the sample to the Engineer. The Engineer may also obtain independent samples. If obtaining an independent asphalt binder sample, the Engineer will split a sample of the asphalt binder with the Contractor. The Engineer will test at least one asphalt binder sample per project to verify compliance with Item 300, "Asphalts, Oils, and Emulsions."
- 4.9.3. **Membrane.** Obtain a 1-qt. sample of the membrane material for each subplot. Obtain the sample from the spray bar on the paver. Label the can with the corresponding lot number, and deliver the sample to the Engineer. The Engineer may also obtain independent samples. If the Engineer chooses to obtain an

independent sample, the Engineer will split a sample of the membrane with the Contractor. The Engineer will test at least 1 membrane sample per project to verify specification compliance.

- 4.9.4. **Operational Tolerances.** Control the production process within the operational tolerances listed in Table 9. Suspend production and placement operations when production or placement test results exceed the tolerances listed in Table 9 unless otherwise allowed. The Engineer will allow suspended production to resume when test results or other information indicates the next mixture produced will be within the operational tolerances.
- 4.9.5. **Miscellaneous Areas.** Miscellaneous areas include areas that typically involve significant handwork or discontinuous paving operations such as driveways, mailbox turnouts, crossovers, gores, spot level-up areas, and other similar areas. The specified layer thickness is based on the rate of 90 lb./sq. yd. for each inch of pavement unless another rate is shown on the plans. Miscellaneous areas are not subject to thermal profiles testing.
- 4.9.6. **Recovered Asphalt Dynamic Shear Rheometer (DSR).** The Engineer may take production samples or cores from suspect areas of the project to determine recovered asphalt properties. Asphalt binders with an aging ratio greater than 3.5 do not meet the requirements for recovered asphalt properties and may be deemed defective when tested and evaluated by the Construction Division. The aging ratio is the DSR value of the extracted binder divided by the DSR value of the original unaged binder. Obtain DSR values in accordance with AASHTO T 315 at the specified high temperature performance grade of the asphalt. The Engineer may require removal and replacement of the defective material at the Contractor's expense. The asphalt binder will be recovered for testing from production samples or cores in accordance with Tex-211-F.
- 4.9.7. **Irregularities.** Identify and correct irregularities including segregation, rutting, raveling, flushing, fat spots, mat slippage, irregular color, irregular texture, roller marks, tears, gouges, streaks, uncoated aggregate particles, or broken aggregate particles. The Engineer may also identify irregularities, and in such cases, the Engineer will promptly notify the Contractor. If the Engineer determines that the irregularity will adversely affect pavement performance, the Engineer may require the Contractor to remove and replace (at the Contractor's expense) areas of the pavement that contain irregularities and areas where the mixture does not bond to the existing pavement. If irregularities are detected, the Engineer may require the Contractor to immediately suspend operations or may allow the Contractor to continue operations for no more than one day while the Contractor is taking appropriate corrective action.
- 4.9.8. **Ride Quality.** Measure ride quality in accordance with Item 585, "Ride Quality for Pavement Surfaces," unless otherwise shown on the plans.

5. MEASUREMENT

Thin Bonded Friction Courses will be measured by the ton of composite membrane, asphalt, aggregate, and additives. The weights of asphalt and aggregate will be calculated based on the measured weight of the target percentage of asphalt and aggregate. Measure on scales in accordance with Item 520, "Weighing and Measuring Equipment."

- 5.1. **Membrane.** Unless otherwise noted on the plans, membrane material will be measured by volume. Membrane material will be measured at the applied temperature by strapping the tank before and after road application and determining the net volume in gallons from the distributor's calibrated strap stick. The quantity to be measured for payment will be the number of gallons used, as directed, in the accepted membrane.
- 5.2. **Asphalt.** The asphalt weight in tons will be determined from the total weight of mixture. Measured asphalt percentage will be obtained using Tex-236-F or asphalt mass flow meter readings for PG 76 mixtures, as determined by the Engineer. Measured asphalt percentage will be obtained using asphalt mass flow meter readings for A-R mixtures. Provide the Engineer with a daily summary of the asphalt mass flow meter readings for A-R mixtures unless otherwise directed. Add the recycled binder content to the flow meter readings when calculating asphalt quantities.

- 5.2.1. **Target Percentage.** The JMF target asphalt percentage will be used to calculate the weight of asphalt binder unless the measured asphalt binder percentage is more than 0.3 percentage points below the JMF target asphalt percentage or less than the minimum percentage specified in Table 8. Volumetric meter readings will be adjusted to 140°F and converted to weight.
- 5.2.2. **Measured Percentage.** The averaged measured asphalt percentage from each subplot will be used for payment for that lot's production when the measured percentage for any subplot is more than 0.3 percentage points below the JMF target asphalt percentage or less than the minimum percentage specified in Table 8.
- 5.3. **Aggregate.** The aggregate weight in tons will be determined from the total weight of PFC less the weight of the asphalt.

6. PAYMENT

The work performed and materials furnished in accordance with this Item and measured as provided under Article 348.5., "Measurement," will be paid for at the unit bid price for Thin Bonded Friction Courses membrane, asphalt of the binder specified and for aggregate of the Surface Aggregate Classification specified. These prices are full compensation for surface preparation, materials, placement, equipment, labor, tools, and incidentals.

Trial batches will not be paid for unless they are included in pavement work approved by the Department.

Payment adjustment for ride quality will be determined in accordance with Item 585, "Ride Quality for Pavement Surfaces."

Item 350

Microsurfacing



1. DESCRIPTION

Furnish and place a microsurfacing system consisting of a mixture of cationic polymer-modified asphalt emulsion, mineral aggregate, mineral filler, water, and other additives.

2. MATERIALS

Furnish uncontaminated materials of uniform quality that meet the requirements of the plans and specifications. Provide the Engineer with representative samples of all component materials for verification.

Notify the Engineer of all material sources and before changing any material source or formulation. The Engineer will verify that the specification requirements are met when the Contractor makes a source or formulation change, and may require a new laboratory mixture design, trial batch, or both. The Engineer may sample and test project materials at any time during the project to verify specification compliance in accordance with Item 6, "Control of Materials."

2.1. **Cationic Polymer-Modified Asphalt Emulsion.** Provide CSS-1P in accordance with Section 300.2.4., "Emulsified Asphalt."

2.2. **Aggregate.** Furnish crushed aggregate from a single source meeting the requirements of Table 1 and Table 2. Determine aggregate gradations for mixture design and production testing based on the washed sieve analysis given in Tex-200-F, Part II. Aggregate from sources listed in the Department's *Bituminous Rated Source Quality Catalog* (BRSQC) are preapproved for use.

For sources not listed on the Department's BRSQC:

- build an individual stockpile for each material;
- request the Department test the stockpile for specification compliance; and
- once approved, do not add material to the stockpile unless otherwise approved.

Allow 30 calendar days for the Engineer to sample, test, and report results for non-listed sources. Do not combine approved material with unapproved material. Include the amount of mineral filler added to the mix in determining the total minus No. 200 aggregate fraction.

Table 1
Master Gradation Limits
(% Passing by Weight or Volume)

Sieve Size	% Passing
3/8"	100.0
#4	86.0-94.0
#8	45.0-65.0
#16	25.0-46.0
#30	15.0-35.0
#50	10.0-25.0
#100	7.0-18.0
#200	5.0-15.0

Table 2
Aggregate Quality Requirements

Property	Test Method	Requirement
SAC	Tex-499-A (AQMP)	A ¹
Magnesium sulfate soundness, 5 cycles, %, Max	Tex-411-A	25
Crushed face count, ² %, Min	Tex-460-A, Part I	95
Sand equivalent, %, Min	Tex-203-F	70
Acid insoluble, (%), Min	Tex-612-J	55

1. Surface Aggregate Classification of "A" is required unless otherwise shown on the plans.

2. Only applies to crushed gravel.

- 2.3. **Mineral Filler.** Provide a mineral filler that is sufficiently dry, free-flowing, and free of clumps and foreign matter consisting of non-air-entrained cement meeting the requirements of DMS-4600, "Hydraulic Cement," or hydrated lime meeting the requirements of DMS-6350, "Lime and Lime Slurry."
- 2.4. **Water.** Provide water that is potable and free of harmful soluble salts.
- 2.5. **Other Additives.** Use approved additives as recommended by the emulsion manufacturer in the emulsion mix or in any of the component materials when necessary to adjust mix time in the field.
- 2.6. **Tack Coat.** Furnish CSS-1H or SS-1H for tack coat binder in accordance with Item 300, "Asphalts, Oils, and Emulsions." Specialized or preferred tack coat materials may be allowed or required when shown on the plans. Do not dilute emulsified asphalts at the terminal, in the field, or at any other location before use.

3. EQUIPMENT

Maintain equipment in good repair and operating condition.

- 3.1. **Mixing Machine.** Furnish a self-propelled microsurfacing mixing machine with:
- self-loading devices to promote continuous laying operations;
 - enough storage capacity for mixture materials;
 - individual volume or weight controls that will proportion each material to be added to the mix;
 - continuous flow mixing with a revolving multi-blade mixer capable of discharging the mixture on a continuous flow basis;
 - opposite side driving stations;
 - full hydrostatic control of the forward and reverse speed during operation;
 - a water pressure system and nozzle-type spray bar immediately ahead of the spreader box and capable of spraying the roadway for the width of the spreader box;
 - a mechanical-type spreader box equipped with paddles or other devices capable of agitating and spreading the materials throughout the box;
 - a spreader box with devices capable of providing lateral movement or side shift abilities; and
 - a spreader box with a front seal, adjustable rear strike-off, and an adjustable secondary rear strike-off.

Calibrate and properly mark each control device that proportions the individual materials. Equip the aggregate feed with a revolution counter or similar device capable of determining the quantity of aggregate used at all times. Provide a positive-displacement-type emulsion pump with a revolution counter or similar device capable of determining the quantity of emulsion used at all times. Provide an approved mineral filler feeding system capable of uniformly and accurately metering the required material.

- 3.2. **Scales.** Scales used for weighing aggregates and emulsion must meet all requirements of Item 520, "Weighing and Measuring Equipment." The weighing equipment for aggregates may be either a suspended hopper or a belt scale.

- 3.3. **Asphalt Storage and Handling Equipment.** Furnish a thermometer in each tank to indicate the asphalt temperature when continuously storage tanks are used. Keep equipment clean and free of leaks. Keep asphalt materials free from contamination.

4. CONSTRUCTION

Produce, transport, and place microsurfacing as specified in this Item or as shown on the plans. Provide emulsion and aggregate that are compatible so that the mixing process will completely and uniformly coat the aggregate. Ensure that the finished surface has a uniform texture and the microsurface mat is fully adhered to the underlying pavement. The Engineer may perform production tests at any time during the project, as deemed necessary in accordance with Item 5, "Control of the Work." Schedule and participate in a pre-paving meeting with the Engineer on or before the first day of paving unless otherwise directed.

- 4.1. **Mixture Design.** Provide a mixture design meeting the proportions shown in Table 3 and the requirements shown in Table 4. Provide the Engineer with representative samples of all component materials for verification of the mix design, unless otherwise directed. The Construction Division will verify the mixture design to ensure it meets the minimum requirements for wet track abrasion wear value listed in Table 4. Provide the Engineer with approximately 40 lbs. of each aggregate stockpile, at least 1 gal. of asphalt emulsion, at least 1 gal. of mineral filler, and sufficient quantities of any additives proposed for use.

The Engineer may accept an existing mixture design previously used on a Department project but the mixture design may be subjected to annual verification using laboratory-produced mixes before starting the paving season. Production may begin at the Contractor's risk without receiving the results from the Department's verification if approved by the Engineer.

Table 3
Mixture Design Proportions

Material	Proportion
Residual asphalt	6.0% to 9.0% by wt. of dry aggregate
Mineral filler (hydraulic cement or hydrated lime)	0.5% to 3.0% by wt. of dry aggregate
Field control additive	As required to provide control of break and cure
Water	As required to produce proper mixture consistency

Table 4
Mixture Design Requirements

Property	Test Method	Requirements
Wet track abrasion, g/sq. ft., Max wear value	Tex-240-F, Part V	75
Gradation (aggregate and mineral filler)	Tex-200-F, Part II (Washed)	Table 1
Mix time, controlled to 120 sec.	Tex-240-F, Part II	Pass
Lateral displacement	ISSA TB-147	5% Max
Specific gravity after 1,000 cycles of 125 lbs.		2.10 Max
Excessive asphalt by LWT	ISSA TB-109	50 g/ft ²
Sand Adhesion		(538 g/m ²) Max

- 4.2. **Reporting, Testing, and Responsibilities.** Use Department-provided templates to record and calculate all test data pertaining to production testing. Obtain the current version of the templates at <http://www.txdot.gov/inside-txdot/forms-publications/consultants-contractors/forms/site-manager.html> or from the Engineer. The Engineer will immediately report to the Contractor any test results that fail to meet the specification requirements.

Note that mix placed after test results are available to the Contractor may be considered unauthorized work if the results require suspension of operations. Unauthorized work will be accepted or rejected at the discretion of the Engineer in accordance with Article 5.3., "Conformity with Plans, Specifications, and Special Provisions."

- 4.3. **Temporary Material Storage.**
- 4.3.1. **Aggregate Storage.** Stockpile materials to prevent segregation or contamination. Remix stockpiles with suitable equipment when necessary to eliminate segregation. Use a scalping screen to remove oversize material while transferring aggregates to the mixing machine.
- 4.3.2. **Mineral Filler Storage.** Store the mineral filler in a manner that will keep it dry and free from contamination.
- 4.3.3. **Asphalt Material Storage.** Keep asphalt materials free from contamination.
- 4.4. **Weather Limitations.** The Contractor may pave any time the roadway has no standing water on the roadway surface, the roadway surface temperature is at least 60°F and the ambient temperature is at least 50°F and rising. Place mixtures only when the Engineer determines the roadway surface weather and moisture conditions are suitable. The Engineer may restrict the Contractor from paving if the ambient temperature is below 60°F and falling. Cease placement 24 hr. before the weather forecast (National Weather Service) predict temperatures below 32°F unless otherwise approved.
- 4.5. **Surface Preparation.** Prepare the surface by removing raised pavement markers and objectionable material such as moisture, dirt, sand, leaves, and other loose impediments from the surface before placing mixture. Provide a water spray immediately ahead of the spreader box when required for existing surface conditions when tack coat is not required. Apply water at a rate that will dampen the entire surface without any free-flowing water ahead of the spreader box.
- 4.6. **Tack Coat.** Apply tack coat uniformly at the rate directed by the Engineer when shown on the plans. The Engineer will set the rate between 0.04 and 0.10 gal. of residual asphalt per square yard of surface area. Apply the tack coat in a uniform manner to avoid streaks and other irregular patterns.
- 4.7. **Material Transfer.** Minimize construction joints by providing continuous loading of material during placement. Remove oversized material before transferring the aggregates to the mixing machine.
- 4.8. **Placing.** Make necessary adjustments so that the mixture will have sufficient working life to allow for proper placement at the predicted ambient temperature and humidity. Spread the mixture uniformly to the lines and grades shown on the plans or as directed by means of a mechanical type spreader box. Shift the spreader box when necessary to maintain proper alignment. Clean the spreader box regularly to prevent build up from occurring and to minimize clumps. Set and maintain the spreader box skids to prevent chatter in the finished mat. Prevent loss of material from the spreader box by maintaining contact between the front seal and the road surface. Adjust the rear seal to provide the desired spread. Adjust the secondary strike-off to provide the desired surface texture. Clean strike-off regularly to prevent build up from occurring.
- 4.9. **Curing.** Protect the finished mat from traffic until the mixture cures and will not be damaged by traffic. Adjust mixture properties according to humidity conditions and ambient temperatures to allow traffic on completed travel lanes within 1 hr. after placement with no damage to the surface. Protect locations subject to sharp turning, stopping, and starting traffic for longer periods when necessary.
- 4.10. **Production Testing.** Control the production process within the operational tolerances listed in Table 5. Provide access to the mixing unit discharge stream for sampling purposes. Suspend production when the Engineer's test results exceed the operational tolerances. The Engineer will allow production to resume when test results or other information indicate the next mixture produced will be within the operational tolerances listed in Table 5.

Table 5
Operational Tolerances

Property	Test Method	Requirements
Asphalt content, % by wt.	Tex-236-F ¹ or asphalt meter readings	Design target $\pm 0.5\%$
Gradation (washed), % passing	Tex-200-F, Part II from stockpile	#8 sieve and larger: ± 5 from design gradation. #16 sieve and smaller: ± 3 from design gradation ²

1. Dried to constant wt. at 230°F $\pm 10^\circ$ F.
2. Material passing #200 sieve including the mineral filler must conform to the limitations of the master gradation shown in Table 1.

The asphalt content may be reduced below the tolerance when lean mixes are necessary for scratch and rut passes but not less than the design minimum shown for the wet track abrasion test when approved.

- 4.11. **Workmanship.** Immediately take corrective action if microsurfacing material is exhibiting evidence of poor workmanship, delayed opening to traffic, or surface irregularities, including excessive scratch marks, drag marks, tears, streaks, raveling, delamination, and segregation. The Engineer may allow placement to continue for no more than one day of production while taking appropriate action. Suspend paving if the problem still exists after one day until the problem is corrected to the satisfaction of the Engineer.
- 4.11.1. **Finished Surface.** Provide a finished surface with a uniform texture free from excessive scratch marks, tears, or other surface irregularities. Marks, tears, or irregularities are considered excessive if:
- more than 1 is at least 1/4 in. wide and at least 10 ft. long in any 100 ft. of machine pull,
 - more than 3 are at least 1/2 in. wide and more than 6 in. long in any 100 ft. of machine pull, or
 - any are 1 in. wide or wider and more than 4 in. in length.
- 4.11.2. **Construction Joints.** Place mixture so that longitudinal joints on the surface course coincide with lane lines, or as directed. Provide longitudinal and transverse joints that are uniform and neat in appearance. Provide construction joints that have limited buildup and no gaps between applications. Joints with buildup will be considered acceptable if:
- no more than 1/2-in. vertical space exists between the pavement surface and a 4-ft. straightedge placed perpendicular to the longitudinal joint and
 - no more than 1/4-in. vertical space exists between the pavement surface and a 4-ft. straightedge placed perpendicular to the transverse joint.
- 4.11.3. **Edges.** Provide an edge along the roadway centerline, lane lines, shoulder, edge of pavement, or curb line that is uniform and neat in appearance. The edge is considered acceptable when:
- it varies no more than ± 3 in. from a 100-ft. straight line on a tangent section and
 - it varies no more than ± 3 in. from a 100-ft. arc on a curved section.
- 4.12. **Miscellaneous Areas.** Use a single-batch-type lay-down machine or other approved method to place materials on ramps or other short sections. Apply tack coat uniformly at the rate directed by the Engineer when shown on the plans or lightly dampen the surface with water before placing the mix when tack coat is not required. Provide 100% coverage that is uniform in appearance and comparable to that produced by the spreader box.
- 4.13. **Ruts.** Fill ruts, utility cuts, and depressions in the existing surface in a separate pass from the final surface when shown on the plans. Fill ruts as follows:
- Fill irregular or shallow ruts less than 1/2 in. deep with a full-width scratch coat pass. Use a rigid primary strike-off plate unless otherwise approved.
 - Fill ruts 1/2 in. deep or deeper independently using a rut-filling spreader box that is at least 5 ft. wide. Crown the spreader box to compensate for traffic compaction.

- Fill ruts deeper than 1-1/2 in. in multiple placements unless otherwise approved.
- Cure each lift 24 hours before placement of the next lift when using multiple placements.

4.14. **Repairs.** Perform full width repairs unless otherwise directed.

5. MEASUREMENT

Microsurfacing will be measured by the ton of the composite microsurfacing mixture, which includes asphalt emulsion, aggregate, and mineral filler.

- 5.1. **Aggregate.** The quantity of aggregate used in the accepted portion of work will be measured by net ticket weight of each individual load of aggregate based on dry weight of aggregate. Weigh the aggregate at the project stockpile site unless otherwise approved. Use either a suspended hopper scale or a belt scale meeting the requirements of Item 520, "Weighing and Measuring Equipment." The calculated weight of mineral filler based on the accepted portion of work will be used for measurement and included in the total aggregate weight.
- 5.2. **Polymer-Modified Asphalt Emulsion.** The quantity of polymer-modified asphalt emulsion in the accepted portion of work will be measured by the ton of material based on the accepted load tickets issued from the manufacturer. At the completion of the project, any unused emulsion will be weighed back and deducted from the accepted asphalt emulsion quantity delivered.

6. PAYMENT

The work performed and materials furnished in accordance with this Item and measured as provided under "Measurement" will be paid for at the unit bid price per ton for "Microsurfacing." This price is full compensation for preparing the existing surface (including removing existing raised pavement markers); furnishing, hauling, preparing, and placing materials; and equipment, labor, tools, and incidentals.

Item 351

Flexible Pavement Structure Repair



1. DESCRIPTION

Repair localized sections of flexible pavement structure including subgrade, base, and surfacing as shown on the plans.

2. MATERIALS

Furnish materials unless otherwise shown on the plans. Provide materials of the type and grade as shown on the plans and in accordance with the following.

- Item 132, "Embankment"
- Item 204, "Sprinkling"
- Item 247, "Flexible Base"
- Item 260, "Lime Treatment (Road-Mixed)"
- Item 263, "Lime Treatment (Plant-Mixed)"
- Item 275, "Cement Treatment (Road-Mixed)"
- Item 276, "Cement Treatment (Plant-Mixed)"
- Item 292, "Asphalt Treatment (Plant-Mixed)"
- Item 310, "Prime Coat"
- Item 316, "Seal Coat"
- Item 330, "Limestone Rock Asphalt Pavement"
- Item 334, "Hot-Mix Cold-Laid Asphalt Concrete Pavement"
- Item 340, "Dense Graded Hot-Mix Asphalt (Small Quantity)"

For asphalt concrete materials, Contractor testing and payment adjustment provisions will be waived unless otherwise shown on the plans.

3. EQUIPMENT

Furnish equipment in accordance with pertinent Items. Use of a motor grader will be permitted for asphalt concrete pavement unless otherwise shown on the plans.

4. WORK METHODS

Repair using one or more of the following operations as shown on the plans. For Contracts with callout work, begin physical repair within 24 hr. of notification unless otherwise shown on the plans. Cut neat vertical faces around the perimeter of the work area when removing pavement structure layers. Removed materials are the property of the Contractor unless otherwise shown on the plans. Dispose of removed material in accordance with federal, state, and local regulations. Provide a smooth line and grade conforming to the adjacent pavement.

- 4.1. **Removing Pavement Structure.** Remove adjacent soil and vegetation if necessary to prevent contamination of the repair area, and place it in a windrow. Do not damage adjacent pavement structure during repair operations. Remove flexible pavement structure layers from work area if subgrade work is required.

- 4.2. **Preparing Subgrade.** Fill holes, ruts, and depressions with approved material. Wet, reshape, and compact the subgrade thoroughly as directed.
- Remove unstable subgrade material to the depth directed and replace with an approved material where subgrade has failed.
- 4.3. **Mixing and Placing Base Material.** Place, spread, and compact material in accordance with the applicable Item to the required or directed depth. Pulverize bituminous material to a maximum dimension of 2-1/2 in. and uniformly mix with existing base to the depth shown on the plans when the material is to remain in pavement structure.
- 4.3.1. **Flexible Base.** Use existing base and add new flexible base as required in accordance with Item 247, "Flexible Base," and details shown on the plans to achieve required section.
- 4.3.2. **Lime-Stabilized Base.** Use existing base, add new flexible base, and stabilize with a minimum lime content of 3% by weight of the total mixture. Construct in accordance with Item 260, "Lime Treatment (Road-Mixed)," or Item 263, "Lime Treatment (Plant-Mixed)," and details shown on the plans to achieve required section.
- 4.3.3. **Cement-Stabilized Base.** Use existing base, add flexible base, and stabilize with a minimum cement content of 4% by weight of the total mixture. Construct in accordance with Item 275, "Cement Treatment (Road-Mixed)," or Item 276, "Cement Treatment (Plant-Mixed)," and details shown on the plans to achieve required section.
- 4.3.4. **Asphalt-Stabilized Base.** Place asphalt-stabilized base in accordance with Item 292, "Asphalt Treatment (Plant-Mixed)," or Item 340, "Dense-Graded Hot-Mix Asphalt (Small Quantity)," and details shown on the plans to achieve required section.
- 4.3.5. **Limestone Rock Asphalt.** Place in accordance with Item 330, "Limestone Rock Asphalt Pavement," and details shown on the plans to achieve required section.
- 4.4. **Curing Base.** Cure in accordance with the appropriate Item unless otherwise directed or approved. Maintain completed base sections until surfacing.
- 4.5. **Surfacing.** Apply surfacing with materials as shown on the plans to the completed base section.
- 4.5.1. **Prime Coat.** Protect the compacted, finished, and cured flexible, lime-stabilized, or cement-stabilized base mixtures with a prime coat of the type and grade shown on the plans. Apply the prime coat at the rate shown on the plans.
- 4.5.2. **Surface Treatments.** Apply surface treatment with the type and grade of asphalt and aggregate as shown on the plans in accordance with Item 316, "Seal Coat."
- 4.5.3. **Asphalt Concrete Pavement.** Apply tack coat of the type and grade and at the rate shown on the plans unless otherwise directed. Construct in accordance with Item 330, "Limestone Rock Asphalt Pavement," Item 334, "Hot-Mix Cold-Laid Asphalt Concrete Pavement," or Item 340, "Dense-Graded Hot-Mix Asphalt (Small Quantity)," to achieve required section.
- 4.6. **Finishing.** Regrade and compact disturbed topsoil. Clean roadway surface after repair operations.

5. MEASUREMENT

This Item will be measured by the square yard. In areas where material is excavated, as directed, to depths greater than those specified on the plans, measurement will be made by dividing the actual depth of such area by the plan depth and then multiplying this figure by the area in square yard of work performed. Calculations for each repaired area will be rounded up to the nearest 1/10 sq. yd. At each repair location, the minimum area for payment purposes will be 1 sq. yd.

The minimum quantity for Contracts with callout work is 5 sq. yd. per callout unless otherwise shown on the plans.

6. PAYMENT

The work performed and materials furnished in accordance with this Item and measured as provided under "Measurement" will be paid for at the unit price bid for "Flexible Pavement Structure Repair" of the specified depth. This price is full compensation for scarifying, removing, hauling, spreading, disposing of, and stockpiling existing pavement structure; removing objectionable or unstable material; furnishing and placing materials; maintaining completed section before surfacing; applying tack or prime coat; hauling, sprinkling, spreading, and compacting; and equipment, labor, tools, and incidentals.

Item 354

Planing and Texturing Pavement



1. DESCRIPTION

Plane, or plane and texture, existing asphalt concrete pavement, asphalt-stabilized base, or concrete pavement. Texture bridge deck surfaces.

2. EQUIPMENT

The Engineer may require demonstration of the equipment's capabilities.

2.1. **Planing Machine.** Use planing machines that:

- have a minimum 6-ft. cutting width except for work areas less than 6 ft. wide;
- are self-propelled with enough power, traction, and stability to maintain an accurate depth of cut and slope;
- can cut in one continuous operation: 4 in. of asphalt concrete pavement, 1 in. of concrete pavement, or a combination of 2 in. of asphalt concrete pavement and 1/2 in. of concrete pavement;
- use dual longitudinal controls capable of operating on both sides automatically from any longitudinal grade reference, which includes string line, ski, mobile string line, or matching shoe;
- use transverse controls with an automatic system to control cross slope at a given rate;
- use integral loading and reclaiming devices to allow cutting, removal, and discharge of the material into a truck in one operation; and
- include devices to control dust created by the cutting action.

2.2. **Manual System.** Use a manual system that can achieve a uniform depth of cut, flush to all inlets, valve covers, manholes, and other appurtenances within the paved area. Use of a manual system is allowed for areas restricted to self-propelled access and for detail pavement removal.

2.3. **Sweeper.** Use a street sweeper to remove cuttings and debris from the planed or textured pavement unless otherwise approved. Equip the sweeper with a water tank, dust control spray assembly, both a pick-up and a gutter broom, and a debris hopper.

3. CONSTRUCTION

3.1. **Grade Reference.** Place grade reference points at maximum intervals of 50 ft. in accordance with Item 5, "Control of the Work," when required. Use the control points to set the grade reference. Support the grade reference so the maximum deflection does not exceed 1/16 in. between supports.

3.2. **Planing and Texturing.** Vary the speed of the machine to leave a grid or other pattern type with discontinuous longitudinal reach. Remove the pavement surface for the length, depth, and width shown on the typical section and to the established line and grades. Remove pavement to vertical lines adjacent to curbs, gutters, inlets, manholes, or other obstructions. Do not damage appurtenances or underlying pavement. Provide a planed surface that has a uniform textured appearance and riding surface. Surface should be free from gouges, continuous longitudinal grooves, ridges, oil film, and other imperfections of workmanship. Leave a uniform surface of concrete pavement free of asphalt materials when removing an asphalt concrete pavement overlay.

Provide a minimum texture depth of not less than 0.05 in. when an overlay on the planed pavement is not required. Stop planing operations when surface texture depth is not sufficient. Plane no more than 3/16 in.

into the original deck surface on bridges. Never damage armor joints, sealed expansion joints, and other appurtenances.

Provide a pavement surface that, after planing, has a smooth riding quality and is true to the established line, grade, and cross-section. Provide a pavement surface that does not vary more than 1/8 in. in 10 ft. Evaluate this criterion with a 10-ft. straightedge placed parallel to the centerline of the roadway. Deviations will be measured from the top of the texture. Correct any point in the surface not meeting this requirement.

Sweep pavement and gutter. Leave pavement and curb clean.

- 3.3. **Edge Treatments.** Slope vertical or near vertical longitudinal faces in the pavement surface for areas under traffic in accordance with the requirements on the plans at the end of the day. Taper transverse faces to provide an acceptable ride.
- 3.4. **Salvaged Materials.** The Department will retain ownership of planed materials unless otherwise shown on the plans. Stockpile salvaged materials at locations shown on the plans. Prepare the stockpile site by removing vegetation and trash and providing proper drainage. Keep salvaged paving material free from contamination during its removal, transportation, and storage. Place different types or quality of salvaged asphalt paving material into separate stockpiles. Dispose of unsalvageable material in accordance with applicable federal, state, and local regulations.

4. MEASUREMENT

This Item will be measured by the square yard of surface area for each pavement type including asphalt concrete pavement, concrete pavement, and bridge decks. Measurement will be based on the depth shown for each bid item, within the limits shown on the plans, regardless of the number of passes required. Only 1 bid item for each pavement type will apply to any 1 location.

5. PAYMENT

The work performed and materials furnished in accordance with this Item and measured as provided under "Measurement" will be paid for at the unit price bid for "Planing and Texturing Asphalt Concrete Pavement," "Planing and Texturing Concrete Pavement," "Planing Asphalt Concrete Pavement," or "Planing Concrete Pavement" of the depths specified, and for "Texturing Bridge Decks."

The planing of concrete pavement to remove all asphalt concrete pavement as required under Article 354.3., "Construction," is subsidiary to the planing of asphalt concrete pavement of the depth shown on the plans.

This price is full compensation for removing all material to the depth shown; texturing the pavement surface when texturing is shown in the bid item description; loading, hauling, and unloading; stockpiling or disposing of material; sweeping; tapering or sloping longitudinal or transverse joints as described under Section 354.3.3., "Edge Treatments"; and equipment, labor, tools, and incidentals. Demonstration work to receive approval for use of equipment will not be paid for unless work is performed in accordance with the Contract and is accepted.

Item 356

Fabric Underseal



1. DESCRIPTION

Furnish and place fabric underseal in a longitudinal, full-road-width application or over pavement joints.

2. MATERIALS

2.1. Longitudinal, Full-Width Underseal.

2.1.1. **Fabric.** Provide fabric meeting DMS-6220, "Fabric for Underseals." Use roll widths shown on the plans or as approved.

2.1.2. **Asphalt.** Provide the grade of asphalt shown on the plans and in accordance with Item 300, "Asphalts, Oils, and Emulsions."

2.1.3. **Blotter.** Provide screenings, natural sand, or other materials as approved.

2.2. **Pavement Joint Underseal.** Provide material in accordance with DMS-6220, "Fabric For Underseals," or DMS-6260, "Reinforced Fabric Joint Underseal," as specified on the plans. Use roll widths as shown on the plans or as approved.

3. EQUIPMENT

Provide applicable equipment in accordance with Item 316, "Seal Coat," for longitudinal, full-width underseal.

4. CONSTRUCTION

Apply fabric underseal when the air temperature is 60°F and above, or above 50°F and rising. Never apply when surface temperature is below 50°F. Do not apply when, according to the Engineer, weather conditions are not suitable. Measure air temperature in the shade and away from artificial heat.

4.1. Longitudinal, Full-Width Underseal.

4.1.1. **Surface Preparation.** Prepare the surface by cleaning off dirt, dust, or other debris. Set string lines for alignment if required. Remove existing raised pavement markers in accordance with the plans. Remove vegetation and blade pavement edges when shown on the plans.

4.1.2. **Asphalt Binder Application.** Apply asphalt binder:

- with an asphalt distributor unless otherwise approved,
- at the rate shown on the plans or as directed,
- within 15°F of the temperature selected by the Engineer,
- approximately 6 in. outside the fabric width, and
- with paper or other approved material at the beginning and end of each shot to construct a straight transverse joint and to prevent overlapping of the asphalt.

Match longitudinal joints with the lane lines unless otherwise approved. The Engineer may require a string line if necessary to keep joints straight with no overlapping. Never contaminate asphalt binder.

- 4.1.3. **Fabric Placement.** Align the fabric and broom or roll it in place immediately after asphalt binder application. Cut the fabric, overlap the cut fabric to create a transverse joint, and begin application again if skewed alignment occurs. Roll or broom fabric onto the asphalt binder in a manner that prevents air bubbles from forming under the fabric. Provide an alternate means of securing the edges to the pavement if wind prevents proper adherence of the fabric to the asphalt binder, especially at the edges. Cease underseal application if it is determined that wind conditions prevent proper placement.
- 4.1.3.1. **Transverse Joints.** Overlap transverse joints by a minimum of 6 in. Make all transverse joints with the top layer in the direction of traffic if traffic is allowed directly on the underseal. Secure ends of overlapping fabric layer at transverse joints by nailing or other approved means.
- 4.1.3.2. **Longitudinal Joints.** Overlap longitudinal joints by a minimum of 4 in. Apply additional asphalt binder to secure longitudinal fabric joints.
- 4.1.4. **Blotter.** Apply blotter as directed to the top of the underseal to absorb excess asphalt binder. Remove any excess blotter as directed.
- 4.2. **Pavement Joint Underseal.**
- 4.2.1. **Surface Preparation.** Remove dirt, dust, or other debris from all joints and from the area on both sides of the joint that will be in contact with the installed underseal. Other preparation for proper adherence may be required as shown on the plans.
- 4.2.2. **Fabric Placement.** Do not allow joints or laps in the underseal material for transverse pavement joints. Minimize underseal material joints in longitudinal pavement joints, and do not allow overlap. Center the fabric width over the joint. Apply fabric to the joint with a minimum of 5 in. on each side or as specified on the plans. Do not allow air bubbles under the fabric.
- 4.2.2.1. **Non-Woven Fabric and Binder.** Apply asphalt binder as directed in Section 356.4.1.2., "Asphalt Binder Application." Place fabric as directed in Section 356.4.1.3., "Fabric Placement," except do not allow joints or laps in the underseal material along transverse pavement joints.
- 4.2.2.2. **Reinforced Joint Fabric.** Remove any protective coatings from the adhering layer of the fabric underseal. Roll fabric in place to ensure adherence of the self-adhering binder.

5. MEASUREMENT

- 5.1. **Longitudinal, Full-Width Underseal.**
- 5.1.1. **Asphalt Binder.** Asphalt binder will be measured as follows:
- 5.1.1.1. **Volume.** Volume measurements will be made at the point of application on the road as gallons used at the application temperature, as directed, in the accepted fabric underseal.
- 5.1.1.2. **Weight.** Weight measurements will be by the ton in accordance with Item 520, "Weighing and Measuring Equipment." At the end of the project, deduct any remaining material from quantities delivered to determine pay quantities.
- 5.1.2. **Fabric.** Fabric will be measured by the square yard based on the widths shown on the plans and the lengths measured at placement with no allowance for overlapping at transverse and longitudinal joints.
- 5.2. **Pavement Joint Underseal.** Pavement joint underseal will be measured by the foot.

6. PAYMENT

The work performed and materials furnished in accordance with this Item and measured as provided under "Measurement" are paid for at the unit bid price for "Asphalt Binder" of the type and grade specified and for "Fabric" for full-width underseals and "Pavement Joint Underseal" of the product width specified for pavement joint underseals. These prices are full compensation for cleaning and preparing the existing pavement, including removal of raised pavement markers; furnishing, preparing, hauling, and placing materials, including blotter; manipulation, including rolling and brooming; and equipment, labor, tools, and incidentals.

Item 358

Hot In-Place Recycling of Asphalt Concrete Surfaces



1. DESCRIPTION

Use the hot in-place process to recycle the existing pavement in one of the following sub-categories described below.

- 1.1. **Recycling.** Recycling is the process in which the existing asphalt pavement is heated, softened and then milled. A recycling agent is added and the material is thoroughly mixed and placed with a standard paving screed.
- 1.2. **Remixing.** Remixing is similar to recycling with the addition of virgin aggregate or new hot-mix asphalt (HMA) added to the recycled material. The materials are then thoroughly mixed and placed with a standard paving screed.
- 1.3. **Repaving.** Repaving combines either recycling or remixing with an overlay of new HMA placed immediately after the recycled mixture. The new HMA layer is placed directly on the recycled layer, and both are compacted simultaneously.

The Department will provide on the plans all typical sections and any grade change requirements; the depth and width of recycling required; core information from the existing roadway to include pavement layers, lift thicknesses; the asphalt content and penetration value of the existing asphalt to be recycled; and any other data collected from the pavement evaluation.

2. MATERIALS

- 2.1. **Recycling Agent.** Furnish a recycling agent in accordance with Section 358.4.2., "Mixture Design," and meeting the requirements of Section 300.2.6., "Recycling Agent." Other recycling agents may be allowed when approved or required when directed or shown on the plans.
- 2.2. **Hot-Mix Asphalt.** If the process requires additional HMA, furnish new HMA that meets the requirements of Section 358.4.2., "Mixture Design." Use materials meeting the requirements of Article 340.2., "Materials," to produce the new HMA. Other HMA mixture types are allowed when shown on the plans.
- 2.3. **Aggregate.** If the process requires additional aggregate, furnish aggregates to meet the requirements shown in Section 358.4.2., "Mixture Design." Use aggregates meeting the requirements of Article 340.2., "Materials."

3. EQUIPMENT

Provide required or necessary equipment in accordance with Item 320, "Equipment for Asphalt Concrete Pavement."

- 3.1. **Processing Equipment.** Provide equipment that is capable of a continuous single pass, multi-step operation, including heating; milling; introducing recycling agent, virgin materials, or HMA (if determined necessary); mixing the reclaimed material; redistributing the recycled material; placing the mix and leveling it with an asphalt paver or paving screed; and compacting the mixture, that meets the following requirements.
 - 3.1.1. **Pavement Pre-Heaters.** Supply pavement pre-heaters capable of uniformly heating the existing pavement to a temperature high enough to remove excess moisture and allow dislodging of the material to the specified depth, while minimizing the fracturing of aggregate particles. Equip heaters with an enclosed or shielded

hood to prevent damage to adjacent property or vegetation. Ensure that the heaters overlap the completed adjacent lane by a minimum of 6 in. to create a hot bond at the longitudinal joint.

- 3.1.2. **Pavement Milling Heads.** Provide milling heads for pavement recycling capable of uniformly loosening the entire pavement lane width to the depth specified on the plans. Accomplish the recycling by using milling heads that have a grade control system for each head. Ensure that the tooth spacing of the milling heads is enough to allow material to pass without excessive retention. Use equipment that is capable of raising and lowering the milling heads to recycle the material around manholes and other obstacles.

Equip the milling heads such that they are capable of gathering the heated and loosened asphalt concrete pavement. Operate the milling heads in such a manner to minimize aggregate degradation. Use milling heads that are capable of creating a windrow of the milled material ahead of the mixing chamber or subsequent milling units.

- 3.1.3. **Recycling Agent Application System.** Provide a system for adding and uniformly applying a recycling agent at the specified rate to the hot, loosened material. Control the system to within 5.0% of the target application rate. Equip the recycling agent system with positive on/off capabilities to prevent any dripping. Add the recycling agent during or after milling has taken place to provide uniform application of the recycling agent and adequate mixing with the recycled material during the mixing cycle.

- 3.1.4. **Mixing Unit.** Provide equipment with an on-board mixing chamber that is capable of thoroughly mixing the heated, reworked material with new materials. Enclose and configure the mixing chamber such that no milled material escapes or bypasses the mixer chamber. Ensure that the rotation of the mixer apparatus does not cause segregation during the mixing process.

- 3.1.5. **Paving Unit.** Furnish a paver or paver screed meeting the requirements of Section 320.2.3.1., "Asphalt Paver."

- 3.2. **Rollers.** Provide rollers meeting the requirements of Article 210.2., "Equipment."

- 3.3. **Broom.** Furnish rotary self-propelled power brooms. The broom should have positive control on the downward pressure applied to the surface.

- 3.4. **Field Laboratory.** Unless otherwise shown on the plans, furnish a mobile testing laboratory meeting the requirements of Tex-237-F and a Level 1A certified laboratory technician qualified under the Department's approved program. If fresh HMA is added, perform the tests necessary to control plant production.

4. CONSTRUCTION

Rehabilitate existing asphalt concrete pavement to meet the typical sections shown on the plans and the lines and grades established. The existing pavement should be heated and milled to the required depth of treatment as shown on the plans.

- 4.1. **Certification.** Personnel certified by a Department-approved hot-mix certification program must conduct all mixture designs, sampling, and testing. Supply a list of certified personnel and copies of their current certificates before beginning production and when personnel changes are made.
- 4.2. **Mixture Design.** Design a mixture to meet the requirements listed in Table 1 using a Superpave Gyratory Compactor. Compact specimens at the anticipated production temperature between 200°F and 250°F at 50 gyrations in accordance with Tex-241-F. The target number of gyrations may be adjusted when approved. Submit the completed mix design for approval before the start of the project. Perform additional mix designs based on road variability, as directed.
- 4.2.1. **Sampling.** Before bidding, the Engineer will provide material and pavement information obtained from roadway cores, such as layer thicknesses, gradation, asphalt content and recovered asphalt penetration of the pavement to be recycled using the Construction Division's protocol and guidelines. Additional cores may

be taken by potential Bidders to obtain further information on the material to be recycled when approved. After the project is awarded, obtain an adequate amount of roadway cores throughout the project to perform the mixture design and to determine the existing condition of the roadway to account for any variability within the project limits. Evaluate the material from the roadway cores and document any existing material that could be detrimental to the process (rubber seal, fabric underseal, etc.). A minimum of 2 in. of the existing pavement structure must remain in place following milling. Document any base or uncoated material within the layer to be recycled. Provide documentation of any of these conditions before proceeding with the mixture design.

- 4.2.2. **Job-Mix Formula Approval.** The job-mix formula (JMF) is the combined aggregate gradation and target asphalt recycling agent percentage established from the laboratory mixture design.
- 4.2.3. **Hot-Mix Asphalt.** If the process requires new HMA, use materials meeting the requirements of Section 340.4.3., "Mixture Design," or as shown on the plans. Document in the JMF the percentage of new HMA used in the laboratory mix design submitted.
- 4.2.4. **Aggregates.** If necessary, use aggregates meeting the requirements in Table 1 of Article 340.2., "Materials," or as shown on the plans.
- 4.2.5. **Additives.** Other additives may be allowed to meet the requirements in Table 1. When other additives are used, document the type and percentage in the mixture design submittal.

Table 1
Laboratory Mix Design Properties

Mixture Property	Test Method	Requirement
Design gyrations (N _{design})	Tex-241-F	50
Laboratory-molded density, %	Tex-207-F & Tex-227-F	Note ¹
Indirect tensile strength, psi ²	Tex-226-F	75–200
Hamburg Wheel-tracking Test, minimum number of passes at 12.5 mm rut depth	Tex-242-F	10,000
Overlay test, minimum number of cycles	Tex-248-F	150 ³
Boil Test ²	Tex-530-C	-
Combined Asphalt Property	Test Method	Requirement
Penetration, 77°F, 100 g, 5 sec.	T49	40–80

1. For informational purposes only.
2. Used to establish a baseline for comparison to production test results.
3. May be reduced when approved.

- 4.3. **Pavement Heating.** Heat the existing pavement without charring the pavement surface and without producing undesirable pollutants. Maintain a minimum temperature of 200°F of the material immediately behind the heater. Uniformly heat the pavement surface across its full lane width such that cold milling of the pavement surface does not occur.
- 4.4. **Pavement Milling.** Mill the existing pavement to the required depth and width as indicated on the plans. Do not disturb the underlying material in the existing roadway when recycling. Remove grass and other vegetation from the edge of the existing pavement to prevent contamination of the recycled bituminous material during this operation.

Use the milling heads to remove a minimum of 3 in. laterally of the completed adjacent pass and make a square vertical cut in the heated material to achieve a hot bonded longitudinal joint. Ensure all material across the full lane-width is processed between consecutive lane passes to assure any wedges (slivers) of unprocessed materials are not left untouched by the milling heads and covered by the recycled material, unless otherwise approved.

Ensure the temperature of the milled surface directly behind the milling heads is greater than 160°F so cold milling does not occur. Clean all loosened asphalt material away by the milling heads, and a milling tooth pattern must be clearly visible after milling.

Remove all material around manholes and utility structures before paving the recycled mixture to allow for the plan depth of the pavement around these structures.

Cold mill and sweep clean any areas that cannot be heated and milled by the recycling equipment. Properly tack and pave these areas of cold milling in advance of the recycling process.

- 4.5. **Addition of Recycling Agent.** Incorporate the asphalt recycling agent into the hot recycled bituminous material at the rate determined by the approved mix designs. Sampling and testing during mixture production may result in varying quantities of recycling agent at different portions of the project to meet the requirements in Table 1. Change the recycling agent content only as approved.
- 4.6. **Placement of Recycled Material.** Spread the material using a paver and screed attached to the mixing/milling unit or a traditional paver in a separate and continuous operation meeting the requirements of Section 320.2.3.1., "Asphalt Paver." Spread the recycled material to the established lines and grades. Ensure the temperature of the recycled material behind paver is greater than 200°F.
- 4.7. **Compaction.** Uniformly compact the pavement to contain between 3.8% and 8.5% in-place air voids.
- Furnish the type, size, and number of rollers required for compaction as approved and meeting the requirements of Article 210.2., "Equipment." Use a pneumatic-tire roller to seal the surface unless excessive pickup of fines occurs. Use additional rollers as required to remove any roller marks. Use only water or an approved release agent on rollers, tamps, and other compaction equipment unless otherwise directed.
- On the first day of production, use the control strip method given in Tex-207-F, Part IV, to establish the rolling pattern that will produce the desired in-place air voids unless otherwise directed.
- Operate rollers in vibratory mode only when doing so does not damage the pavement. Establish a new rolling pattern when changes occur in the recycled mix or placement conditions. Adjust or cease compaction when cracking or displacement occurs. Ensure that pavement is fully compacted before allowing rollers to park on the pavement.
- 4.8. **Traffic.** Allow the compacted pavement to cool to 160°F or lower before opening to traffic unless otherwise directed. Maintain the surface of the recycled pavement in a condition suitable for the safe movement of traffic. Power broom the pavement surface to remove all loose particles if needed.
- 4.9. **Irregularities.** Identify and correct irregularities, including but not limited to segregation, rutting, raveling, flushing, fat spots, mat slippage, irregular color, irregular texture, roller marks, tears, gouges, streaks, uncoated aggregate particles, or broken aggregate particles. The Engineer may also identify irregularities, and in such cases, the Engineer will promptly notify the Contractor. If the Engineer determines that the irregularity will adversely affect pavement performance, the Engineer may require the Contractor to remove and replace (at the Contractor's expense) areas of the pavement that contain irregularities and areas where the mixture does not bond to the existing pavement. If irregularities are detected, the Engineer may require the Contractor to immediately suspend operations or may allow the Contractor to continue operations for no more than one day while the Contractor is taking appropriate corrective action.
- 4.10. **Curing.** A surface treatment may be allowed as the final riding surface when shown on the plans. Cure the hot in-place recycled bituminous material for a minimum of 7 days, or as directed when HMA or another applicable surface treatment is placed as a surface course.
- 4.11. **Weather Conditions.** Unless otherwise approved, perform hot in-place recycling operations when the existing pavement surface temperature is 60°F or higher and when weather conditions and moisture conditions of the roadway surface are suitable, in the opinion of the Engineer. Measure the roadway surface temperature with a handheld infrared thermometer. The Engineer may allow mixture placement to begin before the roadway surface reaching the required temperature requirements, if conditions are such that the roadway surface will reach the required temperature within 2 hr. of beginning placement operations.

5. PRODUCTION ACCEPTANCE

- 5.1. **Production Lot.** Each day of production is defined as a production lot. Lots will be sequentially numbered and will correspond to each new day of production. Note that lots are not subdivided into sublots for this specification.
- 5.2. **Production Sampling.**
- 5.2.1. **Mixture Sampling.** The Engineer may obtain mixture samples in accordance with Tex-222-F at any time during production.
- 5.2.2. **Recycling Agent Sampling.** The Engineer may obtain or require the Contractor to obtain 1-qt. samples of the recycling agent at any time during production in accordance with Tex-500-C, Part III. The Engineer may test any of the samples to verify compliance with Item 300, "Asphalts, Oils, and Emulsions."
- 5.3. **Production Testing.** The Engineer will test at the frequency listed in Table 2. The Engineer may suspend production if production tests do not meet specifications or are not within operational tolerances listed in Table 2. The Engineer may suspend operations if the Contractor's corrective actions do not produce acceptable results. The Engineer will allow production to resume when the proposed corrective action is likely to yield acceptable results.

Table 2
Operational Tolerance and Minimum Testing Frequency

Description	Test Method	Allowable Difference from JMF Target	Minimum Testing Frequency	
			Contractor	Engineer
Asphalt binder content, %	Tex-236-F	±0.5	1 per lot	1 per lot
Theoretical max spec. (Rice) gravity	Tex-227-F	N/A	1 per lot	1 per 5 lots
Laboratory-molded density, %	Tex-207-F	±1.0	1 per lot	1 per 5 lots
Hamburg Wheel-tracking test, 50°C, mm	Tex-242-F	N/A ¹	1 per 5 lots	1 per project
Boil test	Tex-530-C	N/A ²	1 per lot	1 per project
Air voids	Tex-207-F	N/A ³	1 per lot	1 per lot

1. Hamburg values must not exceed 12.5 mm in 10,000 passes, unless otherwise directed.
2. Compare with sample from mix design to determine amount of stripping.
3. In-place air voids should be between 3.8% and 8.5%.

- 5.4. **Total Asphalt Binder Content.** Adjust the asphalt recycling content based upon mix design recommendations for varying roadway conditions to meet the requirements in Table 2.

6. PLACEMENT ACCEPTANCE

- 6.1. **Placement Lot.** A placement lot is defined as the area placed during a production lot (one day's production). Placement lot numbers will correspond with production lot numbers.
- 6.2. **Placement Sampling.** Provide the equipment and means to obtain and trim roadway cores on-site. On-site is defined as in close proximity to where the cores are taken. Obtain the cores within one working day of the time the placement lot is completed unless otherwise approved. Unless otherwise shown on the plans, obtain two 6-in. diameter cores side-by-side at each location selected by the Engineer for in-place air void determination. Mark the cores for identification, measure and record the untrimmed core height, and provide the information to the Engineer. The Engineer will witness the coring operation and measurement of the core thickness. Visually inspect each core and verify that the current paving layer is bonded to the underlying layer. If an adequate bond does not exist between the current and underlying layer, take corrective action to ensure that an adequate bond will be achieved during subsequent placement operations.

Trim the cores after obtaining the cores from the roadway in accordance with Tex-207-F if the core heights meet the minimum untrimmed shown on the plans. Trim the cores on-site in the presence of the Engineer. Use a permanent marker or paint pen to record the date and lot number on each core as well as the

designation as Core A or B. The Engineer may require additional information to be marked on the core and may choose to sign or initial the core. The Engineer will take custody of the cores immediately after they are trimmed and will retain custody of the cores until the Department's testing is completed. Before turning the trimmed cores over to the Engineer, the Contractor may elect to wrap the trimmed cores or secure them in a manner that will reduce the risk of possible damage occurring during transport by the Engineer. After testing, the Engineer will return the cores to the Contractor.

The Engineer may elect to have the cores transported back to the Department's laboratory at the HMA plant via the Contractor's haul truck or other designated vehicle. In such cases where the cores will be out of the Engineer's possession during transport, the Engineer will use Department-provided security bags and the Roadway Core Custody protocol located at <http://www.txdot.gov/business/specifications.htm> to provide a secure means and process that protects the integrity of the cores during transport.

Instead of the Contractor trimming the cores on-site immediately after coring, the Engineer and the Contractor may mutually agree to have the trimming operations performed at an alternate location such as a field laboratory or other similar location. In such cases, the Engineer will take possession of the cores immediately after they are obtained from the roadway and will retain custody of the cores until testing is completed. Either the Department or Contractor representative may perform trimming of the cores. The Engineer will witness all trimming operations in cases where the Contractor representative performs the trimming operation.

Dry the core holes and tack the sides and bottom immediately after obtaining the cores. Fill the hole with the same type of mixture and properly compact the mixture. Repair core holes with other methods when approved.

6.3. **Placement Testing.** The Engineer may measure in-place air voids at any time during the project to verify specification compliance.

6.3.1. **In-Place Air Voids.** The Engineer will measure in-place air voids in accordance with Tex-207-F and Tex-227-F. Before drying to a constant weight, cores may be pre-dried using a Corelok or similar vacuum device to remove excess moisture. The Engineer will use the corresponding theoretical maximum specific gravity to determine the air void content of each core. The Engineer will use the average air void content of the 2 cores to determine the in-place air voids at the selected location.

The Engineer will use the vacuum method to seal the core if required by Tex-207-F. The Engineer will use the test results from the unsealed core if the sealed core yields a higher specific gravity than the unsealed core.

When the in-place air voids exceed the range of 3.8% and 8.5%, take immediate corrective action to bring the operation within these tolerances. The Engineer may suspend operations or require removal and replacement if the in-place air voids are less than 2.7% or greater than 9.9%. The Engineer will allow paving to resume when the proposed corrective action is likely to yield between 3.8% and 8.5% in-place air voids.

6.3.2. **New Hot-Mix Asphalt.** If applicable, control the quantity of new HMA added to the recycled mix from haul tickets to within 5.0% of the target JMF.

6.3.3. **Depth of Recycled Material.** Maintain the required nominal depth on both outside vertical faces and in the center of the recycled area. Manually measure and report recorded depths each 1/4 mile approximately each hour of production. Measure from the bottom of the mill pass to the top of the surface placed.

6.4. **Ride Quality.** Use Surface Test Type A to evaluate ride quality in accordance with Item 585, "Ride Quality for Pavement Surfaces," unless otherwise shown on the plans.

7. MEASUREMENT

Hot in-place recycling of asphalt concrete surface will be measured by the square yard. The dimensions for determining the surface areas are established by the depths and widths shown on the plans and the lengths measured at placement.

Recycling agent will be measured at the applied temperature by the gallon from strap depths measured from the calibrated strap stick for each load or other approved automated means.

New HMA will be measured by the ton of composite mix, which includes asphalt, aggregate, and additives. Measure the new HMA on scales in accordance with Item 520, "Weighing and Measuring Equipment."

8. PAYMENT

Hot in-place recycling of asphalt concrete surfaces will be paid for at the unit bid price for "Hot In-Place Recycling of Asphalt Concrete (Surface)" of the depth specified.

Asphalt recycling agent will be paid for separately at the unit bid price for "Hot In-Place Recycling of Asphalt Concrete (Recycling Agent)."

New HMA will be paid for at the unit price bid for "Hot In-Place Recycling of Asphalt Concrete (Mix)."

This price is full compensation for the removal and processing of the existing pavement; for preparing, hauling, and placing materials; for all freight involved; for all manipulations, including rolling and brooming; and for all labor, tools, equipment, and incidentals necessary to complete the work. This price also includes any surface treatment that is allowed on the plans but not required to complete the above work.

Item 360

Concrete Pavement



1. DESCRIPTION

Construct hydraulic cement concrete pavement with or without curbs on the concrete pavement.

2. MATERIALS

- 2.1. **Hydraulic Cement Concrete.** Provide hydraulic cement concrete in accordance with Item 421, "Hydraulic Cement Concrete." Use compressive strength testing unless otherwise shown on the plans. Provide Class P concrete designed to meet a minimum average compressive strength of 3,200 psi or a minimum average flexural strength of 450 psi at 7 days or a minimum average compressive strength of 4,000 psi or a minimum average flexural strength of 570 psi at 28 days. Test in accordance with Tex-448-A or Tex-418-A.

Obtain written approval if the concrete mix design exceeds 520 lb. per cubic yard of cementitious material.

Use coarse aggregates for continuously reinforced concrete pavements to produce concrete with a coefficient of thermal expansion not more than 5.5×10^{-6} in./in./°F. Provide satisfactory Tex-428-A test data from an approved testing laboratory if the coarse aggregate coefficient of thermal expansion listed on the Department's *Concrete Rated Source Quality Catalog* is not equal to or less than 5.5×10^{-6} in./in./°F.

Provide Class HES concrete for very early opening of small pavement areas or leave-outs to traffic when shown on the plans or allowed. Design Class HES to meet the requirements of Class P and a minimum average compressive strength of 3,200 psi or a minimum average flexural strength of 450 psi in 24 hr., unless other early strength and time requirements are shown on the plans or allowed.

Use Class A or P concrete meeting the requirements of Item 421, "Hydraulic Cement Concrete," and this Item for curbs that are placed separately from the pavement.

- 2.2. **Reinforcing Steel.** Provide Grade 60 or above, deformed steel for bar reinforcement in accordance with Item 440, "Reinforcement for Concrete." Provide positioning and supporting devices (baskets and chairs) capable of securing and holding the reinforcing steel in proper position before and during paving. Provide corrosion protection when shown on the plans.
- 2.2.1. **Dowels.** Provide smooth, straight dowels of the size shown on the plans, free of burrs, and conforming to the requirements of Item 440, "Reinforcement for Concrete." Coat dowels with a thin film of grease, wax, silicone or other approved de-bonding material. Provide dowel caps on the lubricated end of each dowel bar used in an expansion joint. Provide dowel caps filled with a soft compressible material with enough range of movement to allow complete closure of the expansion joint.
- 2.2.2. **Tie Bars.** Provide straight deformed steel tie bars. Provide either multiple-piece tie bars or single-piece tie bars as shown on the plans. Furnish multiple piece tie bar assemblies from the list of approved multiple-piece tie bars that have been prequalified in accordance with DMS-4515 "Multiple Piece Tie Bars for Concrete Pavements," when used. Multiple-piece tie bars used on individual projects must be sampled in accordance with Tex-711-I, and tested in accordance with DMS-4515 "Multiple Piece Tie Bars for Concrete Pavements."
- 2.3. **Alternative Reinforcing Materials.** Provide reinforcement materials of the dimensions and with the physical properties specified when allowed or required by the plans. Provide manufacturer's certification of required material properties.

- 2.4. **Curing Materials.** Provide Type 2 membrane curing compound conforming to DMS-4650, "Hydraulic Cement Concrete Curing Materials and Evaporation Retardants." Provide SS-1 emulsified asphalt conforming to Item 300, "Asphalts, Oils, and Emulsions," for concrete pavement to be overlaid with asphalt concrete under this Contract unless otherwise shown on the plans or approved. Provide materials for other methods of curing conforming to the requirements of Item 422, "Concrete Superstructures." Provide insulating blankets for curing fast track concrete pavement with a minimum thermal resistance (R) rating of 0.5 hour-square foot F/BTU. Use insulating blankets that are free from tears and are in good condition.
- 2.5. **Epoxy.** Provide Type III, Class C epoxy in accordance with DMS-6100, "Epoxies and Adhesives," for installing all drilled-in reinforcing steel. Submit a work plan and request approval for the use of epoxy types other than Type III, Class C.
- 2.6. **Evaporation Retardant.** Provide evaporation retardant conforming to DMS-4650., "Hydraulic Cement Concrete Curing Materials and Evaporation Retardants."
- 2.7. **Joint Sealants and Fillers.** Provide Class 5 or Class 8 joint-sealant materials and fillers unless otherwise shown on the plans or approved and other sealant materials of the size, shape, and type shown on the plans in accordance with DMS-6310, "Joint Sealants and Fillers."

3. EQUIPMENT

Furnish and maintain all equipment in good working condition. Use measuring, mixing, and delivery equipment conforming to the requirements of Item 421, "Hydraulic Cement Concrete." Obtain approval for other equipment used.

- 3.1. **Placing, Consolidating, and Finishing Equipment.** Provide approved self-propelled paving equipment that uniformly distributes the concrete with minimal segregation and provides a smooth machine-finished consolidated concrete pavement conforming to plan line and grade. Provide an approved automatic grade control system on slip-forming equipment. Provide approved mechanically-operated finishing floats capable of producing a uniformly smooth pavement surface. Provide equipment capable of providing a fine, light water fog mist.

When string-less paving equipment is used, use Section 5.9.3, "Method C," and establish control points at maximum intervals of 500 ft. Use these control points as reference to perform the work.

Provide mechanically-operated vibratory equipment capable of adequately consolidating the concrete. Provide immersion vibrators on the paving equipment at sufficiently close intervals to provide uniform vibration and consolidation of the concrete over the entire width and depth of the pavement and in accordance with the manufacturer's recommendations. Provide immersion vibrator units that operate at a frequency in air of at least 8,000 cycles per minute. Provide enough hand-operated immersion vibrators for timely and proper consolidation of the concrete along forms, at all joints and in areas not covered by other vibratory equipment. Surface vibrators may be used to supplement equipment-mounted immersion vibrators. Provide tachometers to verify the proper operation of all vibrators.

For small or irregular areas or when approved, the paving equipment described in this Section is not required.

- 3.2. **Forming Equipment.**
- 3.2.1. **Pavement Forms.** Provide metal side forms of sufficient cross-section, strength, and rigidity to support the paving equipment and resist the impact and vibration of the operation without visible springing or settlement. Use forms that are free from detrimental kinks, bends, or warps that could affect ride quality or alignment. Provide flexible or curved metal or wood forms for curves of 100-ft. radius or less.
- 3.2.2. **Curb Forms.** Provide curb forms for separately placed curbs that are not slipformed that conform to the requirements of Item 529, "Concrete Curb, Gutter, and Combined Curb and Gutter."

- 3.3. **Reinforcing Steel Inserting Equipment.** Provide inserting equipment that accurately inserts and positions reinforcing steel in the plastic concrete parallel to the profile grade and horizontal alignment in accordance to plan details when approved.
- 3.4. **Texturing Equipment.**
- 3.4.1. **Carpet Drag.** Provide a carpet drag mounted on a work bridge or a manual moveable support system. Provide a single piece of carpet of sufficient transverse length to span the full width of the pavement being placed and adjustable so that a sufficient longitudinal length of carpet is in contact with the concrete being placed to produce the desired texture. Obtain approval to vary the length and width of the carpet to accommodate specific applications.
- 3.4.2. **Tining Equipment.** Provide a self-propelled metal tine device equipped with steel tines with cross-section approximately 1/32 in. thick × 1/12 in. wide. Provide tines for transverse tining equipment spaced at approximately 1 in., center-to-center, or provide tines for longitudinal tining equipment spaced at approximately 3/4 in., center-to-center. Manual methods that produce an equivalent texture may be used when it is impractical to use self-propelled equipment, such as for small areas, narrow width sections, and in emergencies due to equipment breakdown.
- 3.5. **Curing Equipment.** Provide a self-propelled machine for applying membrane curing compound using mechanically-pressurized spraying equipment with atomizing nozzles. Provide equipment and controls that maintain the required uniform rate of application over the entire paving area. Provide curing equipment that is independent of all other equipment when required to meet the requirements of Section 360.4.9., "Curing." Hand-operated pressurized spraying equipment with atomizing nozzles may only be used on small or irregular areas, narrow width sections, or in emergencies due to equipment breakdown.
- 3.6. **Sawing Equipment.** Provide power-driven concrete saws to saw the joints shown on the plans. Provide standby power-driven concrete saws during concrete sawing operations.
- 3.7. **Grinding Equipment.** Provide self-propelled powered grinding equipment that is specifically designed to smooth and texture concrete pavement using circular diamond blades when required. Provide equipment with automatic grade control capable of grinding at least a 3-ft. width longitudinally in each pass without damaging the concrete.
- 3.8. **Testing Equipment.** Provide testing equipment regardless of job-control testing responsibilities in accordance with Item 421, "Hydraulic Cement Concrete," unless otherwise shown on the plans or specified.
- 3.9. **Coring Equipment.** Provide coring equipment capable of extracting cores in accordance with the requirements of Tex-424-A when required.
- 3.10. **Miscellaneous Equipment.** Furnish both 10-ft. and 15-ft. steel or magnesium long-handled, standard straightedges. Furnish enough work bridges, long enough to span the pavement, for finishing and inspection operations.

4. CONSTRUCTION

Obtain approval for adjustments to plan grade-line to maintain thickness over minor subgrade or base high spots while maintaining clearances and drainage. Maintain subgrade or base in a smooth, clean, compacted condition in conformity with the required section and established grade until the pavement concrete is placed. Keep subgrade or base damp with water before placing pavement concrete.

Adequately light the active work areas for all nighttime operations. Provide and maintain tools and materials to perform testing.

- 4.1. **Paving and Quality Control Plan.** Submit a paving and quality control plan for approval before beginning pavement construction operations. Include details of all operations in the concrete paving process, including

methods to construct transverse joints, methods to consolidate concrete at joints, longitudinal construction joint layout, sequencing, curing, lighting, early opening, leave-outs, sawing, inspection, testing, construction methods, other details and description of all equipment. List certified personnel performing the testing. Submit revisions to the paving and quality control plan for approval.

- 4.2. **Job-Control Testing.** Perform all fresh and hardened concrete job-control testing at the specified frequency unless otherwise shown on the plans. Provide job-control testing personnel meeting the requirements of Item 421, "Hydraulic Cement Concrete." Provide and maintain testing equipment, including strength testing equipment at a location acceptable to the Engineer. Use of a commercial laboratory is acceptable. Maintain all testing equipment calibrated in accordance with pertinent test methods. Make strength-testing equipment available to the Engineer for verification testing.

Provide the Engineer the opportunity to witness all tests. The Engineer may require a retest if not given the opportunity to witness. Furnish a copy of all test results to the Engineer daily. Check the first few concrete loads for slump and temperature to verify concrete conformance and consistency on start-up production days. Sample and prepare strength-test specimens (2 specimens per test) on the first day of production and for each 3,000 sq. yd. or fraction thereof of concrete pavement thereafter. Prepare at least 1 set of strength-test specimens for each production day. Perform slump and temperature tests each time strength specimens are made. Monitor concrete temperature to ensure that concrete is consistently within the temperature requirements. The Engineer will direct random job-control sampling and testing. Immediately investigate and take corrective action as approved if any Contractor test result, including tests performed for verification purposes, does not meet specification requirements.

The Engineer will perform job-control testing when the testing by the Contractor is waived by the plans; however, this does not waive the Contractor's responsibility for providing materials and work in accordance with this Item.

- 4.2.1. **Job-Control Strength.** Use 7-day job-control concrete strength testing in accordance with Tex-448-A or Tex-418-A unless otherwise shown on the plans or permitted.

Use a compressive strength of 3,200 psi or a lower job-control strength value proven to meet a 28-day compressive strength of 4,000 psi as correlated in accordance with Tex-427-A for 7-day job-control by compressive strength. Use a flexural strength of 450 psi or a lower job-control strength value proven to meet a 28-day flexural strength of 570 psi as correlated in accordance with Tex-427-A for 7-day job-control by flexural strength.

Job control of concrete strength may be correlated to an age other than 7 days in accordance with Tex-427-A when approved. Job-control strength of Class HES concrete is based on the required strength and time.

Investigate the strength test procedures, the quality of materials, the concrete production operations, and other possible problem areas to determine the cause when a job-control concrete strength test value is more than 10% below the required job-control strength or when 3 consecutive job-control strength values fall below the required job-control strength. Take necessary action to correct the problem, including redesign of the concrete mix if needed. The Engineer may suspend concrete paving if the Contractor is unable to identify, document, and correct the cause of low-strength test values in a timely manner. The Engineer will evaluate the structural adequacy of the pavements if any job-control strength is more than 15% below the required job-control strength. Remove and replace pavements found to be structurally inadequate at no additional cost when directed.

- 4.2.2. **Split-Sample Verification Testing.** Perform split-sample verification testing with the Engineer on random samples taken and split by the Engineer at a rate of at least 1 for every 10 job-control samples. The Engineer will evaluate the results of split-sample verification testing. Immediately investigate and take corrective action as approved when results of split-sample verification testing differ more than the allowable differences shown in Table 1, or the average of 10 job-control strength results and the Engineer's split-sample strength result differ by more than 10%.

Table 1
Verification Testing Limits

Test Method	Allowable Differences
Temperature, Tex-422-A	2°F
Flexural strength, Tex-448-A	19%
Compressive strength, Tex-418-A	10%

- 4.3. **Reinforcing Steel and Joint Assemblies.** Accurately place and secure in position all reinforcing steel as shown on the plans. Place dowels at mid-depth of the pavement slab, parallel to the surface. Place dowels for transverse contraction joints parallel to the pavement edge. Tolerances for location and alignment of dowels will be shown on the plans. Stagger the lap locations so that no more than 1/3 of the longitudinal steel is spliced in any given 12-ft. width and 2-ft. length of the pavement. Use multiple-piece tie bars, drill and epoxy grout tie bars, or, if approved, mechanically-inserted single-piece tie bars at longitudinal construction joints. Verify that tie bars that are drilled and epoxied or mechanically inserted into concrete at longitudinal construction joints develop a pullout resistance equal to a minimum of 3/4 of the yield strength of the steel after 7 days. Test 15 bars using ASTM E488, except that alternate approved equipment may be used. All 15 tested bars must meet the required pullout strength. Perform corrective measures to provide equivalent pullout resistance if any of the test results do not meet the required minimum pullout strength. Repair damage from testing. Acceptable corrective measures include but are not limited to installation of additional or longer tie bars.
- 4.3.1. **Manual Placement.** Secure reinforcing bars at alternate intersections with wire ties or locking support chairs. Tie all splices with wire.
- 4.3.2. **Mechanical Placement.** Complete the work using manual placement methods described above if mechanical placement of reinforcement results in steel misalignment or improper location, poor concrete consolidation, or other inadequacies.
- 4.4. **Joints.** Install joints as shown on the plans. Joint sealants are not required on concrete pavement that is to be overlaid with asphaltic materials. Clean and seal joints in accordance with Item 438, "Cleaning and Sealing Joints." Repair excessive spalling of the joint saw groove using an approved method before installing the sealant. Seal all joints before opening the pavement to all traffic. Install a rigid transverse bulkhead, for the reinforcing steel, and shaped accurately to the cross-section of the pavement when placing of concrete is stopped.
- 4.4.1. **Placing Reinforcement at Joints.** Complete and place the assembly of parts at pavement joints at the required location and elevation, with all parts rigidly secured in the required position, when shown on the plans.
- 4.4.2. **Transverse Construction Joints.**
- 4.4.2.1. **Continuously Reinforced Concrete Pavement (CRCP).** Install additional longitudinal reinforcement through the bulkhead when shown on the plans. Protect the reinforcing steel immediately beyond the construction joint from damage, vibration, and impact.
- 4.4.2.2. **Concrete Pavement Contraction Design (CPCD).** Install and rigidly secure a complete joint assembly and bulkhead in the planned transverse contraction joint location when the placing of concrete is intentionally stopped. Install a transverse construction joint either at a planned transverse contraction joint location or mid-slab between planned transverse contraction joints when the placing of concrete is unintentionally stopped. Install tie bars of the size and spacing used in the longitudinal joints for mid-slab construction joints.
- 4.4.2.3. **Curb Joints.** Provide joints in the curb of the same type and location as the adjacent pavement. Use expansion joint material of the same thickness, type, and quality required for the pavement and of the section shown for the curb. Extend expansion joints through the curb. Construct curb joints at all transverse pavement joints. Place reinforcing steel into the plastic concrete pavement for non-monolithic curbs as shown on the plans unless otherwise approved. Form or saw the weakened plane joint across the full width

of concrete pavement and through the monolithic curbs. Construct curb joints in accordance with Item 529, "Concrete Curb, Gutter, and Combined Curb and Gutter."

- 4.5. **Placing and Removing Forms.** Use clean and oiled forms. Secure forms on a base or firm subgrade that is accurately graded and that provides stable support without deflection and movement by form riding equipment. Pin every form at least at the middle and near each end. Tightly join and key form sections together to prevent relative displacement.

Set side forms far enough in advance of concrete placement to permit inspection. Check conformity of the grade, alignment, and stability of forms immediately before placing concrete, and make all necessary corrections. Use a straightedge or other approved method to test the top of forms to ensure that the ride quality requirements for the completed pavement will be met. Stop paving operations if forms settle or deflect more than 1/8 in. under finishing operations. Reset forms to line and grade, and refinish the concrete surface to correct grade.

Avoid damage to the edge of the pavement when removing forms. Repair damage resulting from form removal and honeycombed areas with a mortar mix within 24 hr. after form removal unless otherwise approved. Clean joint face and repair honeycombed or damaged areas within 24 hr. after a bulkhead for a transverse construction joint has been removed unless otherwise approved. Promptly apply membrane curing compound to the edge of the concrete pavement when forms are removed before 72 hr. after concrete placement.

Forms that are not the same depth as the pavement, but are within 2 in. of that depth are permitted if the subbase is trenched or the full width and length of the form base is supported with a firm material to produce the required pavement thickness. Promptly repair the form trench after use. Use flexible or curved wood or metal forms for curves of 100-ft. radius or less.

- 4.6. **Concrete Delivery.** Clean delivery equipment as necessary to prevent accumulation of old concrete before loading fresh concrete. Use agitated delivery equipment for concrete designed to have a slump of more than 5 in. Segregated concrete is subject to rejection.

Begin the discharge of concrete delivered in agitated delivery equipment conforming to the requirements of Item 421, "Hydraulic Cement Concrete." Place non-agitated concrete within 45 min. after batching. Reduce times as directed when hot weather or other conditions cause quick setting of the concrete.

- 4.7. **Concrete Placement.** Do not allow the pavement edge to deviate from the established paving line by more than 1/2 in. at any point. Place the concrete as near as possible to its final location, and minimize segregation and rehandling. Distribute concrete using shovels where hand spreading is necessary. Do not use rakes or vibrators to distribute concrete.

- 4.7.1. **Consolidation.** Consolidate all concrete by approved mechanical vibrators operated on the front of the paving equipment. Use immersion-type vibrators that simultaneously consolidate the full width of the placement when machine finishing. Keep vibrators from dislodging reinforcement. Use hand-operated vibrators to consolidate concrete along forms, at all joints and in areas not accessible to the machine-mounted vibrators. Do not operate machine-mounted vibrators while the paving equipment is stationary. Vibrator operations are subject to review.

- 4.7.2. **Curbs.** Conform to the requirements of Item 529, "Concrete Curb, Gutter, and Combined Curb and Gutter" where curbs are placed separately.

- 4.7.3. **Temperature Restrictions.** Place concrete that is between 40°F and 95°F when measured in accordance with Tex-422-A at the time of discharge, except that concrete may be used if it was already in transit when the temperature was found to exceed the allowable maximum. Take immediate corrective action or cease concrete production when the concrete temperature exceeds 95°F.

Do not place concrete when the ambient temperature in the shade is below 40°F and falling unless approved. Concrete may be placed when the ambient temperature in the shade is above 35°F and rising or

above 40°F. Protect the pavement with an approved insulating material capable of protecting the concrete for the specified curing period when temperatures warrant protection against freezing. Submit for approval proposed measures to protect the concrete from anticipated freezing weather for the first 72 hr. after placement. Repair or replace all concrete damaged by freezing.

- 4.8. **Spreading and Finishing.** Finish all concrete pavement with approved self-propelled equipment. Use power-driven spreaders, power-driven vibrators, power-driven strike-off, screed, or approved alternate equipment. Use the transverse finishing equipment to compact and strike-off the concrete to the required section and grade without surface voids. Use float equipment for final finishing. Use concrete with a consistency that allows completion of all finishing operations without addition of water to the surface. Use the minimal amount of water fog mist necessary to maintain a moist surface. Reduce fogging if float or straightedge operations result in excess slurry.
- 4.8.1. **Finished Surface.** Perform sufficient checks with long-handled 10-ft. and 15-ft. straightedges on the plastic concrete to ensure the final surface is within the tolerances specified in Surface Test A in Item 585, "Ride Quality for Pavement Surfaces." Check with the straightedge parallel to the centerline.
- 4.8.2. **Maintenance of Surface Moisture.** Prevent surface drying of the pavement before application of the curing system by means that may include water fogging, the use of wind screens, and the use of evaporation retardants. Apply evaporation retardant at the manufacturer's recommended rate. Reapply the evaporation retardant as needed to maintain the concrete surface in a moist condition until curing system is applied. Do not use evaporation retardant as a finishing aid. Failure to take acceptable precautions to prevent surface drying of the pavement will be cause for shutdown of pavement operations.
- 4.8.3. **Surface Texturing.** Complete final texturing before the concrete has attained its initial set. Drag the carpet longitudinally along the pavement surface with the carpet contact surface area adjusted to provide a satisfactory coarsely textured surface. Prevent the carpet from getting plugged with grout. Do not perform carpet dragging operations while there is excessive bleed water.

A metal-tine texture finish is required unless otherwise shown on the plans. Provide transverse tining unless otherwise shown on the plans. Immediately following the carpet drag, apply a single coat of evaporation retardant, if needed, at the rate recommended by the manufacturer. Provide the metal-tine finish immediately after the concrete surface has set enough for consistent tining. Operate the metal-tine device to obtain grooves approximately 3/16 in. deep, with a minimum depth of 1/8 in., and approximately 1/12 in. wide. Do not overlap a previously tined area. Use manual methods to achieve similar results on ramps, small or irregular areas, and narrow width sections of pavements. Repair damage to the edge of the slab and joints immediately after texturing. Do not tine pavement that will be overlaid or that is scheduled for blanket diamond grinding or shot blasting.

Target a carpet drag texture of 0.04 in., as measured by Tex-436-A, when carpet drag is the only surface texture required on the plans. Ensure adequate and consistent macro-texture is achieved by applying enough weight to the carpet and by keeping the carpet from getting plugged with grout. Correct any location with a texture less than 0.03 in. by diamond grinding or shot blasting. The Engineer will determine the test locations at points located transversely to the direction of traffic in the outside wheel path.

- 4.8.4. **Small, Irregular Area, or Narrow Width Placements.** Use hand equipment and procedures that produce a consolidated and finished pavement section to the line and grade where machine placements and finishing of concrete pavement are not practical.
- 4.8.5. **Emergency Procedures.** Use hand-operated equipment for applying texture, evaporation retardant, and cure in the event of equipment breakdown.
- 4.9. **Curing.** Keep the concrete pavement surface from drying as described in Section 360.4.8.2., "Maintenance of Surface Moisture," until the curing material has been applied. Maintain and promptly repair damage to curing materials on exposed surfaces of concrete pavement continuously for at least 3 curing days. A curing day is defined as a 24-hr. period when either the temperature taken in the shade away from artificial heat is above 50°F for at least 19 hr. or the surface temperature of the concrete is maintained above 40°F for 24 hr.

Curing begins when the concrete curing system has been applied. Stop concrete paving if curing compound is not being applied promptly and maintained adequately. Other methods of curing in accordance with Item 422, "Concrete Superstructures," may be used when specified or approved.

- 4.9.1. **Membrane Curing.** Spray the concrete surface uniformly with 2 coats of membrane curing compound at an individual application rate of no more than 180 sq. ft. per gallon. Apply the curing compound before allowing the concrete surface to dry.

Manage finishing and texturing operations to ensure placement of curing compound on a moist concrete surface, relatively free of bleed water, to prevent any plastic shrinkage cracking. Time the application of curing compound to prevent plastic shrinkage cracking.

Maintain curing compounds in a uniformly agitated condition, free of settlement before and during application. Do not thin or dilute the curing compound.

Apply additional compound at the same rate of coverage to correct damage where the coating shows discontinuities or other defects or if rain falls on the newly coated surface before the film has dried enough to resist damage. Ensure that the curing compound coats the sides of the tining grooves.

- 4.9.2. **Asphalt Curing.** Apply a uniform coating of asphalt curing at a rate of 90 to 180 sq. ft. per gallon when an asphaltic concrete overlay is required. Apply curing immediately after texturing and once the free moisture (sheen) has disappeared. Obtain approval to add water to the emulsion to improve spray distribution. Maintain the asphalt application rate when using diluted emulsions. Maintain the emulsion in a mixed condition during application.

- 4.9.3. **Curing Class HES Concrete.** Provide membrane curing in accordance with Section 360.4.9.1., "Membrane Curing," for all Class HES concrete pavement. Promptly follow by wet mat curing in accordance with Section 422.4.8., "Final Curing," until opening strength is achieved but not less than 24 hr.

- 4.9.4. **Curing Fast-Track Concrete Pavement.** Provide wet mat curing unless otherwise shown on the plans or as directed. Cure in accordance with Section 422.4.8., "Final Curing." Apply a Type 1-D or Type 2 membrane cure instead of wet mat curing if the air temperature is below 65°F and insulating blankets are used.

- 4.10. **Sawing Joints.** Saw joints to the depth shown on the plans as soon as sawing can be accomplished without damage to the pavement regardless of time of day or weather conditions. Some minor raveling of the saw-cut is acceptable. Use a chalk line, string line, sawing template, or other approved method to provide a true joint alignment. Provide enough saws to match the paving production rate to ensure sawing completion at the earliest possible time to avoid uncontrolled cracking. Reduce paving production if necessary to ensure timely sawing of joints. Promptly restore membrane cure damaged within the first 72 hr. of curing.

- 4.11. **Protection of Pavement and Opening to Traffic.** Testing for early opening is the responsibility of the Contractor regardless of job-control testing responsibilities unless otherwise shown on the plans or as directed. Testing result interpretation for opening to traffic is subject to approval.

- 4.11.1. **Protection of Pavement.** Erect and maintain barricades and other standard and approved devices that will exclude all vehicles and equipment from the newly placed pavement for the periods specified. Protect the pavement from damage due to crossings using approved methods before opening to traffic. Where a detour is not readily available or economically feasible, an occasional crossing of the roadway with overweight equipment may be permitted for relocating equipment only but not for hauling material. When an occasional crossing of overweight equipment is permitted, temporary matting or other approved methods may be required.

Maintain an adequate supply of sheeting or other material to cover and protect fresh concrete surface from weather damage. Apply as needed to protect the pavement surface from weather.

- 4.11.2. **Opening Pavement to All Traffic.** Pavement that is 7 days old may be opened to all traffic. Clean pavement, place stable material against the pavement edges, seal joints, and perform all other traffic safety related work before opening to traffic.
- 4.11.3. **Opening Pavement to Construction Equipment.** Unless otherwise shown on the plans, concrete pavement may be opened early to concrete paving equipment and related delivery equipment after the concrete is at least 48 hr. old and opening strength has been demonstrated in accordance with Section 360.4.11.4., “Early Opening to All Traffic,” before curing is complete. Keep delivery equipment at least 2 ft. from the edge of the concrete pavement. Keep tracks of the paving equipment at least 1 ft. from the pavement edge. Protect textured surfaces from the paving equipment. Restore damaged membrane curing as soon as possible. Repair pavement damaged by paving or delivery equipment before opening to all traffic.
- 4.11.4. **Early Opening to All Traffic.** Concrete pavement may be opened after curing is complete and the concrete has attained a flexural strength of 450 psi or a compressive strength of 3,200 psi, except that pavement using Class HES concrete may be opened after 24 hr. if the specified strength is achieved.
- 4.11.4.1. **Strength Testing.** Test concrete specimens cured under the same conditions as the portion of the pavement involved.
- 4.11.4.2. **Maturity Method.** Use the maturity method, Tex-426-A, to estimate concrete strength for early opening pavement to traffic unless otherwise shown on the plans. Install at least 2 maturity sensors for each day’s placement in areas where the maturity method will be used for early opening. Maturity sensors, when used, will be installed near the day’s final placement for areas being evaluated for early opening. Use test specimens to verify the strength–maturity relationship in accordance with Tex-426-A, starting with the first day’s placement corresponding to the early opening pavement section.
- Verify the strength–maturity relationship at least every 10 days of production after the first day. Establish a new strength–maturity relationship when the strength specimens deviate more than 10% from the maturity-estimated strengths. Suspend use of the maturity method for opening pavements to traffic when the strength–maturity relationship deviates by more than 10% until a new strength–maturity relationship is established.
- The Engineer will determine the frequency of verification when the maturity method is used intermittently or for only specific areas.
- 4.11.5. **Fast Track Concrete Pavement.** Open the pavement after the concrete has been cured for at least 8 hr. and attained a minimum compressive strength of 1,800 psi or a minimum flexural strength of 255 psi when tested in accordance with Section 360.4.11.4.1., “Strength Testing,” or Section 360.4.11.4.2., “Maturity Method,” unless otherwise directed. Cover the pavement with insulating blankets when the air temperature is below 65°F until the pavement is opened to traffic.
- 4.11.6. **Emergency Opening to Traffic.** Open the pavement to traffic under emergency conditions, when the pavement is at least 72 hr. old when directed in writing. Remove all obstructing materials, place stable material against the pavement edges, and perform other work involved in providing for the safety of traffic as required for emergency opening.
- 4.12. **Pavement Thickness.** The Engineer will check the thickness in accordance with Tex-423-A unless other methods are shown on the plans. The Engineer will perform 1 thickness test consisting of 1 reading at approximately the center of the paving equipment every 500 ft. or fraction thereof. Core where directed, in accordance with Tex-424-A, to verify deficiencies of more than 0.2 in. from plan thickness and to determine the limits of deficiencies of more than 0.75 in. from plan thickness. Fill core holes using an approved concrete mixture and method.
- 4.12.1. **Thickness Deficiencies Greater than 0.2 in.** Take one 4-in. diameter core at that location to verify the measurement when any depth test measured in accordance with Tex-423-A is deficient by more than 0.2 in. from the plan thickness.

Take 2 additional cores from the unit (as defined in Section 360.4.12.3., "Pavement Units for Payment Adjustment" at intervals of at least 150 ft. and at selected locations if the core is deficient by more than 0.2 in., but not by more than 0.75 in. from the plan thickness, and determine the thickness of the unit for payment purposes by averaging the length of the 3 cores. In calculations of the average thickness of this unit of pavement, measurements in excess of the specified thickness by more than 0.2 in. will be considered as the specified thickness plus 0.2 in.

4.12.2. **Thickness Deficiencies Greater than 0.75 in.** Take additional cores at 10-ft. intervals in each direction parallel to the centerline to determine the boundary of the deficient area if a core is deficient by more than 0.75 in. The Engineer will evaluate any area of pavement found deficient in thickness by more than 0.75 in., but not more than 1 in. Remove and replace the deficient areas without additional compensation or retain deficient areas without compensation, as directed. Remove and replace any area of pavement found deficient in thickness by more than 1 in. without additional compensation.

4.12.3. **Pavement Units for Payment Adjustment.** Limits for applying a payment adjustment for deficient pavement thickness from 0.20 in. to not more than 0.75 in. are 500 ft. of pavement in each lane. Lane width will be as shown on typical sections and pavement design standards.

For greater than 0.75 in. deficient thickness, the limits for applying zero payment or requiring removal will be defined by coring or equivalent nondestructive means as determined by the Engineer. The remaining portion of the unit determined to be less than 0.75 in. deficient will be subject to the payment adjustment based on the average core thickness at each end of the 10-ft. interval investigation as determined by the Engineer.

Shoulders will be measured for thickness unless otherwise shown on the plans. Shoulders 6 ft. wide or wider will be considered as lanes. Shoulders less than 6 ft. wide will be considered part of the adjacent lane.

Limits for applying payment adjustment for deficient pavement thickness for ramps, widenings, acceleration and deceleration lanes, and other miscellaneous areas are 500 ft. in length. Areas less than 500 ft. in length will be individually evaluated for payment adjustment based on the plan area.

4.13. **Ride Quality.** Measure ride quality in accordance with Item 585, "Ride Quality for Pavement Surfaces," unless otherwise shown on the plans.

5. MEASUREMENT

This Item will be measured as follows:

5.1. **Concrete Pavement.** Concrete pavement will be measured by the square yard of surface area in place. The surface area includes the portion of the pavement slab extending beneath the curb.

5.2. **Curb.** Curb on concrete pavement will be measured by the foot in place.

6. PAYMENT

These prices are full compensation for materials, equipment, labor, tools, and incidentals.

6.1. **Concrete Pavement.** The work performed and materials furnished in accordance with this Item and measured as provided under "Measurement" will be paid for at the adjusted unit price bid for "Concrete Pavement" of the type and depth specified as adjusted in accordance with Section 360.6.2., "Deficient Thickness Adjustment."

6.2. **Deficient Thickness Adjustment.** Where the average thickness of pavement is deficient in thickness by more than 0.2 in. but not more than 0.75 in., payment will be made using the adjustment factor as specified in Table 2 applied to the bid price for the deficient area for each unit as defined under Section 360.4.12.3., "Pavement Units for Payment Adjustment."

Table 2
Deficient Thickness Price Adjustment Factor

Deficiency in Thickness Determined by Cores (in.)	Proportional Part of Contract Price Allowed (Adjustment Factor)
Not deficient	1.00
Over 0.00 through 0.20	1.00
Over 0.20 through 0.30	0.80
Over 0.30 through 0.40	0.72
Over 0.40 through 0.50	0.68
Over 0.50 through 0.75	0.57

- 6.3. **Curb.** Work performed and furnished in accordance with this Item and measured as provided under "Measurement" will be paid for at the unit price bid for "Curb" of the type specified.

Item 361

Repair of Concrete Pavement



1. DESCRIPTION

Repair concrete pavement to half-depth or full-depth in accordance with the details shown on the plans and the requirements of this Item.

2. MATERIALS

Furnish materials in accordance with the following:

- Item 360, "Concrete Pavement,"
- Item 421, "Hydraulic Cement Concrete,"
- Item 440, "Reinforcement for Concrete,"
- DMS-6100, "Epoxyes and Adhesives," and
- DMS-4655, "Concrete Repair Materials."

- 2.1. **Half-Depth Repair.** Obtain approval for the repair material mix design. The selection of repair material should be based on the time for opening to traffic and temperature range during the repair.

Provide Class HES concrete in accordance with Item 421, "Hydraulic Cement Concrete," and designed to attain a minimum average flexural strength of 255 psi or a minimum average compressive strength of 1,800 psi within the timeframe designated for opening to traffic if it is less than 72 hr. after concrete placement. Otherwise, provide Class S conforming to Item 421, "Hydraulic Cement Concrete" or Class P concrete conforming to Item 360, "Concrete Pavement."

Provide material meeting the requirements of DMS-4655, "Concrete Repair Materials," Type A when Class HES concrete does not meet the strength requirement within the designated timeframe.

- 2.2. **Full-Depth Repair.** Obtain approval for the repair material mix design. The selection of repair material should be based on the time for opening to traffic and temperature range during the repair.

- 2.2.1. **Hydraulic Cement Concrete for Pavement.** Provide Class HES concrete designed to attain a minimum average flexural strength of 255 psi or a minimum average compressive strength of 1,800 psi within the designated timeframe if the timeframe designated for opening to traffic is less than 72 hr. after concrete placement. Otherwise, provide Class P concrete conforming to Item 360, "Concrete Pavement."

- 2.2.2. **Base Material.** Furnish cold-mix asphaltic materials for replacement base material when shown on the plans. The Engineer may waive quality control (QC) tests for base material.

- 2.2.3. **Asphalt Concrete.** Furnish asphalt concrete material for overlay and asphalt shoulder repair as shown on the plans. The Engineer may waive QC tests for this material.

3. EQUIPMENT

Provide tools and equipment necessary for proper execution of the work that meet the pertinent requirements of the following:

- Item 360, "Concrete Pavement"
- **Concrete Demolition Equipment.** Provide chipping hammers or hydro-demolition equipment for the bulk removal of concrete.

- **Concrete Lift-Out Equipment.** Provide steel chains, lift pins, and a crane or front-end loader capable of lifting the concrete and loading it onto a flatbed or dump truck.
- **Drill.** Use a maximum 40-lb. drill with tungsten carbide bits.
- **Air Compressor.** Provide compressor equipped with filters designed to remove oil from the air and capable of delivering air to remove dust and debris.

4. CONSTRUCTION

Submit for approval all materials and methods of application at least 2 weeks before beginning any repair work. Repair locations will be as indicated on the plans or as directed. Repair areas may be adjusted after removing distressed concrete. Switch the half-depth repair to the full-repair if exposed existing longitudinal bars are deficient, as approved. Compensation will be made for unexpected volumes of repair areas or changes in scope of work.

- 4.1. **Half-Depth Repair.** Repair locations will be as indicated on the plans or as directed. Repair boundaries should be square or rectangular with a minimum length and width of 12 in.

Saw-cut repair boundaries to a minimum depth of 1-1/2 in. Do not saw-cut longitudinal or transverse steel. If the longitudinal steel is cut, a full-depth repair may be required as directed without additional compensation.

Remove concrete from the repair area as designated. Start at the center of the repair area. Ensure all loose concrete materials are removed and only sound concrete is left in place. Increase the repair area and perform a full-depth repair as directed if longitudinal steel bars were damaged by the removal operations. No additional compensation will be made.

Clean the area to be repaired by approved methods. Remove all loose particles, dirt, deteriorated concrete, or other substances that would impair the bond of the repair material.

Mix, place, and cure in accordance with the manufacturer's recommendation when material in DMS-4655, "Concrete Repair Materials," is used. Mix, place, and cure concrete in accordance with Item 360, "Concrete Pavement," when Class S, Class P, or Class HES is used. Test Class S, Class P, and Class HES concrete to the requirements of Section 360.4.2., "Job-Control Testing."

Match the grade and alignment of existing concrete pavement unless otherwise shown on the plans. Concrete pavement may be opened to traffic when specified strength is achieved.

- 4.2. **Full-Depth Repair.** Repair areas identified by the Engineer. Make repair areas rectangular, at least 6 ft. long and at least 1/2 a full lane in width unless otherwise shown on the plans. Accept ownership of all removed material, and dispose of it in accordance with federal, state, and local regulations unless otherwise shown on the plans. Saw-cut and remove existing asphalt concrete overlay at least 2 ft. longer than the repair patch in each longitudinal direction when there is existing asphalt concrete overlay over the repair area.

Saw-cut the full depth through the concrete around the perimeter of the repair area before removal. Schedule work so that concrete placement follows full-depth saw-cutting by no more than 7 days unless otherwise shown on the plans or approved.

Remove the slab by lifting the slab with a minimum disturbance to the base materials and surrounding concrete. Do not spall or fracture concrete adjacent to the repair area. Saw-cut and remove additional concrete as directed, after slab removal, if distresses are found in the surrounding concrete pavement. Repair damages to concrete pavement caused by the Contractor's operation without additional compensation. Perform repairs as directed.

Remove loose or damaged base material completely, leaving no loose base material.

Recompact base materials to the satisfaction of the Engineer. Level the base layer with cold-mix asphalt to the original bottom line and grade of the concrete slab before repair concrete is placed when shown on the plans. Place concrete directly onto the compacted base layer unless otherwise directed.

Use tie bars to restore the continuity of the concrete pavement. Demonstrate, through simulated job conditions, that the bond strength of the epoxy-grouted tie bars meets a pullout strength of at least 3/4 of the yield strength of the tie bar when tested in accordance with ASTM E488 within the epoxy manufacturer's recommended curing time. Increase embedment depth and retest when necessary to meet testing requirements. Perform tie bar testing before starting repair work.

Place tie bars as shown on the plans. Drill holes into the existing concrete at least 10 in. deep unless otherwise directed. Use a drill bit with a diameter that is 1/8 in. greater than that of tie bars. Clean the holes with a wire brush and compressed air to remove all the dust and moisture. Follow the epoxy manufacturer's instructions to apply the epoxy. Insert the tip of the epoxy cartridge or the tip of the machine applicator to the end of the tie bar hole, and inject Type III, Class C epoxy to fill the entire hole. Insert tie bars.

Place new deformed reinforcing steel bars of the same size and spacing as shown on the plans for Continuously Reinforced Concrete Pavement (CRCP) repairs. Lap all longitudinal reinforcing steel at least 25 in. Provide and place approved supports to firmly hold the new reinforcing steel in place when needed.

Place dowel bars as shown on the plans for Concrete Pavement Contraction Design (CPCD) repairs. Provide and place approved supports to firmly hold the dowel bars in place.

Mix, place, cure, and test concrete to the requirements of Item 360, "Concrete Pavement," and Item 421, "Hydraulic Cement Concrete." Broom-finish the concrete surface unless otherwise shown on the plans.

Perform a timely saw-cut over the dowel bars and restore the transverse contraction joint for CPCD. Restore the existing longitudinal joints to the requirements of Section 360.4.4., "Joints."

Match the grade and alignment of existing concrete pavement. Replace any asphalt overlay and shoulder material removed with new asphalt concrete material after concrete strength requirements have been met.

Remove repair area debris from the right of way each day. Concrete pavement may be opened to traffic when specified strength is achieved.

5. MEASUREMENT

This Item will be measured by the square yard in place of the completed concrete surface area repaired.

6. PAYMENT

The work performed and the materials furnished in accordance with this Item and measured as specified under "Measurement" will be paid for at the unit price bids for "Repair of Concrete Pavement (Half-Depth)" and "Repair of Concrete Pavement (Full-Depth)." This price is full compensation for removal, stockpiling, and disposal of waste material and for equipment, materials, labor, tools, and incidentals. Asphalt concrete, base material, and curbing will not be paid for directly but will be considered subsidiary to this Item.

400 Items

Structures

This page intentionally left blank

Item 400

Excavation and Backfill for Structures



1. DESCRIPTION

Excavate for placement and construction of structures and backfill structures. Cut and restore pavement.

2. MATERIALS

Use materials that meet the requirements of the following Items.

- Item 401, "Flowable Backfill,"
- Item 421, "Hydraulic Cement Concrete," and
- DMS-4600, "Hydraulic Cement."

3. CONSTRUCTION

3.1. Excavation.

- 3.1.1. **General.** Excavate to the lines and grades shown on the plans or as directed. Provide slopes, benching, sheeting, bracing, pumping, and bailing as necessary to maintain the stability and safety of excavations up to 5 ft. deep. Excavation protection for excavations deeper than 5 ft. are governed by Item 402, "Trench Excavation Protection," and Item 403, "Temporary Special Shoring." Use satisfactory excavated material as backfill or as embankment fill in accordance with Item 132, "Embankment." Dispose of material not incorporated into the final project off the right of way in accordance with federal, state, and local regulations.

Keep any topsoil that has been removed separate, and replace it, as nearly as feasible, in its original position when excavating for installation of structures across private property or beyond the limits of the embankment. Restore the area to an acceptable condition.

Excavate drilled shafts in accordance with Item 416, "Drilled Shaft Foundations."

- 3.1.1.1. **Obstructions.** Remove obstructions to the proposed construction, including trees and other vegetation, debris, and structures, over the width of the excavation to a depth of 1 ft. below the bottom of excavation. Remove as required to clear the new structure and plug in an approved manner if abandoned storm drains, sewers, or other drainage systems are encountered. Restore the bottom of the excavation to grade by backfilling after removing obstructions in accordance with this Item. Dispose of surplus materials in accordance with federal, state, and local regulations.

- 3.1.1.2. **Excavation in Streets.** Cut pavement and base to neat lines when structures are installed in streets, highways, or other paved areas. Restore pavement structure after completion of excavation and backfilling.

Maintain and control traffic in accordance with the approved traffic control plan and the TMUTCD.

- 3.1.1.3. **Utilities.** Comply with the requirements of Article 7.15., "Responsibility for Damage Claims." Conduct work with minimum disturbance of existing utilities, and coordinate work in or near utilities with the utility owners. Inform utility owners before work begins, allowing them enough time to identify, locate, reroute, or make other adjustments to utility lines.

Avoid cutting or damaging underground utility lines that are to remain in place. Promptly notify the utility company if damage occurs. Provide temporary flumes across the excavation while open if an active sanitary

sewer line is damaged during excavation, and restore the lines when backfilling has progressed to the original bedding lines of the cut sewer.

- 3.1.1.4. **De-Watering.** Construct or place structures in the presence of water only if approved. Place precast members, pipe, and concrete only on a dry, firm surface. Remove water by bailing, pumping, well-point installation, deep wells, underdrains, or other approved method.

Remove standing water in a manner that does not allow water movement through or alongside concrete being placed if structures are approved for placement in the presence of water. Pump or bail only from a suitable sump separated from the concrete work while placing structural concrete or for a period of at least 36 hr. thereafter. Pump or bail during placement of seal concrete only to the extent necessary to maintain a static head of water within the cofferdam. Pump or bail to de-water inside a sealed cofferdam only after the seal has aged at least 36 hr.

Place a stabilizing material in the bottom of the excavation if the bottom of an excavation cannot be de-watered to the point the subgrade is free of mud or it is difficult to keep reinforcing steel clean. Use flexible base, cement-stabilized base or backfill, lean concrete, or other approved stabilizing material. Provide concrete with at least 275 lb. of cement per cubic yard, if lean concrete is used, and place to a minimum depth of 3 in. Stabilizing material placed for the convenience of the Contractor will be at the Contractor's expense.

- 3.1.2. **Bridge Foundations and Retaining Walls.** Do not disturb material below the bottom of footing grade. Do not backfill to compensate for excavation that has extended below grade. Fill the area with concrete at the time the footing is placed if excavation occurs below the proposed footing grade. Additional concrete placed will be at the Contractor's expense.

Take core samples to determine the character of the supporting materials if requested. Provide an intact sample adequate to judge the character of the founding material. Take these cores when the excavation is close to completion. Cores should be approximately 5 ft. deeper than the proposed founding grade.

Remove loose material if the founding stratum is rock or another hard material, and clean and cut it to a firm surface that is level, stepped, or serrated, as directed. Clean out soft seams, and fill with concrete at the time the footing is placed.

Place the foundation once the Engineer has inspected the excavation and authorized changes have been made to provide a uniform bearing condition if the material at the footing grade of a retaining wall, bridge bent, or pier is a mixture of compressible and incompressible material.

- 3.1.3. **Cofferdams.** The term "cofferdam" designates any temporary or removable structure constructed to hold surrounding earth, water, or both out of the excavation whether the structure is formed of soil, timber, steel, concrete, or a combination of these. Use pumping wells or well points for de-watering cofferdams if required.

Submit details and design calculations for sheet-pile or other types of cofferdams requiring structural members bearing the seal of a licensed professional engineer for review before constructing the cofferdam. The Department reserves the right to reject designs. Design structural systems to comply with the AASHTO *Standard Specifications for Highway Bridges* or AASHTO LRFD *Bridge Design Specifications*. Interior dimensions of cofferdams must provide enough clearance for the construction, inspection, and removal of required forms and, if necessary, enough room to allow pumping outside the forms. Extend sheet-pile cofferdams well below the bottom of the footings, and make concrete seals as well braced and watertight as practicable.

Use Class E concrete for foundation seals unless otherwise specified. Place concrete foundation seals in accordance with Item 420, "Concrete Substructures." Seals placed for the convenience of the Contractor will be at the Contractor's expense.

Make the excavation deep enough to allow for swelling of the material at the base of the excavation during pile-driving operations when the Engineer judges it to be impractical to de-water inside a cofferdam and a

concrete seal is to be placed around piling driven within the cofferdam. Remove swelling material to the bottom of the seal grade after driving the piling. Remove the foundation material to exact footing grades where it is possible to de-water inside the cofferdam without placing a seal after driving piling. Do not backfill a foundation to compensate for excavation that has been extended below grade; fill such areas below grade with concrete at the time the seals or footings are placed.

Remove cofferdams after completing the substructure without disturbing or damaging the structure unless otherwise provided.

- 3.1.4. **Culverts and Storm Drains.** When the design requires special bedding conditions for culverts or storm drains, an excavation diagram will be shown on the plans. Do not exceed these limits of excavation.

Construct pipe structures in an open cut with vertical sides extending to a point 1 ft. above the pipe unless otherwise shown on the plans. When site conditions or the plans do not prohibit sloping the cut, the excavation may be stepped or laid back to a stable slope beginning 1 ft. above the pipe. Maintain the stability of the excavation throughout the construction period.

Construct the embankment for pipe to be installed in fill above natural ground to an elevation at least 1 ft. above the top of the pipe, and then excavate for the pipe.

- 3.1.4.1. **Unstable Material.** Remove the material to a depth of no more than 2 ft. below the grade of the structure when unstable soil is encountered at established footing grade, unless the Engineer authorizes additional depth. Replace soil removed with stable material in uniform layers no greater than 8 in. deep (loose measurement). Each layer must have enough moisture to be compacted by rolling or tamping as required to provide a stable foundation for the structure.

Use special materials such as flexible base, cement-stabilized base, cement-stabilized backfill, or other approved material when it is not feasible to construct a stable foundation as outlined above.

- 3.1.4.2. **Incompressible Material.** Remove the incompressible material to 6 in. below the footing grade, backfill with an approved compressible material, and compact in accordance with Section 400.3.3., "Backfill," if rock, part rock, or other incompressible material is encountered at established footing grade while placing prefabricated elements.

- 3.2. **Shaping and Bedding.** Place at least 2 in. of fine granular material for precast box sections on the base of the excavation before placing the box sections. Use bedding as shown in Figure 1 for pipe installations. Use Class C bedding unless otherwise shown on the plans. The Engineer may require the use of a template to secure reasonably accurate shaping of the foundation material. Undercut the excavation at least 4 in. where cement-stabilized backfill is indicated on the plans and backfill with stabilized material to support the pipe or box at the required grade.

B_c - Outside diameter or horizontal dimension
 D - Inside diameter of pipe
 d - Min. bedding material below pipe

D	d
≤ 27"	3"
30" to 60"	4"
≥ 66"	6"

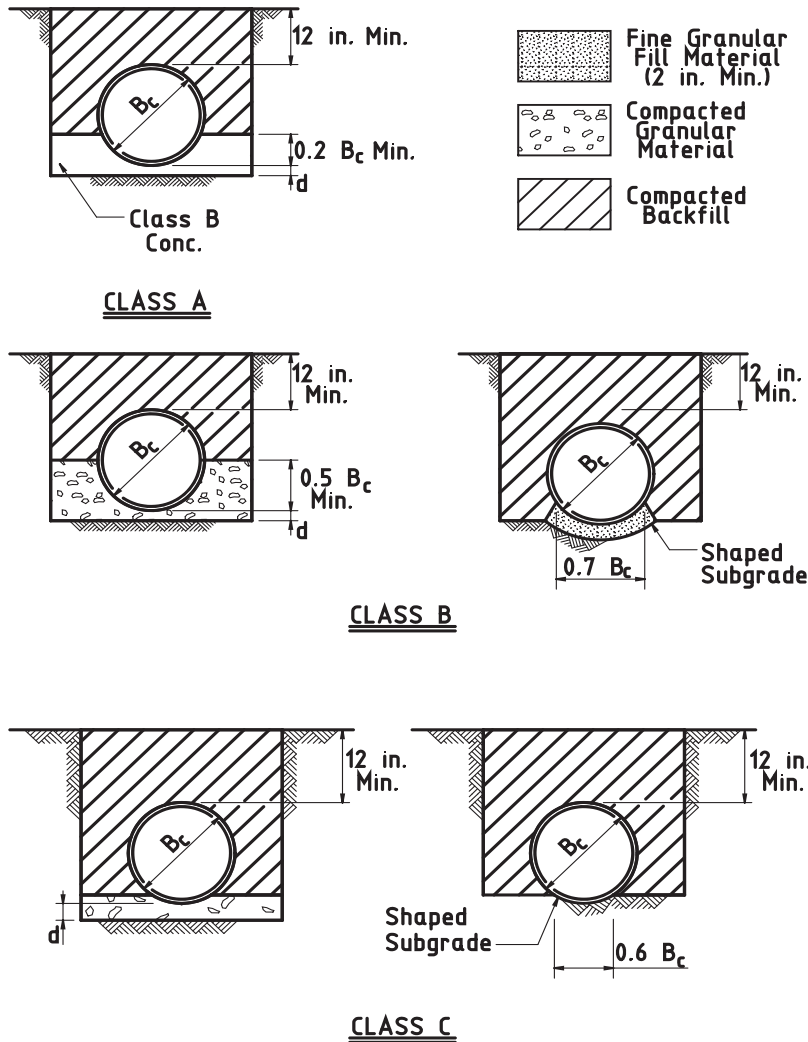

Figure 1
 Bedding Diagrams

3.3. **Backfill.**

3.3.1. **General.** Backfill the excavation after placement of the permanent structure as soon as practical. Use backfill free from stones large enough to interfere with compaction; large or frozen lumps that will not break down readily under compaction; and wood or other extraneous material. Obtain backfill material from excavation or from other sources.

Place backfill in layers no greater than 10 in. deep (loose measurement) in areas not supporting a completed roadbed, retaining wall, or embankment. Place backfill in uniform layers no greater than 8 in. deep (loose measurement) in areas supporting a portion of a roadbed, retaining wall, or embankment. Compact each layer to meet the density requirements of the roadbed, retaining wall, embankment material, or as shown on the plans.

Bring each layer of backfill material to the moisture content needed to obtain the required density. Use mechanical tamps or rammers to compact the backfill. Rollers may be used to compact backfill if feasible.

Cohesionless materials may be used for backfilling. Use cohesionless materials that conform to the requirements of Table 1.

Table 1
Cohesionless Material Gradation Limits

Sieve Size	Percent Retained
3"	0
#10	See Note ¹
#200	90-100

- No. 10 sieve requirements are 0 to 30% retained when used as aggregate for cement-stabilized backfill.

Compact cohesionless materials using vibratory equipment, water-ponding, or a combination of both.

- 3.3.2. **Bridge Foundations, Retaining Walls, Manholes/Inlets, and Box Culverts.** Place backfill against the structure only after the concrete has reached the design strength required in Item 421, "Hydraulic Cement Concrete."

Backfill retaining walls with material meeting the requirements of Item 423, "Retaining Walls." Backfill around bridge foundations, manholes/inlets and culverts using material with particles no more than 4 in. in greatest dimension and a gradation that permits thorough compaction. Use rock or gravel mixed with soil if the percentage of fines is enough to fill all voids and ensure a uniform and thoroughly compacted mass of proper density.

Use mechanical tamps and rammers to avoid damage to the structure where backfill material is being placed too close to the structure to permit compaction with blading and rolling equipment.

Avoid wedging action of backfill against structures. Step or serrate slopes bounding the excavation to prevent such action. Place backfill uniformly around bridge foundations. Place backfill equally and in uniform layers along both sides of manholes/inlets and culverts.

The Engineer may require backfilling of structures excavated into hard, erosion-resistant material, and subject to erosive forces, with stone or lean concrete.

Box culverts may be opened to traffic as soon as enough backfill and embankment has been placed over the top to protect culverts against damage from heavy construction equipment. Repair damage to culvert caused by construction traffic at no additional expense to the Department.

- 3.3.3. **Pipe.** Bring backfill material to the proper moisture condition after installing bedding and pipe as required and place it equally along both sides of the pipe in uniform layers no greater than 8 in. deep (loose measurement). Compact each lift mechanically. Thoroughly compact materials placed under the haunches of the pipe to prevent damage or displacement of the pipe. Place backfill in this manner to the top-of-pipe elevation. Place and compact backfill above the top of the pipe in accordance with Section 400.3.3.1., "General."

The Engineer may reject backfill material containing more than 20% by weight of material retained on a 3 in. sieve with large lumps not easily broken down or that cannot be spread in loose layers. Material excavated by a trenching machine will generally meet the requirements of this Section as long as large stones are not present.

Place and compact additional material where pipe extends beyond the toe of slope of the embankment and the depth of cover provided by backfill to the original ground level is less than the minimum required by the specifications for the type of pipe involved until the minimum cover has been provided.

- 3.3.4. **Cement-Stabilized Backfill.** Backfill the excavation to the elevations shown with cement-stabilized backfill when shown on the plans. Use cement-stabilized backfill that contains aggregate conforming to the gradation limits shown in Table 1, water, and a minimum of 7% hydraulic cement based on the dry weight of the aggregate, in accordance with Tex-120-E.

Place cement-stabilized backfill equally along the sides of structures to prevent strain on or displacement of the structure. Fill voids when placing cement-stabilized backfill. Use hand-operated tampers if necessary to fill voids.

- 3.3.5. **Flowable Backfill.** Backfill the excavation with flowable backfill to the elevations indicated when shown on the plans. Prevent the structure from being displaced during the placement of the flowable fill, and prevent flowable fill from entering manholes/inlets and culverts, and drainage structures.

4. MEASUREMENT

This is a plans quantity measurement item. The quantity to be paid is the quantity shown in the proposal, unless modified by Article 9.2., "Plans Quantity Measurement." Additional measurements or calculations will be made if adjustments of quantities are required.

- 4.1. **Structural Excavation.** Unless shown on the plans as a pay item, structural excavation quantities shown are for information purposes only.

When structural excavation is specified as a pay item, structural excavation for pipe headwalls, inlets, manholes, culvert or storm drain extensions less than 15 ft. long, bridge abutments, retaining walls, and side road and private entrance pipe culverts will not be measured. No allowance will be made for variance from plans quantity incurred by an alternate bid.

When specified as a pay item, structural excavation will be measured by the cubic yard as computed by the average end areas method. Excavation diagrams on the plans take precedence over the provisions of this Article.

- 4.1.1. **Boundaries of Measurement.**

- 4.1.1.1. **Pipe.**

- 4.1.1.1.1. **Pipe up to 42 Inches.** For pipe up to 42 in. nominal or equivalent diameter, no material outside of vertical planes 1 ft. beyond and parallel to the horizontal projection of the outside surfaces of the pipe will be included.

- 4.1.1.1.2. **Pipe Larger than 42 Inches.** For pipes larger than 42 in. nominal or equivalent diameter, no material outside of vertical planes located 2 ft. beyond and parallel to the horizontal projection of the outside surfaces of the pipe will be included.

Quantities for excavation in fill above natural ground include 1 ft. above the top of the pipe regardless of the height of completed fill. Excavation for pipe will be measured between the extreme ends of the completed structure including end appurtenances as shown on the plans and from centerline to centerline of inlets, manholes, etc.

- 4.1.1.2. **Structural Plate Structures.** No material outside of vertical planes 3 ft. beyond and parallel to the horizontal projection of the outside surfaces of the structure will be included. When the quality of the existing soil or embankment is less than that of the proposed backfill material, the limits of measurement will be extended to vertical planes located 1/2 of the span beyond the horizontal projection of the outside surfaces of the structure.

- 4.1.1.3. **Footings, Walls, Boxes, and Other Excavation.** No material outside of vertical planes 1 ft. beyond and parallel to the edges of the footings or outside walls will be included whether or not a cofferdam or shoring is

used. When plans provide the option of cast-in-place or precast boxes, measurement will be based on the cast-in-place option.

Where excavation in addition to that allowed for the footings is required for other portions of the structure, measurement for the additional excavation will be limited laterally by vertical planes 1 ft. beyond the face of the member and parallel to it, and vertically to a depth of 1 ft. below the bottom of the member.

- 4.1.1.4. **Excavation near Roadways and Channels.** At structure sites other than culverts and pipe excavations, the measurement of structural excavation will include only material below or outside the limits of the completed road or channel excavation. Roadway and channel excavation will be paid under Item 110, "Excavation." For culverts except side road and private entrance culverts, excavation within the limits of the structure and below or outside the limits of the completed roadway excavation will be measured as structural excavation.
- 4.1.2. **Falsework.** No measurement will be made for excavation necessary for placing forms or falsework that exceeds the limits given in Section 400.4.1.1., "Boundaries of Measurement."
- 4.1.3. **Swelling.** Measurement will not include materials removed below footing grades to compensate for anticipated swelling due to pile-driving, nor will it include material required to be removed due to swelling beyond the specified limits during pile-driving operations.
- 4.1.4. **Cave-Ins.** Measurement will not include additional volume caused by slips, slides, cave-ins, silting, or fill material resulting from the action of the elements or the Contractor's operation.
- 4.1.5. **Undercut.** Where rock or other incompressible or unstable material is undercut to provide a suitable foundation for pipe or box sections, such material below grade directed to be removed will be measured for payment.
- 4.1.6. **Grade Change.** Additional measurement will be made of the volume of excavation involved in the lowering or raising of the elevation of a footing, foundation, or structure unit, when such grade change is authorized.
- 4.2. **Cement-Stabilized Backfill.** Cement-stabilized backfill will be measured by the cubic yard as shown on the plans.
- 4.3. **Cutting and Restoring Pavement.** Cutting and restoring pavement will be measured by the square yard as shown on the plans. Excavation below pavement or base will be measured as structural excavation of the pertinent type.

5. PAYMENT

- 5.1. **Structural Excavation.** Unless specified as a pay item, structural excavation and backfill performed, and material furnished in accordance with this Item will not be paid for directly but are subsidiary to pertinent Items.

When structural excavation is specified as a pay item, the excavation and backfill work performed, and materials furnished will be paid for at the unit price bid for "Structural Excavation," "Structural Excavation (Box)," "Structural Excavation (Pipe)," and "Structural Excavation (Bridge)." This price includes concrete to compensate for excavation that has extended below grade for bridge foundations and retaining walls, and backfilling and compacting areas that were removed as part of structural excavation.

Cofferdams or other measures necessary for supporting excavations less than 5 ft. deep will not be measured or paid for directly but will be subsidiary to the Contract.

Foundation seal concrete for cofferdams, when required, will be paid for as provided in the pertinent Items. If no direct method of payment is provided in the Contract, the work will be measured and paid for in accordance with Article 9.7., "Payment for Extra Work and Force Account Method." Seal placed for the convenience of the Contractor will not be paid for.

Unless otherwise provided, stone or lean concrete backfill around structures as provided for in Section 400.3.3.2., "Bridge Foundations, Retaining Walls, Manholes/Inlets, and Box Culverts," will be measured and paid for as extra work in accordance with Article 9.7., "Payment for Extra Work and Force Account Method."

When structural excavation is specified as a pay item, a partial payment of 50% of the bid price will be made for structural excavation completed to the satisfaction of the Engineer but not backfilled. The remaining amount will be paid upon completion of backfilling. When the Contractor elects to excavate beyond plan requirements, no measurement will be made of the additional volume.

- 5.2. **Removal and Replacement of Unsuitable or Incompressible Material.** Removal and replacement of material will be paid for if directed. Removal and replacement of material or placement of special material made necessary by the softening of founding material due to the Contractor's sequence of work or operation, will be at the Contractor's expense. Special material used or additional excavation made for the Contractor's convenience will not be paid for.

- 5.2.1. **Structural Excavation as a Pay Item.** Where special materials are not required or specified, payment for the removal and replacement of unstable or incompressible material will be made at a price equal to 200% of the unit price bid per cubic yard for Structural Excavation. When the Contractor elects to remove and replace material deeper than directed, no measurement will be made on that portion below the directed elevation. This price is full compensation for removing the unstable or incompressible material; furnishing, hauling, placing, and compacting suitable replacement material; and equipment, labor, tools, and incidentals.

When the plans specify or when directed, the use of special materials such as flexible base, cement-stabilized base, cement-stabilized backfill, or other special material, payment for excavation below footing grades will be made at the unit price bid for Structural Excavation. Payment for furnishing, hauling, placing, and compacting the flexible base, cement-stabilized base, cement-stabilized backfill, or other special materials will be made at the unit price bid for these items in the Contract, or, if the required material is not a bid item, in accordance with Article 9.7., "Payment for Extra Work and Force Account Method."

- 5.2.2. **Structural Excavation Not a Pay Item.** Where special materials for backfill are not required or specified, payment for the authorized removal and replacement of unstable or incompressible material will be measured and paid for at \$15 per cubic yard of material removed. This price is full compensation for removing the unstable or incompressible material; furnishing, hauling, placing, and compacting suitable replacement material; and equipment, labor, tools, and incidentals.

When the plans specify or when directed, the use of special materials such as flexible base, cement-stabilized base, cement-stabilized backfill, or other special material, excavation below the footing grades will be paid for at \$10 per cubic yard. Payment for furnishing, hauling, placing, and compacting the flexible base, cement-stabilized base, cement-stabilized backfill, or other special materials will be made at the unit price bid for these items, or, if the required material is not a bid item, in accordance with Article 9.7., "Payment for Extra Work and Force Account Method."

- 5.3. **Lowering of a Structure Foundation.** If the Engineer requires a structure foundation to be lowered to an elevation below the grade shown on the plans, overexcavation will be paid in accordance with Table 2.

Table 2
Payment for Required Overexcavation

Variance of Revised Footing Grade from Plan Grade	Payment Terms	Variance of Revised Footing Grade from Plan Grade
	"Structural Excavation" is a Bid Item	"Structural Excavation" is not a Bid Item
Up to and including 5 ft.	Unit price equal to 115% of unit price bid for "Structural Excavation"	\$10 per cubic yard
Over 5 ft. up to 10 ft.	Unit price equal to 125% of unit price bid for "Structural Excavation"	\$12 per cubic yard
Over 10 ft.	In accordance with Article 9.7., "Payment for Extra Work and Force Account Method."	

- 5.4. **Cement-Stabilized Backfill.** Cement-stabilized backfill will be paid for at the unit price bid for "Cement-Stabilized Backfill."
- 5.5. **Cutting and Restoring Pavement.** Cutting and restoring pavement will be paid for at the unit price bid for "Cutting and Restoring Pavement" of the type specified.

Work done to repair damage to base or pavement incurred outside the limits shown on the plans, or the limits authorized, will not be measured for payment.

The unit prices bid are full compensation for excavation including removing obstructions and plugging drainage systems; bedding and backfilling including placing, sprinkling and compaction of material; soundings; cleaning and filling seams; constructing and removing cofferdams; de-watering, sheeting, or bracing excavations up to and including 5 ft. deep; pumps; drills; explosives; disposition of surplus material; cutting pavement and base to neat lines; and materials, hauling, equipment, labor, tools, and incidentals.

Flowable backfill will be paid for as provided in Item 401, "Flowable Backfill." Protection methods for open excavations deeper than 5 ft. will be measured and paid for as required under Item 402, "Trench Excavation Protection," or Item 403, "Temporary Special Shoring."

Item 401

Flowable Backfill



1. DESCRIPTION

Furnish and place flowable backfill for trench, hole, or other void.

2. MATERIALS

Use materials from prequalified sources listed on the Department website. Use materials from non-listed sources only when tested and approved before use. Allow 30 calendar days for the Engineer to sample, test, and report results for non-listed sources. Do not combine approved material with unapproved material.

2.1 **Cement.** Furnish cement in accordance with DMS-4600, "Hydraulic Cement."

2.2 **Fly Ash.** Furnish fly ash in accordance with DMS-4610, "Fly Ash."

2.3 **Chemical Admixtures.** Furnish chemical admixtures in accordance with DMS-4640, "Chemical Admixtures for Concrete." Use specialty type admixtures to enhance the flowability, reduce shrinkage, and reduce segregation by maintaining solids in suspension when necessary. Use and proportion all admixtures in accordance with the manufacturer's recommendations.

2.4 **Fine Aggregate.** Provide fine aggregate that will stay in suspension in the mortar to the extent required for proper flow and that meets the gradation requirements of Table 1.

Table 1
Aggregate Gradation Chart

Sieve Size	Percent Passing
3/4"	100
#200	0-30

Test fine aggregate gradation in accordance with Tex-401-A.

Plasticity Index (PI) must not exceed 6 when tested in accordance with Tex-106-E.

2.5 **Mixing Water.** Use mixing water in accordance with Item 421, "Hydraulic Cement Concrete."

3. CONSTRUCTION

Submit a construction method and plan, including mix design, for approval. Provide a means of filling the entire void area, and be able to demonstrate this has been accomplished. Prevent the movement of any inserted structure from its designated location. Remove and replace or correct the problem if voids are found in the fill or any of the requirements are not met as shown on the plans without additional cost to the Department.

Furnish a mix meeting the requirements of Table 2 unless otherwise shown on the plans.

Table 2
Flowable Fill Mix Design Requirements

Property	Excavatable	Non-Excavatable	Test Method
28-day Compressive Strength, ¹ psi	80 to 200	> 200	ASTM D4832
Consistency, ² Min diameter, in.	8		ASTM D6103
Unit Weight, pcf	90 to 125	100 to 145	ASTM D6023
Air Content, %	10 to 30	5 to 15	ASTM D6023

1. Average of 2 specimens.
2. Mixture must not segregate.

Mix the flowable fill using a central-mixed concrete plant, ready-mix concrete truck, pug mill, or other approved method.

Furnish all labor, equipment, tools, containers, and molds required for sampling, making, transporting, curing, removal, and disposal of test specimens. Furnish test molds meeting the requirements of Tex-447-A. Transport, strip, and cure the test specimens as scheduled at the designated location. Cure test specimens in accordance with Tex-447-A. The Engineer will sample, make, and test all specimens. Dispose of used, broken specimens in an approved location and manner. The frequency of job-control testing will be at the direction of the Engineer.

4. MEASUREMENT

This Item will be measured by the cubic yard of material placed. Measurement will not include additional volume caused by slips, slides, or cave-ins resulting from the Contractor's operations.

5. PAYMENT

The work performed and materials furnished in accordance with this Item and measured as provided under "Measurement" will be paid for at the unit price bid for "Flowable Backfill." This price is full compensation for furnishing, hauling, and placing materials and for equipment, tools, labor, and incidentals.

Item 402

Trench Excavation Protection



1. DESCRIPTION

Furnish and place excavation protection for trenches 5 ft. or greater in depth.

2. CONSTRUCTION

Provide vertical or sloped cuts, benches, shields, support systems, or other systems providing the necessary protection in accordance with OSHA Standards and Interpretations, 29 CFR Part 1926, Subpart P, "Excavations."

3. MEASUREMENT

This Item will be measured by the foot along the long axis of the trench where the depth of trench exceeds 5 ft. This measurement includes all required trench protection, including trench ends.

4. PAYMENT

The work performed and materials furnished in accordance with this Item and measured as provided under "Measurement" will be paid for at the unit price bid for "Trench Excavation Protection." This price is full compensation for excavation and backfill required for excavation protection; furnishing, placing, and removing shoring, sheeting, or bracing; de-watering or diversion of water; jacking and jack removal; and equipment, labor, materials, tools, and incidentals.

Item 403

Temporary Special Shoring



1. DESCRIPTION

Furnish and install temporary shoring to hold the surrounding earth, water, or both out of the work area.

2. MATERIALS

Furnish new or used materials. Furnish materials that meet the requirements of Item 423, "Retaining Walls," when using temporary Mechanically Stabilized Earth (MSE) walls. Furnish materials that meet the requirements of Item 410, "Soil Nail Anchors," or Item 411, "Rock Nail Anchors," when using temporary nailed walls (rock or soil).

3. CONSTRUCTION

The Contractor is responsible for the temporary special shoring design unless complete details are included on the plans. Submit details and design calculations bearing the seal of a licensed professional engineer before constructing the shoring. The Department reserves the right to reject designs. Design the shoring to comply with OSHA Standards and Interpretations, 29 CFR Part 1926, Subpart P, "Excavations." Design structural systems to comply with AASHTO *Standard Specifications for Highway Bridges* or AASHTO LRFD *Bridge Design Specifications*. Design shoring subject to railroad loading to comply with the AREMA *Manual for Railway Engineering* and any additional requirements of the railway being supported.

Provide vertical or sloped cuts, benches, shields, support systems, or other systems to provide the necessary protection in accordance with the approved design. Construct temporary MSE walls, when used, in accordance with Item 423, "Retaining Walls." Construct temporary nailed walls (rock or soil), when used, in accordance with Item 410, "Soil Nail Anchors," or Item 411, "Rock Nail Anchors."

4. MEASUREMENT

This Item will be measured by the square foot of surface area of a vertical plane at the face of the shoring between the top of the ground being supported and the minimum protection grade line shown on the plans. If no minimum protection grade is shown on the plans, the lowest required excavated elevation will be used. Shoring projecting above the level of the ground being supported will not be measured. When excavation techniques (e.g., sloped cuts or benching) are used to provide the necessary protection, the surface area for payment will be calculated based on the area described by a vertical plane adjacent to the structure.

5. PAYMENT

The work performed and materials furnished in accordance with this Item and measured as provided under "Measurement" will be paid for at the unit price bid for "Temporary Special Shoring." This price is full compensation for excavation and backfill; furnishing, placing and removing shoring, sheeting, or bracing; de-watering or diversion of water; jacking and jack removal; and equipment, labor, materials, tools, and incidentals.

No payment will be made for special shoring made necessary by the selection of an optional design or sequence of work that creates the need for shoring.

Item 404

Driving Piling



1. DESCRIPTION

Drive piling.

2. EQUIPMENT

- 2.1. **Driving Equipment.** Use power hammers for driving piling with specified bearing resistance. Use power hammers that comply with Table 1. Gravity hammers may be used for driving sheet piling and timber piling if no required design load is shown on the plans.

For initial rating of diesel hammers to determine compliance with the requirements of Table 1, the height of fall of the ram of the single-acting (open-end) hammer must be 7 ft. For a double-acting (enclosed ram) hammer, the energy rating must be 85% of the rated output by the manufacturer.

A hammer that produces less energy than required by Table 1 may be approved if a wave equation analysis indicates the hammer can drive the specified pile against a bearing resistance of 3 times the required design load before reaching 0.1 in. of penetration per blow. The bearing resistance of the piling driven with this particular equipment will be determined in accordance with the Wave Equation Method.

Use an air compressor that supplies the volume and pressure specified by the manufacturer of the hammer. Provide an accurate pressure gauge.

Maintain the valve mechanism and other parts of power hammers so the hammer will operate at the speed and stroke length specified by the manufacturer.

Equip enclosed ram diesel hammers with a gauge and provide charts to evaluate the equivalent energy being produced. Calibrate the gauge before work begins, whenever gauge accuracy is in question, and at least once each 6 months.

Table 1
Size of Driving Equipment

Piling Type	Hammer Type	Ram Weight (lb.)	Maximum Ram Stroke (ft.)	Minimum Hammer Energy (ft.-lb.) ¹
Timber	Air, Hydraulic	2,000 Min	5	330R
	Diesel	2,000 Min	10	330R
Steel	Air, Hydraulic	3,000 Min	5	Larger of 250R or 2-1/2 Wp
	Diesel	2,000 Min	10	Larger of 250R or 2-1/2 Wp
Concrete	Air, Hydraulic	3,000 Min, but not less than 1/4 Wp	5	250R, but not less than 1 ft.-lb. per pound of pile weight
	Diesel	2,700 Min, but not less than 1/4 Wp	8 ²	250R, but not less than 1 ft.-lb. per pound of pile weight

- R = Design load in tons. Wp = Weight of pile in pounds based on plan length.
- Diesel hammers with less ram weight or greater ram stroke are permitted if a wave equation analysis indicates the combination of ram weight, stroke, and cushioning will not overstress the piling.

Provide hammer cushion consisting of layers of micarta and aluminum or other material specifically produced and approved for this application. Use a wood, wire rope, or asbestos hammer cushion only if permitted.

Regulate the height of fall when using gravity hammers to avoid damage to the piling.

Drive all test piling in a structure or in any approved segment of it with the same hammer, and use the same type and size hammer to drive the remainder of the piling in the structure or segment.

Equip pile drivers with leads constructed to allow freedom of movement of the hammer and to provide adequate support to the pile during driving. The longitudinal axis of the leads, hammer, and pile should coincide.

Ensure leads are long enough, except where piling is driven through water, that a follower will not be necessary. Use 1 pile in each 10 that is long enough to permit driving without a follower when driving piling underwater and a follower is required. Drive it as a test pile for proper correlation of the follower-driven piling. Payment will be made as regular piling.

Hammers designed to operate underwater may be used for underwater driving without a follower and without the correlation required for other hammers.

- 2.2. **Protection of Pile Heads.** Use a steel driving head (helmet) suitable for the type and size of piling. Drive steel H-piling and sheet piling with a helmet compatible with the specific pile shape driven.

Provide a cushion block for concrete piling between the driving head and the top of the pile. Use a cushion block that is a minimum of 4 in. thick for short piling (50 ft. or less) and at least 6 in. thick for longer piling unless otherwise directed. Use multiple layers of one of the following:

- 3/4-in. or 1-in. structural grade southern pine or fir plywood;
- green oak or gum, with the grain of the wood horizontal; or
- other approved material specifically produced for this application.

Pay special attention to the condition of the cushioning material. Drive no more than 3 piles with one cushion block. Change cushioning more frequently if necessary to prevent damage. Immediately replace any cushion block that has ignited. Do not use a tight-fitting driving helmet for concrete piling. Allow room for slight movement, but ensure the driving helmet is not large enough for the pile head to rotate freely. Center concrete piling and cushion within the helmet throughout the driving operation.

3. CONSTRUCTION

This Item uses the following terms:

- **Foundation Piling.** Piling placed under interior bent footings or retaining wall abutment footings.
- **Trestle Piling.** Piling embedded directly into the abutment cap or interior bent cap.
- **Sheet Piling.** Retaining piling not considered either foundation or trestle piling.
- **Test Piling.** Specific piling driven to investigate site conditions and determine regular piling lengths.
- **Test-Loaded Piling.** Specific piling driven and test-loaded to investigate site conditions and determine regular piling lengths. Do not fabricate regular piling until test loading and analysis is completed.
- **Regular Piling.** All piling other than test piling and test-loaded piling.

Do not fabricate regular piling until test pile-driving and analysis or test loading and analysis is completed.

Complete the embankment at bridge ends before driving abutment piling. Refer to Item 423, "Retaining Walls," for provisions on piling that passes through the structural volume of retaining walls.

Do not drive foundation piling until the footing excavation is complete. Drive concrete piling once the piling concrete, including build-ups, has aged at least 14 days. Do not drive piling in a saltwater environment until the piling concrete, including build-ups, has aged at least 21 days after concrete placement.

Re-drive any piling that is raised when driving adjacent piling. Withdraw and replace any broken, split, or displaced piling, or correct it as directed after a design analysis.

To control excessive stresses resulting in damage to the piling during driving, the following, alone or in combination, may be required:

- increase in cushion thickness,
- reduction of ram stroke,
- heavier ram with a shorter stroke,
- use of pilot holes or jetting when driving through hard or alternating hard and soft strata.

3.1. **Tolerance for Driving.** Drive piling to the required vertical or batter alignment, within the tolerances of this Section. Drive piling in pilot holes or with templates when necessary to comply with tolerances. Cut off piling reasonably square at the elevation shown on the plans, with a tolerance of no more than 2 in. above or below established cutoff grade. Submit for approval a structural analysis and proposed corrective action, signed and sealed by a licensed professional engineer when tolerances are exceeded and the Engineer requires corrective action.

3.1.1. **Trestle Piling.**

- Transverse to the centerline of the bent, the top of the piling may be no more than 2 in. from the position shown on the plans.
- Parallel to the centerline of the bent, the top of the piling may be no more than 4 in. from the position shown on the plans.

3.1.2. **Foundation Piling.**

- The top of each pile may be no more than 4 in. in any direction from the position shown on the plans.
- The center of gravity of the piling group may be no more than 3 in. from the center of gravity determined from plan location.
- The minimum edge distance for piling in a footing is 5 in. Additional concrete required to obtain this edge distance and specified reinforcing steel cover will be at the Contractor's expense.

3.2. **Penetration.** Piling lengths shown on the plans are the lengths estimated to give required bearing and for estimating purposes only. Drive piling to plan tip elevations or to greater depths as necessary to obtain the required bearing resistance shown on the plans.

The Engineer will establish regular pile lengths on the basis of the test data when test piling or test-loaded piling is used. Drive regular piling to this approximate elevation in these cases and to greater depths as required to obtain the plan bearing resistance.

Provide either pilot holes, jetting, or a combination of both for unusually hard driving conditions, typically less than 0.1 in. of penetration per blow if plan penetration is not obtained. Reduce penetration upon approval when the piling is advanced to within 5 ft. of plan length unless other penetration requirements or bearing evaluation methods govern.

3.3. **Pilot Holes.** Extend pilot holes no more than 5 ft. below the bottom of footings for foundation piling or 10 ft. below finished ground line for trestle piling, unless the specified penetration cannot be obtained by using the depth of holes indicated or specified. Determine the size and depth of pilot holes from the results of trial operations on the first piling driven or from available test pile data when deeper ones are required. Obtain approval for any excess depth or size of pilot holes. The maximum hole diameter permitted will be approximately 4 in. less than the diagonal of square piling or steel H-piling and 1 in. less than the diameter of round piling. The Engineer may vary hole size and depth to obtain penetration and bearing resistance.

Extend pilot holes through all embankments to natural ground when driving concrete piling.

Where a pilot hole is required in granular material that cannot be sealed off by ordinary drilling methods, a casing may be required around the boring device deep enough to prevent loose material from falling into the pilot hole.

Drive the piling below the depth of the pilot hole a minimum of 1 ft. or 100 blows, but not less than the required bearing resistance shown on the plans. Do not drive piling beyond the point where the penetration per blow is less than 0.1 in. as determined by an average of 10 blows unless directed otherwise. Stop driving if damage to the pile is apparent.

- 3.4. **Jetting.** Jetting is permitted when the specified penetration cannot be obtained by driving and pilot holes or other methods are not feasible. Submit details of the proposed methods for approval before jetting. The Engineer may authorize varying depths of jetting to achieve the desired results.

Jet as required in conjunction with driving but only to the approved depth. Use enough power for jetting operations to simultaneously operate at least two 2-1/2 in. diameter pipes equipped with 3/4-in. nozzles at a pressure of 150 psi. Perform the jetting with 1 or 2 jets as determined and approved from results of trial operations.

Drive the piling below the depth of the jetting a minimum of 1 ft. or 100 blows, but not less than the required bearing resistance shown on the plans. Do not drive piling beyond the point where the penetration per blow is less than 0.1 in. as determined by an average of 10 blows unless directed otherwise. Stop driving if damage to the pile is apparent.

- 3.5. **Hammer Formula Method of Bearing Evaluation.** Determine the allowable dynamic bearing resistance of piling by one of the hammer formulas in this Section unless otherwise shown on the plans. If the Engineer has determined a K factor based on test piling, test-loaded piling, or other methods, the computed allowable resistance will be the driving resistance determined based on the appropriate formula multiplied by the K factor. The computed allowable resistance should be greater than or equal to the foundation load shown on the plans.

- 3.5.1. **Single-Acting Power Hammers.** Use the following formula:

$$P_a = \frac{2WH}{S + 0.1}$$

where:

P_a = allowable dynamic resistance in pounds

W = weight of ram in pounds

H = height of fall of ram in feet (field measured)

S = average penetration in inches per blow for the last 20 blows

Determine H by an approved electronic stroke indicator and blow count logging device provided by the Contractor. Pending approval, H can be determined by visual observation of the ram against a calibrated rod mounted on the hammer or by the following formula:

$$H = 16.1 \times \left(\frac{30}{B} \right)^2 - 0.3$$

where B = blows per minute

- 3.5.2. **Double-Acting Power Hammers.** Use the following formula:

$$P_a = \frac{2E}{S + 0.1}$$

where:

P_a = allowable dynamic resistance in pounds

E = manufacturer's rated energy in foot-pounds (for double-acting power hammers), or the equivalent energy in foot-pounds determined by a calibrated gauge attached to the hammer and taken when the average

penetration in inches per blow is determined (for enclosed ram diesel hammer)
 S = average penetration in inches per blow for the last 20 blows

3.5.3. **Other Hammer Types.** Provide a wave equation analysis for each pile, hammer, soil, and load combination for which the driving system is to be used. The analysis will determine the bearing capacity of the piling.

3.6. **Wave Equation Method of Bearing Evaluation.** Submit the following data when plans specify the bearing capacity of the piling be determined by the wave equation method:

- manufacturer's specification data for the hammer proposed for use, including all modifications and
- complete description and dimensions of all cushioning material used between the pile and helmet and in the cap block, including total thickness of each, and the direction of grain if wood is used.

These data are used by the Engineer to determine the required number of blows per unit of penetration the hammer must deliver to obtain the required bearing resistance.

After evaluation by the wave equation method, any change in the driving equipment may require re-evaluation. Such changes must be approved before further driving.

3.7. **Test Piling.** Drive test piling at locations shown on the plans or as directed. Make test piling part of the completed work, cut off or built up to grade as necessary. Use the required bearing evaluation method to determine bearing resistance.

Initially drive test piling to 3 ft. above plan tip elevation of the regular piling for the structure with the blow count recorded for each foot of driving (for example, drive test piling to 13 ft. above its plan tip elevation if the test piling is 10 ft. longer than regular piling). Retain the cushion if used.

Re-drive the test piling the additional length required by the plans at least 7 days after the original driving with the same hammer and cushion originally used. Record the blow count for each inch of driving for the first foot, for every 3 in. for the next 2 ft., and for each foot thereafter.

Provide the data to the Engineer for use in determining regular piling lengths and K factors. The K factor will be determined based on the following formula:

$$K = P_R/P$$

where:

K = a static correction factor applied to the evaluation method

P_R = re-drive bearing (tons) of the test pile determined by the evaluation method

P = original bearing (tons) of test pile determined by the evaluation method

3.8. **Test-Loaded Piling.** Conduct test load in accordance with Item 405, "Foundation Load Test."

Provide the data to the Engineer for use in determining regular piling lengths and K factors. The K factor will be determined based on the following formula:

$$K = L/P$$

where:

K = a static correction factor applied to the evaluation method

L = maximum safe static load proven by test load

P = bearing resistance of the test-loaded pile determined by the evaluation method

4. MEASUREMENT AND PAYMENT

The work performed, materials furnished, equipment, labor, tools, and incidentals will not be paid for directly but will be considered subsidiary to pertinent Items.

Item 405

Foundation Load Test



1. DESCRIPTION

Load-test piling or drilled shafts.

2. MATERIALS

Provide piling or drilled shafts for test loading as shown on the plans.

3. EQUIPMENT

Furnish all necessary tools and equipment required to perform the foundation load test.

4. CONSTRUCTION

Furnish and drive the piling in accordance with Item 404, "Driving Piling," or construct the shaft in accordance with Item 416, "Drilled Shaft Foundations," to be test-loaded. Use the same procedure for drilling the test shaft as for the shafts required in the structure.

Keep a complete record of pile-driving data and shaft-drilling data for all foundations used in the test load. Apply the test load no earlier than the seventh day after driving the test piling or after placing concrete in the test shaft. Load the test shaft only after the concrete design strength has been attained.

Perform the foundation load test as stated on the plans and in accordance with the following:

- ASTM D1143
- ASTM D4945
- ASTM D7383

Dismantle the test setup after completing the test if applicable.

Remove piling or shafts that are not part of the structure upon completion of the test load, or cut off at least 1 ft. below the bottom of the footing or the finished grade. Re-drive permanent piling to its original grade and bearing if it is raised during the test load.

5. MEASUREMENT

Measurement will be made for each complete test load satisfactorily performed, reported, and accepted.

6. PAYMENT

The work performed and materials furnished in accordance with this Item and measured as provided under "Measurement" will be paid for at the unit price bid for each "Foundation Load Test." This price is full compensation for material, equipment, labor, work, tools, and incidentals.

Test piling or test shafts that are not part of the permanent structure will not be paid for directly but will be subsidiary to this Item. Test piling or test shafts that are part of the permanent structure will be paid for under the pertinent Items.

Item 406

Timber Piling



1. DESCRIPTION

Furnish and place treated or untreated timber piling.

2. MATERIALS

Furnish timber piling in accordance with ASTM D25. Use any species of durable timber for untreated piling that will satisfactorily stand driving. Use Southern pine or Douglas fir impregnated with a preservative for treated piling in accordance with Item 492, "Timber Preservative and Treatment," or as shown on the plans.

Furnish round piling in the lengths shown on the plans, with a minimum circumference of 38 in. for piling 40 ft. or less in length, and 41 in. for piling over 40 ft. Measure the circumference under the bark at a section 3 ft. from the butt.

Treat cuts, bolt holes, and other areas where the surface of the piling is broken in accordance with Item 492, "Timber Preservative and Treatment."

2.1. **Inspection.** All piling is subject to inspection before and after treatment. Allow the inspector free access to all sites where materials are being produced or processed, and provide any assistance necessary for the proper inspection of materials. The engineer or inspection agency that performed the inspection must brand the butt and tip of each acceptable pile with a marking hammer showing identity of the engineer or inspection agency.

2.2. **Storing and Handling.** Prevent excessive splitting, checking, warping, distortion, or any other damage that may cause the piling to be rejected. Handle treated timber piling carefully without dropping, breaking outer fibers, bruising, or penetrating the surface with tools.

3. EQUIPMENT

Handle piling with rope slings. Use handling equipment that does not penetrate the treated shell into untreated wood.

4. CONSTRUCTION

Drive piling in accordance with Item 404, "Driving Piling."

4.1. **Splices, Build-Ups, and Cutoffs.** Saw tops of all piling to a true plane as shown on the plans and at the established elevation. Saw piling that supports timber caps or connects to other members to the exact plane of the connected member.

Build up piling by splicing on an additional length of piling of the same diameter and quality when required. Make splices in accordance with the details shown on the plans or as directed. Construct the splice after the pile head and the lower end of the build-up section have been squared up and treated in accordance with Section 406.4.2., "Treatment of Pile Ends." Use a long enough build-up section to preclude the need for more than 1 splice. Use no more than 1 splice in any single pile.

4.2. Treatment of Pile Ends.

4.2.1. **Treated Timber.** Give the ends of piling 3 coats of a preservative determined appropriate for the original preservative per AWPA Standard M4 after cutting. Follow with one coat of coal-tar roofing cement meeting the requirements of ASTM D5643.

4.2.2. **Untreated Timber.** Coat the heads of piling thoroughly with a thick protective coat of hot tar, hot asphaltum, or hot creosote.

Cover the pile heads after treatment with a sheet of 20-gauge galvanized metal when indicated on the plans. Provide a cover that overlaps the sides of the piling at least 3 in. Bend the cover down over the piling and fasten it with large-headed galvanized nails or as shown on the plans.

Treat cutting or hole boring that has occurred after treatment or a damaged surface of treated piling in accordance with Item 492, "Timber Preservative and Treatment."

5. MEASUREMENT

5.1. **Timber Piling.** Timber piling will be measured by the foot of acceptable piling in place after all cutoffs and splices have been made. When the Contractor elects to drive piling deeper than required to meet the specified length and bearing requirements, no measurement will be made on that portion below the elevation at which length and bearing requirements were first obtained.

5.2. **Splices.** Splices will be measured by each authorized, completed splice made necessary by driving beyond the plan pile length to obtain required bearing resistance. No measurement will be made for a splice made necessary by unsuitable material, handling, driving, or overdriving.

5.3. **Cutoffs.** Cutoffs will be measured by the foot of cutoff above required grade. No cutoff will be measured on any pile that is built up.

6. PAYMENT

The price bid is full compensation for jetting, pilot holes, alignment holes, driving piling, repairs, materials, equipment, tools, labor, and incidentals.

6.1. **Timber Piling.** The work performed and materials furnished in accordance with this Item and measured as provided under "Measurement" will be paid for at the unit price of "Treated Timber Piling" or "Untreated Timber Piling."

6.2. **Splices.** An additional payment for each authorized, completed splice, regardless of build-up length, will be made at a price equal to 4 times the unit price bid for "Treated Timber Piling" or "Untreated Timber Piling." Where piling is trimmed back for the purpose of constructing a splice, payment for the cutoff is included in the payment for the splice.

6.3. **Cutoffs.** Payment for cutoff lengths will be made at a price equal to 1/2 the unit price bid for "Treated Timber Piling" or "Untreated Timber Piling."

Item 407

Steel Piling



1. DESCRIPTION

Furnish and place steel H-piling, pipe piling, and sheet piling.

2. MATERIALS

Furnish steel H-piling, pipe piling, and steel sheet piling in accordance with Item 441, "Steel Structures," and details shown on the plans.

Furnish steel that meets ASTM A690 or ASTM A572 Grade 50 for H-piling. Furnish steel that meets ASTM A572 Grade 50 for pipe piling. Furnish steel that meets ASTM A328, ASTM A690, or ASTM A572 Grade 50 for hot-rolled sheet piling. Furnish steel that meets ASTM A690 or ASTM A572 Grade 50 for cold-rolled sheet piling. Steel sheet piling may be substituted with a section modulus and minimum thickness of material equal to or greater than that of the section specified. If a hot-rolled section is specified, the substitute section must also be hot-rolled.

Furnish piling in the lengths indicated on the plans. The Engineer will approve lengths based on test driving data or test load data where test piling is required. Fabricate piling once the Engineer has determined the approved lengths.

At the Contractor's expense, the H-piling or pipe piling may be fabricated by welding together up to 3 sections of piling with a minimum section length of 5 ft.

Shop-paint piling with 3.0 mils minimum Dry Film Thickness (DFT) inorganic zinc primer in accordance with the System III-B or IV paint protection system specified in Item 441, "Steel Structures," unless otherwise shown on the plans. Apply appearance or intermediate coatings only if specified on the plans. Apply a marine-grade immersion coating system recommended by the manufacturer for marine, immersion service, and meeting the requirements of NORSOK Standard M-501, Coating System No. 7 for piling in marine environments. Submit a manufacturer's certification that states the material meets the requirements of NORSOK Standard M-501, Coating System No. 7. Submit product data sheets and obtain approval of paint system before performing the work. Paint the portion of the pile to be above finished grade or dredge line, in water, and a minimum distance of 15 ft. below finished grade or dredge line, unless otherwise shown on the plans. Provide coatings for field painting in accordance with Item 446, "Field Cleaning and Painting Steel."

Reinforce steel H-pile tips as directed when the piling is to be driven into rock, shale, or other material of similar hardness. Use the pile tip reinforcement detail shown on Common Foundation Details (FD) Standard or attach prefabricated pile points manufactured from ASTM A27 Grade 65-35 or ASTM A148 Grade 80-50 material. Furnish certification materials conforming to this requirement. Submit construction drawings for approval when alternate pile tip reinforcements are proposed.

Reinforce steel pipe piling and steel sheet piling tip as directed when piling is to be driven into rock, shale, or other material of similar hardness. Use prefabricated pipe piling or sheet piling tip reinforcements manufactured from ASTM A27 Grade 65-35 or ASTM A148 Grade 80-50 material. Submit construction drawings for approval when alternate pipe piling or sheet piling tip reinforcements are proposed.

Store piling above ground on adequate blocking. Keep piling clean and fully drained at all times during storage.

3. CONSTRUCTION

Drive piling in accordance with Item 404, "Driving Piling." Test load, when required, in accordance with Item 405, "Foundation Load Test."

- 3.1. **Splices and Cutoffs.** Make all splices for steel H-piling in accordance with detail on Common Foundation Details (FD) Standard. Submit pipe piling and sheet piling splicing locations and details of Record for approval. Drive spliced piling the additional depth required as soon as the splice is completed if the required penetration or bearing resistance has not been obtained.

Cut piling off square at plan grade or to the established grade after driving it to the approximate penetration and bearing resistance required. Cut off the damaged portion if the head of the pile is appreciably distorted or otherwise damaged below cutoff level, and splice an undamaged section in its place, at no additional expense to the Department.

Weld in accordance with Item 448, "Structural Field Welding."

- 3.2. **Painting.** Spot clean and paint in accordance with Item 446, "Field Cleaning and Painting Steel." Clean and paint damaged areas, field splices, or areas missing the shop coat, for IOZ primed piling, with enough epoxy zinc primer to bring the total zinc primer to the minimum 3.0 mils DFT after driving piling. Follow the repair procedures recommended by the manufacturer of the marine grade immersion coating system for piling with marine grade immersion coatings. Apply at least 2.0 mils DFT each of the System III epoxy intermediate coating and appearance coating when a polyurethane appearance coating is specified on the plans. Apply at least 2.0 mils DFT of the System IV appearance coating when an acrylic latex appearance coating is specified on the plans. Use a concrete gray appearance coating unless shown otherwise on the plans. Extend the appearance coat 1 ft. below finished ground line unless the piling is standing in water, in which case extend the appearance coat to the low water line. Replace any earth removed for this painting after the paint has dried.
- 3.3. **Test Piling.** Test piling must meet requirements for steel piling. The Engineer may adjust the number of test piling to secure desired information.

4. MEASUREMENT

4.1. Steel H-Piling and Pipe Piling.

- 4.1.1. **Steel Piling.** Steel H-piling, Steel H-test piling, Steel Pipe piling, and Steel Pipe-test piling will be measured by the foot of acceptable piling in place after all cutoffs and splices have been made. When the Contractor elects to drive piling deeper than required to meet the specified length and bearing requirements, no measurement will be made on that portion below the elevation at which length and bearing requirements were first obtained.

- 4.1.2. **Splices.** Splices will be measured by each authorized splice made necessary by driving beyond the plan pile length to obtain the required bearing resistance.

- 4.1.3. **Reinforced Tips.** Reinforced tips will be measured by each pile tip when required.

4.2. Steel Sheet Piling.

- 4.2.1. **Steel Piling.** Steel sheet piling will be measured by the square foot of acceptable piling in place. Sheet piling driven below the elevation required by the plans or the elevation authorized by the Engineer will not be measured for payment.

- 4.2.2. **Reinforced Tips.** Reinforced tips will be measured by each pile tip when required.

5. PAYMENT

No direct payment will be made for painting or excavation and backfill required for the painting of portions of piling below ground line. Payment for all work and materials required by these items will be included in the unit price bid for "Steel H-Piling," "Steel H-Test Piling," "Sheet Piling," "Steel Pipe Piling," or "Steel Pipe Test Pile."

The price bid is full compensation for jetting, pilot holes, alignment holes, driving piling, painting, materials, tools, equipment, labor, and incidentals. Any test load ordered by the Engineer that is not provided for in the Contract will be paid for in accordance with Article 9.7., "Payment for Extra Work and Force Account Method."

5.1. Steel H-Piling and Pipe Piling.

5.1.1. Steel Piling. The work performed and materials furnished in accordance with this Item and measured as provided under "Measurement" will be paid for at the unit price bid for the specified size and weight of "Steel H-Piling," "Steel H-Test Piling," "Steel Pipe Piling," or "Steel Pipe Test Piling."

5.1.2. Splices. Payment for each completed authorized splice for both regular and test piling, regardless of buildup length, will be made at a price equal to 4 times the unit price bid for "Steel H-Piling" or "Steel Pipe Piling."

5.1.3. Cutoffs. Cutoffs will not be paid for directly but will be subsidiary to this Item.

5.1.4. Reinforced Tips. Payment for each completed authorized pile tip for both regular and test piling will be made at a price equal to 2 times the unit price bid for "Steel H-Piling" or "Steel Pipe Piling."

5.2. Steel Sheet Piling.

5.2.1. Steel Piling. Steel sheet piling will be paid for at the unit price bid per square foot for "Sheet Piling" of the type shown on the plans. No payment will be made for cutoffs or splices of sheet piling.

5.2.2. Reinforced Tips. Payment for each completed authorized pile tip will be made at a price equal to 2 times the unit price bid for "Steel Sheet Piling."

Item 409

Prestressed Concrete Piling



1. DESCRIPTION

Furnish and place prestressed concrete piling.

2. MATERIALS

Use materials that meet the requirements of the following Items.

- Item 420, "Concrete Substructures"
- Item 421, "Hydraulic Cement Concrete"
- Item 425, "Precast Prestressed Concrete Structural Members"
- Item 440, "Reinforcement for Concrete"

Fabricate prestressed concrete piling in accordance with the following Items.

- Item 424, "Precast Concrete Structural Members (Fabrication)"
- Item 425, "Precast Prestressed Concrete Structural Members"

Furnish piling in the lengths indicated on the plans when test or test-loaded piling is not required. When test or test-loaded piling is required, the Engineer will approve lengths based on test driving data or test load data. Cast regular piling only after the Engineer has determined the approved lengths based on the test or test-loaded piling.

3. CONSTRUCTION

Handle and store piling in a way that minimizes the risk of damage by impact or bending stress. Store piling above ground on adequate blocking. Do not use chain slings to handle piling. Immediately review and correct conditions causing the damage to any piling. Drive piling in accordance with Item 404, "Driving Piling." Test-load, when required, in accordance with Item 405, "Foundation Load Test."

- 3.1. **Defects and Breakage.** Damage to piling due to faulty materials or construction methods may be cause for rejection. Piling damaged in the process of fabrication, handling, storing, hauling, or driving is subject to the acceptance criteria and repair provisions set forth in the *Concrete Repair Manual*.
- 3.2. **Buildups and Cutoffs.** Construct buildups in accordance with plan details and Item 420, "Concrete Substructures." Make the final cut of the concrete square to the longitudinal axis for cutoffs.
- 3.3. **Test Piling.** Test piling must meet requirements for prestressed concrete piling. The Engineer may adjust the number of test piles to secure desired information.

4. MEASUREMENT

- 4.1. **Concrete Piling.** Prestressed concrete piling and prestressed concrete test piling will be measured by the foot of acceptable piling in place after all cutoffs and buildups have been made. When the Contractor elects to drive piling deeper than required to meet the specified length and bearing requirements, no measurement will be made on that portion below the elevation at which length and bearing requirements were first obtained.

- 4.2. **Buildups.** Buildups will be measured by each authorized, completed buildup made necessary by driving beyond the plan pile length to obtain required bearing resistance. No measurement will be made for a buildup made necessary by improper casting, handling, or driving.
- 4.3. **Cutoffs.** Cutoffs for both regular and test piling will be measured by the foot of cutoff above required grade.

5. PAYMENT

The price bid is full compensation for jetting, pilot holes, alignment holes, repairs, materials, tools, equipment, labor, and incidentals. Test-loaded piling and associated anchor piling will be paid for as provided in Item 405, "Foundation Load Test." Any test load ordered by the Engineer that is not provided for in the Contract will be paid for in accordance with Article 9.7., "Payment for Extra Work and Force Account Method."

- 5.1. **Concrete Piling.** The work performed and materials furnished in accordance with this Item and measured as provided under "Measurement" will be paid for at the unit price bid for "Prestressed Concrete Piling" or "Prestressed Concrete Test Piling" of the size specified.
- 5.2. **Buildups.** An additional payment for each completed authorized buildup splice for both regular and test piling, regardless of buildup length, will be made at a price equal to 10 times the unit price bid for "Prestressed Concrete Piling." Where piling is broken back for constructing buildups, payment for the breakback is included in the payment for buildups.
- 5.3. **Cutoffs.** Payment for cutoff lengths of both regular piling and test piling will be made at a price equal to 1/2 the unit price bid per foot for "Prestressed Concrete Piling." Payment for cut is included in the payment for cutoffs.

Item 410

Soil Nail Anchors



1. DESCRIPTION

Construct reinforced soil nail anchors.

2. MATERIALS

Provide materials conforming to the following requirements.

- 2.1. **Hydraulic Cement Concrete.** Use materials that meet the requirements of Item 421, "Hydraulic Cement Concrete." Provide a neat cement or sand-cement mixture for the grout for soil nail anchors with a 7-day compressive strength of 3,000 psi. Determine grout strength by testing the grout used for the test soil nail anchors in cubes in accordance with Tex-307-D or cylinders in accordance with Tex-418-A. Test further as directed or if the grout mixture is modified. Fly ash may be included in the grout.

Do not use grout mixed in a mobile continuous volumetric mixer.

Provide a grout mix with a minimum water-cement ratio of 0.4 and a minimum specific gravity of 1.85. Test for specific gravity in accordance with Tex-130-E.

When a sand-cement mixture is used for grouting soil nail anchors, provide a grout mixture with a minimum slump flow of 20 in. Test the slump flow of the grout in accordance with ASTM C1611.

The need for stiffer grout may arise when the hollow-stem auger drilling method is used or it is desired to control leakage of grout into highly permeable granular soils or highly fractured rock. In these instances, the Engineer may waive the requirements of slump flow testing.

- 2.2. **Pneumatically Placed Concrete.** Use materials that meet the requirements of Class II concrete in Item 431, "Pneumatically Placed Concrete," unless otherwise shown on the plans.
- 2.3. **Reinforcing Steel.** Use materials that meet the requirements of Item 440, "Reinforcement for Concrete." Provide epoxy coated reinforcing steel bar of the size and grade shown on the plans for permanent walls. The minimum allowable epoxy coating thickness is 12 mils.
- 2.4. **Bar Couplers.** Provide bar couplers that develop the full nominal tensile capacity of the soil nail bars as certified by the manufacturer.
- 2.5. **Nail Centralizers.** Provide expanded slit PVC centralizers with a minimum diameter of 1 in. less than the nail-hole. Wheel type centralizers will not be allowed.

3. EQUIPMENT

Furnish suitable equipment to drill the holes to the specified diameter, depth, and line. Provide a drill rig with an articulating head in the vertical plane and continuous flight augers. If an auger becomes worn to the degree that the drilled hole is less than the required diameter, remove the auger from service until it is repaired and can provide a hole of at least the required diameter. Return the auger to service once it is repaired and can provide a hole of at least the required diameter.

Furnish a hydraulic jack and reaction frame for stressing the test anchors. Furnish a pressure gauge for the jack that is graduated in 75 psi increments or less. Furnish a minimum of 2 dial gauges capable of measuring

to 0.001 in. Calibrate the hydraulic jack and ram used together as a system, and furnish certified copies of load calibration curves for all jacks and ram systems to be used in the work. Calibrate the jack and ram as a unit no more than 6 mo. before starting work. Recalibrate stressing systems when directed or at least every 6 mo.

Furnish a grout mixer and pump of sufficient capacity to place grout properly in the required quantities.

4. CONSTRUCTION

4.1. **Soil Nail Wall Construction Plan.** Submit a soil nail wall construction plan at least 30 days before beginning construction. Begin soil nail wall construction once the construction plan submittal is accepted. Provide detailed project-specific information in the soil nail wall construction plan that includes the following:

- Project start date, an overall description, and sequence of soil nail wall construction;
- List and sizes of excavation equipment, drill rigs (must have an articulating head in a vertical plane), cutting head (auger, rock bit, etc.), tools, tremies, and grouting equipment;
- Procedures for the sequence for the following items of work: excavations; drilling and grouting; soil nail and wall drainage system installation; and, if appropriate, facing construction;
- Details of pneumatically placed concrete equipment and application including mix process, shooting methods, and means for determining the thickness of the concrete applied;
- A nozzleman who is certified as an American Concrete Institute (ACI) Shotcrete Nozzelman;
- Plan and methods for nail testing, both the verification tests and proof tests, with calibration certificates dated within 5 mo. of the submittal date; and
- Other information shown on the plans or requested by the Engineer.

4.2. **Drilling.** Drill the hole so that its diameter is not smaller than the diameter shown on the plans or established by test soil nail anchors. Control hole alignment so that it varies no more than 5 degrees from the line specified on the plans. Furnish suitable drilling equipment and use methods suitable for the ground conditions. The use of drilling mud or other fluids to remove cuttings will not be allowed.

4.3. **Grouting.** Place the soil nail anchor with centralizers that are spaced no more than 8 ft. apart in the hole. Set the centralizers to position the soil nail reinforcing bar within 1 in. of the center of the hole. To grout, advance the grouting pipe to the bottom of the hole, and leave it there until the hole is filled with grout and enough unsegregated grout is expelled at the top of the hole. Withdraw the pipe slowly while grouting continues, filling the void left by the grout pipe. Grout each nail within 8 hr. of the completion of drilling. Holes open longer than 8 hr. will be rejected and backfilled with grout.

Grouting before insertion of the epoxy coated bar into the hole is only allowed with approval. If approved, advance the grout pipe to the bottom of the hole and leave it there until the hole is filled with grout and enough unsegregated grout is expelled at the top of the hole. Withdraw the pipe slowly while grouting continues, filling the void left by the grout pipe. Insert the epoxy coated bar with the centralizers attached and fill any void that is left from the insertion of the bar. Fill the hole completely to face of the cut.

If caving or sloughing of the hole occurs that prevents open-hole grouting, furnish either hollow-stem auger equipment, placing the nail reinforcing bar and grout through the auger, or casing to support the sides of the excavation. Use grouting methods that result in complete filling of the hole at the ground surface. Methods may include placement of grout in multiple stages or other approved methods. Completely remove any device used to dam the front of the hole immediately after the grout takes an initial set.

Record the following information concerning the grouting:

- Type of mixer
- Water-cement ratio
- Types of additives
- Type of cement
- Volume of grout

4.4. Soil Nail Anchor Test.

- 4.4.1. **Verification Tests.** Construct and test the soil nail anchors as indicated on the plans. Test the soil nail anchors before installing any production soil nail anchors. Do not use verification test nails as production soil nail anchors.

Provide an adequate reaction pad large enough to resist the required load without sinking into the soil or shifting laterally during the test. Do not use a reaction pad that sinks into the soil more than 2 in. or that allows the free end of the soil nail reinforcing bar to move laterally more than 2 in. Failure to provide an adequate reaction pad will void the soil nail anchor test. Provide additional test soil nail anchors until an adequate reaction system is achieved. Furnish additional test soil nail anchors, required due to inadequate reaction pads, at no expense to the Department.

Provide a reaction pad with a center opening larger than the hole diameter to ensure that no bridging or interaction occurs between the grout column and the reaction pad. Similarly, remove all pneumatically placed concrete, excess grout, or other foreign material to expose the full face of the grout column. Ensure the reaction system does not contact or interfere with the soil nail anchor reinforcing bar during the test. Conduct the following testing method:

- Apply test loads to soil nail anchors in increments of approximately 10% of the required test load stated on the plans. Hold each load increment long enough to obtain the gauge readings and to ensure that the readings have stabilized. Hold the final maximum test load for 10 min.
- Perform initial tensioning to take the slack out of the testing apparatus at 5% of the required test load unless otherwise directed.
- Provide gauges that extend and retract freely and move smoothly throughout their range. Provide a rigid and secure system to support the gauge independently of the jack or reaction system.
- Verification Test Nail Acceptance Criteria. Unless otherwise shown on the plans, the verification test nail acceptance criteria is:
 - The total creep movement is less than 0.04 in. during the final 10-min. reading increment. If movement exceeds this value, the Engineer may require an additional hold period of up to 60 min. with a maximum 0.08-in. total creep movement including the movement from the original 10-min. hold;
 - The total measured movement at the maximum test load exceeds 80% of the theoretical elastic elongation of the unbonded length of the test nail; and
 - A pullout limit state does not occur for the verification load listed on the plans. Pullout limit state is defined at a load level at which the test load cannot be further increased while there is continued movement of the test nail.

Modify construction methods or procedures if the test soil nail anchors fail to provide the minimum pullout capacity specified on the plans. Install and test additional soil nail test anchors until adequate pullout capacity is achieved. Test soil nail anchors, in addition to the number specified on the plans, are subsidiary to this Item.

Install additional soil nail test anchors following the modified construction procedures and test additional soil nail test anchors if the Contractor chooses to modify construction procedures after test soil nail anchors are completed and approved. This additional testing is subsidiary to this Item.

- 4.4.2. **Proof Tests.** Conduct Proof Testing of production nails when shown on the plans. The number, length, and target load of nail(s) to be proof loaded must be satisfied and tested according to the following criteria:

- The Engineer will determine the locations of each proof test nail. Completely grout the proof test nails. Proof testing may occur before the placement of pneumatically placed concrete for the temporary face. Leave a sufficiently voided region around the nail head to allow free nail movement if proof testing is to occur after the placement of pneumatically placed concrete for the temporary facing. Provide a minimum 2 in. clear zone around the grouted nail.

- Use a reaction system as outlined in Section 410.4.4.1., "Verification Tests."
- Follow proof nail loading sequence outlined for Section 410.4.4.1., "Verification Tests," except use the required proof load stated on the plans.
- Proof Test Nail Acceptance Criteria. Unless otherwise shown on the plans, the proof test nail acceptance criteria is:
 - The total creep movement is less than 0.04 in. during the final 10 min. reading increment. If movement exceeds this value, the Engineer may require an additional hold period of up to 60 min. with a maximum 0.08 in. total creep movement including the movement from the original 10 min. hold.
 - The total measured movement at the maximum test load exceeds 80% of the theoretical elastic elongation of the unbonded length of the test nail.
 - A pullout limit state does not occur for the proof load listed on the plans. Pullout limit state is defined at a load level at which the test load cannot be further increased while there is continued movement of the test nail.
- If the proof test nails fail, the Contractor's engineer is responsible for redesigning the wall with supplemental soil nail anchors.

5. MEASUREMENT

Soil nail anchors will be measured by the foot of acceptable soil nail anchor in place. The soil nail anchor length measured is the length of the drilled and grouted hole as specified on the plans or modified by the Engineer. Soil nail anchor tests, both verification tests and proof tests, are subsidiary to this Item.

6. PAYMENT

The work performed and materials furnished in accordance with this Item and measured as provided under "Measurement" will be paid for at the unit price bid for "Soil Nail Anchors." This price is full compensation for materials, equipment, testing, labor, tools, and incidentals.

Item 411

Rock Nail Anchors



1. DESCRIPTION

Construct reinforced rock nail anchors.

2. MATERIALS

Provide materials conforming to the following requirements.

- 2.1. **Hydraulic Cement Concrete.** Use materials that meet the requirements of Item 421, "Hydraulic Cement Concrete." Provide a neat cement or sand-cement mixture for the grout for rock nail anchors with a 7-day compressive strength of 3,000 psi. Determine grout strength by testing the grout used for the test rock nail anchors in cubes in accordance with Tex-307-D or cylinders in accordance with Tex-418-A. Test further as directed or if the grout mixture is modified. Fly ash may be included in the grout.

Do not use grout mixed in a mobile continuous volumetric mixer.

Provide a grout mix with a minimum water-cement ratio of 0.4 and a minimum specific gravity of 1.85. Test for specific gravity in accordance with Tex-130-E.

When a sand-cement mixture is used for grouting rock nail anchors, provide a grout mixture with a minimum slump flow of 20 in. Test the slump flow of the grout in accordance with ASTM C1611.

The need for stiffer grout may arise when it is desired to control leakage of grout into highly permeable or fractured rock. In these instances, the Engineer may waive the requirements of slump flow testing.

- 2.2. **Pneumatically Placed Concrete.** Use materials that meet the requirements of Class II concrete in Item 431, "Pneumatically Placed Concrete," unless otherwise shown on the plans.
- 2.3. **Reinforcing Steel.** Use materials that meet the requirements of Item 440, "Reinforcement for Concrete." Provide epoxy coated reinforcing steel bar of the size and grade shown on the plans for permanent walls. The minimum allowable epoxy coating thickness is 12 mils.
- 2.4. **Bar Couplers.** Provide bar couplers that develop the full nominal tensile capacity of the rock nail bars, as certified by the manufacturer.
- 2.5. **Nail Centralizers.** Provide expanded slit PVC centralizers with a minimum diameter of 1 in. less than the nail-hole. Wheel type centralizers will not be allowed.

3. EQUIPMENT

Furnish suitable equipment to drill the holes to the specified diameter, depth, and line. Provide a drill rig with an articulating head in the vertical plane and continuous flight augers.

If the auger becomes worn to the degree that the drilled hole is less than the required diameter, remove the auger from service until it is repaired and can provide a hole of at least the required diameter.

Furnish a hydraulic jack and reaction frame for stressing the test anchors. Furnish a pressure gauge for the jack that is graduated in 75 psi increments or less. Furnish a minimum of 2 dial gauges capable of measuring to within 0.001 in. Calibrate the hydraulic jack and ram used together as a system, and furnish certified

copies of load calibration curves for all jacks and ram systems to be used in the work. Calibrate the jack and ram as a unit no more than 6 mo. before starting work. Recalibrate stressing systems when directed or at least every 6 mo.

Furnish a grout mixer and pump of sufficient capacity to place grout properly in the required quantities.

4. CONSTRUCTION

4.1. **Rock Nail Wall Construction Plan.** Submit a rock nail wall construction plan at least 30 days before beginning construction. Begin rock nail wall construction once the construction plan submittal is accepted. Provide detailed project-specific information in the rock nail wall construction plan that includes the following:

- Project start date, an overall description, and sequence of rock nail wall construction;
- List and sizes of excavation equipment, drill rigs (must have an articulating head in a vertical plane), cutting head (auger, rock bit, etc.), tools, tremies, and grouting equipment;
- Procedures for the sequence for the following items of work: excavations; drilling and grouting; rock nail and wall drainage system installation; and, if appropriate, facing construction;
- Details of pneumatically placed concrete equipment and application including mix process, shooting methods, and means for determining the thickness of the concrete applied;
- A nozzleman that is certified as an American Concrete Institute (ACI) Shotcrete Nozzelman;
- Plan and methods for rock nail testing, both the verification tests and proof tests, with calibration certificates dated within 5 months of the submittal date; and
- Other information shown on the plans or requested by the Engineer.

4.2. **Drilling.** Drill the hole so that its diameter is not smaller than the diameter shown on the plans or established by test rock nail anchors. Control hole alignment so that it varies no more than 5 degrees from the line specified on the plans. Furnish suitable drilling equipment and use methods suitable for the ground conditions. The use of drilling mud or other fluids to remove cuttings will not be allowed.

4.3. **Grouting.** Place the rock nail anchor with centralizers that are spaced no more than 8 ft. apart in the hole. Set the centralizers to position the rock nail reinforcing bar within 1 in. of the center of the hole. To grout, advance the grouting pipe to the bottom of the hole, and leave it there until the hole is filled with grout and enough unsegregated grout is expelled at the top of the hole. Withdraw the pipe slowly while grouting continues, filling the void left by the grout pipe. Grout each nail within 8 hr. of the completion of drilling. Holes open longer than 8 hours will be rejected and backfilled with grout.

Grouting before insertion of the epoxy coated bar into the hole is only allowed with approval. If approved, advance the grout pipe to the bottom of the hole and leave it there until the hole is filled and enough unsegregated grout is expelled at the top of the hole. Withdraw the pipe slowly while grouting continues, filling the void left by the grout pipe. Insert the epoxy coated bar with the centralizers attached and fill any void that is left from the insertion of the bar. Fill the hole completely to face of the cut.

If caving or sloughing of the hole occurs that prevents open-hole grouting, furnish either hollow-stem auger equipment, placing the nail reinforcing bar and grout through the auger, or casing to support the sides. Use grouting methods that result in complete filling of the hole at the ground surface. Methods may include placement of grout in multiple stages or other approved methods. Completely remove any device used to dam the front of the hole immediately after the grout takes an initial set.

Record the following information concerning the grouting:

- Type of mixer,
- Water-cement ratio,
- Types of additives,
- Type of cement, and
- Volume of grout.

4.4. **Rock Nail Anchor Test.**

- 4.4.1. **Verification Tests.** Construct and test the rock nail anchors as indicated on the plans. Test the rock nail anchors before installing any production rock nail anchors. Do not use verification test nails as production rock nail anchors.

Provide an adequate reaction pad large enough to resist the required load without sinking into the rock or shifting laterally during the test. Do not use a reaction pad that sinks into the rock more than 2 in. or that allows the free end of the rock nail reinforcing bar to move laterally more than 2 in. Failure to provide an adequate reaction pad will void the rock nail anchor test. Provide additional test rock nail anchors until an adequate reaction system is achieved. Furnish additional test rock nail anchors, required due to inadequate reaction pads, at no expense to the Department.

Provide a reaction pad with a center opening larger than the hole diameter to ensure that no bridging or interaction occurs between the grout column and the reaction pad. Similarly, remove all pneumatically placed concrete, excess grout, or other foreign material to expose the full face of the grout column. Ensure the reaction system does not contact or interfere with the rock nail anchor reinforcing bar during the test. Conduct the following testing method:

- Apply test loads to rock nail anchors in increments of approximately 10% of the required test load stated on the plans. Hold each load increment long enough to obtain the gauge readings and ensure that the readings have stabilized. Hold the final maximum test load for 10 min.
- Perform initial tensioning to take the slack out of the testing apparatus at 5% of the required test load unless otherwise directed.
- Provide gauges that extend, retract freely, and move smoothly throughout their range. Provide a rigid and secure system to support the gauge independently of the jack or reaction system.
- Verification Test Nail Acceptance Criteria. Unless otherwise shown on the plans, the verification test nail acceptance criteria is:
 - The total creep movement is less than 0.04 in. during the final 10-min. reading increment. If movement exceeds this value, the Engineer may require an additional hold period of up to 60 min. with a maximum 0.08-in. total creep movement including the movement from the original 10-min. hold.
 - The total measured movement at the maximum test load exceeds 80% of the theoretical elastic elongation of the unbonded length of the test nail.
 - A pullout limit state does not occur for the verification load listed on the plans. Pullout limit state is defined at a load level at which the test load cannot be further increased while there is continued movement of the test nail.

Modify construction methods or procedures if the test rock nail anchors fail to provide the minimum pullout capacity specified on the plans. Install and test additional rock nail test anchors until adequate pullout capacity is achieved. Test rock nail anchors, in addition to the number specified on the plans, are subsidiary to this Item.

Install additional rock nail test anchors following the modified construction procedures and test additional rock nail test anchors if the Contractor chooses to modify construction procedures after test rock nail anchors are completed and approved. This additional testing is subsidiary to this Item.

- 4.4.2. **Proof Tests.** Conduct Proof Testing of production rock nails when shown on the plans. The number, length, and target load of nails to be proof loaded must be satisfied and tested according to the following criteria:
- The Engineer will determine the locations of each proof test nail. Completely grout the proof test nails. Proof testing may occur before the placement of pneumatically placed concrete for the temporary face. Leave a sufficiently voided region around the nail head to allow free nail movement if proof testing is to occur after the placement of pneumatically placed concrete for the temporary facing. A minimum of 2 in. clear around the grouted nail is required.

- Use a reaction system as outlined in the Section 411.4.4.1., “Verification Tests.”
- Follow proof nail loading sequence outlined in the Section 411.4.4.1., “Verification Tests,” except use the required proof load stated on the plans.
- Proof Test Nail Acceptance Criteria. Unless otherwise shown on the plans, the proof test nail acceptance criteria is:
 - The total creep movement is less than 0.04 in. during the final 10-min. reading increment. If movement exceeds this value, the Engineer may require an additional hold period of up to 60 min. with a 0.08 in. total creep movement maximum including the movement from the original 10-min. hold.
 - The total measured movement at the maximum test load exceeds 80% of the theoretical elastic elongation of the unbonded length of the test nail.
 - A pullout limit state does not occur for the proof load listed on the plans. Pullout limit state is defined at a load level at which the test load cannot be further increased while there is continued movement of the test nail.
- If the proof test nails fail, the Contractor’s engineer is responsible for redesigning the wall with supplemental rock nail anchors.

5. MEASUREMENT

Rock nail anchors will be measured by the foot of acceptable rock nail anchor in place. The rock nail anchor length measured is the length of the drilled and grouted hole as specified on the plans or modified by the Engineer. Rock nail anchor tests, both verification tests and proof tests, are subsidiary to this Item.

6. PAYMENT

The work performed and materials furnished in accordance with this Item and measured as provided under “Measurement” will be paid for at the unit price bid for “Rock Nail Anchors.” This price is full compensation for materials, equipment, labor, tools, and incidentals.

Item 416

Drilled Shaft Foundations



1. DESCRIPTION

Construct foundations consisting of reinforced or non-reinforced concrete drilled shafts.

2. MATERIALS

Use materials that meet the requirements of the following Items.

- Item 421, "Hydraulic Cement Concrete,"
- Item 440, "Reinforcement for Concrete," and
- Item 448, "Structural Field Welding."

Use concrete for drilled shafts that meets the requirements of Table 1 unless otherwise shown on the plans.

Table 1
Concrete for Drilled Shafts

Drilled Shaft Type	Concrete
Non-reinforced	Class A
Reinforced	Class C
Slurry and underwater concrete placement	Class SS

Use coarse aggregate Grade 4, 5, or 6 for drilled shaft concrete in reinforced drilled shafts. Grade 2 or 3 may be used if the shaft is dry and reinforcing steel has a 5 in. minimum clear spacing.

Use a water-reducing, retarding admixture in accordance with DMS-4640, "Chemical Admixtures for Concrete," in all concrete when using casing that will be pulled or when placing shafts underwater or under slurry.

Use concrete with slump that meets the requirements of Table 2 as determined by Tex-415-A.

Table 2
Slump Requirements

Placement Type	Minimum Acceptable Placement Slump, in.	Recommended Design and Placement Slump, in.	Maximum Acceptable Placement Slump, in.
Dry	5-1/2	6-1/2	7-1/2
Underwater and under slurry	7	8	9

Perform a slump loss test in accordance with Tex-430-A before beginning work when casing is to be pulled or concrete is to be placed underwater or under slurry. Provide concrete that will maintain a slump of at least 4 in. throughout the entire anticipated time of concrete placement. Time of concrete placement is described in Section 416.3.6., "Concrete," and Section 416.3.7., "Additional Requirements for Slurry Displacement or Underwater Concrete Placement Methods." Note the temperature of the concrete mix at the beginning of the slump loss test. Place the concrete if its temperature at the time of placement into the drilled shaft is no more than 10°F higher than the slump loss test temperature. Use ice or other concrete cooling ingredients to lower concrete temperature, or run additional slump loss tests at the higher temperatures. Slump loss testing will be waived if anticipated time of concrete placement is less than 90 minutes.

Use mineral drilling slurry that meets the requirements of Table 3, as determined by Tex-130-E. Determine pH of slurry by Tex-128-E or pH paper strips.

**Table 3
Mineral Slurry Requirements**

Before Introduction into the Excavation			Sampled from the Bottom of the Excavation before Concreting		
Specific Gravity	Sand Content	pH	Specific Gravity	Viscosity (sec.)	Sand Content
≤ 1.10	≤ 1%	8–11	≤ 1.15	≤ 45	≤ 4%

Use mineral slurry consisting of processed bentonite or attapulgite clays mixed with clean fresh water. Do not use partially hydrolyzed polyacrylamide (PHPA) polymeric slurry or any blended mineral-polymer slurry.

If approved, water may be used as the drilling fluid. In this case, all of the provisions of Table 3 must be met except that the maximum specific gravity is not to exceed 1.12.

Sample slurry from the bottom of the hole, before placing concrete, and test it in accordance with Tex-130-E. Use a pump or air lift to remove slurry that does not meet the requirements of Table 3 while adding fresh clean slurry to the top of the hole to maintain the slurry level. Continue this operation until the slurry sampled from the bottom of the hole meets the requirements.

3. CONSTRUCTION

Submit Drilled Shaft installation plan for review no later than one month before drilled shaft construction. Include the following in the plan:

- Name and experience record of the drilled shaft superintendent who will be in charge of drilled shaft operations for this project.
- List of proposed equipment to be used, including cranes, drills, augers, bailing buckets, final cleaning equipment, desanding equipment, slurry pumps, core sampling equipment, tremies or concrete pumps, casing, etc.
- Details of overall construction operation sequence and the sequence of shaft construction in bents or groups.
- Details of shaft excavation methods.
- When the use of slurry is anticipated, details of the slurry mix design and its suitability for the subsurface conditions at the construction site, mixing and storage methods, maintenance methods and disposal procedures.
- Details of methods to clean the shaft excavation.
- Details of reinforcement placement, including support and centralization methods.
- Details of concrete placement, including proposed operational procedures for free fall, tremie or pumping methods.
- Details of casing installation and removal methods.

The installation plan will be reviewed for conformance with the plans, specifications and special provisions. The Contractor will be notified within 14 days of receipt of the installation plan of any additional information required and/or changes necessary to meet the contract requirements. All procedural approvals given will be subject to trial in the field and will not relieve the Contractor of the responsibility to satisfactorily complete the work as detailed in the plans and specifications.

Place the shaft to within the following tolerances:

- Vertical plumbness—1 in. per 10 feet of depth.
- Center of shaft located under column—1 in. of horizontal plan position.
- Center of shaft located under footing—3 in. of horizontal plan position.

Complete the embankment at bridge ends before installing drilled shafts that pass through the fill. Refer to Item 423, "Retaining Walls," for provisions for drilled shafts passing through the structural volume of retaining walls.

- 3.1. **Excavation.** The plans indicate the expected depths and elevations for encountering satisfactory bearing material. Excavate as required for the shafts through all materials encountered to the dimensions and elevations shown on the plans or required by the site conditions. Removal of man-made obstructions not shown on the plans will be paid for in accordance with Article 9.7., "Payment for Extra Work and Force Account Method." Adjust the bottom of the shaft or alter the foundation if satisfactory founding material is not encountered at plan elevation, as approved to satisfactorily comply with design requirements. Blasting is not allowed for excavations.
- Stop drilling if caving conditions are encountered, and adopt a construction method that stabilizes the shaft walls.
- Do not excavate a shaft within 2 shaft diameters (clear) of an open shaft excavation, or one in which concrete has been placed in the preceding 24 hr.
- Dispose of material excavated from shafts and not incorporated into the finished project in accordance with the plans and with federal, state, and local laws.
- Provide suitable access, lighting, and equipment for proper inspection of the completed excavation and checking the dimensions and alignment of shafts excavation.
- 3.2. **Core Holes.** Take cores to determine the character of the supporting materials if directed. Use a method that will result in recovery of an intact sample adequate for judging the character of the founding material. Such cores should be at least 5 ft. deeper than the proposed founding grade or a depth equal to the diameter of the shaft, whichever is greater. Take these cores when the excavation is complete.
- 3.3. **Casing.** Use casing when necessary to prevent caving of the material, to exclude ground water, when slurry is used for hole stabilization, or when required as part of the Contractor's Safety Plan. Provide casing with an outside diameter not less than the specified diameter of the shaft. The portion of shaft below the casing may be as much as 2 in. smaller than the specified shaft diameter. No extra compensation will be made for concrete required to fill an oversized casing or oversized excavation. Use casing strong enough to withstand handling stresses and pressures of concrete and of the surrounding earth or water, and that is watertight, smooth, clean, and free of accumulations of hardened concrete.
- Use construction methods that result in a minimal amount of disturbed soil being trapped outside the casing. This does not apply to temporary undersized casings used to protect workers inside shafts or to drilled shafts designed for point bearing only.
- Leave casing in place only if authorized or shown on the plans. Extract casing only after placing the concrete to an appropriate level. Maintain sufficient concrete in the casing at all times to counteract soil and water pressure. Rotate or move the casing up or down a few inches if necessary before and during concrete placement to facilitate extraction of the casing.
- 3.4. **Requirements for Slurry Displacement Method.** When soil conditions warrant, use the slurry displacement method to construct drilled shafts unless otherwise shown on the plans. Use this method to support the sides of the excavation with processed mineral slurry that is then displaced by concrete to form a continuous concrete shaft.
- Install surface casing to a minimum of 10 ft. below existing ground before introducing slurry. Do not use casing other than surface casing. Do not use surface casing longer than 20 ft. without approval. Do not extract the surface casing until after placing the concrete.
- Pre-mix slurry in a reservoir with enough capacity to fill the excavation and for recovery of the slurry during concrete placement. Do not mix slurry in the shaft excavation or other hole. Allow adequate time for hydration of the slurry before introduction into the excavation.
- Maintain a head of slurry in the shaft excavation at or near ground level or higher, as necessary, to counteract ground water pressure during and after drilling.

Use an air lift or proper size cleanout bucket, just before placing reinforcing steel, to remove any material that may have fallen from the sides of the excavation or accumulated on the bottom after the completion of drilling. Use a cleanout bucket if material is too large to be picked up with an air lift.

Re-process the hole with the auger as directed if concrete placement is not started within 4 hr. of the completion of the shaft excavation. Then clean the bottom with an air lift or cleanout bucket, and check the slurry at the bottom of the hole for compliance with the slurry requirements of Article 416.2., "Materials."

Agitate the congealed slurry to liquefaction if the slurry forms a gel before concrete placement, and whenever directed.

Recover and dispose of all slurry as approved, and in accordance with all federal, state, and local laws. Do not discharge slurry into or in close proximity to streams or other bodies of water.

3.5.

Reinforcing Steel. Completely assemble the cage of reinforcing steel, and place it as a unit immediately before concrete placement. The cage consists of longitudinal bars and lateral reinforcement (spiral reinforcement, lateral ties, or horizontal bands). Connect individual segments with couplers or by lapping steel as approved if overhead obstacles prevent placement of the cage as a single unit.

Extend the reinforcing steel cage as follows if the shaft is lengthened beyond plan length unless directed otherwise.

- Extend the cage to the bottom for shafts supporting structures other than bridges.
- Extend the cage to 25 ft. or to the bottom, whichever is shorter, for bridge shafts with plan lengths less than 25 ft.
- Do not extend the cage for bridge shafts with plan lengths at least 25 ft. that are lengthened less than 33% of plan length.
- Extend the cage as directed for bridge shafts with plan lengths at least 25 ft. that are lengthened more than 33% of plan length.

If the cage does not reach the bottom of the shaft, it may be suspended, or a portion of the longitudinal steel may be extended to support the cage on the bottom of the shaft. Bars used to extend or support the cage may be lap spliced or welded by a qualified welder. Place the extension at the bottom of the shaft.

Tie spiral reinforcement to the longitudinal bars at a spacing no more than 24 in., or as required for a stable cage. Ensure lateral reinforcement is not welded to longitudinal bars unless otherwise shown on the plans.

Center the reinforcing steel cage in the excavation using approved "roller" type centering devices unless otherwise approved. Use concrete or plastic chairs to keep the reinforcing cage off of the bottom of the hole. Use centering devices starting at 1.5 ft. off from the bottom of the cage and spaced vertically at intervals not exceeding 10 ft. Use a minimum of 3 centering devices per level at a spacing not to exceed 30 in. Flat or crescent-shaped centralizers ("sleds") are not allowed.

Support or hold down the cage to control vertical displacement during concrete placement or extraction of the casing. Use support that is concentric with the cage to prevent racking and distortion of the steel.

Check the elevation of the top of the steel cage before and after concrete placement or after casing extraction when casing is used. Downward movement of the steel up to 6 in. per 20 feet of shaft length and upward movement of the steel up to 6 in. total are acceptable.

Maintain the minimum length of steel required for lap with column steel. Use dowel bars if the proper lap length is provided both into the shaft and into the column. Locate and tie all dowel bars into the cage before placing concrete or insert dowel bars into fresh, workable concrete.

Locate and tie anchor bolts when required before placement of concrete. Use templates or other devices to assure accurate placement of anchor bolts.

- 3.6. **Concrete.** Perform all work in accordance with Item 420, "Concrete Substructures." Provide concrete with maximum placement temperatures as specified in Table 4. Provide thermal analysis to show and temperature recording devices to verify maximum core temperature requirements are met as specified in Section 420.4.7.14., "Mass Placements," as directed.

Table 4
Maximum Concrete Placing Temperature

Shaft Size	Mix Design Options 1–5	Mix Design Options 6–8
Diameter < 5 ft.	95°F	95°F
5 ft. ≤ Diameter ≤ 7 ft.	95°F	85°F
7 ft. < Diameter	85°F	75°F

Form portions of drilled shaft that project above natural ground.

Remove loose material and accumulated seep water from the bottom of the excavation before placing concrete. Place concrete using underwater placement methods if water cannot be removed.

Place concrete as soon as possible after all excavation is complete and reinforcing steel is placed. Provide workable concrete that does not require vibrating or rodding. Vibrate formed portions of drilled shafts.

Place concrete continuously for the entire length of the shaft. Limit free fall of concrete to 25 ft. for dry shafts of 24 in. or smaller diameter. Use a suitable tube or tremie to prevent segregation of materials. Use a tube or tremie in sections to provide proper discharge and permit raising as the placement progresses. For dry shafts over 24 in. diameter, concrete can be allowed to free fall an unlimited distance if it does not strike the reinforcing cage or sides of the hole during placement. Provide a hopper with a minimum 3-ft. long drop-tube at the top of the shaft to direct concrete vertically down the center of the shaft when free fall is used. Do not use a shovel or other means to simply deflect the concrete discharge from the truck.

Maintain a sufficient head of concrete for cased shafts at all times above the bottom of the casing to overcome hydrostatic pressure. Extract casing at a slow, uniform rate with the pull in line with the axis of the shaft. Monitor the concrete level in the casing during extraction. Stop the extraction and add concrete to the casing as required to ensure a completely full hole upon casing removal. The elapsed time from the mixing of the first concrete placed into the cased portion of the shaft until the completion of extraction of the casing must not exceed the time for which the concrete maintains a slump of over 4 in. in accordance with Article 416.2., "Materials." Modify the concrete mix, the construction procedures, or both for subsequent shafts if the elapsed time is exceeded.

Cure the top surface and treat any construction joint area in accordance with Item 420, "Concrete Substructures."

- 3.7. **Additional Requirements for Slurry Displacement or Underwater Concrete Placement Methods.** Place concrete on the same day the shaft is excavated and as soon as possible after all excavation is complete and reinforcing steel is placed. Use an air lift or cleanout bucket of the proper size to clean the bottom of the excavation before placing the reinforcing steel cage and concrete. Place concrete through a closed tremie or pump it to the bottom of the excavation. The minimum tremie diameter will be at least 6 times the maximum size of aggregate used in the concrete mix but not less than 10 in. Initially seal the tremie or pump line to positively separate the concrete from the slurry or water. Place concrete continuously from the beginning of placement until the shaft is completed. Keep the tremie full of concrete and well submerged in the previously placed concrete at all times if using a tremie. Raise the tremie as necessary to maintain the free flow of concrete and the stability of any casing used. Keep the discharge tube submerged in the previously placed concrete at all times if using a pump. Place additional concrete to ensure the removal of any contaminated concrete at the top of the shaft. Allow the top portion of concrete to flush completely from the hole at the completion of the pour until there is no evidence of slurry or water contamination. Do not attempt to remove this concrete with shovels, pumps, or other means. Level the top of shaft with hand tools as necessary.

Use a sump or other approved method to channel displaced fluid and concrete away from the shaft excavation. Recover slurry and dispose of it as approved. Do not discharge displaced fluids into or near

streams or other bodies of water. Provide a collar or other means of capturing slurry and the top portion of concrete flushed from the shaft for pours over water.

Remove the tube, reseal it at the bottom, penetrate with the tube into the concrete already placed by at least 5 ft., and recharge it before continuing if concrete placement is interrupted due to withdrawal of the submerged end of the tremie or pump discharge tube before completion. If this condition exists, notify the Engineer and note the elevation and circumstances related to the loss of seal on the drilled shaft log.

The elapsed time from the mixing of the first concrete placed until the completion of concrete placement, including extraction of the casing, must not exceed the time for which the concrete maintains a slump of over 4 in. in accordance with Article 416.2., "Materials." Modify the concrete mix, the construction procedures, or both for subsequent shafts if the elapsed time is exceeded.

- 3.8. **Test Load.** Load test shafts, if required, in accordance with Item 405, "Foundation Load Test."
- 3.9. **Trial Shaft.** When required on the plans, construct trial shafts to the depth and diameter specified on the plans. Trial shafts include: drilling the hole, placement of the rebar cage (unless otherwise stated), and placement of the concrete. When trial shafts are required, delay start of production shafts until successful completion of trial shafts.

4. MEASUREMENT

- 4.1. **Drilled Shaft.** Drilled shaft foundations will be measured by the foot to the bottom of the shaft.
- 4.1.1. **Interior Bents and Piers.** Shafts will be measured from a point approximately 6 in. below the finished earthwork elevation at the center of each shaft, unless specific elevations or dimensions are indicated on the plans or unless otherwise directed to meet unusual conditions. The bent height shown on the plans is for estimating purposes only and does not control the top-of-shaft measurement.
- 4.1.2. **Abutment Bents and Retaining Walls.** Shafts will be measured from the bottom of footing or cap elevation.
- 4.1.3. **Other Non-Bridge Structures.** Shafts, including trial shafts, will be measured from the top of the shaft.
- 4.2. **Core Hole.** Core holes will be measured by each core hole drilled.

5. PAYMENT

The unit prices bid for the various classifications of drilled shafts will be full compensation for excavation; furnishing, placing, and removing casing; furnishing, processing, and recovering slurry; furnishing, and placing reinforcing steel; pumping; furnishing and placing concrete, including additional concrete required to fill an oversize casing or oversize excavation; conducting slump loss tests; backfilling; disposing of cuttings and slurry; and materials, tools, equipment, labor, and incidentals.

When the bottom of a drilled shaft is placed at an elevation below plan grade, no direct payment will be made for extra reinforcement placed to support the cage. The extra reinforcement will be considered subsidiary to the price bid per foot of shaft. No extra payment will be made for casings left in place.

No payment will be made for "Drilled Shaft" until the concrete has been placed.

- 5.1. **Drilled Shaft.** The work performed and materials furnished in accordance with this Item and measured as provided under "Measurement" will be paid for at the unit price bid for "Drilled Shaft," "Drilled Shaft (Non-reinforced)," "Drilled Shaft (Sign Mounts)," "Drilled Shaft (High Mast Pole)," "Drilled Shaft (Roadway Illumination Pole)," or "Drilled Shaft (Traffic Signal Pole)" of the specified diameter, subject to the limitations for overruns authorized by the Engineer given in Section 416.5.1.1., "Overrun."

- 5.1.1. **Overrun.** Payment for individual completed shaft lengths up to and including 5 ft. in excess of the maximum plan length shaft, as defined in Section 416.5.1.2., "Maximum Plan Length Shaft," will be made at the unit price bid per foot of the specified diameter.

Payment for the portion of individual completed shaft length in excess of 5 ft. and up to and including 15 ft. more than the maximum plan length shaft, as defined in this Item, will be made at a unit price equal to 115% of the unit price bid per foot of the specified diameter.

Payment for the portion of individual completed shaft length in excess of 15 ft. more than the maximum plan length shaft, as defined in Section 416.5.1.2., "Maximum Plan Length Shaft," will be made at a unit price equal to 125% of the unit price bid per foot of the specified diameter.

- 5.1.2. **Maximum Plan Length Shaft.** Payment described above is subject to the following provisions for extra depth drilling:

- For bridge structures, the maximum plan length shaft is the maximum length shaft, regardless of diameter, for any drilled shaft on that specific bridge.
- For retaining walls, the maximum plan length shaft is the maximum length shaft, regardless of diameter, for any drilled shaft on that specific retaining wall.
- For overhead sign structures, the maximum plan length shaft is the maximum length shaft, regardless of diameter, for any overhead sign structures included in the Contract.
- For high mast illumination poles, the maximum plan length shaft is the maximum length shaft, regardless of diameter, for any high mast illumination pole included in the Contract.
- For roadway illumination poles, the maximum plan length shaft is the maximum length shaft, regardless of diameter, for any roadway illumination pole included in the Contract.
- For traffic signal poles, the maximum plan length shaft is the maximum length shaft, regardless of diameter, for any traffic signal pole included in the Contract.

- 5.2. **Core Hole.** Core holes will be paid at \$200 each.

Item 420

Concrete Substructures



1. DESCRIPTION

Construct concrete substructures including footings, columns, caps, abutments, piers, culverts, other bridge substructure elements, and other concrete structures as indicated.

2. MATERIALS

- 2.1. **Concrete.** Provide concrete in accordance with Item 421, "Hydraulic Cement Concrete." Provide the class of concrete for each type of structure or unit as shown on the plans or in pertinent governing specifications.
- 2.2. **Grout or Mortar.** Provide grout for dowelling anchors or precast connections in accordance with DMS-4675, "Cementitious Grouts and Mortars for Miscellaneous Applications."
- 2.3. **Latex Curing Materials.** Provide an acrylic-polymer latex admixture (acrylic resin emulsion per DMS-4640, "Chemical Admixtures for Concrete") suitable for producing polymer-modified concrete or mortar. Do not allow latex to freeze.
- 2.4. **Reinforcing Steel.** Provide reinforcing steel in accordance with Item 440, "Reinforcement for Concrete."
- 2.5. **Expansion Joint Material.** Provide materials in accordance with DMS-6310, "Joint Sealants and Fillers."
 - Provide preformed fiber expansion joint material that conforms to the dimensions shown on the plans.
 - Provide preformed bituminous fiber material unless otherwise specified.
 - Provide asphalt board that conforms to dimensions shown on the plans.
 - Provide re-bonded neoprene filler that conforms to the dimensions shown on the plans.
- 2.6. **Waterstop.** Provide rubber or polyvinyl chloride (PVC) waterstops in accordance with DMS-6160, "Water Stops, Nylon Reinforced Neoprene Sheet, and Elastomeric Pads," unless otherwise shown on the plans.
- 2.7. **Curing Materials.** Provide membrane curing compounds in accordance with DMS-4650, "Hydraulic Cement Concrete Curing Materials and Evaporation Retardants."

Provide cotton mats that consist of a filling material of cotton "bat" or "bats" (at least 12 oz. per square yard) completely covered with unsized cloth (at least 6 oz. per square yard) stitched longitudinally with continuous parallel rows of stitching spaced at less than 4 in., or tuft both longitudinally and transversely at intervals less than 3 in. Provide cotton mats that are free from tears and in good general condition. Provide a flap at least 6 in. wide consisting of 2 thicknesses of the covering and extending along 1 side of the mat.

Provide polyethylene sheeting that is at least 4 mils thick and free from visible defects. Provide only clear or opaque white sheeting when the ambient temperature during curing exceeds 90°F or when applicable to control temperature during mass pours.

Provide burlap-polyethylene mats made from burlap impregnated on 1 side with a film of opaque white pigmented polyethylene, free from visible defects. Provide laminated mats that have at least 1 layer of an impervious material such as polyethylene, vinyl plastic, or other acceptable material (either as a solid sheet or impregnated into another fabric) and are free of visible defects.

Provide burlap material which complies with AASHTO M 182, Class 3 (10 oz. per square yard) with the following additions:

- Manila hemp may also be used to make burlap.
- Do not use burlap fabricated from bags.
- Do not use burlap containing any water soluble ingredient which will retard the setting time of concrete.

Provide used burlap complying with the requirements stated above and that has only been used previously for curing concrete. "Like new" cleanliness is not expected, but contamination with any substance foreign to the concrete curing process, such as grease or oil, will be cause for rejection.

- 2.8. **Epoxy.** Provide epoxy materials in accordance with DMS-6100, "Epoxies and Adhesives," unless otherwise specified.

3. EQUIPMENT

- 3.1. **Transporting and Placing Equipment.** Use appropriate transporting and placing equipment such as buckets, chutes, buggies, belt conveyors, pumps, or other equipment as necessary. Ensure concrete is not transported or conveyed through equipment made of aluminum.

Use tremies to control the fall of concrete or for underwater placement. Use tremies that are watertight and of large enough diameter to allow the placement of the concrete but less than 14 in. in diameter. Construct the tremie so the bottom can be sealed and opened once the tremie has been fully charged with concrete for underwater placements.

Use pumps with lines at least 5 in. inside diameter (I.D.) where Grade 2 or smaller coarse aggregate is used, and at least 8 in. I.D. for Grade 1 coarse aggregate.

- 3.2. **Vibrators.** Use immersion-type vibrators for consolidation of concrete. Provide at least 1 standby vibrator for emergency use. Furnish vibrator head covered by a rubberized or elastomeric cover when used near epoxy coated reinforcing steel.
- 3.3. **Temperature Recording Equipment.** Use strip chart temperature recording devices, recording maturity meters in accordance with Tex-426-A, or other approved devices that are accurate to within $\pm 2^\circ\text{F}$ within the range of 32°F to 212°F for mass concrete operations, cold weather placements, and as otherwise specified.
- 3.4. **Artificial Heating Equipment.** Use artificial heating equipment as necessary for maintaining the concrete temperatures as specified in Section 420.4.7.11., "Placing Concrete in Cold Weather."
- 3.5. **Spraying Equipment.** Use mechanically powered pressure sprayers, either air or airless, with appropriate atomizing nozzles for the application of membrane curing. Use hand-pressurized spray equipment with 2 or 3 fan-spray nozzles if approved. Ensure the spray from each nozzle overlaps the spray from adjacent nozzles by approximately 50%.
- 3.6. **Concrete Testing Equipment.** Provide testing equipment for use by the Engineer in accordance with Section 421.3.3., "Testing Equipment."

4. CONSTRUCTION

Obtain approval for proposed construction methods before starting work. Approval of construction methods and equipment does not relieve the Contractor's responsibility for safety or correctness of methods, adequacy of equipment, or completion of work in full accordance with the Contract.

Unless otherwise shown on the plans, it is the Contractor's option to perform testing on structural concrete (structural classes of concrete are identified in Table 8 of Section 421.4.1., "Classification of Concrete Mix Designs,") to determine the in-situ strength to address the schedule restrictions in Section 420.4.1., "Schedule Restrictions." The Engineer may require the Contractor to perform this testing for concrete placed in cold weather. Make enough test specimens for Contractor-performed testing to ensure strength

requirements are met for the operations listed in Section 420.4.1., "Schedule Restrictions." Make at least 1 set of test specimens for each element cast each day. Cure these specimens under the same conditions as the portion of the structure involved for all stages of construction. Ensure safe handling, curing, and storage of all test specimens. Provide testing personnel, and sample and test the hardened concrete in accordance with Section 421.4.8., "Sampling and Testing of Concrete." The maturity method, Tex-426-A, may be used for in-situ strength determination for schedule restrictions if approved. Coring will not be allowed for in-situ strength determination for schedule restrictions. Provide the Engineer the opportunity to witness all testing operations. Report all test results to the Engineer.

If the Contractor does not wish to perform schedule restriction testing, the Engineer's 7-day lab-cured tests, performed in accordance with Article 421.5., "Acceptance of Concrete," will be used for schedule restriction determinations. The Engineer may require additional time for strength gain to account for field curing conditions such as cold weather.

- 4.1. **Schedule Restrictions.** Construct and open completed structures to traffic with the following limitations unless otherwise shown on the plans:
- 4.1.1. **Setting Forms.** Attain at least 2,500 psi compressive strength before erecting forms on concrete footings supported by piling or drilled shafts, or on individual drilled shafts. Erect forms on spread footings and culvert footings after the footing concrete has aged at least 2 curing days as defined in Section 420.4.10., "Curing Concrete." Place concrete only after the forms and reinforcing steel have been inspected by the Engineer.
- Support tie beam or cap forms by falsework on previously placed tie beams only if the tie beam concrete has attained a compressive strength of 2,500 psi and the member is properly supported to eliminate stresses not provided for in the design. Maintain curing as required until completion of the curing period.
- Place superstructure forms or falsework on the substructure only if the substructure concrete has attained a compressive strength of 3,000 psi.
- 4.1.2. **Removal of Forms and Falsework.** Keep in place weight-supporting forms and falsework for bridge components and culvert slabs until the concrete has attained a compressive strength of 2,500 psi in accordance with Section 420.4.11., "Removal of Forms and Falsework." Keep all forms for mass placements in place for 4 days following concrete placement unless otherwise approved based on the outcome of the heat control plan outlined in Section 420.4.7.14., "Mass Placements."
- 4.1.3. **Placement of Superstructure Members.** Erect or place superstructure members or precast substructure members only after the substructure concrete has attained a compressive strength of 3,000 psi.
- 4.1.4. **Opening to Traffic.** Direct traffic culverts may be opened to construction traffic when the design strength specified in Section 421.4.1., "Classification of Concrete Mix Design," has been attained if curing is maintained. Obtain approval before opening direct traffic culverts to the traveling public. Open other noncritical structural and nonstructural concrete for service upon the completion of curing unless otherwise specified or directed.
- 4.1.5. **Post-Tensioned Construction.** Ensure strength requirements on the plans for structural elements designed to be post-tensioned are met for stressing and staged loading of structural elements.
- 4.1.6. **Backfilling.** Backfill in accordance with Section 400.3.3., "Backfill."
- 4.2. **Plans for Falsework and Forms.** Submit plans for falsework and forms for the following items: vertical forms for piers and single column bents; load supporting forms for caps and tie-beams; form attachments for bridges to be widened; and other items as indicated or directed. Provide design calculations when requested. Show all essential details of proposed forms, falsework, and bracing. Have a licensed professional engineer design, seal, and sign these plans. Department approval is not required, except as noted in Table 1 of Item 5, "Control of the Work," when forms or falsework are located such that public safety can be affected, but the Department reserves the right to request modifications to the plans. The Contractor is responsible for the adequacy of these plans. Design job-fabricated formwork assuming a weight of 150 pcf for concrete, and

include a liveload allowance of 50 psf of horizontal surface of the form. Do not exceed 125% of the allowable stresses used by the Department for the design of structures.

- 4.3. **Falsework.** Design and construct falsework to safely carry the maximum anticipated loads, including wind loads, and to provide the necessary rigidity. Consult AASHTO's *Guide Design Specifications for Bridge Temporary Works* and *Construction Handbook for Bridge Temporary Works* for falsework and shoring information not indicated below. Submit details in accordance with Section 420.4.2., "Plans for Falsework and Forms."

Design job-fabricated falsework assuming a weight of 150 pcf for concrete, and include a minimum liveload allowance of 50 psf of horizontal surface of the form. Do not exceed 125% of the allowable stresses used by the Department for the design of structures.

Do not exceed the manufacturer's maximum allowable working loads for moment and shear or end reaction for commercially produced structural units used in falsework. Include a minimum liveload allowance of 35 psf of horizontal form surface in determining the maximum allowable working load for commercially produced structural units.

Provide timber that is sound, in good condition, and free from defects that would impair its strength. Provide timber that meets or exceeds the species, size, and grade requirements in the submitted falsework plans.

Provide wedges made of hardwood or metal in pairs to adjust falsework to desired elevations to ensure even bearing. Do not use wedges to compensate for incorrectly cut bearing surfaces.

Use sills or grillages large enough to support the superimposed load without settlement. Take precautions to prevent settling of the supporting material unless the sills or grillages are founded on solid rock, shale, or other hard materials.

Place falsework that cannot be founded on a satisfactory spread footing on piling or drilled shafts with enough bearing capacity to support the superimposed load without settlement. Drive falsework piling to the required resistance determined by the applicable formula in Item 404, "Driving Piling." Design drilled shafts for falsework to carry the superimposed load using both skin friction and point bearing.

Weld in conformance with Item 448, "Structural Field Welding." Securely brace each falsework bent to provide the stiffness required, and securely fasten the bracing to each pile or column it crosses.

Remove falsework when it is no longer required or as indicated on the submitted falsework plan. Pull or cut off foundations for falsework at least 2 ft. below finished ground level. Completely remove falsework, piling, or drilled shafts in a stream, lake, or bay to the approved limits to prevent obstruction to the waterway.

- 4.4. **Forms.** Submit formwork plans in accordance with Section 420.4.2., "Plans for Falsework and Forms."

- 4.4.1. **General.** Provide forms of either timber or metal except where otherwise specified or permitted.

Design forms for the pressure exerted by a liquid weighing 150 pcf. Take the rate of concrete placement into consideration in determining the depth of the equivalent liquid. Include a minimum liveload allowance of 50 psf of horizontal surface for job-fabricated forms. Do not exceed 125% of the Department's allowable stresses for the design of structures.

Do not exceed the manufacturer's maximum allowable working loads for moment and shear or end reaction for commercially produced structural units used for forms. Include a minimum liveload allowance of 35 psf of horizontal form surface in determining the maximum allowable working load for commercially produced structural units.

Provide steel forms for round columns unless otherwise approved. Refer to Item 427, "Surface Finishes for Concrete," for additional requirements for off-the-form finishes.

Provide commercial form liners for imprinting a pattern or texture on the concrete surface as shown on the plans and specified in Section 427.4.3.5., "Form Liner Finish."

Provide forming systems that are practically mortar-tight, rigidly braced, and strong enough to prevent bulging between supports, and maintain them to the proper line and grade during concrete placement. Maintain forms in a manner that prevents warping and shrinkage. Do not allow offsets at form joints to exceed 1/16 in.

Use only material that is inert, non-biodegradable, and nonabsorptive for forms to be left in place.

Construct all forms to permit their removal without marring or damaging the concrete. Clean all forms and footing areas of any extraneous matter before placing concrete. Provide openings in forms if needed for the removal of laitance or foreign matter.

Treat the facing of all forms with bond-breaking coating of composition that will not discolor or injuriously affect the concrete surface. Take care to prevent coating of the reinforcing steel.

Complete all preparatory work before requesting permission to place concrete.

Cease placement if the forms show signs of bulging or sagging at any stage of the placement, and remove the portion of the concrete causing this condition immediately as directed. Reset the forms and securely brace them against further movement before continuing the placement.

4.4.2.

Timber Forms. Provide properly seasoned, good-quality lumber that is free from imperfections that would affect its strength or impair the finished surface of the concrete. Provide timber or lumber that meets or exceeds the requirements for species and grade in the submitted formwork plans.

Maintain forms or form lumber that will be reused so it stays clean and in good condition. Do not use any lumber that is split, warped, bulged, or marred, or that has defects in any way that will produce inferior work. Promptly remove such lumber from the work.

Provide form lining for all formed surfaces except:

- the inside of culvert barrels, inlets, manholes, and box girders;
- surfaces that are subsequently covered by backfill material or are completely enclosed; and
- any surface formed by a single finished board or by plywood.

Provide form lining of an approved type such as masonite or plywood. Do not provide thin membrane sheeting such as polyethylene sheets for form lining.

Use plywood at least 3/4 in. thick. Place the grain of the face plies on plywood forms parallel to the span between the supporting studs or joists unless otherwise indicated on the submitted form drawings.

Use plywood for forming surfaces that remain exposed that meets the requirements for B-B Plyform Class I or Class II Exterior of the U.S. Department of Commerce Voluntary Product Standard PS 1.

Space studs and joists so the facing form material remains in true alignment under the imposed loads.

Space wales closely enough to hold forms securely to the designated lines, scabbed at least 4 ft. on each side of joints to provide continuity. Place a row of wales near the bottom of each placement.

Place facing material with parallel and square joints, securely fastened to supporting studs.

Place forms with the form panels symmetrical (long dimensions set in the same direction) for surfaces exposed to view and receiving only an ordinary surface finish as defined in Section 420.4.13., "Ordinary Surface Finish." Make horizontal joints continuous.

Make molding for chamfer strips or other uses of materials of a grade that will not split when nailed and can be maintained to a true line without warping. Dress wood molding on all faces. Fill forms at all sharp corners and edges with triangular chamfer strips measuring 3/4 in. on the sides unless otherwise shown on the plans.

Use metal form ties of an approved type or a satisfactory substitute of a type that permits ease of removal of the metal to hold forms in place. Cut back wire ties at least 1/2 in. from the face of the concrete.

Use devices to hold metal ties in place that are able to develop the strength of the tie and adjust to allow for proper alignment.

Entirely remove metal and wooden spreaders that separate the forms as the concrete is being placed.

Provide adequate clean-out openings for narrow walls and other locations where access to the bottom of the forms is not readily attainable.

- 4.4.3. **Metal Forms.** Requirements for timber forms regarding design, mortar-tightness, filleted corners, beveled projections, bracing, alignment, removal, reuse, and wetting also apply to metal forms except metal forms do not require lining unless specifically noted on the plans.

Use form metal thick enough to maintain the true shape without warping or bulging. Countersink all bolt and rivet heads on the facing sides. Design clamps, pins, or other connecting devices to hold the forms rigidly together and to allow removal without damage to the concrete. Use metal forms that present a smooth surface and line up properly. Keep metal free from rust, grease, and other foreign materials.

- 4.5. **Drains.** Install and construct weep holes and roadway drains as shown on the plans.

- 4.6. **Placing Reinforcement and Post-Tensioning.** Place reinforcement as provided in Item 440, "Reinforcement for Concrete." Do not weld reinforcing steel supports to other reinforcing steel except where shown on the plans.

Place post-tensioning ducts, anchorages, and other hardware in accordance with the approved prestressing details and Item 426, "Post-Tensioning." Keep ducts free of obstructions until all post-tensioning operations are complete.

- 4.7. **Placing Concrete.** Give the Engineer sufficient advance notice before placing concrete in any unit of the structure to permit the inspection of forms, reinforcing steel placement, and other preparations.

Do not place concrete when impending weather conditions would impair the quality of the finished work. Place concrete in early morning or at night or adjust the placement schedule for more favorable weather when conditions of wind, humidity, and temperature are such that concrete cannot be placed without the potential for weather-related distress.

Adequately illuminate the entire placement site as approved when mixing, placing, and finishing concrete in non-daylight hours.

Furnish adequate shelter to protect the concrete against damage from rainfall or freezing temperatures as outlined in this Item if changes in weather conditions require protective measures after work starts. Continue operations during rainfall only if approved. Use protective coverings for the material stockpiles. Cover aggregate stockpiles only to the extent necessary to control the moisture conditions in the aggregates.

Allow at least 1 curing day after the concrete has achieved initial set before placing strain on projecting reinforcement to prevent damage to the concrete.

- 4.7.1. **Placing Temperature.** Place concrete according to the following temperature limits for the classes of concrete defined in Section 421.4.1., "Classification of Concrete Mix Designs."

- Place Class C, F, H, K, or SS concrete only when its temperature at time of placement is between 50°F and 95°F. Increase the minimum placement temperature to 60°F if slag cement is used in the concrete.
- Place Class S concrete, used in this Item only as indicated for culvert top slabs, only when its temperature is between 50°F and 85°F. Increase the minimum placement temperature to 60°F if slag cement is used in the concrete.
- Place Class A, B, and D concrete only when its temperature at the time of placement is greater than 50°F.
- Place mass concrete in accordance with Section 420.4.7.14., “Mass Placements,” only when its temperature at the time of placement is between 50°F and 75°F.

4.7.2. **Transporting Time.** Begin the discharge of concrete delivered in truck mixers within the times listed in Table 14 of Item 421, “Hydraulic Cement Concrete.”

4.7.3. **Workability of Concrete.** Place concrete with a slump as specified in Section 421.4.2.5., “Slump.” Water may be added to the concrete before discharging any concrete from the truck to adjust for low slump provided that the maximum mix design water–cement ratio is not exceeded. Mix concrete in accordance with Section 421.4.6., “Mixing and Delivering Concrete,” after introduction of any additional water or chemical admixtures. Do not add water or chemical admixtures after any concrete has been discharged.

4.7.4. **Transporting Concrete.** Transport concrete by buckets, chutes, buggies, belt conveyors, pumps, or other methods.

Protect concrete transported by conveyors from sun and wind to prevent loss of slump and workability. Shade or wrap with wet burlap pipes through which concrete is pumped as necessary to prevent loss of slump and workability.

Arrange and use chutes, troughs, conveyors, or pipes so the concrete ingredients will not be separated. Terminate such equipment in vertical downspouts when necessary to prevent segregation. Extend open troughs and chutes, if necessary, down inside the forms or through holes left in the forms.

Keep all transporting equipment clean and free from hardened concrete coatings. Discharge water used for cleaning clear of the concrete.

4.7.5. **Preparation of Surfaces.** Thoroughly wet all forms and hardened concrete on which concrete is to be placed before placing concrete on them. Remove any remaining puddles of excess water before placing concrete. Provide surfaces that are in a moist, saturated surface-dry condition when concrete is placed on them.

Ensure the subgrade or foundation is moist before placing concrete on grade. Lightly sprinkle the subgrade if dry.

4.7.6. **Expansion Joints.** Construct joints and devices to provide for expansion and contraction in accordance with plan details.

Use light wire or nails to anchor any preformed fiber joint material to the concrete on 1 side of the joint.

Ensure finished joints conform to the plan details with the concrete sections completely separated by the specified opening or joint material.

Remove all concrete within the joint opening soon after form removal and again where necessary after surface finishing to ensure full effectiveness of the joint.

4.7.7. **Construction Joints.** A construction joint is the joint formed by placing plastic concrete in direct contact with concrete that has attained its initial set. Monolithic placement means the manner and sequence of concrete placing does not create a construction joint.

Make construction joints of the type and at the locations shown on the plans. Additional joints in other members are not permitted without approval. Place authorized additional joints using details equivalent to those shown on the plans for joints in similar locations.

Make construction joints square and normal to the forms unless otherwise required. Use bulkheads in the forms for all vertical joints.

Thoroughly roughen the top surface of a concrete placement terminating at a horizontal construction joint as soon as practical after initial set is attained.

Thoroughly clean the hardened concrete surface of all loose material, laitance, dirt, and foreign matter, and saturate it with water. Remove all free water and moisten the surface before concrete or bonding grout is placed against it. Ensure the surface of the existing concrete is in a saturated surface-dry condition (SSD) just before placing subsequent concrete. Wet the existing concrete by ponding water on the surface for 24 hr. before placing subsequent concrete. Use high-pressure water blasting if ponding is not possible to achieve SSD conditions 15 to 30 min. before placing the concrete. An SSD condition is achieved when the surface remains damp when exposed to sunlight for 15 min.

Draw forms tight against the existing concrete to avoid mortar loss and offsets at joints.

Bonding agents are not required unless indicated otherwise. Coat the joint surface with bonding mortar, grout, epoxy, or other material if a bonding agent is required as indicated on the plans. Provide Type V epoxy per DMS-6100, "Epoxies and Adhesives," for bonding fresh concrete to hardened concrete. Place the bonding epoxy on a clean, dry surface, and place the fresh concrete while the epoxy is still tacky. Place bonding mortar or grout on a surface that is SSD, and place the concrete before the bonding mortar or grout dries. Place other bonding agents in accordance with the manufacturer's recommendations.

- 4.7.8. **Handling and Placing.** Minimize segregation of the concrete and displacement of the reinforcement when handling and placing concrete. Produce a uniform, dense compact mass.

Ensure concrete free-falls no more than 5 ft. except in the case of drilled shafts, thin walls such as in culverts, or as allowed by other Items. Remove any hardened concrete splatter ahead of the plastic concrete.

Fill each part of the forms by depositing concrete as near its final position as possible. Do not deposit large quantities of concrete at 1 point and run or move the concrete along to fill the forms.

Deposit concrete in the forms in layers of suitable depth but no more than 36 in. deep unless otherwise permitted.

Avoid cold joints in a monolithic placement. Sequence successive layers or adjacent portions of concrete so they can be vibrated into a homogeneous mass with the previously placed concrete before it sets. Allow no more than 1 hr. to elapse between adjacent or successive placements of concrete when re-vibration of the concrete is shown on the plans except as otherwise allowed by an approved placing procedure. This time limit may be extended by 1/2 hr. if the concrete contains at least the minimum recommended dosage of a Type B or D admixture.

- 4.7.9. **Consolidation.** Carefully consolidate concrete and flush mortar to the form surfaces with immersion type vibrators. Do not use vibrators that operate by attachment to forms or reinforcement except where approved on steel forms.

Vibrate the concrete immediately after deposit. Systematically space points of vibration to ensure complete consolidation and thorough working of the concrete around the reinforcement, embedded fixtures, and into the corners and angles of the forms. Insert the vibrators vertically where possible. Vibrate the entire depth of each lift, allowing the vibrator to penetrate several inches into the preceding lift. Do not use the vibrator to move the concrete to other locations in the forms. Do not drag the vibrator through the concrete. Thoroughly consolidate concrete along construction joints by operating the vibrator along and close to but not against the joint surface. Continue the vibration until the concrete surrounding reinforcements and fixtures is completely

consolidated. Hand-spade or rod the concrete if necessary to ensure flushing of mortar to the surface of all forms.

- 4.7.10. **Installation of Dowels and Anchor Bolts.** Install dowels and anchor bolts by casting them in-place or by grouting with grout, epoxy, or epoxy mortar unless noted otherwise. Form or drill holes for grouting. Follow the manufacturer's recommended installation procedures for pre-packaged grout or epoxy anchor systems. Test anchors if required on the plans or by other Items.

Drill holes for anchor bolts to accommodate the bolt embedment required by the plans. Make holes for dowels at least 12 in. deep unless otherwise shown on the plans. Make the hole diameter at least twice the dowel or bolt diameter, but not exceeding the dowel or bolt diameter plus 1-1/2 in. when using cementitious grout or epoxy mortar. Make the hole diameter 1/16 to 1/4 in. greater than the dowel or bolt diameter when using neat epoxy unless indicated otherwise by the epoxy manufacturer.

Thoroughly clean holes of all loose material, oil, grease, or other bond-breaking substance, and blow them clean with filtered compressed air. Use a wire brush followed by oil-free compressed air to remove all loose material from the holes, repeating as necessary until no more material is removed. Ensure holes are in a surface-dry condition when epoxy type materials are used and in a surface-moist condition when cementitious grout is used. Develop and demonstrate for approval a procedure for cleaning and preparing the holes for installation of the dowels and anchor bolts. Completely fill the void between the hole and dowel or bolt with grouting material. Follow exactly the requirements for cleaning outlined in the product specifications for pre-packaged systems.

Provide hydraulic cement grout for cast-in-place or grouted systems in accordance with DMS-4675, "Cementitious Grouts and Mortars for Miscellaneous Applications." Provide a Type III epoxy per DMS-6100, "Epoxy and Adhesives," when neat epoxy is used for anchor bolts or dowels. Provide Type VIII epoxy per DMS-6100, "Epoxy and Adhesives," when an epoxy grout is used. Provide grout, epoxy, or epoxy mortar as the binding agent unless otherwise indicated on the plans.

Provide other anchor systems as required on the plans.

- 4.7.11. **Placing Concrete in Cold Weather.** Protect concrete placed under weather conditions where weather may adversely affect results. Permission given by the Engineer for placing during cold weather does not relieve the Contractor of responsibility for producing concrete equal in quality to that placed under normal conditions. Remove and replace concrete as directed at the Contractor's expense if it is determined unsatisfactory due to poor conditions.

Do not place concrete in contact with any material coated with frost or with a temperature of 32°F or lower. Do not place concrete when the ambient temperature in the shade is below 40°F and falling unless approved. Place concrete when the ambient temperature in the shade is at least 35°F and rising or above 40°F.

Provide and install recording thermometers, maturity meters, or other suitable temperature measuring devices to verify all concrete is effectively protected as follows:

- Maintain the temperature at all surfaces of concrete in bents, piers, culvert walls, retaining walls, parapets, wingwalls, top slabs of non-direct traffic culverts, and other similar formed concrete at or above 40°F for 72 hr. from the time of placement.
- Maintain the temperature of all other concrete, including the bottom slabs (footings) of culverts, placed on or in the ground above 32°F for 72 hr. from the time of placement.

Use additional covering, insulated forms, or other means and, if necessary, supplement the covering with artificial heating. Avoid applying heat directly to concrete surfaces. Cure as specified in Section 420.4.10., "Curing Concrete," during this period until all requirements for curing have been satisfied.

Have all necessary heating and covering material ready for use before permission is granted to begin placement when impending weather conditions indicate the possible need for temperature protection.

4.7.12. **Placing Concrete in Hot Weather.** Keep the concrete at or below the maximum temperature at time of placement as specified in Section 420.4.7.1., "Placing Temperature." Sprinkle and shade aggregate stockpiles or use ice, liquid nitrogen systems, or other approved methods as necessary to control the concrete temperature.

4.7.13. **Placing Concrete in Water.** Deposit concrete in water only when shown on the plans or with approval. Make forms or cofferdams tight enough to prevent any water current passing through the space in which the concrete is being deposited. Do not pump water during the concrete placing or until the concrete has set for at least 36 hr.

Place the concrete with a tremie or pump, or use another approved method, and do not allow it to fall freely through the water or disturb it after it is placed. Keep the concrete surface level during placement.

Support the tremie or operate the pump so it can be easily moved horizontally to cover all the work area and vertically to control the concrete flow. Submerge the lower end of the tremie or pump hose in the concrete at all times. Use continuous placing operations until the work is complete.

Design the concrete mix in accordance with Item 421, "Hydraulic Cement Concrete," with a minimum cement content of 650 lb. per cubic yard for concrete to be placed under water. Include an anti-washout admixture in the mix design as necessary to produce a satisfactory finished product.

4.7.14. **Mass Placements.** Develop and obtain approval for a heat control plan for monolithic placements designated on the plans as mass concrete to ensure the following during the heat dissipation period:

- the temperature differential between the central core of the placement and the exposed concrete surface does not exceed 35°F and
- the temperature at the central core of the placement does not exceed 160°F.

Use the ConcreteWorks© software available from the Department, or another approved method based on the guidelines in ACI 207, "Mass Concrete," to develop the heat control plan. The Department will make available technical assistance on the use of ConcreteWorks©. Develop the heat control plan using historical temperature ranges for the anticipated time of the mass placement. Re-create the plan if the work schedule shifts by more than one month.

The heat control plan may include a combination of the following elements:

- selection of concrete ingredients including aggregates, gradation, and cement types, to minimize heat of hydration;
- use of ice or other concrete cooling ingredients;
- use of liquid nitrogen dosing systems;
- controlling rate or time of concrete placement;
- use of insulation or supplemental external heat to control heat loss;
- use of supplementary cementing materials;
- use of a cooling system to control the core temperature; or
- vary the duration formwork remains in place.

Furnish and install 2 pairs of temperature recording devices, maturity meters, or other approved equivalent devices. Install devices to measure the surface temperature no more than 3 in. from the surface. Install devices to measure the core temperature a distance of half the least dimension from the nearest surface near the point of maximum predicted heat. Use these devices to simultaneously measure the temperature of the concrete at the core and the surface. Maintain temperature control methods for 4 days unless otherwise approved based on the submitted heat control plan. Do not use maturity meters to predict strength of mass concrete. Revise the heat control plan as necessary to maintain the temperature limitations shown above.

If the core temperature exceeds 160°F, the mass concrete element will be subject to review and acceptance by the Engineer using forensic analyses to determine its potential reduction in service life or performance. Proceed with subsequent construction on the affected element only when notified regarding acceptance.

Repair any resulting cracking if the temperature differential between the central core of the placement and the nearest concrete surface exceeds 35°F at no expense to the Department and revise the heat control plan as necessary to prevent further occurrences.

- 4.7.15. **Placing Concrete in Foundation and Substructure.** Do not place concrete in footings until the depth and character of the foundation has been inspected and permission has been given to proceed.

Place concrete footings upon seal concrete after the cofferdams are free from water and the seal concrete is cleaned. Perform any necessary pumping or bailing during the concreting from a suitable sump located outside the forms.

Construct or adjust all temporary wales or braces inside cofferdams as the work proceeds to prevent unauthorized construction joints.

Omit forms when footings can be placed in a dry excavation without the use of cofferdams, if approved, and fill the entire excavation with concrete to the elevation of the top of footing.

Place concrete in columns monolithically between construction joints unless otherwise directed. Columns and caps or tie beams supported on them may be placed in the same operation or separately. Allow for settlement and shrinkage of the column concrete, if placed in the same operation, by placing it to the lower level of the cap or tie beam, and delay placement between 1 and 2 hr. before proceeding with the cap or tie beam placement.

- 4.7.16. **Placing Concrete in Box Culverts.** Allow between 1 and 2 hr. to elapse where the top slab and walls are placed monolithically in culverts more than 4 ft. in clear height before placing the top slab to allow for settlement and shrinkage in the wall concrete.

Accurately finish the footing slab at the proper time to provide a smooth uniform surface. Finish top slabs that carry direct traffic as specified in Item 422, "Concrete Superstructures." Give top slabs of fill type culverts a float finish.

- 4.8. **Extending Existing Substructures.** Verify pertinent dimensions and elevations of the existing structure before ordering any required materials.

- 4.8.1. **Removal.** Remove portions of the existing structure to the lines and dimensions shown on the plans or as directed. Dispose of these materials as shown on the plans or as directed. Repair any portion of the remaining structure damaged as a result of the construction.

Do not use explosives to remove portions of the existing structure unless approved in writing. Do not use a demolition ball, other swinging weight, or impact equipment unless shown on the plans. Use pneumatic or hydraulic tools for final removal of concrete at the "break" line. Use removal equipment, as approved that will not damage the remaining concrete.

- 4.8.2. **Reuse of Removed Portions of Structure.** Detach and remove all portions of the old structure that are to be incorporated into the extended structure to the lines and details as specified on the plans or as directed. Move the unit to be reused to the new location specified using approved methods. Place the reinforcement and extension concrete according to the plan details.

- 4.8.3. **Splicing Reinforcing Steel.** Splice new reinforcing bars to exposed bars in the existing structure using lap splices in accordance with Item 440, "Reinforcement for Concrete," unless otherwise shown on the plans. The new reinforcing steel does not need to be tied to the existing steel where spacing or elevation does not match that of the existing steel provided the lap length is attained. Weld in accordance with Item 448, "Structural Field Welding," when welded splices are permitted. Install any required dowels in accordance with Section 420.4.7.10., "Installation of Dowels and Anchor Bolts."

- 4.8.4. **Concrete Preparation.** Roughen and clean concrete surfaces that are in contact with new construction before placing forms. Prepare these construction joint surfaces in accordance with Section 420.4.7.7., "Construction Joints."

4.9.

Treatment and Finishing of Horizontal Surfaces. Strike off to grade and finish all unformed upper surfaces. Do not use mortar topping for surfaces constructed under this Section.

Float the surface with a suitable float after the concrete has been struck off.

Slope the tops of caps and piers between bearing areas from the center slightly toward the edge, and slope the tops of abutment and transition bent caps from the backwall to the edge, as directed, so water drains from the surface. Give the concrete a smooth trowel finish. Construct bearing areas for steel units in accordance with Section 441.3.11.6., "Bearing and Anchorage Devices." Give the bearing area under the expansion ends of concrete slabs and slab and girder spans a steel-trowel finish to the exact grades required. Give bearing areas under elastomeric bearing pads or nonreinforced bearing seat buildups a textured, wood float finish. Do not allow the bearing area to vary from a level plane more than 1/16 in. in all directions.

Cast bearing seat buildups or pedestals for concrete units integrally with the cap or a construction joint. Provide a latex-based mortar, an epoxy mortar, or an approved proprietary bearing mortar for bearing seat buildups cast with a construction joint. Mix mortars in accordance with the manufacturer's recommendations. Construct pedestals of Class C concrete, reinforced as shown on the plans or as indicated in Figure 1 and Figure 2. The Engineer of Record will design pedestals higher than 12 in.

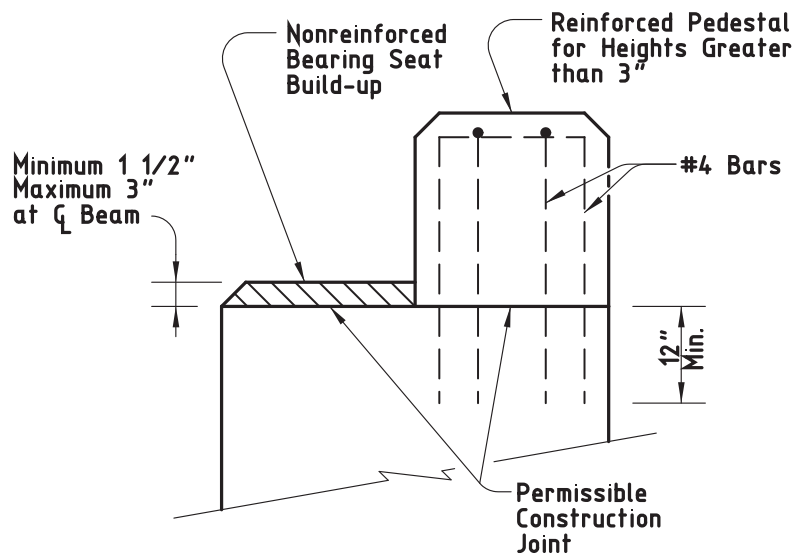

Figure 1
Section through Bearing Seat Buildups

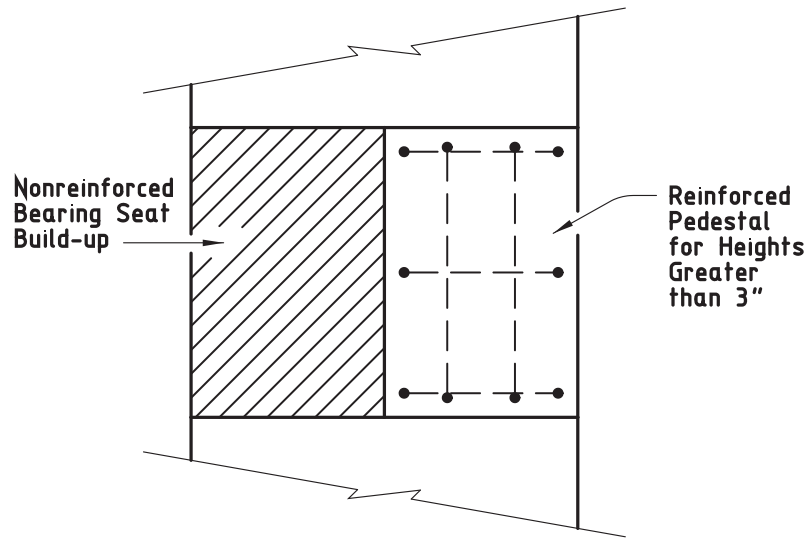

Figure 2
Plan View of Bearing Seat Buildups

- 4.10. **Curing Concrete.** Obtain approval of the proposed curing methods, equipment, and materials before placing concrete. The Engineer may require the same curing methods for like portions of a single structure. Inadequate curing or facilities may delay all concrete placements on the job until remedial action is taken.

A curing day is a calendar day when the temperature, taken in the shade away from artificial heat, is above 50°F for at least 19 hr. or, on colder days if the temperature of all surfaces of the concrete is maintained above 40°F, for the entire 24 hr. The required curing period begins when all concrete has attained its initial set unless indicated otherwise. Tex-440-A may be used to determine when the concrete has attained its initial set.

Cure all concrete for 4 consecutive days except as allowed for the curing options listed below. Use form or membrane curing for vertical surfaces unless otherwise approved. Use only water curing for horizontal surfaces of HPC or mass concrete. Use water or membrane curing for horizontal or unformed surfaces for all other concrete.

Use one of the following curing options for vertical surfaces, unless indicated otherwise.

- Form cure for 48 hr. after placement.
- Form cure for 12 hr. after placement followed by membrane curing.
- For HPC Concrete, form cure for 48 hr. after placement followed by membrane curing.
- For mass concrete, form cure as required by the heat control plan followed by membrane curing if forms are removed before 4 days.

Apply membrane curing, if used, within 2 hr. of form removal.

Use only water curing in accordance with this Section for the top surface of any concrete unit upon which concrete is to be placed and bonded at a later interval (stub walls, caps with backwalls, risers, etc.).

Cure all other concrete as specified in the pertinent Items. Use the following methods for curing concrete, subject to the requirements of this Item.

- 4.10.1. **Form Curing.** When forms are left in intimate contact with the concrete, other curing methods are not required except for exposed surfaces and for cold weather protection. Use another approved curing method if forms are removed before the 4-day required curing period.

- 4.10.2. **Water Curing.** Keep all exposed surfaces of the concrete wet continuously for the required curing time. Use water curing in accordance with concrete mixing water in Section 421.2.5., "Water." Do not use seawater or water that stains or leaves an unsightly residue.
- 4.10.2.1. **Blankets.** Keep the concrete continuously wet by maintaining wet cotton or burlap mats in direct contact with the concrete for the required curing time. Weight the mats adequately to provide continuous contact with all concrete. Cover surfaces that cannot be cured by direct contact with mats, forming an enclosure well anchored to the forms or ground so outside air cannot enter the enclosure. Provide sufficient moisture inside the enclosure to keep all surfaces of the concrete wet.
- 4.10.2.2. **Water Spray.** Overlap sprays or sprinklers to keep all unformed surfaces continuously wet.
- 4.10.2.3. **Ponding.** Cover the surfaces with at least 2 in. of clean granular material, kept wet at all times, or at least 1 in. deep water. Use a dam to retain the water or saturated granular material.
- 4.10.3. **Membrane Curing.** Choose either Type 1-D or Type 2 membrane-curing compound unless otherwise shown on the plans. Use the same type of curing compound on an individual member.

Apply membrane curing just after free moisture has disappeared at a rate of approximately 180 sq. ft. per gallon. Do not spray curing compound on projecting reinforcing steel or concrete that will later form a construction joint. Do not apply membrane curing to dry surfaces. Dampen formed surfaces and surfaces that have been given a first rub so they are moist at the time of application of the membrane.

Leave the film unbroken for the minimum curing period specified when membrane is used for complete curing. Correct damaged membrane immediately by reapplication of membrane. Polyethylene sheeting, burlap-polyethylene mats, or laminated mats in close contact with the concrete surfaces are equivalent to membrane curing.

- 4.11. **Removal of Forms and Falsework.** Remove forms for vertical surfaces after the concrete has aged a minimum of 12 hr. after initial set provided the removal can be done without damage to the concrete unless otherwise directed. Keep forms for mass placements in place for 4 days following concrete placement unless otherwise approved based on the outcome of the heat control plan outlined in Section 420.4.7.14., "Mass Placements."

Leave in place weight-supporting forms and falsework spanning more than 1 ft. for all bridge components and culvert slabs except as directed otherwise until the concrete has attained a compressive strength of 2,500 psi. Remove forms for other structural components as necessary.

Remove inside forms (walls and top slabs) for box culverts and sewers after concrete has attained a compressive strength of 1,800 psi if an approved overhead support system is used to transfer the weight of the top slab to the walls of the box culvert or sewer before removal of the support provided by the forms.

Forms or parts of forms may be removed only if constructed to permit removal without disturbing forms or falsework required to be left in place for a longer period on other portions of the structure.

Remove all metal appliances used inside forms for alignment to a depth of at least 1/2 in. from the concrete surface. Make the appliances so metal may be removed without undue chipping or spalling of the concrete, and so it leaves a smooth opening in the concrete surface when removed. Do not burn off rods, bolts, or ties.

Remove all forms and falsework unless otherwise directed.

- 4.12. **Defective Work.** Repair defective work as soon as possible. Remove and replace at the expense of the Contractor any defect that cannot be repaired to the satisfaction of the Engineer.
- 4.13. **Ordinary Surface Finish.** Apply an ordinary surface finish to all concrete surfaces. Provide flat or textured surfaces as specified with uniform appearance. Address defects and surface irregularities not consistent with the intent of the expected finish by the following:

- Chip away all loose or broken material to sound concrete where porous, spalled, or honeycombed areas are visible after form removal.
- Repair spalls in accordance with the procedures outlined in the *Concrete Repair Manual* available on the Department's website.
- Clean and fill holes or spalls caused by the removal of form ties, etc., with latex grout, cement grout, or epoxy grout as approved. Fill only the holes. Do not blend the patch with the surrounding concrete. On surfaces to receive a rub finish in accordance with Item 427, "Surface Finishes for Concrete," chip out exposed parts of metal chairs to a depth of 1/2 in. and repair the surface.
- Remove all fins, rust staining, runs, drips, or mortar from surfaces that will be exposed. Smooth all form marks and chamfer edges by grinding or dry-rubbing.
- Ensure all repairs are dense, well-bonded, and properly cured. Finish exposed large repairs to blend with the surrounding concrete where a higher class of finish is not specified.

Apply an ordinary surface finish as the final finish to the following exposed surfaces unless noted otherwise:

- inside and top of inlets,
- inside and top of manholes,
- inside of sewer appurtenances, and
- inside of culvert barrels.

Form marks and chamfer edges do not need to be smoothed for the inside of culvert barrels.

5. MEASUREMENT

This Item will be measured by the cubic yard, square yard, foot, square foot, or by each structure.

- 5.1. **General.** Concrete quantities will be based on the dimensions shown on the plans or those established in writing by the Engineer.

In determining quantities, no deductions will be made for chamfers less than 2 in. or for embedded portions of steel or prestressed concrete beams, piling, anchor bolts, reinforcing steel, drains, weep holes, junction boxes, electrical or telephone conduit, ducts and voids for prestressed tendons, or embedded portions of light fixtures.

Variation in concrete headwall quantity incurred when an alternate bid for pipe is permitted will not be cause for payment adjustment.

Quantities revised by a change in design, measured as specified, will be increased or decreased and included for payment.

- 5.2. **Plans Quantity.** Structure elements designated in Table 1 and measured by the cubic yard are plans quantity measurement items. The quantity to be paid for plans quantity items is the quantity shown in the proposal unless modified by Article 9.2., "Plans Quantity Measurement." Additional measurements or calculations will be made if adjustments of quantities are required.

No adjustment will be made for footings or other in-ground elements where the Contractor has been allowed to place concrete in an excavation without forms.

Table 1
Plans Quantity Payment
(Cubic Yard Measurement Only)

Culverts and culvert wing walls	Abutments
Headwalls for pipe	Footings
Retaining walls	Pile bent caps
Inlets and manholes	Post-tensioned elements

Note—Other elements, including pier and bent concrete, may be paid for as “plans quantity” when shown on the plans.

5.3. **Measured in Place.** Items not paid for as “plans quantity” will be measured in place.

6. PAYMENT

The work performed and materials furnished in accordance with this Item and measured as provided under “Measurement” will be paid for at the unit price bid for the class of concrete and element identified and by the special designation when appropriate. This price is full compensation for furnishing, hauling, and mixing concrete materials; furnishing, bending, fabricating, splicing, welding and placing the required reinforcement; clips, blocks, metal spacers, ties, wire, or other materials used for fastening reinforcement in place; furnishing, placing, and stressing post-tensioning system; placing, finishing, and curing concrete; mass placement controls; applying ordinary surface finish; furnishing and placing drains, metal flashing strips, and expansion-joint material; excavation, subgrade preparation; and forms and falsework, equipment, labor, tools, and incidentals.

Price will be adjusted in accordance with Article 421.6., “Measurement and Payment” when required to address non-compliance of project acceptance testing.

Design and installation of foundations for falsework is at the Contractor’s expense.

In addition to the work described above, for extending structures the unit prices bid for the various classifications of concrete shown are full compensation for removing and disposing of, if necessary, the designated portion of the existing structure; removing, stockpiling if necessary, and replacing headwall units for reuse; cleaning, bending, and cutting of exposed reinforcing steel; splicing of new reinforcing steel to existing reinforcing steel; installation of dowels; and cleaning and preparing existing concrete surfaces.

Item 421

Hydraulic Cement Concrete



1. DESCRIPTION

Furnish hydraulic cement concrete for concrete pavements, concrete structures, and other concrete construction.

2. MATERIALS

Use materials from prequalified sources listed on the Department website. Provide coarse and fine aggregates from sources listed in the Department's *Concrete Rated Source Quality Catalog (CRSQC)*. Use materials from non-listed sources only when tested and approved by the Engineer before use. Allow 30 calendar days for the Engineer to sample, test, and report results for non-listed sources. Do not combine approved material with unapproved material.

2.1. **Cement.** Furnish cement conforming to DMS-4600, "Hydraulic Cement."

2.2. **Supplementary Cementing Materials (SCM).**

- **Fly Ash.** Furnish fly ash, ultra-fine fly ash (UFFA), and modified Class F fly ash (MFFA) conforming to DMS-4610, "Fly Ash."
- **Slag Cement.** Furnish Slag Cement conforming to DMS-4620, "Slag Cement."
- **Silica Fume.** Furnish silica fume conforming to DMS-4630, "Silica Fume."
- **Metakaolin.** Furnish metakaolin conforming to DMS-4635, "Metakaolin."

2.3. **Cementitious Material.** Cementitious materials are the cement and supplementary cementing materials used in concrete.

2.4. **Chemical Admixtures.** Furnish admixtures conforming to DMS-4640, "Chemical Admixtures for Concrete."

2.5. **Water.** Furnish mixing and curing water that is free from oils, acids, organic matter, or other deleterious substances. Water from municipal supplies approved by the Texas Department of Health will not require testing. Provide test reports showing compliance with Table 1 before use when using water from other sources.

Water that is a blend of concrete wash water and other acceptable water sources, certified by the concrete producer as complying with the requirements of both Table 1 and Table 2, may be used as mix water. Test the blended water weekly for 4 weeks for compliance with Table 1 and Table 2 or provide previous test results. Then test every month for compliance. Provide water test results upon request.

Table 1
Chemical Limits for Mix Water

Contaminant	Test Method	Maximum Concentration (ppm or mg/L)
Chloride (Cl)	ASTM C114	
Prestressed concrete		500
Bridge decks & superstructure		500
All other concrete		1,000
Sulfate (SO ₄)	ASTM C114	2,000
Alkalies (Na ₂ O + 0.658K ₂ O)	ASTM C114	600
Total solids	ASTM C1603	50,000

Table 2
Acceptance Criteria for Questionable Water Supplies

Property	Test Method	Limits
Compressive strength, min % control at 7 days	ASTM C31, ASTM C39 ^{1,2}	90
Time of set, deviation from control, h:min.	ASTM C403	From 1:00 early to 1:30 later

1. Base comparisons on fixed proportions and the same volume of test water compared to the control mix using 100% potable water or distilled water.
2. Base comparisons on sets consisting of at least 2 standard specimens made from a composite sample.

Do not use mix water that has an adverse effect on the air-entraining agent, on any other chemical admixture, or on strength or time of set of the concrete. Use mixing and curing water free of iron and other impurities that may cause staining or discoloration when using white hydraulic cement.

2.6.

Aggregate.

2.6.1.

Coarse Aggregate. Provide coarse aggregate consisting of durable particles of gravel, crushed blast furnace slag, recycled crushed hydraulic cement concrete, crushed stone, or combinations which are free from frozen material and from injurious amounts of salt, alkali, vegetable matter, or other objectionable material, either free or as an adherent coating. Provide coarse aggregate of uniform quality throughout.

Provide coarse aggregate with the requirements listed in Table 3 unless otherwise shown on the plans.

Table 3
Coarse Aggregate Requirements

Description	Test Method	Limit
Weight of Clay Lumps, % Max	Tex-413-A	0.25
Weight of Shale, % Max		1.0
Weight of Laminated and Friable Particle, % Max		5.0
L.A. Abrasion Wear, % Max	Tex-410-A	40
5-Cycle Magnesium Sulfate Soundness, ^{1,2} non-air-entrained concrete, % Max	Tex-411-A	25
5-Cycle Magnesium Sulfate Soundness, ^{1,3} air-entrained concrete, % Max		18
Loss by Decantation, % Max	Tex-406-A	1.5

1. Recycled crushed hydraulic cement concrete is not subject to 5-cycle magnesium sulfate soundness requirements.
2. Allowed when air-entrained concrete is used at the Contractor's option.
3. Only when air-entrained concrete is required by the plans.

Increase the loss by decantation limit to 3.0% for all classes of concrete and 5.0% for Class A, B, and P if the material finer than the No. 200 sieve is determined to be at least 85% calcium carbonate in accordance with Tex-406-A, Part III, in the case of coarse aggregates made primarily from crushing stone unless otherwise shown on the plans. Provide test results upon request.

Provide coarse aggregate or combination of aggregates conforming to the gradation requirements shown in Table 4 when tested in accordance with Tex-401-A unless otherwise specified.

Table 4
Coarse Aggregate Gradation Chart

Aggregate Grade No. ¹	Maximum Nominal Size	Percent Passing on Each Sieve								
		2-1/2"	2"	1-1/2"	1"	3/4"	1/2"	3/8"	#4	#8
1	2"	100	80-100	50-85		20-40			0-10	
2	1-1/2"		100	95-100		35-70		10-30	0-10	
3	1-1/2"		100	95-100		60-90	25-60		0-10	
4 (57)	1"			100	95-100		25-60		0-10	0-5
5 (67)	3/4"				100	90-100		20-55	0-10	0-5
6 (7)	1/2"					100	90-100	40-70	0-15	0-5
7	3/8"						100	70-95	0-25	
8	3/8"						100	95-100	20-65	0-10

1. Corresponding ASTM C33 gradation shown in parentheses.

2.6.2.

Fine Aggregate. Provide fine aggregate consisting of clean, hard, durable particles of natural, manufactured sand, recycled crushed hydraulic cement concrete, slag, lightweight aggregate, or a combination thereof. Provide fine aggregate free from frozen material and from injurious amounts of salt, alkali, vegetable matter, or other objectionable material.

Provide fine aggregates with the requirements in Table 5 unless otherwise shown on the plans.

Table 5
Fine Aggregate Requirements

Description	Test Method	Limit
Weight of Clay Lumps, % Max	Tex-413-A	0.50
Organic Impurities ¹	Tex-408-A	Color not darker than standard
Sand Equivalent	Tex-203-F	80
Fineness Modulus	Tex-402-A	2.3 to 3.1

1. Only when air-entrained concrete is specified.

Provide fine aggregate or combinations of aggregates conforming to the gradation requirements shown in Table 6 when tested in accordance with Tex-401-A unless otherwise specified.

Table 6
Fine Aggregate Gradation Chart (Grade 1)

Sieve Size	Percent Passing
3/8"	100
#4	95-100
#8	80-100
#16	50-85
#30	25-65
#50	10-35 ¹
#100	0-10
#200	0-3 ²

1. 6-35 when sand equivalent value is greater than 85.

2. 0-6 for manufactured sand.

2.6.3.

Intermediate Aggregate. Provide intermediate aggregate consisting of clean, hard, durable particles of natural, manufactured sand, slag, recycled crushed hydraulic cement concrete, lightweight aggregate, or a combination thereof when optimized aggregate gradation (OAG) concrete is specified or when used at the Contractor's option. Provide intermediate aggregate free from frozen material and injurious amounts of salt, alkali, vegetable matter, or other objectionable material.

Provide intermediate aggregate with the requirements in Table 7.

Table 7
Intermediate Aggregate Requirements

Description	Test Method	Limit
Weight of Clay Lumps, % Max	Tex-413-A	0.50
L.A. Abrasion Wear, ¹ % Max	Tex-410-A	40
5-Cycle Magnesium Sulfate Soundness, ^{1,2,3} non-air-entrained concrete, % Max	Tex-411-A	25
5-Cycle Magnesium Sulfate Soundness, ^{1,2,4} air-entrained concrete, % Max		18
Organic Impurities ⁵	Tex-408-A	Color not darker than standard
Loss by Decantation, ¹ % Max	Tex-406-A	1.5

1. Only applies to the portion retained on the No. 4 sieve, if more than 30% of the intermediate aggregate is retained on the No. 4 sieve.
2. Recycled crushed hydraulic cement concrete is not subject to 5-cycle magnesium sulfate soundness requirements.
3. Allowed when air-entrained concrete is used at the Contractor's option.
4. Only when air-entrained concrete is required by the plans.
5. Only applies to the portion passing the 3/8 in. sieve, if more than 30% of the intermediate aggregate is passing the 3/8 in. sieve.

For the portion retained on the No. 4 sieve, if more than 30% of the intermediate aggregate is retained on the No. 4 sieve, and in the case of aggregates made primarily from crushing stone, unless otherwise shown on the plans, the loss by decantation may be increased to 3.0% for all classes of concrete and 5.0% for Class A, B, and P if the material finer than the No. 200 sieve is determined to be at least 85% calcium carbonate in accordance with Tex-406-A, Part III. Provide test results upon request.

- 2.7. **Mortar and Grout.** Furnish pre-packaged grouts conforming to DMS-4675, "Cementitious Grouts and Mortars for Miscellaneous Applications," when specified for applications other than post-tension grouting.

Section 421.4.2.6., "Mix Design Options," does not apply for mortar and grout.

- 2.8. **Storage of Materials.**

- 2.8.1. **Cement and Supplementary Cementing Materials.** Store all cement and supplementary cementing materials in weatherproof enclosures that will protect them from dampness or absorption of moisture.

When permitted, small quantities of packaged cementitious material may be stored in the open, on a raised platform, and under waterproof covering for up to 48 hr.

- 2.8.2. **Aggregates.** Handle and store concrete aggregates in a manner that prevents contamination with foreign materials. Clear and level the sites for the stockpiles of all vegetation if the aggregates are stored on the ground and do not use the bottom 6-in. layer of aggregate without cleaning the aggregate before use.

Maintain separate stockpiles and prevent intermixing when conditions require the use of 2 or more grades of coarse aggregates. Separate the stockpiles using physical barriers where space is limited. Store aggregates from different sources in different stockpiles unless the Engineer authorizes pre-blending of the aggregates. Minimize segregation in stockpiles. Remix and test stockpiles when segregation is apparent.

Sprinkle stockpiles to control moisture and temperature as necessary. Maintain reasonably uniform moisture content in aggregate stockpiles.

- 2.8.3. **Chemical Admixtures.** Store admixtures in accordance with manufacturer's recommendations and prevent admixtures from freezing.

3. EQUIPMENT

- 3.1. **Concrete Plants and Mixing Equipment.** Except for volumetric stationary plant or truck (auger) mixers, each plant and truck mixer must be currently certified by the National Ready Mixed Concrete Association (NRMCA) or have an inspection report signed and sealed by a licensed professional engineer showing concrete measuring, mixing, and delivery equipment meets all requirements of ASTM C94. A new

certification or signed and sealed report is required every time a plant is moved. Plants with a licensed professional engineer's inspection require re-inspection every 2 yr. Provide a copy of the certification or the signed and sealed inspection report to the Engineer. Remove equipment or facilities from service until corrected when they fail to meet specification requirements.

When allowed on the plans or by the Engineer, for concrete classes not identified as structural concrete in Table 8 or for Class C concrete not used for bridge-class structures, the Engineer may inspect and approve all plants and trucks instead of the NRMCA or non-Department engineer-sealed certifications. The criteria and frequency of Engineer approval of plants and trucks is the same used for NRMCA certification.

Inspect and furnish inspection reports on the condition of blades and fins and their percent wear from the original manufacturer's design for truck mixers and agitators annually. Repair mixing equipment exhibiting 10% or more wear before use. If an inspection within 12 mo. is not practical, a 2-mo. grace period (for a maximum of 14 mo. between inspections) is permitted.

3.1.1. **Scales.** Check all scales before beginning of operations, after each move, or whenever their accuracy or adequacy is questioned, and at least once every 6 mo. Immediately correct deficiencies, and recalibrate. Provide a record of calibration showing scales in compliance with ASTM C94 requirements. Check batching accuracy of volumetric water batching devices at least every 90 days. Check batching accuracy of chemical admixture dispensing devices at least every 6 mo. Perform daily checks as necessary to ensure measuring accuracy.

3.1.2. **Volumetric Mixers.** Provide volumetric mixers with rating plates defining the capacity and the performance of the mixer in accordance with the Volumetric Mixer Manufacturers Bureau or equivalent. Provide volumetric mixers that comply with ASTM C685. Provide test data showing mixers meet the uniformity test requirements of Tex-472-A.

Unless allowed on the plans or by the Engineer, volumetric truck (auger) mixers may not supply classes of concrete identified as structural concrete in Table 8.

3.1.3. **Agitators and Truck and Stationary Mixers.** Provide stationary and truck mixers capable of combining the ingredients of the concrete into a thoroughly mixed and uniform mass and capable of discharging the concrete so at least 5 of the 6 requirements of Tex-472-A are met.

Perform concrete uniformity tests on mixers or agitators in accordance with Tex-472-A as directed, to resolve issues of mix uniformity and mixer performance.

Perform the mixer or agitator uniformity test at the full rated capacity of the equipment. Remove all equipment that fails the uniformity test from service.

Inspect and maintain mixers and agitators. Keep them free of concrete buildup, and repair or replace worn or damaged blades or fins.

Ensure all mixers have a plate affixed showing manufacturer's recommended operating speed and rated capacity for mixing and agitating.

3.2. **Hauling Equipment.** Provide hauling equipment capable of maintaining the mixed concrete in a thoroughly mixed and uniform mass, and discharging the concrete with a satisfactory degree of uniformity.

Provide equipment with smooth, mortar-tight metal containers equipped with gates that prevent accidental discharge of the concrete when using non-agitating equipment for transporting concrete.

Maintain hauling equipment clean and free of built-up concrete.

3.3. **Testing Equipment.** Furnish and maintain the following in accordance with the pertinent test procedure unless otherwise shown on the plans or specified:

- sieves necessary to perform aggregate gradation analysis when optimized aggregate gradation is specified,
- equipment necessary to perform Tex-415-A and Tex-422-A,
- equipment necessary to perform Tex-409-A or Tex-425-A,
- test molds,
- curing facilities,
- maturity meters if used, and
- wheelbarrow or other container acceptable for the sampling of the concrete.

Provide strength-testing equipment when required in accordance with the Contract-controlling test unless shown otherwise.

4. CONSTRUCTION

- 4.1. **Classification of Concrete Mix Designs.** Provide classes of concrete meeting the requirements shown in Table 8.

A higher-strength class of concrete with equal or lower water-to-cementitious material (w/cm) ratio may be substituted for the specified class of concrete when approved.

- 4.2. **Mix Design Proportioning.** Furnish mix designs using ACI 211, Tex-470-A, or other approved procedures for the classes of concrete listed in Table 8 unless a design method is indicated on the plans. Perform mix design proportioning by absolute volume method unless otherwise approved. Perform cement replacement using equivalent weight method unless otherwise approved.

Do not exceed the maximum w/cm ratio listed in Table 8 when designing the mixture.

- 4.2.1. **Cementitious Materials.** Do not exceed 700 lb. of cementitious material per cubic yard of concrete unless otherwise specified or approved.

- Use cement of the same type and from the same source for monolithic placements.
- Do not use supplementary cementing materials when white hydraulic cement is specified.

Table 8
Concrete Classes

Class of Concrete	Design Strength, ¹ Min f'_c (psi)	Max w/cm Ratio	Coarse Aggregate Grades ^{2,3,4}	Cement Types	Mix Design Options	Exceptions to Mix Design Options	General Usage ⁵
A	3,000	0.60	1-4, 8	I, II, I/II, IL, IP, IS, IT, V	1, 2, 4, & 7	When the cementitious material content does not exceed 520 lb./cu. yd., Class C fly ash may be used instead of Class F fly ash.	Curb, gutter, curb & gutter, conc. retards, sidewalks, driveways, back-up walls, anchors, non-reinforced drilled shafts
B	2,000	0.60	2-7				Riprap, traffic signal controller foundations, small roadside signs, and anchors
C ⁶	3,600	0.45	1-6	I, II, I/II, IP, IS, IT, ⁷ V	1-8		Drilled shafts, bridge substructure, bridge railing, culverts except top slab of direct traffic culverts, headwalls, wing walls, inlets, manholes, concrete traffic barrier (cast-in-place)
E	3,000	0.50	2-5	I, II, I/II, IL, IP, IS, IT, ⁷ V	1-8	When the cementitious material content does not exceed 520 lb./cu. yd., Class C fly ash may be used instead of Class F fly ash.	Seal concrete

Concrete Classes

Class of Concrete	Design Strength, ¹ Min f'_c (psi)	Max w/cm Ratio	Coarse Aggregate Grades ^{2,3,4}	Cement Types	Mix Design Options	Exceptions to Mix Design Options	General Usage ⁵
F ⁶	Note ⁸	0.45	2–5	I, II, I/II, IP, IS, IT, ⁷ V			Railroad structures; occasionally for bridge piers, columns, or bents
H ⁶	Note ⁸	0.45	3–6	I, II, I/II, III, IP, IS, IT, ⁷ V	1–5	Do not use Type III cement in mass placement concrete. Up to 20% of blended cement may be replaced with listed SCMs when Option 4 is used for precast concrete.	Precast concrete, post-tension members
S ⁶	4,000	0.45	2–5	I, II, I/II, IP, IS, IT, ⁷ V	1–8		Bridge slabs, top slabs of direct traffic culverts, approach slabs
P	See Item 360, "Concrete Pavement."	0.50	2–3	I, II, I/II, IL, IP, IS, IT, V	1–8	When the cementitious material content does not exceed 520 lb./cu. yd., Class C fly ash may be used instead of Class F fly ash.	Concrete pavement
CO ⁶	4,600	0.40	6	I, II, I/II, IP, IS, IT, ⁷ V	1–8		Bridge deck concrete overlay
LMC ⁶	4,000	0.40	6–8				Latex-modified concrete overlay
SS ⁶	3,600	0.45	4–6				Use a minimum cementitious material content of 658 lb./cu. yd. of concrete.
K ⁶	Note ⁸	0.40	Note ⁸	I, II, I/II, III IP, IS, IT, ⁷ V			Note ⁸
HES	Note ⁸	0.45	Note ⁸	I, IL, II, I/II, III		Mix design options do not apply. 700 lb. of cementitious material per cubic yard limit does not apply.	Concrete pavement, concrete pavement repair
"X" (HPC) 6,9,10	Note ¹¹	0.45	Note ¹¹	I, II, I/II, III IP, IS, IT, ⁷ V	1–5, & 8	Maximum fly ash replacement for Options 1 and 3 may be increased to 45%. Up to 20% of a blended cement may be replaced with listed SCMs for Option 4. Do not use Option 8 for precast concrete.	
"X" (SRC) 6,9,10	Note ¹¹	0.45	Note ¹¹	I/II, II, IP, IS, IT, ⁷ V	1–4, & 7	Do not use Class C Fly Ash Type III-MS may be used where allowed. Type I and Type III cements may be used with Options 1–3, with a maximum w/cm of 0.40. Up to 20% of blended cement may be replaced with listed SCMs when Option 4 is used for precast concrete. Do not use Option 7 for precast concrete.	

- Design strength must be attained within 56 days.
- Do not use Grade 1 coarse aggregate except in massive foundations with 4 in. minimum clear spacing between reinforcing steel bars, unless otherwise permitted. Do not use Grade 1 aggregate in drilled shafts.
- Use Grade 8 aggregate in extruded curbs unless otherwise approved.
- Other grades of coarse aggregate maybe used in non-structural concrete classes when allowed by the Engineer.
- For information only.
- Structural concrete classes.
- Do not use Type IT cements containing > 5% limestone.
- As shown on the plans or specified.
- "X" denotes class of concrete shown on the plans or specified.
- (HPC): High Performance Concrete, (SRC): Sulfate Resistant Concrete.
- Same as class of concrete shown on the plans.

- 4.2.2. **Aggregates.** Recycled crushed hydraulic cement concrete may be used as a coarse or fine aggregate in Class A, B, E, and P concrete. Limit recycled crushed concrete fine aggregate to a maximum of 20% of the fine aggregate.

Use light-colored aggregates when white hydraulic cement is specified.

Use fine aggregate with an acid insoluble residue of at least 60% by weight when tested in accordance with Tex-612-J in all concrete subject to direct traffic.

Use the following equation to determine if the aggregate combination meets the acid insoluble residue requirement when blending fine aggregate or using an intermediate aggregate:

$$\frac{(A_1 \times P_1) + (A_2 \times P_2) + (A_{ia} \times P_{ia})}{100} \geq 60\%$$

where:

A_1 = acid insoluble (%) of fine aggregate 1

A_2 = acid insoluble (%) of fine aggregate 2

A_{ia} = acid insoluble (%) of intermediate aggregate passing the 3/8 in. sieve

P_1 = percent by weight of fine aggregate 1 of the fine aggregate blend

P_2 = percent by weight of fine aggregate 2 of the fine aggregate blend

P_{ia} = percent by weight of intermediate aggregate passing the 3/8 in. sieve

Alternatively to the above equation, blend fine aggregate with a micro-deval loss of less than 12%, when tested in accordance with Tex-461-A, with at least 40% of a fine aggregate with an acid insoluble residue of at least 60%.

- 4.2.3. **Chemical Admixtures.** Do not use Type C, Type E, Type F, or Type G admixtures in Class S bridge deck concrete. Do not use chemical admixtures containing calcium chloride in any concrete.

Use a 30% calcium nitrite solution when a corrosion-inhibiting admixture is required. The corrosion-inhibiting admixture must be set neutral unless otherwise approved. Dose the admixture at the rate of gallons of admixture per cubic yard of concrete shown on the plans.

- 4.2.4. **Air Entrainment.** Use an approved air-entraining admixture when air-entrained concrete is specified, or when an air-entraining admixture is used at the Contractor's option, and do not exceed the manufacturer's recommended dosage. Ensure the minimum entrained air content is at least 3.0% for all classes of concrete except Class P when air-entrained concrete is specified, during trial batch, or when providing previous field data.

- 4.2.5. **Slump.** Provide concrete with a slump in accordance with Table 9 unless otherwise specified. When approved, the slump of a given concrete mix may be increased above the values shown in Table 9 using chemical admixtures, provided the admixture-treated concrete has the same or lower water-to-cementitious material ratio and does not exhibit segregation or excessive bleeding. Request approval to exceed the slump limits in Table 9 sufficiently in advance for proper evaluation by the Engineer.

Perform job-control testing of slump in accordance with Section 421.4.8.3.1., "Job-Control Testing."

Table 9
Placement Slump Requirements

General Usage ¹	Placement Slump Range, ² in.
Walls (over 9 in. thick), caps, columns, piers, approach slabs, concrete overlays	3 to 5
Bridge slabs, top slabs of direct traffic culverts, latex-modified concrete for bridge deck overlays	3 to 5-1/2
Inlets, manholes, walls (less than 9 in. thick), bridge railing, culverts, concrete traffic barrier, concrete pavement (formed), seal concrete	4 to 5-1/2
Precast concrete	4 to 9
Underwater concrete placements	6 to 8-1/2
Drilled shafts, slurry displaced and underwater drilled shafts	See Item 416, "Drilled Shaft Foundations."
Curb, gutter, curb and gutter, concrete retards, sidewalk, driveways, anchors, riprap, small roadside sign foundations, concrete pavement repair, concrete repair	As approved

1. For information only.

2. For fiber reinforced concrete, perform slump before addition of fibers.

4.2.6. **Mix Design Options.**

4.2.6.1. **Option 1.** Replace 20% to 35% of the cement with Class F fly ash.

4.2.6.2. **Option 2.** Replace 35% to 50% of the cement with slag cement or MFFA.

4.2.6.3. **Option 3.** Replace 35% to 50% of the cement with a combination of Class F fly ash, slag cement, MFFA, UFFA, metakaolin, or silica fume; however, no more than 35% may be fly ash, and no more than 10% may be silica fume.

4.2.6.4. **Option 4.** Use Type IP, Type IS, or Type IT cement as allowed in Table 5 for each class of concrete. Up to 10% of a Type IP, Type IS, or Type IT cement may be replaced with Class F fly ash, slag cement, or silica fume. Use no more than 10% silica fume in the final cementitious material mixture if the Type IT cement contains silica fume, and silica fume is used to replace the cement.

4.2.6.5. **Option 5.** Replace 35% to 50% of the cement with a combination of Class C fly ash and at least 6% of silica fume, UFFA, or metakaolin. However, no more than 35% may be Class C fly ash, and no more than 10% may be silica fume.

4.2.6.6. **Option 6.** Use a lithium nitrate admixture at a minimum dosage determined by testing conducted in accordance with Tex-471-A, "Lithium Dosage Determination Using Accelerated Mortar Bar Testing." Before use of the mix, provide an annual certified test report signed and sealed by a licensed professional engineer, from a laboratory on the Department's MPL, certified by the Construction Division as being capable of testing according to Tex-471-A, "Lithium Dosage Determination Using Accelerated Mortar Bar Testing."

4.2.6.7. **Option 7.** Ensure the total alkali contribution from the cement in the concrete does not exceed 3.5 lb. per cubic yard of concrete when using hydraulic cement not containing SCMs calculated as follows:

$$\text{lb. alkali per cu. yd.} = \frac{(\text{lb. cement per cu. yd.}) \times (\% \text{ Na}_2\text{O equivalent in cement})}{100}$$

In the above calculation, use the maximum cement alkali content reported on the cement mill certificate.

4.2.6.8. **Option 8.** Perform annual testing as required for any deviations from Options 1–5 or use mix design options listed in Table 10. Laboratories performing ASTM C1260, ASTM C1567, and ASTM C1293 testing must be listed on the Department's MPL. Before use of the mix, provide a certified test report signed and sealed by a licensed professional engineer demonstrating the proposed mixture conforms to the requirements of Table 10.

Provide a certified test report signed and sealed by a licensed professional engineer, when HPC is required, and less than 20% of the cement is replaced with SCMs, demonstrating ASTM C1202 test results indicate the permeability of the concrete is less than 1,500 coulombs tested immediately after either of the following curing schedules:

- Moisture cure specimens 56 days at 73°F.
- Moisture cure specimens 7 days at 73°F followed by 21 days at 100°F.

Table 10
Option 8 Testing and Mix Design Requirements

Scenario	ASTM C1260 Result		Testing Requirements for Mix Design Materials or Prescriptive Mix Design Options ¹
	Mix Design Fine Aggregate	Mix Design Coarse Aggregate	
A	> 0.10%	> 0.10%	Determine the dosage of SCMs needed to limit the 14-day expansion of each aggregate ² to 0.08% when tested individually in accordance with ASTM C1567; or Use a minimum of 40% Class C fly ash with a maximum CaO ³ content of 25%.
B	≤ 0.10%	≤ 0.10%	Use a minimum of 40% Class C fly ash with a maximum CaO ³ content of 25%; or Use any ternary combination which replaces 35% to 50% of cement.
	≤ 0.10%	ASTM C1293 1 yr. Expansion ≤ 0.04%	Use a minimum of 20% of any Class C fly ash; or Use any ternary combination which replaces 35% to 50% of cement.
C	≤ 0.10%	> 0.10%	Determine the dosage of SCMs needed to limit the 14-day expansion of coarse and intermediate ² aggregate to 0.08% when tested individually in accordance with ASTM C1567; or Use a minimum of 40% Class C fly ash with a maximum CaO ³ content of 25%.
D	> 0.10%	≤ 0.10%	Use a minimum of 40% Class C fly ash with a maximum CaO ³ content of 25%; or Use any ternary combination which replaces 35% to 50% of cement.
	> 0.10%	ASTM C1293 1 yr. Expansion ≤ 0.04%	Determine the dosage of SCMs needed to limit the 14-day expansion of fine aggregate to 0.08% when tested in accordance with ASTM C1567.

1. Do not use Class C fly ash if the ASTM C1260 value of the fine, intermediate, or coarse aggregate is 0.30% or greater, unless the fly ash is used as part of a ternary system.
2. Intermediate size aggregates will fall under the requirements of mix design coarse aggregate.
3. Average the CaO content from the previous ten values as listed on the mill certificate.

4.2.7. **Optimized Aggregate Gradation (OAG) Concrete.** The gradation requirements in Table 3 and Table 4 do not apply when OAG concrete is specified or used by the Contractor unless otherwise shown on the plans. Use Tex-470-A to establish the optimized aggregate gradation. Use at least 420 lb. per cubic yard of cementitious material when OAG concrete is used unless otherwise approved. Use a coarse aggregate with a maximum nominal size of 1-1/2 in. for Class P concrete. Use a coarse aggregate for all other classes of concrete with a maximum nominal size not larger than:

- 1/5 the narrowest dimension between sides of forms, or
- 1/3 the depth of slabs, or
- 3/4 the minimum clear spacing between individual reinforcing bars or wires, bundles of bars, individual tendons, bundled tendons, or ducts.

Make necessary adjustments to individual aggregate stockpile proportions during OAG concrete production when the gradation deviates from the optimized gradation requirements.

4.2.8. **Self-Consolidating Concrete (SCC).** Provide SCC meeting the following requirements shown in Table 11 when approved for use in precast concrete. Use concrete with a slump flow that can be placed without vibration and will not segregate or excessively bleed.

Request approval to exceed the slump flow limits sufficiently in advance for proper evaluation by the Engineer.

Table 11
Mix Design Requirements for SCC

Tests	Test Method	Acceptable Limits
Slump Flow for Precast Concrete	ASTM C1611	22 to 27 ¹
T ₅₀ , sec	ASTM C1611	2 to 7
VSI Rating	ASTM C1611	0 or 1
Passing Ability, in.	ASTM C1621	≤ 2
Segregation Column, %	ASTM C1610	≤ 10
Bleeding, %	ASTM C232	≤ 2.5

1. These slump flow limits are generally acceptable for most applications. However, slump flow limits may be adjusted during mix design approval process and when approved by the Engineer.

- 4.3. **Concrete Trial Batches.** Perform preliminary and final trial batches when required by the plans, or when previous satisfactory field data is not available. Submit previous satisfactory field data to the Engineer showing the proposed mix design conforms to specification requirements when trial batches are not required and before concrete is placed.

Perform preliminary and final trial batches for all self-consolidating concrete mix designs.

- 4.3.1. **Preliminary Trial Batches.** Perform all necessary preliminary trial batch testing when required, and provide documentation including mix design, material proportions, and test results substantiating the mix design conforms to specification requirements.

- 4.3.2. **Final Trial batches.** Make all final trial batches using the proposed ingredients in a mixer that is representative of the mixers to be used on the job when required. Make the batch size at least 50% of the mixer's rated capacity. Perform fresh concrete tests for air content and slump, and make, cure, and test strength specimens for compliance with specification requirements. Test at least one set of design strength specimens, consisting of 2 specimens per set, at 7-day, 28-day, and at least one additional age unless otherwise directed. Before placing, provide the Engineer the option of witnessing final trial batches, including the testing of the concrete. If not provided this option, the Engineer may require additional trial batches, including testing, before the concrete is placed.

Conduct all testing listed in Table 11 when performing trial batches for self-consolidating concrete. Make an additional mixture with 3% more water than the preliminary trial batch. Make necessary adjustments to the mix design if this additional mixture does not meet requirements of Table 11. Cast and evaluate mock-ups for precast concrete that are representative of the actual product as directed. Provide the Engineer the option of witnessing final trial batches, including the testing of the concrete and the casting of the mock-ups before placement. If not provided this option, the Engineer may require additional trial batches, including testing and mock-ups, before the concrete is placed.

Establish 7-day compressive strength target values using the following formula for each Class A, B, and E concrete mix designs to be used:

$$\text{Target value} = \text{Minimum design strength} \times \frac{7\text{-day avg. trial batch strength}}{28\text{-day avg. trial batch strength}}$$

Submit previous satisfactory field data, data from a new trial batch, or other evidence showing the change will not adversely affect the relevant properties of the concrete when changes are made to the type, brand, or source of aggregates, cement, SCM, water, or chemical admixtures. Submit the data for approval before making changes to the mix design. A change in vendor does not necessarily constitute a change in materials or source. The Engineer may waive new trial batches when there is a prior record of satisfactory performance with the ingredients. During concrete production, dosage changes of chemical admixtures used in the trial batches will not require a re-evaluation of the mix design.

The Contractor has the option of performing trial batches in conjunction with concrete placements except for SCC mixtures, when new trial batches are required during the course of the project. If the concrete fails to meet any requirement, the Engineer will determine acceptability and payment adjustments.

Establish the strength–maturity relationship in accordance with Tex-426-A when the maturity method is specified or permitted. When using the maturity method, any changes in any of the ingredients, including changes in proportions, will require the development of a new strength–maturity relationship for the mix.

4.3.3. **Mix Design of Record.** Once a trial batch or previously satisfactory field data substantiates the mix design, the proportions and mixing methods used become the mix design of record. Do not exceed mix design water-to-cementitious material ratio.

4.4. **Production Testing.**

4.4.1. **Aggregate Moisture Testing.** Determine moisture content per Tex-409-A or Tex-425-A for coarse, intermediate, and fine aggregates at least twice a week, when there is an apparent change, or for new shipments of aggregate. When aggregate hoppers or storage bins are equipped with properly maintained electronic moisture probes for continuous moisture determination, moisture tests per Tex-409-A or Tex-425-A are not required. Electronic moisture probes, however, must be verified at least every 90 days against Tex-409-A and be accurate to within 1.0% of the actual moisture content.

When producing SCC, and when aggregate hoppers or storage bins are not equipped with electric moisture probes, determine the moisture content of the aggregates before producing the first concrete batch each day. Thereafter, determine the moisture content every 4 hr. or when there is an apparent change while SCC is being produced.

4.4.2. **Aggregate Gradation Testing.** Perform a sieve analysis in accordance with Tex-401-A on each stockpile used in the blend at least one day before producing OAG concrete when producing optimized aggregate gradation concrete. Perform sieve analysis on each stockpile after every 10,000 cubic yards of OAG concrete produced. Provide sieve analysis data to the Engineer.

4.5. **Measurement of Materials.**

4.5.1. **Non-Volumetric Mixers.** Measure aggregates by weight. Correct batch weight measurements for aggregate moisture content. Measure mixing water, consisting of water added to the batch, ice added to the batch, water occurring as surface moisture on the aggregates, and water introduced in the form of admixtures, by volume or weight. Measure ice by weight. Measure cement and supplementary cementing materials in a hopper and on a separate scale from those used for other materials. Measure the cement first when measuring the cumulative weight. Measure concrete chemical admixtures by weight or volume. Measure batch materials within the tolerances of Table 12.

Table 12
Mix Design Batching Tolerances—Non-Volumetric Mixers

Material	Tolerance (%)
Cement, wt.	-1 to +3
SCM, wt.	-1 to +3
Cement + SCM (cumulative weighing), wt.	-1 to +3
Water, wt. or volume	±3 ¹
Fine aggregate, wt.	±2
Coarse aggregate, wt.	±2
Fine + coarse aggregate (cumulative weighing), wt.	±1
Chemical admixtures, wt. or volume	±3

1. Allowable deviation from target weight not including water withheld or moisture in the aggregate. The Engineer will verify the water-to-cementitious material ratio is within specified limits.

Ensure the quantity measured, when measuring cementitious materials at less than 30% of scale capacity, is accurate to not less than the required amount and not more than 4% in excess. Ensure the cumulative quantity, when measuring aggregates in a cumulative weigh batcher at less than 30% of the scale capacity,

is measured accurate to $\pm 0.3\%$ of scale capacity or $\pm 3\%$ of the required cumulative weight, whichever is less.

Measure cement in number of bags under special circumstances when approved. Use the weights listed on the packaging. Weighing bags of cement is not required. Ensure fractional bags are not used except for small hand-mixed batches of approximately 5 cu. ft. or less and when an approved method of volumetric or weight measurement is used.

- 4.5.2. **Volumetric Mixers.** Provide an accurate method of measuring all ingredients by volume, and calibrate equipment to assure correct measurement of materials within the specified tolerances. Base tolerances on volume–weight relationship established by calibration, and measure the various ingredients within the tolerances of Table 13. Correct batch measurements for aggregate moisture content.

Table 13
Mix Design Batching Tolerances—Volumetric Mixers

Material	Tolerance
Cement, wt. %	0 to +4
SCM, wt. %	0 to +4
Fine aggregate, wt. %	± 2
Coarse aggregate, wt. %	± 2
Admixtures, wt. or volume %	± 3
Water, wt. or volume %	± 1

- 4.6. **Mixing and Delivering Concrete.**

- 4.6.1. **Mixing Concrete.** Operate mixers and agitators within the limits of the rated capacity and speed of rotation for mixing and agitation as designated by the manufacturer of the equipment. Provide concrete in a thoroughly mixed and uniform mass with a satisfactory degree of uniformity when tested in accordance with Tex-472-A.

Do not top-load new concrete onto returned concrete.

Adjust mixing times and batching operations as necessary when the concrete contains silica fume to ensure the material is completely and uniformly dispersed in the mix. The dispersion of the silica fume within the mix will be verified by the Construction Division, Materials and Pavements Section, using cylinders made from trial batches. Make necessary changes to the batching operations, if uniform dispersion is not achieved, until uniform and complete dispersion of the silica fume is achieved.

Mix concrete by hand methods or in a small motor-driven mixer when permitted, for small placements of less than 2 cu. yd. For such placements, proportion the mix by volume or weight.

- 4.6.2. **Delivering Concrete.** Deliver concrete to the project in a thoroughly mixed and uniform mass, and discharge the concrete with a satisfactory degree of uniformity. Conduct testing in accordance with Tex-472-A when there is a reason to suspect the uniformity of concrete and as directed.

Maintain concrete delivery and placement rates sufficient to prevent cold joints.

Adding chemical admixtures or the portion of water withheld is only permitted at the jobsite, under the supervision of the Engineer, to adjust the slump or slump flow of the concrete. Do not add water or chemical admixtures to the batch after more than an amount needed to conduct slump testing has been discharged. Turn the drum or blades at least 30 additional revolutions at mixing speed to ensure thorough and uniform mixing of the concrete. When this water is added, do not exceed the approved mix design water-to-cementitious material ratio.

Before unloading, furnish the delivery ticket for the batch of concrete containing the information required on Department Form 596, "Concrete Batch Ticket." The Engineer will verify all required information is provided on the delivery tickets. The Engineer may suspend concrete operations until the corrective actions are

implemented if delivery tickets do not provide the required information. The Engineer will verify the design water-to-cementitious material ratio is not exceeded.

Begin the discharge of concrete delivered in truck mixers within the times listed in Table 14. Concrete may be discharged after these times provided the concrete temperature and slump meet the requirements listed in this Item and other pertinent Items. Perform these tests with certified testing personnel per Section 421.4.8.1., "Certification of Testing Personnel." Provide the Engineer the option of witnessing testing of the concrete. If not provided this option, the Engineer may require additional testing before the concrete is placed.

Table 14
Concrete Discharge Times

Fresh Concrete Temperature, °F	Max Time After Batching for Concrete Not Containing Type B or D Admixtures, min.	Max Time After Batching for Concrete Containing Type B or D Admixtures, ¹ min.
90 and above	45	75
75 ≤ T < 90	60	90
T < 75	90	120

- Concrete must contain at least the minimum manufacturer's recommended dosage of Type B or D admixture.

4.7. **Placing, Finishing, and Curing Concrete.** Place, finish, and cure concrete in accordance with the pertinent Items.

4.8. **Sampling and Testing of Concrete.** Unless otherwise specified, all fresh and hardened concrete is subject to testing as follows:

4.8.1. **Certification of Testing Personnel.** Contractor personnel performing testing must be either ACI-certified or qualified by a Department-recognized equivalent written and performance testing program for the tests being performed. Personnel performing these tests are subject to Department approval. Use of a commercial laboratory is permitted at the Contractor's option. All personnel performing testing using the maturity method must be qualified by a training program recognized by the Department before using this method on the job.

4.8.2. **Fresh Concrete.** Provide safe access and assistance to the Engineer during sampling. Fresh concrete will be sampled for testing at the discharge end if using belt conveyors or pumps. When it is impractical to sample at the discharge end, a sample will be taken at the time of discharge from the delivery equipment and correlation testing will be performed and documented to ensure specification requirements are met at the discharge end.

4.8.3. **Testing of Fresh Concrete.** Test for the fresh properties listed in Table 15.

Table 15
Fresh Concrete Tests

Tests	Test Methods
Slump ¹	Tex-415-A
Temperature ¹	Tex-422-A
Air Content ^{1,2}	Tex-414-A, Tex-416-A or ASTM C457

- Job-control testing performed by the Contractor.
- Only required when air-entrained concrete is specified on the plans.

Concrete with a slump lower than the minimum placement slump in Table 9 after the addition of all water withheld, or concrete exhibiting segregation and excessive bleeding will be rejected.

4.8.3.1. **Job-Control Testing.** Perform job-control testing as specified in Table 16 unless otherwise specified. Provide the Engineer the opportunity to witness the testing. The Engineer may require a retest if not given the opportunity to witness. Immediately notify the Engineer of any nonconformity issues. Furnish a copy of all test results to the Engineer daily.

Table 16
Job-Control Testing Frequencies

Concrete Placements	Frequency
Bridge Deck Placements	Test the first few loads, then every 60 cu. yd. or fraction thereof.
All Other Structural Class Concrete Placements	One test every 60 cu. yd. or fraction thereof per class per day.
Non-Structural Class Concrete Placements	One test every 180 cu. yd. or fraction thereof.

Immediately resample and retest the concrete slump when the concrete exceeds the slump range at time of placement. If the concrete exceeds the slump range after the retest, and is used at the Contractor's option, the Engineer will make strength specimens as specified in Article 421.5., "Acceptance of Concrete."

- 4.8.3.2. **Strength Specimen Handling.** Remove specimens from their molds and deliver Department test specimens to curing facilities within 24 to 48 hr. after molding, in accordance with pertinent test procedures unless otherwise shown on the plans or directed. Clean and prepare molds for reuse if necessary.

5. ACCEPTANCE OF CONCRETE

The Engineer will sample and test the fresh and hardened concrete for acceptance. The test results will be reported to the Contractor and the concrete supplier. Investigate the quality of the materials, the concrete production operations, and other possible problem areas to determine the cause for any concrete that fails to meet the required strengths as outlined below. Take necessary actions to correct the problem including redesign of the concrete mix. The Engineer may suspend all concrete operations under the pertinent Items if the Contractor is unable to identify, document, and correct the cause of the low strengths in a timely manner. Resume concrete operations only after obtaining approval for any proposed corrective actions. Concrete failing to meet the required strength as outlined below will be evaluated using the procedures listed in Article 421.6., "Measurement and Payment."

- 5.1. **Structural Class of Concrete.** For concrete classes identified as structural concrete in Table 8, the Engineer will make and test 7-day and 28-day specimens. Acceptance will be based on attaining the design strength given in Table 8.
- 5.2. **Class P and Class HES.** The Engineer will base acceptance in accordance with Item 360, "Concrete Pavement," and Item 361, "Repair of Concrete Pavement."
- 5.3. **All Other Classes of Concrete.** For concrete classes not identified as structural concrete in Table 8, the Engineer will make and test 7-day specimens. The Engineer will base acceptance on the 7-day target value established in accordance with Section 421.4.3., "Concrete Trial Batches."

6. MEASUREMENT AND PAYMENT

The work performed, materials furnished, equipment, labor, tools, and incidentals will not be measured or paid for directly but will be subsidiary to pertinent Items.

The following procedure will be used to evaluate concrete where one or more project acceptance test specimens fail to meet the required design strength specified in this Item or on the plans:

- The concrete for a given placement will be considered structurally adequate and accepted at full price if the average of all test results for specimens made at the time of placement meets the required design strength provided no single test result is less than 85% of the required design strength.
- The Engineer will perform a structural review of the concrete to determine its adequacy to remain in service if the average of all test results for specimens made at the time of placement is less than the required design strength or if any test results are less than 85% of the required design strength. If the in-situ concrete strength is needed for the structural review, take cores at locations designated by the

Engineer in accordance with Tex-424-A. The Engineer will test the cores. The coring and testing will be at the Contractor's expense.

- If all of the tested cores meet the required design strength, the concrete will be paid for at full price.
- If any of the tested cores do not meet the required design strength, but the average strength attained is determined to be structurally adequate, the Engineer will determine the limits of the payment adjustment using the following formula:

$$A = B_p \left[-5.37 \left(\frac{S_a}{S_s} \right)^2 + 11.69 \left(\frac{S_a}{S_s} \right) - 5.32 \right]$$

where:

A = Amount to be paid per unit of measure for the entire placement in question

S_a = Actual average strength from cylinders or cores. Use values from cores, if taken.

S_s = Minimum required strength (specified)

B_p = Unit Bid Price

- If the structural review determines the concrete is not adequate to remain in service, the Engineer will determine the limits of the concrete to be removed.
- The decision to reject structurally inadequate concrete or to apply the payment adjustment factor will be made no later than 56 days after placement.

Item 422

Concrete Superstructures



1. DESCRIPTION

Construct reinforced concrete bridge slabs, decks, flat slabs, slab and girder units (pan formed), approach slabs, or other bridge superstructure elements as indicated.

2. MATERIALS

2.1. **Concrete.** Provide concrete conforming to Item 421, "Hydraulic Cement Concrete." Provide Class S or S (HPC) concrete for all cast-in-place concrete unless otherwise shown on the plans. Provide the class of concrete for precast components indicated on the plans or in pertinent governing Items.

2.2. **Reinforcing Steel.** Provide reinforcing steel in accordance with Item 440, "Reinforcement for Concrete."

2.3. **Structural Grout.** Provide grout in accordance with DMS-4675, "Cementitious Grouts and Mortars for Miscellaneous Applications" or as indicated on the plans.

2.4. **Expansion Joint Material.** Provide materials in accordance with DMS-6310, "Joint Sealants and Fillers."

- Provide preformed bituminous fiber expansion joint material unless indicated otherwise.
- Provide a Class 4, 5, or 7 low-modulus silicone sealant unless otherwise directed.
- Provide asphalt board that conforms to dimensions shown on the plans.
- Provide re-bonded neoprene filler that conforms to the dimensions shown on the plans.

2.5. **Foam Bedding Strips for Prestressed Concrete Panels.** Use extruded polystyrene conforming to ASTM C578, Type VI (40 psi compressive strength) or as specified.

Provide a manufacturer's certification or data sheet stating the foam meets these requirements. Use an adhesive or bonding agent compatible with polystyrene as recommended by the polystyrene manufacturer.

2.6. **Evaporation Retardants.** Provide evaporation retardants in accordance with DMS-4650, "Hydraulic Cement Concrete Curing Materials and Evaporation Retardants."

2.7. **Curing Materials.** Provide membrane curing compounds in accordance with DMS-4650, "Hydraulic Cement Concrete Curing Materials and Evaporation Retardants."

Provide cotton mats that consist of a filling material of cotton "bat" or "bats" (at least 12 oz. per square yard) completely covered with unsized cloth (at least 6 oz. per square yard) stitched longitudinally with continuous parallel rows of stitching spaced at less than 4 in., or tuft both longitudinally and transversely at intervals less than 3 in. Provide cotton mats that are free from tears and in good general condition. Provide a flap at least 6 in. wide consisting of 2 thicknesses of the covering and extending along one side of the mat.

Provide polyethylene sheeting that is at least 4 mils thick and free from visible defects. Provide opaque white sheeting when the ambient temperature during curing exceeds 90°F.

Provide burlap-polyethylene mats made from burlap impregnated on one side with a film of opaque white pigmented polyethylene, free from visible defects. Provide laminated mats that have at least one layer of an impervious material such as polyethylene, vinyl plastic, or other acceptable material (either as a solid sheet or impregnated into another fabric) and are free of visible defects.

Provide burlap material which complies with AASHTO M 182, Class 3 (10 oz. per square yard) with the following additions:

- Manila hemp may also be used to make burlap.
- Do not use burlap fabricated from bags.
- Do not use burlap containing any water soluble ingredient which will retard the setting time of concrete.

Provide used burlap complying with the requirements stated above, and that only has been used previously for curing concrete. "Like new" cleanliness is not expected, but contamination with any substance foreign to the concrete curing process, such as grease or oil, will be cause for rejection.

- 2.8. **Epoxy.** Provide epoxy materials that conform to DMS-6100, "Epoxies and Adhesives," unless otherwise specified.

3. EQUIPMENT

- 3.1. **Fogging Equipment.** Use fogging equipment that can apply water in a fine mist, not a spray. Produce the fog using equipment that pumps water or water and air under high pressure through a suitable atomizing nozzle. Use hand-held mechanical equipment portable enough to use in the direction of any prevailing wind and adaptable for intermittent use to prevent excessive wetting of the concrete.

- 3.2. **Transporting and Placing Equipment.** Use appropriate transporting and placing equipment such as buckets, chutes, buggies, belt conveyors, pumps, or other equipment as necessary. Do not transport or convey concrete through equipment made of aluminum. Use carts with pneumatic tires for carting or wheeling concrete over newly placed slabs.

Use tremies that are watertight to control the fall of concrete and of large enough diameter to allow the placement of the concrete but less than 14 in. in diameter.

Use pumps with lines at least 5 in. inside diameter (I.D.) where Grade 2 or smaller coarse aggregate is used and at least 8 in. I.D. for Grade 1 coarse aggregate.

- 3.3. **Vibrators.** Use immersion-type vibrators for consolidation of concrete. Provide at least 1 standby vibrator for emergency use. Furnish vibrator head covered by a rubberized or elastomeric cover when used near epoxy coated reinforcing steel.

- 3.4. **Screeds and Work Bridges for Bridge Slabs.** Use a self-propelled transverse screed or a mechanical longitudinal screed for bridge slabs. Use transverse screeds that are able to follow the skew of the bridge for skews greater than 15° unless otherwise approved. Equip transverse screeds with a pan float. Manually operated screeding equipment may be used if approved for top slabs of culverts, small placements, or unusual conditions. Use screeds that are rigid and heavy enough to hold true to shape and have sufficient adjustments to provide for the required camber or section. Equip the screeds, except those of the roller drum type, with metal cutting edges.

Use sufficient work bridges for finishing operations for bridge slabs. Mount a carpet drag to a work bridge or a moveable support system that can vary the area of carpet in contact with the concrete. Use carpet pieces long enough to cover the entire width of the placement. Splice or overlap the carpet as necessary. Ensure enough carpet is in contact longitudinally with the concrete being placed to provide the desired surface finish. Use artificial grass-type carpeting with a molded polyethylene pile face with a blade length between 5/8 and 1 in. and minimum weight of 70 oz. per square yard. Ensure the carpet has a strong, durable backing not subject to rot and the facing is adequately bonded to the backing to withstand the intended use. A burlap drag, attached to the pan float on a transverse screed, may be used instead of the carpet drag.

- 3.5. **Temperature Recording Equipment.** Use strip chart temperature recording devices, recording maturity meters in accordance with Tex-426-A, or other approved devices that are accurate within $\pm 2^\circ\text{F}$ within the range of 32°F to 212°F.

- 3.6. **Artificial Heating Equipment.** Use artificial heating equipment as necessary for maintaining the concrete temperatures as specified in Section 422.4.6.11., "Placing Concrete in Cold Weather."
- 3.7. **Sawing Equipment.** Use sawing equipment capable of cutting grooves in completed bridge slabs and top slabs of direct traffic culverts. Provide grooves that are 1/8 to 3/16 in. deep, nominally 1/8 in. wide, and spaced at 1 in. Use sawing equipment capable of cutting grooves in hardened concrete within 18 in. of the barrier rail or curb.
- 3.8. **Spraying Equipment.** Use mechanically powered pressure sprayers with appropriate atomizing nozzles for the application of membrane curing. Mechanically driven spraying equipment, adaptable to the rail system used by the screeds, may be used for applying membrane curing to bridge slabs. Use hand-pressurized spray equipment equipped with 2 or 3 fan-spray nozzles if approved. Ensure the spray from each nozzle overlaps the spray from adjacent nozzles by approximately 50%.
- 3.9. **Concrete Testing Equipment.** Provide testing equipment for the Engineer's use in accordance with Section 421.3.3., "Testing Equipment."

4. CONSTRUCTION

Obtain approval for proposed construction methods before starting work. Approval of construction methods and equipment does not relieve the Contractor's responsibility for safety or correctness of methods, adequacy of equipment, or completion of work in full accordance with the Contract. Attend the pre-construction (pre-pour) meetings for bridge slabs conducted by the Engineer. Provide and obtain approval for proposed finishing methods, interim curing methods, and final curing methods.

Unless otherwise shown on the plans, it is the Contractor's option to perform testing on structural concrete (structural classes of concrete are identified in Table 8 of Section 421.4.1., "Classification of Concrete Mix Designs,") to determine the in-situ strength to address the schedule restrictions listed below. The Engineer may require the Contractor to perform this testing for concrete placed in cold weather. Make enough test specimens for Contractor-performed testing to ensure strength requirements are met for the operations listed below. Make at least 1 set of test specimens for each element cast each day. Cure these specimens under the same conditions as the portion of the structure involved for all stages of construction. Ensure safe handling, curing, and storage of all test specimens. Provide testing personnel, and sample and test the hardened concrete in accordance with Section 421.4.8., "Sampling and Testing of Concrete." The maturity method, Tex-426-A, may be used for in-situ strength determination for schedule restrictions if approved. Coring will not be allowed for in-situ strength determination for schedule restrictions. Provide the Engineer the opportunity to witness all testing operations. Report all test results to the Engineer.

If the Contractor does not wish to perform schedule restriction testing, the Engineer's 7-day lab-cured tests, performed in accordance with Article 421.5., "Acceptance of Concrete," will be used for schedule restriction determinations. The Engineer may require additional time for strength gain to account for field curing conditions such as cold weather.

- 4.1. **Schedule Restrictions and Inspection Hold-Points.**
- 4.1.1. **Placement of Superstructure Members.** Place or cast superstructure members after the substructure concrete has attained a compressive strength of 3,000 psi.
- 4.1.2. **Longitudinal Screeding of Bridge Slabs.** Place a longitudinal screed directly on previously placed concrete slabs to check and grade an adjacent slab only after the previously placed slab has aged at least 24 hr. Place and screed the concrete after the previously placed slabs have aged at least 48 hr. Maintain curing of the previously placed slabs during placement.
- 4.1.3. **Staged Placement of Bridge Slabs on Continuous Steel Units.** Ensure the previously placed concrete attains a compressive strength of 3,000 psi when staged placement of a slab is required or used before

placing the next stage placement. Multiple stages may be placed in a single day if approved by the Engineer of Record.

- 4.1.4. **Storage of Materials on the Structure.** Obtain approval to store materials on completed portions of a structure once a compressive strength of 3,000 psi has been attained. Maintain proper curing if materials will be stored on structures before completion of curing.
- 4.1.5. **Placement of Equipment and Machinery.** Do not place erection equipment or machinery on the structure until the concrete has attained the design strength specified in Section 421.4.1., "Classification of Concrete Mix Designs," unless otherwise approved.
- 4.1.6. **Carting of Concrete** Cart, wheel, or pump concrete over completed slabs after the completed concrete has attained a compressive strength of 3,000 psi. Maintain curing during these operations.
- 4.1.7. **Placing Bridge Rails.** Reinforcing steel and concrete for bridge rails may be placed on bridge slabs once the slab concrete has attained a compressive strength of 3,000 psi. Ensure the slab concrete has attained its design strength specified in Section 421.4.1., "Classification of Concrete Mix Designs," before placing railing concrete if slipforming methods are used for railing concrete.
- 4.1.8. **Opening to Construction Traffic.** Bridges may be opened to all construction traffic when the design strength specified in Section 421.4.1., "Classification of Concrete Mix Designs," has been attained if curing is maintained. Avoid crossing bridges at high speeds until railing concrete, if present, has attained a compressive strength of 3,000 psi.
- 4.1.9. **Opening to Full Traffic.** Bridges may be opened to the traveling public when the design strength specified in Section 421.4.1., "Classification of Concrete Mix Designs," has been attained for all structural elements including railing subject to impact from traffic and when curing has been completed for all slabs. Obtain approval before opening bridges to the traveling public.
- 4.1.10. **Inspection Hold-Points.** Notify Engineer of progress of work and when work is complete before beginning next stage of work.
- Beam erection and bracing
 - Formwork, including setting of precast panels
 - Placing reinforcing steel
 - Screed dry run and pre-pour clear cover checks
 - Attend pre-pour meeting conducted by the Engineer
 - Post-curing crack inspection
- 4.2. **Forms.** Submit forming plans for decks or slabs on beams or girders, overhangs, cast-in-place spans, and bracing systems for girders when the overhang exceeds 3 ft. 6 in. Submit similar plans for other units of the superstructure as directed. Show all essential details of proposed forms and bracing. Have a licensed professional engineer design, seal, and sign these plans. Department approval is not required, but the Department reserves the right to request modifications to the plans. The Contractor is responsible for the adequacy of these plans.

Design job-fabricated formwork assuming a weight of 150 pcf for concrete, and include a minimum liveload allowance of 50 psf of horizontal surface of the form. Do not exceed 125% of the allowable stresses used by the Department for the design of structures.

Use conventional forms, permanent metal deck forms, or prestressed concrete panels for slabs on beams or girders unless indicated otherwise. Use permanent metal deck forms or conventional forms for thickened slabs, diaphragms, or other regions as shown on the plans where prestressed concrete panels are not used. Provide prestressed concrete panels as shown on the plans and in accordance with Item 424, "Precast Concrete Structural Members (Fabrication)." Provide copies of the precast panel layout drawings from the panel fabricator.

Use only material that is inert, non-biodegradable, and nonabsorptive for forms to be left in place.

Overhang form supports that transmit a horizontal force to a steel girder or beam or to a prestressed concrete beam are permitted provided a satisfactory structural analysis has been made of the effect on the girder or beam as indicated in the submitted formwork plans.

Use beam bracing as indicated on the plans when overhang brackets are used on prestressed concrete beam spans with slab overhangs not exceeding 3 ft. 6 in. Provide and design additional support or bracing for the outside beams regardless of the type of beam used for spans with overhangs exceeding this amount.

Attachment of forms or screed supports for bridge slabs to steel I-beams or girders may be by welding subject to the following requirements:

- Do not weld to tension flanges or to areas indicated on the plans.
- Weld in accordance with Item 448, "Structural Field Welding."

When setting forms of any type take into account:

- deflections due to cast-in-place slab concrete and railing shown in the dead load deflection diagram,
- differential beam or girder deflections due to skew angles and the use of certain stay-in-place slab forming systems, and
- deflection of the forming system due to the wet concrete.

Securely stake forms to line and grade and maintain in position for bridge approach slabs. Rigidly attach inside forms for curbs to the outside forms.

Construct all forms to permit their removal without marring or damaging the concrete. Clean all forms and footing areas of any extraneous matter before placing concrete. Provide openings in forms if needed for the removal of laitance or foreign matter.

Treat the facing of all forms with bond-breaking coating of composition that will not discolor or injuriously affect the concrete surface. Take care to prevent coating of the reinforcing steel.

Complete all preparatory work before placing concrete.

- 4.2.1. **Precast Panels.** Profile each beam to determine the actual camber or sag of the beams before placing panels. Adjust the profile grade line, panel elevation, and bearing seat elevations as needed to obtain the required cover over the slab reinforcement and slab thickness while maintaining ride quality. Make adjustments over suitable increments when a profile grade line adjustment is necessary, depending on span lengths, so the revised grade line will produce a uniform profile and good riding qualities. Obtain approval for the grade adjustments before placement. Consider actual beam camber in adjacent spans or slab placements when adjusting the grade line. Inspect each panel before being placed for cracks and other damage. Refer to Section 424.4.3.1., "Defects and Breakage," for rejection criteria due to cracking and other damage.
- 4.2.2. **Permanent Metal Decking.** Submit signed and sealed design calculations in addition to the required formwork drawings. Design and install formwork in accordance with the plans and formwork drawings. The plans will govern in cases where the plans and the formwork drawings conflict.
- 4.2.3. **Conventional Forms.** Provide properly seasoned good-quality lumber free from imperfections that would affect its strength or impair the finished surface of the concrete. Provide timber or lumber that meets or exceeds the requirements for species and grade in the submitted formwork plans.

Maintain forms or form lumber that will be reused so that it stays clean and in good condition. Do not use any lumber that is split, warped, bulged, or marred or that has any defect that will produce inferior work; remove such lumber from the work.

Use plywood at least 3/4 in. thick. Use plywood for forming surfaces that remain exposed that meets the requirements for B-B Plyform Class I or Class II Exterior of the U.S. Department of Commerce Voluntary Product Standard PS 1.

Space studs and joists so that the facing form material remains in true alignment under the imposed loads.

Place forms with the form panels symmetrically (long dimensions set in the same direction) for surfaces exposed to view and receiving only an ordinary surface finish as defined in Section 420.4.13., "Ordinary Surface Finish." Make horizontal joints continuous.

Make molding for chamfer strips or other uses of materials of a grade that will not split when nailed and can be maintained to a true line without warping. Dress wood molding on all faces. Fill forms at all sharp corners and edges with triangular chamfer strips measuring 3/4 in. on the sides unless otherwise shown on the plans.

- 4.3. **Placing Reinforcement.** Place reinforcement as provided in Item 440, "Reinforcement for Concrete." Do not weld reinforcing steel supports to I-beams or girders or to reinforcing steel except where shown on the plans.
- 4.4. **Drains.** Install and construct weep holes and roadway drains as shown on the plans.
- 4.5. **Extending Existing Slabs.** Verify pertinent dimensions and elevations of the existing structure before ordering any required materials.
- 4.5.1. **Removal.** Remove portions of the existing structure to the lines and dimensions shown on the plans or as directed. Dispose of these materials as shown on the plans or as directed. Remove any metal railing without damaging it, and stack it neatly on the right of way at locations that do not interfere with traffic or construction or at locations shown on the plans. All removed metal railing remains the property of the Department unless otherwise shown on the plans. Repair any portion of the remaining structure damaged as a result of the construction. Do not use explosives to remove portions of the existing structure unless approved in writing. Do not use a demolition ball, other swinging weight, or impact equipment unless shown on the plans. Use pneumatic or hydraulic tools for final removal of concrete at the "break" line. Use removal equipment, as approved that will not damage the remaining concrete.
- 4.5.2. **Reuse of Removed Portions of Structure.** Detach and remove all portions of the old structure that are to be incorporated into the extended structure to the lines and details as specified on the plans or as directed. Move the unit to be reused to the new location specified using approved methods. Place the reinforcement and extension concrete according to the plan details.
- 4.5.3. **Breaking Back Bridge Slabs.** Saw the top surface of the slab for bridge slabs and direct traffic slabs of box culverts along the "break" line to a depth of 1/2 in. before breaking back. Do not cut the reinforcement at the "break" line. Sever the concrete at the "break" line. Do not damage the remaining reinforcement within 1 lap length of the "break" line during removal of the designated portion of the existing structure.
- 4.5.4. **Splicing Reinforcing Steel.** Splice new reinforcing bars to exposed bars in the existing structure using lap splices in accordance with Item 440, "Reinforcement for Concrete," unless otherwise shown on the plans. The new reinforcing steel does not need to be tied to the existing steel where spacing or elevation does not match that of the existing steel provided the lap length is attained. Weld in accordance with Item 448, "Structural Field Welding," when welded splices are permitted. Install any required dowels in accordance with Section 422.4.6.10., "Installation of Dowels and Anchor Bolts."
- 4.5.5. **Concrete Preparation.** Roughen and clean concrete surfaces that are in contact with new construction before the placing of forms. Prepare these construction joint surfaces in accordance with Section 422.4.6.7., "Construction Joints."
- 4.6. **Placing Concrete.** Do not place concrete unless approval is obtained for the hold-point inspections as outlined in Section 422.4.1.10., "Inspection Hold-Points," and the pre-pour meeting has been conducted. Give the Engineer sufficient advance notice before placing concrete in any unit of the structure to permit the final inspection of forms, reinforcing steel placement, and other preparations. Obtain approval for proposed

curing methods based on forecast weather conditions for the expected duration of the pour and use the evaporation rate nomograph as mentioned below to determine the required curing options.

Follow the sequence of placing concrete shown on the plans or specified.

Do not place concrete when impending weather conditions would impair the quality of the finished work. Place concrete in early morning or at night or adjust the placement schedule for more favorable weather if conditions of wind, humidity, and temperature are such that concrete cannot be placed without the potential for plastic shrinkage cracking. Consult the evaporation rate nomograph in the Portland Cement Association's *Design and Control of Concrete Mixtures* or the evaporation rate spreadsheet available on the Department's website for shrinkage cracking potential. Adequately illuminate the entire placement site when mixing, placing, and finishing concrete in non-daylight hours as approved.

Furnish adequate shelter to protect the concrete against damage from rainfall or from freezing temperatures as outlined in this Item if changes in weather conditions require protective measures after work starts. Continue operations during rainfall only if approved. Use protective coverings for the material stockpiles. Cover aggregate stockpiles only to the extent necessary to control the moisture conditions in the aggregates.

Allow at least 1 curing day after the concrete has achieved initial set before placing strain on projecting reinforcement to prevent damage to the concrete.

4.6.1. **Placing Temperature.** Place superstructure concrete only when its temperature at the time of placement is between 50°F and 85°F. Increase the minimum placement temperature to 60°F if slag cement is used in the concrete.

4.6.2. **Transporting Time.** Begin the discharge of concrete delivered in truck mixers within the times listed in Table 14 of Item 421, "Hydraulic Cement Concrete."

4.6.3. **Workability of Concrete.** Place concrete with a slump as specified in Section 421.4.2.5., "Slump." Placing concrete with slump exceeding maximum specified may result in bridge deck cracking and be subject to Section 422.4.10., "Defective Work." Water may be added to the concrete before discharging any concrete from the truck to adjust for low slump provided the maximum mix design water-cement ratio is not exceeded. Mix concrete after introduction of any additional water or chemical admixtures in accordance with Section 421.4.6., "Mixing and Delivering Concrete." Do not add water or chemical admixtures after any concrete has been discharged.

4.6.4. **Transporting Concrete.** Use a method and equipment capable of maintaining the rate of placement shown on the plans or required by this Item to transport concrete to the forms. Transport concrete by buckets, chutes, buggies, belt conveyors, pumps, or other methods.

Protect concrete transported by conveyors from sun and wind to prevent loss of slump and workability. Shade or wrap with wet burlap pipes through which concrete is pumped as necessary to prevent loss of slump and workability.

Arrange and use chutes, troughs, conveyors, or pipes so the concrete ingredients will not be separated. Terminate such equipment in vertical downspouts, when necessary, to prevent segregation. Extend open troughs and chutes, if necessary, down inside the forms or through holes left in the forms.

Keep all transporting equipment clean and free from hardened concrete coatings. Discharge water used for cleaning clear of the concrete.

4.6.5. **Preparation of Surfaces.** Thoroughly wet all forms, prestressed concrete panels, T-beams, slab beams, and concrete box beams on which concrete is to be placed before placing concrete on them. Remove free water from the surface or beam lines before placing concrete. Provide surfaces that are in a moist, saturated surface-dry condition when concrete is placed on them.

Ensure the subgrade or foundation is moist before placing concrete for bridge approach slabs.

- 4.6.6. **Expansion Joints.** Construct joints and devices to provide for expansion and contraction in accordance with plan details and the requirements of this Section and Item 454, "Bridge Expansion Joints."

Prevent bridging of concrete or mortar around expansion joint material in bearings and expansion joints.

Use forms adaptable to loosening or early removal in construction of all open joints and joints to be filled with expansion joint material. Loosen these forms as soon as possible after final concrete set to permit free movement of the span without requiring full form removal and avoid expansion or contraction damage to the adjacent concrete.

Provide preformed fiber joint material or a high density foam in the vertical joints of the roadway slab, curb, median, or sidewalk when the plans show a Type A joint, and fill the top 1 in. with the specified joint sealing material unless noted otherwise. Install the sealer in accordance with Item 438, "Cleaning and Sealing Joints," and the manufacturer's recommendations.

Use light wire or nails to anchor any preformed fiber joint material to the concrete on 1 side of the joint.

Ensure that finished joints conform to the plan details with the concrete sections completely separated by the specified opening or joint material.

Remove all concrete within the joint opening soon after form removal and again where necessary after surface finishing to ensure full effectiveness of the expansion joint.

- 4.6.7. **Construction Joints.** A construction joint is formed by placing plastic concrete in direct contact with concrete that has attained its initial set. Monolithic placement means the manner and sequence of concrete placing does not create a construction joint.

Make construction joints of the type and at the locations shown on the plans. Do not make joints in bridge slabs not shown on the plans unless approved. Additional joints in other members are not permitted without approval. Place authorized additional joints using details equivalent to those shown on the plans for joints in similar locations.

Make construction joints square and normal to the forms unless otherwise required. Use bulkheads in the forms for all vertical joints.

Thoroughly clean the hardened concrete surface of all loose material, laitance, dirt, and foreign matter, and saturate it with water. Remove all free water and moisten the surface before concrete or bonding grout is placed against it. Ensure the surface of the existing concrete is in a saturated surface-dry (SSD) condition just before placing subsequent concrete. Prewet the existing concrete by ponding water on the surface for 24 hr. before placing subsequent concrete. Use high-pressure water blasting to achieve SSD conditions 15 to 30 min. before placing the concrete if ponding is not possible. An SSD condition is achieved when the surface remains damp when exposed to sunlight for 15 min.

Draw forms tight against the existing concrete to avoid mortar loss and offsets at joints.

Bonding agents are not required unless indicated otherwise. Coat the joint surface with bonding mortar, grout, epoxy, or other material as indicated on the plans or other Items if a bonding agent is required. Provide Type V epoxy per DMS-6100, "Epoxy and Adhesives," for bonding fresh concrete to hardened concrete. Place the bonding epoxy on a clean, dry surface, and place the fresh concrete while the epoxy is still tacky. Place bonding mortar or grout on a surface that is SSD, and place the concrete before the bonding mortar or grout dries. Place other bonding agents in accordance with the manufacturer's recommendations.

- 4.6.8. **Handling and Placing.** Minimize segregation of the concrete and displacement of the reinforcement when handling and placing concrete. Produce a uniform, dense, compact mass.

Do not allow concrete to free-fall more than 5 ft. Remove any hardened concrete splatter ahead of the plastic concrete.

Fill each part of the forms by depositing concrete as near its final position as possible. Do not deposit large quantities at one point and run or work the concrete along the forms.

Avoid cold joints in a monolithic placement. Sequence successive layers or adjacent portions of concrete so they can be vibrated into a homogeneous mass with the previously placed concrete before it sets.

- 4.6.9. **Consolidation.** Carefully consolidate concrete and flush mortar to the form surfaces with immersion type vibrators. Do not use vibrators that operate by attachment to forms or reinforcement except where approved on steel forms.

Vibrate the concrete immediately after deposit. Systematically space points of vibration to ensure complete consolidation and thorough working of the concrete around the reinforcement, embedded fixtures, and into the corners and angles of the forms. Insert the vibrator vertically where possible except for slabs where it may be inserted in a sloping or horizontal position. Vibrate the entire depth of each lift, allowing the vibrator to penetrate several inches into the preceding lift. Do not use the vibrator to move the concrete to other locations in the forms. Do not drag the vibrator through the concrete. Thoroughly consolidate concrete along construction joints by operating the vibrator along and close to but not against the joint surface. Continue the vibration until the concrete surrounding reinforcements and fixtures is completely consolidated. Hand-spade or rod the concrete if necessary to ensure flushing of mortar to the surface of all forms. Concentrate vibration efforts along the beams lines when precast concrete panels are used for deck construction.

- 4.6.10. **Installation of Dowels and Anchor Bolts.** Install dowels and anchor bolts by casting them in-place or by grouting with grout, epoxy, or epoxy mortar unless noted otherwise. Form or drill holes for grouting. Use only epoxy when installing horizontal dowels into the edges of slabs. Follow the manufacturer's recommended installation procedures for pre-packaged grout or epoxy anchor systems. Test anchors if required on the plans or by other items.

Drill holes for anchor bolts to accommodate the bolt embedment required by the plans. Make holes for dowels at least 12 in. deep unless otherwise shown on the plans. Make the hole diameter at least twice the dowel or bolt diameter, but the hole need not exceed the dowel or bolt diameter plus 1-1/2 in. when using cementitious grout or epoxy mortar. Make the hole diameter 1/16 to 1/4 in. greater than the dowel or bolt diameter when using neat epoxy unless indicated otherwise by the epoxy manufacturer.

Thoroughly clean holes of all loose material, oil, grease, or other bond-breaking substance, and blow them clean with filtered compressed air. Use a wire brush followed by oil-free compressed air to remove all loose material from the holes, repeating as necessary until no more material is removed. Ensure holes are in a surface-dry condition when epoxy type materials are used and in a surface-moist condition when cementitious grout is used. Develop and demonstrate for approval a procedure for cleaning and preparing the holes for installation of the dowels and anchor bolts. Completely fill the void between the hole and dowel or bolt with grouting material. Follow exactly the requirements for cleaning outlined in the product specifications for pre-packaged systems.

Provide a Type III epoxy per DMS-6100, "Epoxyes and Adhesives," when neat epoxy is used for anchor bolts or dowels. Provide Type VIII epoxy per DMS-6100, "Epoxyes and Adhesives," when an epoxy grout is used. Provide grout, epoxy, or epoxy mortar as the binding agent unless otherwise indicated on the plans.

Provide other anchor systems as required on the plans.

- 4.6.11. **Placing Concrete in Cold Weather.** Protect concrete placed under weather conditions where weather may adversely affect results. Permission given by the Engineer for placing during cold weather does not relieve the Contractor of responsibility for producing concrete equal in quality to that placed under normal conditions. If concrete placed under poor conditions is unsatisfactory, remove and replace it as directed at Contractor's expense.

Do not place concrete in contact with any material coated with frost or with a temperature of 32°F or lower. Do not place concrete when the ambient temperature in the shade is below 40°F and falling unless approved. Place concrete when the ambient temperature in the shade is at least 35°F and rising or above 40°F.

Provide and install recording thermometers, maturity meters, or other suitable temperature measuring devices to verify all concrete is effectively protected. Maintain the temperature of the top surface of bridge slabs and top slabs of direct traffic culverts at 50°F or above for 72 hr. from the time of placement and above 40°F for an additional 72 hr.

Use additional covering, insulated forms, or other means and, if necessary, supplement the covering with artificial heating. Avoid applying heat directly to concrete surfaces. Cure as specified in Section 422.4.8., "Final Curing," during this period until all requirements for curing have been satisfied.

Have on hand all necessary heating and covering material, ready for use, before permission is granted to begin placement when impending weather conditions indicate the possible need for temperature protection. Distress caused by concrete drying out as a result of delayed set and strength gain associated with cold weather are a result of the Contractor's actions and are subject to repair in accordance with Section 422.4.10., "Defective Work."

- 4.6.12. **Placing Concrete in Hot Weather.** Use an approved Type B or D set retarding agent in all concrete for superstructures and top slabs of direct traffic culverts, except concrete containing slag cement, when the temperature of the air is above 85°F unless otherwise directed.

Keep the concrete at or below the maximum temperature at time of placement as specified above. Sprinkle and shade aggregate stockpiles or use ice, liquid nitrogen systems, or other approved methods as necessary to control the concrete temperature.

- 4.6.13. **Placing Concrete in Superstructure.** Place simple span bridge slabs without transverse construction joints by using either a self-propelled transverse finishing machine or a mechanical longitudinal screed unless otherwise shown on the plans. Use of manually operated screeding equipment may be permitted for small placements or for unusual conditions such as narrow widening, variable cross slopes, or transitions. Support the screed adequately on a header or rail system stable enough to withstand the longitudinal or lateral thrust of the equipment. Adjust the profile grade line as necessary to account for variations in beam camber and other factors to obtain the required slab thickness and concrete cover over the slab reinforcement. Set beams and verify their surface elevations in a sufficient number of spans so that when adjustment is necessary, the profile grade line can be adjusted over suitable increments to produce a smooth riding surface. Take dead load deflection into account in setting the grades of headers and rail systems. Use construction joints, when required or permitted for slab placements on steel or prestressed concrete beams, as shown on the plans. Release falsework under the spans before placing concrete on steel girder or truss spans, and swing the spans free on their permanent supports.

Provide additional camber to offset the initial and final deflections of the span as indicated on the plans for concrete flat slab, concrete slab, and girder spans cast-in-place on falsework. Provide camber of approximately 3/8 in. for 30-ft. spans and 1/2 in. for 40-ft. spans to offset initial and final deflections for concrete slab and girder spans using pan forms unless otherwise directed. Provide a camber of 1/8 in. for 10-ft. spans but no more than 1/2 in. for concrete flat slab, concrete slab, and girder spans not using pan forms when dead load deflection is not shown on the plans.

Provide a camber of 1/4 in. in addition to deflection for slabs without vertical curvature on steel or prestressed concrete beams. Provide camber for specified vertical curvature and transverse slopes.

Make 1 or more passes with the screed over the bridge slab segment before placing concrete on it to ensure proper operation and maintenance of grades and clearances. Use an approved system of checking to detect any vertical movement of the forms or falsework. Maintain forms for the bottom surface of concrete slabs, girders, and overhangs to the required vertical alignment during concrete placing.

Level, strike off, and screed the surface while carrying a slight excess of concrete ahead of the screed to fill all low spots as soon as the concrete has been placed and vibrated in a section wide enough to permit working. Move longitudinal screeds across the concrete with a saw-like motion while their ends rest on headers or templates set true to the roadway grade or on the adjacent finished slab. Move transverse screeds longitudinally approximately 1/5 of the drum length for each complete out-and-back pass of the carriage. Screed the surface of the concrete enough times and at intervals to produce a uniform surface true to grade and free of voids.

Fog unformed surfaces of slab concrete in bridge slabs and in top slabs of direct traffic culverts from the time of initial strikeoff of the concrete until finishing is completed and required interim curing is in place. Do not use fogging as a means to add finishing water and do not work moisture from the fog spray into the fresh concrete.

Retard the concrete for simple spans only if necessary to complete finishing operations or as required by this Section. Bring the top of curb and sidewalk section to the correct camber and alignment when filling curb forms, and finish them as described in this Item.

- 4.6.13.1. **Transverse Screeding.** Install rails for transverse finishing machines that are supported from the beams or girders so the supports may be removed without damage to the slab. Prevent bonding between removable supports and the concrete in an acceptable manner. Do not allow rail support parts that remain embedded in the slab to project above the upper mat of reinforcing steel. Rail or screed supports attached to I-beams or girders are subject to the requirements of this Item. Place concrete at a minimum rate of 30 ft. of bridge slab per hour for transverse screeding unless otherwise shown on the plans. Deposit concrete parallel to the skew of the bridge so all girders are loaded uniformly along their length. Deposit slab concrete between the exterior beam and adjacent beam before placing concrete in the overhang portion of the slab. Furnish personnel and equipment capable of placing, finishing, and curing the slab at an acceptable rate to ensure compliance with the specifications. Place concrete in transverse strips. Start placement at the lowest end on profile grades greater than 1-1/2%.

At the Contractor's option, attach a pan drag and either a carpet or burlap drag to the screed assembly to float and provide surface micro-texture in one operation. Adjust the contact pressure of the pan drag to smooth high spots and fill any depressions left by the screed. Adjust the weight or position of the carpet or burlap drag to produce a smooth sandy micro-texture without blemishes, marks, or scratches deeper than 1/16 in. Fill screed rail support holes and holes from the Engineer's depth checks for slab thickness and reinforcing cover with concrete, and finish them to match the rest of the slab.

- 4.6.13.2. **Longitudinal Screeding.** Use of temporary intermediate headers will be permitted for placements over 50 ft. long if the rate of placement is rapid enough to prevent a cold joint and if these headers are designed for easy removal to permit satisfactory consolidation and finish of the concrete at their locations unless otherwise shown on the plans. Deposit slab concrete between the exterior beam and the adjacent beam before placing concrete in the overhang portion of the slab. Place concrete in longitudinal strips starting at a point in the center of the segment adjacent to 1 side except as this Section indicates, and complete the strip by placing uniformly in both directions toward the ends. Start placing at the lowest end for spans on a profile grade of 1-1/2% or more. Use strips wide enough that the concrete within each strip remains plastic until placement of the adjacent strip. Place the concrete in proper sequence to be monolithic with the adjacent longitudinal strips of the slabs where monolithic curb construction is specified.

- 4.6.13.3. **Placements on Continuous Steel Units.** Place slabs on continuous steel units in a single, continuous operation without transverse construction joints using a self-propelled transverse finishing machine or a mechanical longitudinal screed unless otherwise shown on the plans. Retard the initial set of the concrete sufficiently to ensure concrete remains plastic in at least 3 spans immediately preceding the slab being placed. Use construction joints, when required for slab placements on steel beams or girders, as shown on the plans. Ensure the previously placed concrete attains a compressive strength of 3,000 psi when staged placement of a slab is required on the plans before placing the next stage concrete. Multiple stages may be placed in a single day if approved. Use an approved placing sequence that will not overstress any of the supporting members where plans permit staged placing without specifying a particular order of placement.

- 4.6.13.4. **Slab and Girder Units.** Place girders, slab, curbs of slab, and girder spans monolithically unless otherwise shown on the plans. Fill concrete girder stems first, and place the slab concrete within the time limits specified in this Item. Place concrete in the stems for a short distance if using a transverse screed, and then place the concrete in transverse strips. Fill the outside girder stem first, beginning at the low end or side, if using a longitudinal screed, and continue placement in longitudinal strips.
- 4.7. **Finish and Interim Curing of Bridge Slabs.** Obtain approval of the proposed interim curing methods, equipment, and materials at the pre-pour meeting before placing concrete. Take into account forecast weather conditions to determine the interim curing methods to use.
- Use work bridges or other suitable facilities to perform all finishing operations and to provide access, if necessary, for the Engineer to check measurements for slab thickness and reinforcement cover.
- Work the screeded surface to a smooth finish with a long-handled wood or metal float or hand-float it from work bridges over the slab. Floating may not be necessary if the pan float attached to a transverse screed produces an acceptable finish. Avoid overworking the surface of the concrete. Avoid use of finish water.
- Perform sufficient checks, witnessed by the Engineer, with a long-handled 10-ft. straightedge on the plastic concrete to ensure the final surface will be within specified tolerances. Make the check with the straightedge parallel to the centerline. Lap each pass half over the preceding pass. Remove all high spots, and fill and float all depressions over 1/16 in. deep with fresh concrete. Continue checking and floating until the surface is true to grade and free of depressions, high spots, voids, or rough spots. Fill screed-rail support holes with concrete, and finish them to match the top of the slab.
- Provide a uniform micro-texture using a carpet drag, burlap drag, or broom finish. Finish the surface to a smooth sandy texture without blemishes, marks, or scratches deeper than 1/16 in. Apply the surface texturing using a work bridge or platform immediately after completing the straightedge checks. Draw the carpet or burlap drag longitudinally along the concrete surface, adjusting the surface contact area or pressure to provide a satisfactory coarsely textured surface. A broom finish may be performed using a fine bristle broom transversely. For bridge approach slabs the carpet drag, burlap drag, or broom finish may be applied either longitudinally or transversely.
- Evaporation protection is required if the evaporation rate exceeds 0.10 lbs./sf./hr. based on the *Evaporation Calculation for Concrete Worksheet* as shown on the Department's website, the evaporation rate nomograph in the Portland Cement Association's *Design and Control of Concrete Mixtures* or if indicated on the plans.
- 4.7.1. **Evaporation Protection.** Use one of the following methods for evaporation protection.
- 4.7.1.1. **Evaporation Retardant.** Coat the concrete surface immediately after the carpet or burlap drag, or broom finish with a single application of evaporation retardant at a rate recommended by the manufacturer. Do not allow more than 10 min. to elapse between the texturing at any location and application of evaporation retardant. The evaporation retardant may be applied using the same work bridge used for surface texturing. Do not work the concrete surface once the evaporation retardant has been applied.
- 4.7.1.2. **Wet Burlap.** Place pre-wet burlap no more than 10 ft. behind the finishing operation. A work bridge may be required to avoid marring the surface. Ensure the wet burlap covers the entire surface. Use sprayers, hoses, sprinklers, or other similar methods to keep the burlap continuously wetted until application of the final curing.
- 4.7.2. **Interim Curing.** Apply interim curing using one of the following options after applying the evaporation protection (if needed):
- 4.7.2.1. **Membrane Cure.** Apply membrane interim curing at a rate of approximately 180 sq. ft. per gallon. Apply before the water sheen disappears but do not place over standing water. Fog as necessary to maintain the wet sheen. Do not spray membrane curing on a dry surface.
- 4.7.2.2. **Wet Burlap.** Place pre-wet burlap no more than 10 ft. behind the finishing operation. Burlap used for evaporation protection will also be considered as the interim curing.

- 4.8. **Final Curing.** Obtain approval of the proposed curing methods, equipment, and materials at the pre-pour meeting before placing concrete. Inadequate curing or facilities may delay all concrete placements on the job until remedial action is taken. Apply final curing as soon as possible after interim curing without damaging the surface finish. Check the adequacy of the curing each day of the curing period. Take corrective action or modify the curing methods as needed to maintain a moist concrete surface.

A curing day is a calendar day when the temperature, taken in the shade away from artificial heat, is above 50°F for at least 19 hr. or, on colder days if the temperature of all surfaces of the concrete is maintained above 40°F, for the entire 24 hr. The required curing period begins when all concrete has attained its initial set. Tex-440-A may be used to determine when the concrete has attained its initial set.

Cure all superstructure concrete according to the following, unless otherwise shown on the plans:

- Concrete using Type I or III cement: 8 days
- Concrete using Type I/II or II cement: 10 days
- Concrete with any type of SCM: 10 days

Place polyethylene sheeting, burlap-polyethylene blankets, laminated mats, or insulating curing mats in direct contact with the slab when the air temperature is expected to drop below 40°F during the first 72 hr. of the curing period. Weigh down these curing materials with dry mats to maintain direct contact with the concrete and provide insulation against cold weather. Supplemental heating or insulation may be required in cold and wet weather if the insulating cotton mats become wet or the concrete drops below the specified curing temperature. Avoid applying heat directly to concrete surfaces.

Use one of the following water curing methods for final curing. Keep all exposed surfaces of the concrete wet continuously for the required curing time. Use water for curing that meets the requirements for concrete mixing water in Section 421.2.5., "Water." Do not use seawater or water that stains or leaves an unsightly residue.

- 4.8.1. **Cotton Mats.** Keep the concrete continuously wet by maintaining wet cotton mats in direct contact with the concrete for the required curing time. Weight the mats adequately to provide continuous contact with all concrete. Cover surfaces that cannot be cured by direct contact with mats, forming an enclosure well anchored to the forms or ground so outside air cannot enter the enclosure. Provide sufficient moisture inside the enclosure to keep all surfaces of the concrete wet. Use of soaker hoses and plastic covering is acceptable provided the concrete surface remains continuously wet for the required curing duration.
- 4.8.2. **Burlap Mats.** The burlap used for interim curing may also be used for final curing if kept continuously wetted and completely covered with plastic sheeting. Overlap plastic sheeting and weigh down sufficiently so air cannot get under the plastic.
- 4.8.3. **Burlap-Polyethylene Mats.** Place these mats over soaker hoses or other similar methods to keep the concrete surface wetted for the duration of the curing period. Overlap the mats and weight down sufficiently so air cannot get under the mats.
- 4.9. **Removal of Forms and Falsework.** Forms for vertical surfaces may be removed after the concrete has aged 12 hr. after initial set provided the removal can be done without damage to the concrete unless otherwise directed.

Remove forms for inside curb faces and for bridge rails whenever removal can be done without damage to the curb or railing.

Leave in place weight-supporting forms and falsework spanning more than 1 ft. except as directed otherwise until the concrete has attained a compressive strength of 2,500 psi. Remove forms for other structural components as necessary.

Forms or parts of forms may be removed only if constructed to permit removal without disturbing forms or falsework required to be left in place for a longer period on other portions of the structure.

Remove all metal appliances used inside forms for alignment to a depth of at least 1/2 in. from the concrete surface. Make the appliances so that metal may be removed without undue chipping or spalling of the concrete, and so that it leaves a smooth opening in the concrete surface when removed. Do not burn off rods, bolts, or ties.

Remove all forms and falsework unless otherwise directed.

Apply an ordinary surface finish as the final finish to the bottom of bridge slabs between girders or beams, and vertical and bottom surfaces of interior concrete beams or girders unless otherwise noted.

Form marks and chamfer edges do not need to be smoothed for the bottom of bridge slabs between girders or beams. Remove all fins, runs, drips, or mortar from surfaces that will be exposed.

- 4.10. **Defective Work.** The Contractor is responsible for the ride quality of the finished bridge slab. The Engineer will use a 10 ft. straightedge (1/8 in. in 10 ft.) to verify ride quality and determine locations where corrections are needed. Submit a plan for approval to produce a ride of acceptable quality if the Engineer determines the ride quality is unacceptable. Make all corrections for ride before saw-cutting grooves.

Repair defective work as soon as possible. Remove and replace at the expense of the Contractor any defect that cannot be repaired to the satisfaction of the Engineer.

The Engineer will inspect the deck or slab for plastic shrinkage and settlement cracking after completion of final curing and within 5 days after curing mats are removed. Seal any noted shrinkage cracks attributable to Contractor placing, curing, and finishing practices using gravity feed crack repair as directed in accordance with Item 780, "Concrete Crack Repair," at no cost to the Department. Transverse cracks over interior bents in continuous slab units do not need to be sealed in this manner.

- 4.11. **Final Surface Texture.** Saw-cut grooves in the hardened concrete of bridge slabs, bridge approach slabs, and direct traffic culverts to produce the final texturing after completion of the required curing period unless otherwise noted. Cut grooves perpendicular to the structure centerline. Cut grooves across the slab within 18 in. of the barrier rail, curb, or median divider. Adjust groove cutting at skewed metal expansion joints in bridge slabs by using narrow-width cutting heads so all grooves end within 6 in. of the joint, measured perpendicular to the centerline of the metal joint. Leave no ungrooved surface wider than 6 in. adjacent to either side of the joint. Ensure the minimum distance to the first groove, measured perpendicular to the edge of the concrete joint or from the junction between the concrete and the metal leg of the joint, is 1 in. Cut grooves continuously across construction joints or other joints in the concrete less than 1/2 in. wide. Apply the same procedure described above where barrier rails, curbs, or median dividers are not parallel to the structure centerline to maintain the 18 in. maximum dimension from the end of the grooves to the gutter line. Cut grooves continuously across formed concrete joints. Provide either a carpet drag or broom finish for micro-texture when saw-cut grooves are not required on the plans. In this case ensure an adequate and consistent micro-texture is achieved by applying enough weight to the carpet and keeping the carpet or broom from getting plugged with grout. For surfaces that do not have adequate texture, the Engineer may require corrective action including diamond grinding or shot blasting.

Give a carpet drag, burlap drag, or broom finish to all concrete surfaces to be overlaid when the plans call for a concrete overlay (CO) to be placed on the slab (new construction). Saw-grooving is not required in this case. Provide an average texture depth for the finish of approximately 0.035 in. with no individual test falling below 0.020 in., unless otherwise shown on the plans, when tested in accordance with Tex-436-A. Revise finishing procedures to produce the desired texture if the texture depth falls below what is intended.

Give all concrete surfaces to be covered a lightly textured broom or carpet drag finish when the plans require an asphalt seal, with or without overlay, on the slab (new construction). Provide an average texture depth of approximately 0.025 in. when tested in accordance with Tex-436-A.

5. MEASUREMENT

Reinforced concrete slabs or decks on girders, beams, slab beams, double-T beams, or box beams placed under this Item will be measured by the square foot of slab surface area using the nominal dimensions and configuration shown on the plans. Transverse measurement will be made from outer edge of slab to outer edge of slab (including raised median and sidewalk sections). Longitudinal measurement will be made between ends of units or spans. Diaphragms, haunch concrete, reinforcement, and optional steel diaphragms will be considered as a portion of the slab unless otherwise shown. An estimated quantity for the haunch between the slab and beams will be included for the Contractor's information only. No measurement will be made during construction for variation in the amount of haunch concrete due to variations in camber of the beams.

Approach slabs and cast-in-place superstructure elements including flat slabs, slab and girder units (pan formed), and shear keys will be measured by the cubic yard. For slab and girder spans using pan forms, a quantity will be included for the screed setting required to provide proper camber in the roadway surface after form removal.

This is a plans quantity measurement Item. The quantity to be paid is the quantity shown in the proposal unless modified by Article 9.2., "Plans Quantity Measurement." Additional measurements or calculations will be made if adjustment of quantities is required.

The quantities of concrete and reinforcing steel shown on the plans are based on a conventionally formed slab. These quantities include amounts for concrete diaphragms, brackets and other required attachments, and haunch concrete when required, based on the profile grade, theoretical camber, and dead load deflection of the beams. No additional measurement will be made for concrete or reinforcing steel due to a variation in camber of the beams from theoretical camber, or for additional quantities required by optional methods of forming.

Additional concrete that may be required by an adjustment of the profile grade line during construction, to ensure proper slab thickness, will not be measured for payment.

6. PAYMENT

The work performed and materials furnished in accordance with this Item and measured as provided under "Measurement" will be paid for at the unit price bid for the various superstructure elements specified. This price is full compensation for furnishing, hauling, mixing, placing, curing, and finishing concrete; furnishing and placing reinforcing steel; grouting and pointing; furnishing and placing drains and expansion joint material (except where specifically furnished under another Item); furnishing and placing metal flashing strips; forms (removable and permanent) and falsework; prestressed concrete panels; furnishing and placing concrete and reinforcement for raised medians, sidewalks, sign mounts, luminaire brackets, and other concrete appurtenances; removing designated portions of existing slab; cleaning, bending, and cutting exposed existing reinforcing steel; welding reinforcing steel; doweling; cleaning and preparing concrete surfaces; and equipment, labor, tools, and incidentals.

Price will be adjusted in accordance with Section 421.6., "Measurement and Payment," when required to address non-compliance of project acceptance testing.

Diaphragm concrete will not be paid for directly but is subsidiary to the slab unless otherwise shown on the plans.

Structural steel, anchor bolts, armor joints, sealed expansion joints, rail (including the concrete parapet portion), and concrete median barrier will be measured and paid for in accordance with pertinent bid items.

In addition to the work described above, for extending structures the unit prices bid is full compensation for removing and disposing of the designated portion of the existing structure; removing, stockpiling and replacing headwall units for reuse; cleaning, bending, and cutting of exposed reinforcing steel; splicing or

welding of new reinforcing steel to existing reinforcing steel; installation of dowels; and cleaning and preparing existing concrete surfaces.

Item 423

Retaining Walls



1. DESCRIPTION

Furnish, construct, and install retaining walls.

2. MATERIALS

2.1. **General.** Furnish materials in accordance with the following:

- Item 420, "Concrete Substructures,"
- Item 421, "Hydraulic Cement Concrete,"
- Item 440, "Reinforcement for Concrete,"
- Item 445, "Galvanizing,"
- Item 458, "Waterproofing Membranes for Structures," and
- Item 556, "Pipe Underdrains."

Use concrete for retaining walls that conforms to the requirements of Table 1 unless otherwise shown on the plans.

Table 1
Concrete for Retaining Walls

Application	Concrete
Cast-in-place, non-reinforced	Class A
Cast-in-place, reinforced	Class C
Precast	Class H, $f_c = 4,000$ psi

Furnish concrete for machine-made concrete block units in accordance with ASTM C90, Class 1, Type II, except the minimum 28-day compressive strength must be 4,000 psi with maximum moisture absorption of 7%.

Provide Type 1 filter fabric in accordance with DMS-6200, "Filter Fabric." Provide filter fabric rated as UV-resistant when used as part of the exposed facing for a temporary wall.

Joint fillers, pads, waterstops, and other incidental materials must be as shown on the plans or approved by the Engineer.

Epoxy coat all steel used in concrete panels and coping including connectors, dowels, stirrups, and reinforcing steel when the plans call for epoxy coating of steel earth reinforcements.

2.2. **Definitions.** This Item uses the following terms:

- **Permanent Wall.** A retaining wall with a design service life of 75 years. All walls are presumed to be permanent walls unless otherwise specified on the plans.
- **Temporary Wall.** A retaining wall so designated by description, with a design service life of 3 years.
- **Mechanically Stabilized Earth (MSE) Wall.** A wall consisting of a volume of select backfill with tensile earth reinforcement elements distributed throughout. Permanent MSE walls use a precast concrete panel as a facing element. Temporary MSE walls use welded wire fabric with filter fabric backing as a facing element.
- **Concrete Block Wall.** A retaining wall that uses machine-made, precast concrete block units as facing elements. The walls may use a volume of select fill with tensile earth reinforcements distributed throughout, or may use only the facing unit and unit fill weight for support.

2.3. **Fabrication.**2.3.1. **Cast-in-Place.** Meet Item 420, "Concrete Substructures."2.3.2. **Formed Precast.** Meet Item 424, "Precast Concrete Structural Members (Fabrication)."2.3.3. **Machine-Made Precast.** Furnish machine-made concrete block units in accordance with ASTM C90, sampled and tested in accordance with ASTM C140. Furnish units with molded dimensions within 1/8 in. of specified dimensions, except height must be within 1/16 in.2.4. **Backfill.**2.4.1. **Non-Select.** Furnish non-select backfill for walls other than temporary and permanent MSE and concrete block walls as indicated on the plans. Non-select fill will meet Item 132, "Embankment," of the type specified on the plans. Provide material with a maximum plasticity index of 30 if no type is specified as determined by Tex-106-E.2.4.2. **Select.** Select backfill is required in specific areas of permanent and temporary MSE and concrete block-type retaining walls. Provide select backfill that is free from organic or otherwise deleterious materials and that conforms to the gradation limits shown in Table 2 as determined by Tex-401-A.

Provide backfill that does not contain shale, caliche, or other soft, poor-durability coarse aggregate particles. Reclaimed Asphalt Pavement (RAP) is not allowed. Crushed Concrete or manufactured sand is allowed for temporary walls with a service life of 3 years or less. Test each source of backfill for durability/soundness using Tex-411-A, 5-cycle magnesium sulfate soundness. Backfill material with a maximum 5-cycle soundness loss exceeding 25% will be rejected. Alternately, Tex-461-A, Micro-Deval abrasion may be used if the corresponding results show loss is not greater than 20%, otherwise Tex-411-A governs aggregate verification.

Type AS, BS, and DS particles larger than 1/4 in. must be angular or completely crushed. Provide mechanically crushed gravel or stone backfill. Gravel from each aggregate source will have a minimum of 95% two or more mechanically induced crushed faces, as Tex-460-A, Part I determines. Rounded rock or rounded gravel is not allowed. Natural sand meeting the requirements of this Section is permitted for use.

Table 2
Select Backfill Gradation Limits

Type	Sieve Size	Percent Retained
AS	3"	0
	1/2"	50-100
	#4	See Note
	#40	85-100
	#200	95-100
BS	3"	0
	#4	See Note
	#40	40-100
	#200	85-100
CS	3"	0
	#4	See Note
	#200	75-100
DS	3"	0
	3/8"	85-100
	#200	95-100

Note—Use No. 4 sieve for determination of rock backfill as described in this main paragraph, "Backfill."

When the backfill gradation results in 85% or more material retained on the No. 4 sieve, the backfill will be considered rock backfill. All Type DS backfill is considered rock backfill.

In addition to the requirements for Type CS select fill, the fraction finer than the No. 200 sieve must have a Plasticity Index (PI) in accordance with Tex-106-E not greater than 6.

Furnish Type BS backfill for permanent walls; Type CS backfill for temporary walls; and Type DS backfill for areas of walls subject to inundation unless otherwise shown on the plans, or below the 100-year flood elevation as noted on the plans.

Furnish backfill meeting the requirements of this Section but with a maximum particle size of 3/4 in. when nonmetallic or epoxy coated earth reinforcements are used.

- 2.4.3. **Drainage Aggregate.** Use drainage aggregate to fill the void within concrete block units and in the zone 1 ft. behind the units. Provide drainage aggregate that is free from organic or otherwise deleterious materials and that conforms to the gradation limits in Table 3 as Tex-110-E determines.

Table 3
Drainage Aggregate Gradation Limits

Sieve Size	Percent Retained
1"	0
3/4"	25–50
1/2"	50–100
#4	75–100

- 2.4.4. **Cement-Stabilized Backfill.** Use cement-stabilized backfill when required or as approved. Stabilize Type CS backfill with 5% hydraulic cement by dry weight of the backfill material. Use a stationary plant to thoroughly mix the backfill material, cement, and water. Place and compact the backfill within 2 hours of mixing. Provide special drainage provisions when cement-stabilized backfill is used, as shown on the plans.
- 2.4.5. **Electrochemical.** Provide backfill meeting the following additional requirements for permanent retaining wall systems using galvanized metallic earth reinforcements:
- The pH is between 5.5 and 10.0 as Tex-128-E determines.
 - Resistivity is more than 3,000 ohm-cm as Tex-129-E determines.
 - Material with resistivity between 1,500 and 3,000 ohm-cm may be used if the chloride content is less than 100 ppm and the sulfate content is less than 200 ppm as Tex-620-J determines.

Perform electrochemical testing on the raw, unstabilized backfill material when cement-stabilized backfill is used.

- 2.5. **Earth Reinforcements.** Furnish earth reinforcements that meet the design requirements. Galvanize or epoxy coat all steel elements for permanent walls in contact with soil. Epoxy coat in accordance with Item 440, "Reinforcement for Concrete," except provide a minimum 18-mil coating thickness. Epoxy coat the reinforcing only when shown on the plans or as approved. Use connection hardware that is likewise nonmetallic or epoxy coated when using nonmetallic or epoxy coated earth reinforcements.

3. CONSTRUCTION

- 3.1. **General.** Construct retaining walls in accordance with details shown on the plans, on the approved working drawings, and to the pertinent requirements of the following Items:
- Item 110, "Excavation"
 - Item 132, "Embankment"
 - Item 400, "Excavation and Backfill for Structures"
 - Item 420, "Concrete Substructures"
 - Item 458, "Waterproofing Membranes for Structures"
 - Item 556, "Pipe Underdrains"

Construct required piling or drilled shafts in accordance with the pertinent specification.

- 3.2. **Options.** When optional design details are shown on the plans, the Contractor is required to use the same facing design within an area of continuous retaining walls.
- Provide drawings for review indicating the proposed design arrangement when proposing the use of 2 or more systems.
- 3.3. **Working Drawings.** When proprietary wall systems are used for permanent or temporary walls, submit casting drawings, construction drawings, and design calculations bearing the seal of a licensed professional engineer for review and approval following the Department's *Guide to Electronic Shop Drawing Submittal* process. Upon completion of construction, submit a set of reproducible as-built drawings.
- 3.3.1. **Casting Drawings.** Include all information necessary for casting wall elements, including railing and coping when prefabricated. Show shape and dimensions of panels; size, quantity, and details of the reinforcing steel; quantity, type, size, and details of connection and lifting hardware; and additional necessary details.
- 3.3.2. **Construction Drawings.** Include a numbered panel layout showing horizontal and vertical alignment of the walls as well as the existing and proposed groundlines. Include all information needed to erect the walls, including the proposed leveling pad elevations; the type and details of the soil reinforcing system (if applicable); the details and manufacturer of all pads, fillers, and filter fabric; the limits and dimensions of structural backfill; details necessary to incorporate coping, railing, inlets, drainage, and electrical conduit; and additional necessary details.
- Leveling pad elevations may vary from the elevations shown on the plans. Provide at least 1 ft. of cover from the top of the leveling pad to finish grade unless a different minimum cover or a specified minimum leveling pad elevation is shown.
- 3.3.3. **Design Calculations.** Include calculations covering the range of heights and loading conditions on the project. Calculations for both internal and external stability as described on the plans will be required. Include a summary of all design parameters used; material types, strength values, and assumed allowables; loads and loading combinations; and factor-of-safety parameters.
- 3.4. **Permanent MSE Walls.** Grade the foundation for the structure level to a width equal or exceeding the length of the reinforcing system. Perform proof rolling on retaining wall foundation area to identify any loose, soft, or unsuitable materials in accordance with Item 216, "Proof Rolling." Material not meeting a maximum rut depth of 1 in. per pass of pneumatic tire roller should continue to be rolled or removed and replaced with suitable material. Pneumatic tire rolling will be waived for portions of wall with a reinforcement length of 8'; for these conditions proof rolling will be required with a smooth-wheeled vibratory roller or other approved roller.
- Place drilled shafts and piling located within the MSE volume before construction of the wall. Place any required pipe underdrain before construction of the wall. Complete MSE wall construction before construction of abutment caps and abutment wing walls. Completion of walls and abutment should be in conjunction with project phasing or to allow for completion of walls that meets the proper placement and compaction at abutments.
- Place the concrete leveling pad as shown on the construction drawings. Provide a wood float finish, and wait a minimum of 24 hr. before beginning panel erection. No curing or strength testing of the leveling pad concrete is required.
- Shim the first row of panels as necessary to achieve correct alignment. Use plastic shims or other material that will not deteriorate. Remove and replace the leveling pad or provide a grout level-up as directed if the required shim height exceeds 1 in.
- Place filter fabric behind the wall along the joint between the leveling pad and the panels. Grout areas where filter fabric spans more than 6 in. at leveling pad steps.

Place and compact fill material over the leveling pad to an elevation even with or above the surrounding ground after backfilling the first row of panels. Do not allow water to accumulate and stand at the base of the wall.

Place filter fabric behind all wall joints and at the intersection of retaining walls with other structures, including riprap. Cover joints at least 6 in. on each side and use adhesive to hold the filter fabric in place.

Exercise care while lifting, setting, and aligning panels to prevent damage to the panels. Discontinue any operation that results in chipping, spalling, or cracking of panels. Remove and replace damaged panels, or repair as approved by the Engineer.

Provide external bracing for the initial row of panels. Use wooden wedges, clamps, or other means necessary to maintain position and stability of panels during placement and compaction of backfill. Remove wooden wedges as soon as the panel or coping above the wedged element is erected and backfilled. Remove all wedges after completing the wall.

Review plumbness and position of each row of panels before placing the subsequent row. Remove and rebuild any portion of the wall that is out of tolerance. Modify panel batter and bracing, and backfill material, placement, and compaction methods as required to maintain wall tolerances.

Construct walls to a local vertical and horizontal alignment tolerance of 3/4 in. when measured along a 10-ft. straightedge relative to vertical and horizontal wall control line. Construct walls to an overall vertical tolerance (plumbness from top to bottom) of 1/2 in. per 10 ft. of wall height. Construct walls so the maximum offset at any panel joint is between 3/8 in. and 3/4 in. and no joint is open to the extent the filter fabric is visible from the front of the wall.

Place backfill to closely follow the erection of each row of panels. Place the select and embankment backfill to the same elevation where possible, and operate the compaction equipment over the interface. Do not create a continuous, distinct, vertical joint between the select and embankment backfill. Complete the embankment after construction of the retaining wall.

Maintain the stability of the interface area between the existing ground and the select fill when building a wall against existing ground. Remove and recompact any material that loosens, caves, or fails.

Compact backfill to provide at least 95% of density determined in accordance with Tex-114-E. Field density determination will be made in accordance with Tex-115-E.

Sprinkle backfill as required to ensure adequate uniformly distributed moisture in each lift before and during compaction. Place fill in lifts of 8 in. or less (loose measurement). Place fill in a manner that avoids segregation of the fill. Decrease the lift thickness if necessary to obtain the required compaction. Use hand-operated or walk-behind compaction equipment in the 3 ft. wide strip adjacent to the wall panels. Do not displace panels or distort or damage the reinforcement system during compaction. Modify backfill material, placement, and compaction methods as necessary to meet density requirements while maintaining wall tolerances.

Place rock backfill or material the Engineer determines too coarse for density testing in accordance with Section 132.3.4.1., "Ordinary Compaction."

Place and compact the backfill to the reinforcement level, at each earth reinforcement level, before placing the reinforcement. Place earth reinforcements perpendicular to the face of the wall. Remove slack in connections before placing backfill. Pre-tension each layer of reinforcement to remove slack before placing backfill for systems using nonmetallic earth reinforcements. Use devices capable of mechanically applying and holding the required force. Do not operate tracked equipment directly on any reinforcement.

Cover the rock backfill with filter fabric before placing the 2 ft. of backfill immediately below the pavement structure or top of wall when rock backfill is used. Overlap the fabric at least 18 in. at splices, and extend it past the edge of the rock backfill at least 18 in. Use backfill that contains sufficient fines to fill the voids in a

compacted state above the filter fabric. Place a horizontal layer of filter fabric as noted above when transitioning from rock backfill to finer grained backfill anywhere within the wall volume.

Prevent surface water or rainwater from damaging the retaining walls during construction. Shape the backfill to prevent water from ponding or flowing on the backfill or against the wall face. Remove and replace any portion of the retaining wall damaged or moved out of tolerance by erosion, sloughing, or saturation of the retaining wall or embankment backfill.

- 3.5. **Temporary MSE Walls.** Provide a facing system rigid enough to maintain a smooth and straight wall face both during and after construction.

Grade and compact the foundation for the structure as described in Section 423.3.4., "Permanent MSE Walls."

Place earth reinforcement and facing system in accordance with the approved working drawings. Backfill the 2-ft. zone immediately behind the facing with clean, coarse rock meeting the requirements of Coarse Aggregate Grade 1, 2, or 3 of Item 421, "Hydraulic Cement Concrete," or of Type DS backfill as described in Section 423.2.4.2., "Select." Cement-stabilized backfill as described in Section 423.2.4.4., "Cement-Stabilized Backfill," may be used in place of the coarse rock.

Place and compact backfill in accordance with Section 423.3.4., "Permanent MSE Walls."

Construct walls to a vertical and horizontal alignment tolerance of 3 in. when measured along a 10-ft. straightedge. Construct walls to an overall vertical tolerance (plumbness from top to bottom) of 2 in. per 10 ft. of wall height. Place adjacent facing elements so the maximum out-of-plane offset at any facing element joint is less than 1 in. Place facing elements and filter fabric with no gaps in the facing or fabric.

Prevent surface water or rainwater from damaging the retaining walls during and after construction. Place temporary berms or curbs, shape the backfill, or use other approved methods to prevent water from flowing against or over the wall face. Remove and replace any portion of the wall damaged or moved out of tolerance by erosion, sloughing, or saturation of the retaining wall or embankment backfill.

- 3.6. **Concrete Block Retaining Walls.** The concrete block units may be sampled and tested by the Engineer before shipment or upon delivery to the construction site. Display for approval, samples of block units indicating the color, texture, and finish. Store, transport, and handle all block units carefully to prevent cracking or damage.

Grade and compact the foundation for the structure, and place the leveling pad as described in Section 423.3.4., "Permanent MSE Walls."

Place the concrete block facing units in accordance with the approved working drawings. Fill the voids within the units and fill the 1-ft. zone immediately behind the facing with drainage aggregate as described in Section 423.2.4.3., "Drainage Aggregate." Systems tested without unit fill may omit the fill as indicated on the approved drawings. Systems with approved filter fabric details may omit the drainage aggregate in the 1-ft. zone immediately behind the facing.

Place reinforcements and backfill for walls using earth reinforcements in accordance with the requirements of Section 423.3.4., "Permanent MSE Walls." Pay particular attention to the connection details of the earth reinforcements to the concrete block units.

Construct walls to a vertical and horizontal alignment tolerance of 1-1/2 in. when measured along a 10-ft. straightedge. Construct walls to an overall vertical tolerance (deviation from the vertical or battered control line, top to bottom) of 1 in. per 10 feet of wall height. Place adjacent facing elements so the maximum out-of-plane offset at any facing element joint is less than 1 in. Place facing elements with maximum 1/4-in. gaps between block units.

Prevent surface water or rainwater from damaging the retaining walls during construction. Shape the backfill to prevent water from ponding or flowing on the backfill or against the wall face. Remove and replace all portions of the retaining wall damaged or moved out of tolerance by erosion, sloughing, or saturation of the retaining wall or embankment backfill.

4. MEASUREMENT

This Item will be measured by the square foot of the front surface area of the wall. Unless otherwise shown on the plans, the area will be measured from 1 ft. below finished grade of the ground line on the face of the exterior wall to the top of the wall including any coping required (not including railing).

This is a plans quantity measurement Item. The quantity to be paid is the quantity shown in the proposal unless modified by Article 9.2., "Plans Quantity Measurement." Additional measurements or calculations will be made if adjustments of quantities are required.

5. PAYMENT

The work performed and materials furnished in accordance with this Item and measured as provided under "Measurement" will be paid for at the unit price bid for "Retaining Walls" of the type or special surface finish specified. This price is full compensation for excavation in back of retaining walls and for footings; furnishing and placing footings, leveling pads, copings, and traffic railing foundations; furnishing, placing, and compacting backfill (except in embankment areas), including cement for stabilization; proof rolling; furnishing and placing concrete, reinforcing steel, waterproofing material, filter material and drain pipe, joint material, water stop, and filter fabric when required; fabricating, curing, and finishing all panels; furnishing and placing earth reinforcement, anchorage systems, and fasteners; wall erection; and equipment, labor, tools, and incidentals.

Retaining wall backfill areas that are also in embankment areas will be considered part of the quantities measured and paid for under Item 132, "Embankment."

When drilled shafts are required, they will be measured and paid for as specified in Item 416, "Drilled Shaft Foundations." When piling is required, it will be measured and paid for as specified on the plans for piling of the appropriate type.

Item 424

Precast Concrete Structural Members (Fabrication)



1. DESCRIPTION

Fabricate precast prestressed and precast nonstressed concrete members. This Item, in conjunction with DMS-7300, "Precast Concrete Fabrication Plants," applies to both multi-project and project-specific fabrication plants. For this Item, the following definitions apply:

- **Prestressing.** The introduction of internal stresses (pre-tensioning or post-tensioning) into a structural member by tensioning and anchoring strands, bars, or wires to counteract the stresses resulting from the applied load.
- **Pre-Tensioning.** The application of prestressing force to the tensioning devices before casting concrete.
- **Post-Tensioning.** The application of prestressing force to the tensioning devices after concrete has hardened.
- **Tendon.** Any single unit used to apply prestressing force to the member. For post-tensioned units, a tendon is a bar, group of wires, or group of strands with common end anchorage.
- **Multi-Project Fabrication Plant.** A facility at an offsite location that fabricates precast prestressed or precast nonstressed members. This definition also applies to single Contract offsite facilities.
- **Project-Specific Fabrication Plant.** A temporary facility at or near the project location that fabricates precast prestressed or precast nonstressed members for only one Contract. This definition may be applied to temporary facilities that fabricate for multiple Contracts, if approved.
- **Nonstressed Members.** Precast concrete members that have not been pre-tensioned or post-tensioned.
- **Prestressed Members.** Precast concrete members fabricated by the process of pre-tensioning, post-tensioning, or a combination of both methods.
- **Minor Prestressed Members.** Includes piling, bridge deck panels, and sound wall panels.
- **Major Prestressed Members.** Includes all other prestressed members not listed as minor prestressed members.
- **I-Beams.** For this specification all I-girders and bulb-tee beams are referred to as I-beams.
- **Self-Consolidating Concrete (SCC).** A highly workable concrete that can flow through densely reinforced or complex structural elements under its own weight and adequately fill voids without segregation or excessive bleeding without the need for vibration.
- **Temperature Probe.** Thermocouple for measuring concrete temperature or air temperature.
- **Temperature Recording Device.** Data logger for recording temperatures from the temperature probes.

2. EQUIPMENT

- 2.1. **Field Office and Inspection Laboratory.** Provide a field office and inspection laboratory for multi-project and project-specific fabrication plants in accordance with DMS-7300, "Precast Concrete Fabrication Plants."
- 2.2. **Furnishings and Laboratory Equipment.** Provide furnishings and laboratory equipment for multi-project and project-specific fabrication plants in accordance with DMS-7300, "Precast Concrete Fabrication Plants."
- 2.3. **Plant Facilities.** Provide plant facilities for multi-project and project-specific fabrication plants that produce prestressed members in accordance with DMS-7300, "Precast Concrete Fabrication Plants."

- 2.4. **Batch Plant.** Provide batch plant onsite for SCC construction unless otherwise approved. Do not use volumetric mixers for SCC.

3. MATERIALS

Furnish materials in accordance with Item 425, "Precast Prestressed Concrete Structural Members," and other pertinent Items.

4. CONSTRUCTION

4.1. General Requirements.

- 4.1.1. **Shop Drawings.** Prepare and electronically submit shop drawings before fabrication as documented in the *Guide to Electronic Shop Drawing Submittal* available on the Bridge Division website. Provide one complete approved 11 × 17-in. set in hardcopy to the Department inspector at the fabrication plant. Stamp it "For Construction Division Inspector." The Engineer may require additional complete hardcopy sets.

Provide a title block on each sheet in the lower right corner with the following information:

- sheet index data shown on lower right corner of the project plans,
- sheet numbering for shop drawings,
- name of structure or stream,
- name of owner or developer,
- name of fabricator or supplier, and
- name of Contractor.

- 4.1.1.1. **Prestressed Members.** Furnish shop drawings for prestressed members unless otherwise shown on the plans or in other Items. Submit the proposed designs on forms furnished by the Department when optional designs are permitted by the plans. Obtain approval of these designs before casting. Approval of optional designs does not relieve the Contractor from the responsibility of furnishing a satisfactory completed structure. Provide submittals for precast post-tensioned members in accordance with this specification and Item 426, "Post-Tensioning."

- 4.1.1.2. **Nonstressed Members.** Furnish shop drawings for nonstressed members when required by the plans or pertinent Items.

4.1.2. Plant Approval.

- 4.1.2.1. **Plant Submittals.** Provide submittals in accordance with DMS-7300, "Precast Concrete Fabrication Plants," for each particular plant operation. This requirement does not apply to project-specific nonstressed member fabrication plants.

- 4.1.2.2. **Plant Audits.** Multi-project and project-specific fabrication plants must pass initial and periodic Department-directed plant audits in accordance with DMS-7300, "Precast Concrete Fabrication Plants."

- 4.1.3. **Notice of Beginning Work.** Give adequate notice before beginning work as specified in Table 1. Include a schedule for all fabrication processes and dates when inspections are to occur.

**Table 1
Notice of Beginning Work**

Plant Location	Notice Required
In Texas	7 days
In the contiguous United States	21 days
Outside the contiguous United States	60 days

Perform no Department work in the plant before the Engineer authorizes fabrication. The Contractor must bear all Department travel costs when changes to their fabrication or inspection schedules are not

adequately conveyed to the Department. When fabrication is performed outside of the contiguous 48 states, the additional cost of inspection will be in accordance with Article 6.4., "Sampling, Testing, and Inspection."

- 4.1.4. **Personnel Qualifications.** Provide qualified personnel in accordance with DMS-7300, "Precast Concrete Fabrication Plants," for each particular plant operation.
- 4.1.5. **Quality Responsibilities.** The quality responsibilities for the Contractor for each particular plant operation will be in accordance with DMS-7300, "Precast Concrete Fabrication Plants."
- 4.2. **Fabrication.** Prepare a casting schedule on Department-approved forms per DMS-7300, "Precast Concrete Fabrication Plants," and submit it daily to the Department before fabrication. This requirement does not apply to project-specific minor prestressed member or project-specific nonstressed member fabrication plants. Perform fabrication during daylight hours unless the production site has an approved lighting system. Submit lighting details electronically to the Engineer for review before installing lighting system. Allow for plant and Department inspection in accordance with Item 6, "Control of Materials."
- 4.2.1. **Forms.** Design forms to prevent damage to the concrete from restraint as the concrete shrinks, from form expansion and contraction from thermal changes, from stripping operations, and from dimensional changes due to pre-tensioning. Forms, regardless of material, must conform to the profiles, dimensions, and tolerances of the finished product as specified on the plans and in this Item. Maintain forms free from dents, grease, or other foreign materials that may affect the appearance of the member, and clean forms thoroughly before each casting operation and immediately before applying a form-release agent.
- 4.2.1.1. **External Forms.** Construct side and bottom forms of steel unless otherwise approved or noted on the plans. Timber forms, when permitted, must meet the requirements of Section 420.4.4., "Forms." End headers may be of other material as approved.

Construct forms with sufficient thickness, external bracing and stiffeners, and anchorage to withstand the forces generated during concrete placement and consolidation. Do not stabilize forms with bracing and holding devices that will remain in the finished member.

Provide corners with a chamfer or radius where shown on the plans.

Maintain forms sufficiently mortar-tight to prevent damage that requires repair to the finished product. Where sections of forms will be joined, an offset of 1/16 in. for flat surfaces and 1/8 in. for corners and bends is permitted. Longitudinal form joints in prestressed concrete beams are not permitted except for in the side forms of slab beams, decked slab beams, box beams, and X-beams or as shown on the plans. Do not allow vertical or horizontal gaps or offsets to exceed 1/4 in. between adjacent sections of built-up end headers.

Check the grade and alignment of forms each time they are set, and maintain them during placement of concrete.

Apply a form-release agent, in accordance with the manufacturer's recommendations, to the facing of forms before placing concrete. Use a form-release agent that facilitates form removal and does not affect any required coating, painting, or color-staining operations. Do not use materials that appreciably stain or react with the concrete. Remove excess form-release agent from the form surface before casting, and ensure it does not contaminate strands, reinforcing steel, and embedments. Use a clear form-release agent of the same brand throughout the casting of retaining wall panels per structure, unless it can be shown that a different form-release agent does not change the appearance of the concrete.

Construct the forms to facilitate removal of members without damage to the concrete.

Construct and maintain the soffit (liner) to provide a maximum 1/4 in. variation from the theoretical plane, and do not allow the soffit to vary more than 1/4 in. between any 2 points in any 50-ft. length.

At the Contractor's option, construct side forms for bridge deck panels and prestressed piling with a draft for ease of product removal. Maintain product dimensional tolerances per Table 3. A maximum 1/4 in. draft is allowed for bridge deck panels.

- 4.2.1.2. **Internal Forms.** Use solid expanded polystyrene conforming to ASTM C578 Type I for forming internal voids. The form material must be inert, non-biodegradable, non-absorptive, and strong enough to maintain sufficient rigidity to withstand the forces generated during concrete placement and consolidation without damage. Other materials for forming internal voids may be used when approved. Provide certification of conformance for void forms. The Engineer may require samples to be submitted when needed.

Anchor internal void forms to prevent movement or misalignment while placing concrete. Provide hold-down devices for all types of void forms at 30-in. maximum spacing unless otherwise approved. Do not use internal hold-down or lateral bracing devices that will remain in the finished member unless approved. Provide enough bearing area on the void form to prevent penetration of hold-down devices into the void form. Splice void form sections to prevent separation or misalignment during concrete placement and consolidation operations.

During casting, verify and document void form placement at 10-ft. maximum spacing using an approved method.

Vent void forms without solid cores to eliminate high air pressure caused by heat of hydration. Insert a 3/4-in. diameter plastic tube into the top of the void before placing concrete, and leave it in place until there is no possibility of damage from pressure. Remove the plastic tube afterwards and seal the hole with an approved repair material and procedure.

Drain prestressed concrete box beams and U-beams through the bottom flange by forming holes in each voided area as shown on the plans.

- 4.2.2. **Prestressing.** Perform pre-tensioning in accordance with this Item and post-tensioning in accordance with Item 426, "Post-Tensioning."

- 4.2.2.1. **Prestressing Equipment.** Furnish hydraulic jacks with sufficient capacity for prestressing the steel. Equip the jacks with instruments for monitoring the hydraulic pressure. Provide gauges at least 6 in. in diameter and with means to prevent the gauge pointer from fluctuating. Electronic pressure transducers with digital indicators may be used. Pressure gauges or electronic pressure indicators must indicate the load directly to 1% of the maximum gauge or sensor/indicator capacity or 2% of the maximum load applied, whichever is smaller.

Calibrate each jack and its gauge with the cylinder extension in the approximate position at final jacking force. Jacks and gauges for post-tensioning and single-strand pre-tensioning must be calibrated as a unit. Have certified calibration charts furnished by an independent laboratory and with each jack and gauge used on the project. Provide certified calibration of each ram before starting stressing operations on the project and:

- every 6 mo. thereafter for post-tensioning operations,
- every 12 mo. thereafter for pre-tensioning operations, and as requested by the Engineer.

The calibration frequency for multiple-strand pre-tensioning equipment may be extended to every 24 mo. thereafter if an approved master gauge system monitors it. The master gauge must check this equipment when suspect results occur and at least every 6 mo. Calibrate the master gauge per the manufacturer's recommendations and at least every 12 mo.

Recalibrate jacks and gauges when a malfunction occurs, when repairs such as replacing the seals, changing the length of the hydraulic lines, or changing the pump occur, or when using gauges that have not been calibrated with the jack. Extra compensation will not be allowed for the initial or subsequent calibrations.

Post-tensioning jacks must have provisions for measuring tendon elongation directly on the strand, bar, or wire. The jacks must be capable of slow release of force to properly seat the tendon anchors.

Single-strand stressing jacks for pre-tensioning must have provisions for measuring the elongation directly on the strand.

Multi-strand detensioning jacks must have sufficient capacity and throw to permit simultaneous release of the entire load in the strands. Use an approved single-strand flame-release procedure to release the remaining load if there is not enough throw in the multi-strand jacks to release all load in the strands.

4.2.2.2.

Pre-Tensioning. Pre-tension all strands to a uniform initial load between 5% and 25% of the final load unless otherwise approved. Apply the load within a tolerance of:

- ± 100 lb. per strand if the designated initial load is less than or equal to 10% of the final load, or
- ± 200 lb. per strand if the designated initial load is greater than 10% of the final load.

Measure the initial load with a calibrated dynamometer or other suitable equipment.

Do not allow the modulus of elasticity of individual strands to vary more than 1% from each other when multiple-strand tensioned. Use a weighted average modulus of elasticity of strands to calculate elongation for multiple-strand tensioning operations.

Establish reference marks on the strand for measuring elongation after initial tensioning. Provide means for measuring the elongation of the strand to an accuracy of 1% of the theoretical elongation or 1/8 in., whichever is smaller. Establish independent references on the strand adjacent to each anchorage, to indicate slippage that may occur between the time of initial stressing and final release of the strands.

Do not allow the stress in the strand to exceed 80% of the specified ultimate tensile strength of the strand at any time.

Do not use any portion of the strand that has been previously gripped with chucks in the length of strand to be tensioned, except where gripped with chucks during initial tensioning. Do not drive over prestressing strand.

Strand chucks designed with spring caps must be used with the spring caps. Visually inspect strand chucks that are not equipped with spring caps to ensure all wedges are evenly seated after applying initial load. Correct unevenly seated wedges by releasing the stress, repositioning wedges, and reapplying the initial load.

Failure of individual wires in a 7-wire strand is acceptable if the total area of wire failure is not more than 2% of the total cross-sectional area of all strands in the member, and if no more than 1 wire fails in any single strand. Any setup with one or more broken wires must be examined by a licensed professional engineer or Quality Control Supervisor (as defined in DMS-7300, "Precast Concrete Fabrication Plants,") to determine the cause before continuing stressing operations on the particular casting line.

4.2.2.2.1.

Strand Splicing. Do not splice draped strands. One splice per straight strand will be permitted subject to the following:

- Locate splices outside the members.
- Splice strands with the lay or twist in the same direction to avoid unraveling.
- Splice all straight strands in a multiple-strand tensioning operation so an adjustment can be made for the average seating loss.
- Cut strand ends to be spliced with shears, abrasive saws, or grinders to remove regions where chucks were previously seated. Cut in the same manner at least 12 in. from strand ends to be spliced that were previously flame cut.

- 4.2.2.2.2. **Single and Multiple Straight Strand Tensioning.** After initial tensioning, apply the required load to the strands as shown on the plans by means of single-strand or multiple-strand hydraulic jacks equipped with calibrated gauges. Verify the final load in the strands by observing either the gauge pressure or elongation and independently checking the other. The final load and elongation must agree within 5% of the computed theoretical values. Additionally, the final load and elongation must agree algebraically with each other within 5%. Suspend tensioning operations until the problem has been identified and corrected in the event of discrepancies greater than these tolerances.
- Verify uniform application of load to strands for multiple-strand-tensioning systems by measuring the movement on opposite sides of the anchorage.
- 4.2.2.2.3. **Draped Strand Tensioning.** Verify the intermediate load by observing either the gauge pressure or elongation and independently checking the other when draped strands are tensioned in a straight or partially-draped position before application of final load. The intermediate or final load, if strands are tensioned in the final position and elongation must agree within 5% of the computed theoretical values. Additionally, the intermediate or final load and elongation must agree algebraically with each other within 5%. Suspend tensioning operations until the problem has been identified and corrected in the event of discrepancies greater than these tolerances.
- After application of final load, measurements on individual draped strands to establish differential stresses at selected points on the member will be averaged at a cross-section of the member, and the averages must be within 5% of the theoretical elongation. The measured elongation of any individual draped strand must not vary from the theoretical elongation by more than 10% at any measured cross-section. Suspend tensioning operations until the problem has been identified and corrected in the event of discrepancies greater than these tolerances.
- Other methods to measure the intermediate load and final load in the draped strands may be submitted for approval.
- 4.2.2.2.4. **Strand Debonding.** Encase strands in plastic sheathing along the entire debonded length, and seal the ends with waterproof tape when shown on the plans. Use split plastic sheathing only if the seam is sufficiently sealed with waterproof tape to prohibit grout infiltration. Do not use sheathing that will permanently alter the physical or chemical properties of the surrounding concrete.
- Full-length debonding of straight strands will be approved on an individual basis. Full-length debonding, when permitted, must be symmetrical about the vertical centerline of the beam and limited to 10% of the total number of straight strands or 6 straight strands, whichever is less. Do not debond draped strands full length. When using a concrete anchor block to combined strand patterns the same criteria applies.
- 4.2.2.3. **Combined Pre-Tensioning and Post-Tensioning.** When the plans call for a combination of pre-tensioning and post-tensioning, all of the requirements for pre-tensioning in this specification and for post-tensioning in Item 426, "Post-Tensioning," apply.
- 4.2.3. **Placing Reinforcing Steel.** Place reinforcing steel in accordance with Item 440, "Reinforcement for Concrete." Reinforcing steel projection outside of the member must not be more than 1/2 in. or less than 3/4 in. from plan dimension unless otherwise approved. Do not damage sheathing for strand debonding. Do not tie reinforcing steel to debonded strand regions.
- Weld steel components in accordance with Item 448, "Structural Field Welding." Provide welding procedure specifications (WPSs) for approval, and welding personnel certifications per the applicable AWS code.
- 4.2.4. **Quality of Concrete.** Provide concrete in accordance with Item 421, "Hydraulic Cement Concrete." Use the class of concrete shown on the plans or in the pertinent Item for each type of structure or unit. Provide concrete meeting the approved mix design water-cement ratio. SCC is not allowed for project-specific fabrication plants unless approved by the Engineer. Mix concrete for a period of 1 min. for 1 cu. yd. and 15 sec. for each additional cu. yd. of rated capacity of the mixer. Count the mixing time from the time all materials are in the drum. Increase mixing time if necessary to achieve a uniform mix. Control concrete by

compressive strength tests of cylinders or other pertinent performance tests detailed on the plans or pertinent items. Concrete compressive-strength test cylinders will be made, cured, and tested in accordance with Tex-704-I. Cure release-of-tension strength cylinders in accordance with Tex-715-I when match-cure technology is used.

High-strength concrete ($f'_c > 9,000$ psi) is accepted based on 56-day compressive strength testing. Concrete design-strength test cylinders for high-strength concrete will be made, cured, and tested in accordance with Tex-704-I.

Product with concrete that fails to meet minimum design compressive strength requirements will be reviewed. Concrete that has been determined to be structurally adequate may be accepted at an adjusted price based on the formula in Article 421.6., "Measurement and Payment." If the Engineer requires cores be taken to determine the strength of the in-situ concrete, the coring will be at the Contractor's expense and in accordance with Tex-424-A. All cores from precast members must meet 100% of the minimum design compressive strength requirements. For concrete that has been determined to be structurally adequate, coring of the in-situ concrete will not be allowed for the purpose of avoiding the price adjustment. The Department may require reimbursement for testing of cores. Testing by an approved commercial testing laboratory will be at the Contractor's expense. Test results from a commercial laboratory must be sealed by a licensed professional engineer.

SCC used for prestressed beams must have a Modulus of Elasticity of 5,000 ksi at 28 days. Test the concrete mix design before use in accordance with ASTM C469.

4.2.5. **Placing Concrete.** Place concrete only when its temperature at time of placement is between 50°F and 95°F.

Take responsibility for producing quality concrete under any weather condition and ensure adequate weather protection provisions are on-site and available for immediate use.

Provide immediate protective measures without compromising the quality of the product if rainfall occurs after concrete placing operations have started. Failure to immediately provide adequate weather protection may be cause for rejection of the affected product.

Maintain concrete transporting equipment clean and free from hardened concrete coatings.

At the time of concrete placement, reinforcing steel, strands, and embedments must be free of dirt, oil, or other bond-breaking substances.

Place and adequately consolidate concrete while all lifts are in a plastic state. Concrete must not exhibit segregation or excessive bleeding. Minimize concrete flow lines and displacement of the reinforcing steel, strands, embedments, and ducts during concrete placement. Concrete must not exhibit segregation or excessive bleeding.

Place concrete as near as possible to its final position in the forms except when using SCC. Do not deposit large quantities of concrete at one location and run or work it along the forms to other locations except for SCC. Place SCC in a manner to avoid segregation.

Do not allow fresh concrete to free-fall more than 8 ft. unless approved.

Work the coarse aggregate back from the face of the concrete, and force the concrete under and around the reinforcing steel, strands, embedments, and ducts. If prestressed concrete I-beams are cast in multiple lifts, the thickness of the first lift must be slightly above the juncture of the bottom flange and web.

Cast prestressed concrete box beams monolithically in 2 stages, maintaining the concrete in the previously placed bottom slab in a plastic state until the web (side wall) concrete is placed and vibrated into the bottom slab unless approved by the Engineer.

The maximum time between the addition of mixing water or cement to the concrete batch and the placing of concrete in the forms is 30 min. for concrete delivered in non-agitated delivery equipment and 60 min. for concrete delivered in agitated delivery equipment. If conditions of wind, humidity, and temperature cause quick stiffening of the concrete, the required placement times may be reduced and an approved retarder may be required, or increased if currently in use. Submit a plan for approval, if necessary, to demonstrate the concrete can be properly placed, consolidated, and finished without reducing placement time limits.

The maximum acceptable placement slump will be in accordance with Item 421, "Hydraulic Cement Concrete," unless otherwise specified. When the maximum acceptable placement slump or slumpflow is exceeded, the affected concrete will be rejected and retesting for slump or slumpflow will not be allowed regardless of the concrete placement times.

Additional requirements for precast mass placements will be in accordance with Item 420, "Concrete Substructures." In the case of a conflict between the 2 Items the more stringent requirements apply.

4.2.5.1.

Placing Concrete in Cold Weather. Maintain concrete temperature between 50°F and 95°F at time of placement as specified in Section 424.4.2.5., "Placing Concrete," and maintain the concrete temperature of precast members at or above 50°F during the specified curing period as specified in Section 424.4.2.7., "Curing of Concrete." Do not place concrete when the atmospheric temperature in the shade is below 40°F and falling unless approved. Concrete may be placed when the atmospheric temperature in the shade is at least 35°F and rising or above 40°F, provided adequate cold-weather protection provisions are on-site and available for immediate use before placing concrete when weather conditions indicate a possible need for temperature protection. When required, provide necessary covering material or an approved accelerated curing system in accordance with Section 424.4.2.7.4., "Accelerated Curing," and do not allow any concrete to remain unprotected for longer than 1 hr. after placement. Do not place concrete in contact with any material coated with frost or with material at a temperature of 32°F or lower. Do not apply heat directly to concrete surfaces if accelerated curing is used. Take protective measures to ensure the difference between air temperature and concrete surface temperature does not cause thermal cracking.

Maintain aggregates free from ice, frost, and frozen lumps. Heat the aggregate and the water when needed to produce the minimum concrete placement temperature of 50°F, but:

- do not allow the water temperature to exceed 180°F or the aggregate temperature to exceed 150°F,
- heat the aggregate uniformly to eliminate overheated areas in the stockpile that might cause flash set of the cement, and
- provide an aggregate and water mixture temperature between 50°F and 85°F before introduction of the cement.

4.2.5.2.

Placing Concrete in Hot Weather. Keep concrete at or below 95°F at time of placement in accordance with Section 424.4.2.5., "Placing Concrete." Use any of the following methods, as needed, to control the concrete placement temperature:

- Cool the aggregate by sprinkling or fogging (fine mist) with water, shading, or using an approved liquid nitrogen system and procedure.
- Cool the fresh concrete by using chilled mixing water, partially replacing mixing water with shaved or crushed ice, or using an approved system and procedure to discharge liquid nitrogen into concrete during batching.

Apply a fog spray (fine mist) of water to this steel just before placing concrete when the temperature of steel forms, strand, or reinforcing steel is greater than 120°F. Water droplets left on the form surfaces must not adversely affect surface finishes.

When field conditions are such that evaporation of water from the concrete makes the surface finishing operation difficult, a fog spray (fine mist) of water may be applied above the concrete surface. Do not fog directly toward the concrete or in any manner that will wash cement paste from the fresh concrete surface or cause water to puddle. Do not fog as a means to add finishing water and do not work moisture from the fog spray into the fresh concrete. An approved evaporation retardant conforming to DMS-4650, "Hydraulic

Cement Concrete Curing Materials and Evaporation Retardants,” is also acceptable if used in accordance with the manufacturer’s recommendations. Do not apply the evaporation retardant when floating and troweling concrete. Do not allow it to puddle or be worked into the concrete surface immediately after application. Misuse of fog spray or evaporation retardant will be cause for disallowing its use. Shade the concrete during casting if necessary.

Use an approved retarder, in accordance with the manufacturer’s recommendations, when the air temperature is above 85°F if necessary to control concrete slump loss and lengthen the time for placing, consolidating, and finishing operations.

- 4.2.5.3. **Consolidation of Concrete.** Consolidate concrete thoroughly with high-frequency vibration immediately after placement. For prestressed concrete beams and piling, internal vibration is required and may be supplemented with external vibration.

Provide at least 1 on-site standby vibrator of the type being used for emergency use.

Perform concrete vibration using trained personnel and proper timing and spacing to ensure adequate consolidation. Revise the concrete placement and consolidation procedures, and review the concrete mix design and batching procedures, if necessary, when unacceptable defects such as excessive honeycombing, aggregate or mortar pockets or surface air voids (bugholes) are present. Provide supplemental vibrators or modify the vibration system when required to accomplish thorough consolidation of the concrete and complete embedment of the strands, reinforcing steel, embedments, or ducts. Avoid segregation or excessive bleeding of the concrete during vibration.

- 4.2.5.3.1. **Internal Vibration.** Insert vibrators into the concrete immediately after concrete placement at points spaced to ensure uniform vibration of the entire concrete mass. Limit the insertion spacing to within the radius where the vibrators are visibly effective. Allow the vibrators to sink into the concrete by their own weight and penetrate into previously placed lifts that are still in a plastic state to thoroughly consolidate the layers together and prevent cold joints. Withdraw the vibrators slowly to avoid forming holes after the concrete is thoroughly consolidated.

Do not allow prolonged contact of vibrators with forms so vibrator marks on concrete surfaces are minimal. Do not use vibrators to move concrete to other locations in the forms.

Use vibrators with nonmetallic vibrating heads to prevent damage to the epoxy coating when epoxy coated reinforcing steel is used. Increase the consolidation time and decrease the insertion spacing, if necessary, when using these vibrators.

- 4.2.5.3.2. **External Vibration.**

- 4.2.5.3.2.1. **Form Vibrators.** Form vibrators may be used to consolidate thin members, supplement internal vibration, or consolidate members with highly congested reinforcing steel.

Determine the size, number, and location of external vibrators to provide enough intensity of vibration to the desired area of the form. Adjust the spacing, frequency, amplitude, and duration of vibration according to the concrete mix and size of member to produce uniform consolidation of the concrete.

- 4.2.5.3.2.2. **Surface Vibrators.** Use vibratory screeds to consolidate thin sections. Move vibratory screeds at a rate that will bring enough mortar to the surface to embed and cover the coarse aggregate. Do not over vibrate by causing an excessive amount of mortar to be brought to the surface.

- 4.2.5.3.2.3. **Vibrating Tables.** Determine the size, number, and location of external vibrators to provide enough intensity of vibration to the desired area of the form. Adjust the spacing, frequency, amplitude, and duration of vibration according to the concrete mix and size of member to produce uniform consolidation of the concrete.

- 4.2.5.3.3. **Vibration of Self-Consolidating Concrete (SCC).** Vibrate SCC only when approved by the Engineer. Provide an adequate amount of viscosity modifying admixture (VMA) in SCC mix when internal vibration is allowed by the Engineer.
- 4.2.6. **Finishing of Concrete.** Finished, unformed surfaces must not have distortions greater than 1/4 in. Scream or rough-float unformed surfaces of members, bringing enough mortar to the surface to embed and cover the coarse aggregate. Provide a uniform rough wood float finish to the surface of the member unless otherwise shown on the plans. Do not loosen aggregate when roughening the surface with a broom or when providing a trowel finish.
- Provide a smooth metal trowel finish for surfaces at anchor bolt locations.
- 4.2.7. **Curing of Concrete.** Cure concrete to promote early cement hydration by providing adequate moisture on exposed surfaces and by maintaining the concrete temperature or curing enclosure air temperature at the concrete surface within the limits specified in this Section. Provide uniform temperature and moisture on the surfaces to prevent differential shrinkage that may cause warping or cracking. Prevent temperature differentials within the concrete that cause thermal cracking.

Begin curing after the finishing operation, before the formation of plastic shrinkage cracks, and as soon as damage to the surface finish will not occur. Provide fog spray or an evaporation retardant after finishing and before curing if needed to prevent plastic shrinkage cracks. Apply fog spray or evaporation retardant in accordance with Section 424.4.2.5.2., "Placing Concrete in Hot Weather." Keep exposed concrete surfaces continuously wet for the duration of the specified curing period, unless an approved liquid membrane-forming curing compound is used. Membrane curing compound is only permitted as noted in this Section or in the pertinent Item.

Approved equipment and materials for curing must be on-site and available for immediate use before placing concrete. Provide temperature probes to monitor the concrete temperature or curing enclosure air temperature as specified in Table 2.

Table 2
Temperature Probe Requirements

Condition	Major Prestressed Members	Minor Prestressed Members	Nonstressed Members
Forecasted atmospheric temperature $\geq 50^{\circ}\text{F}$ during specified curing period	2 concrete temperature probes per casting line to monitor high concrete temperature regions ⁵	2 concrete temperature probes per casting line to monitor high concrete temperature regions ^{1,5}	N/A
Forecasted atmospheric temperature $< 50^{\circ}\text{F}$ during specified curing period	2 concrete temperature probes per casting line to monitor high concrete temperature regions, ⁵ and 2 concrete temperature probes per casting line to monitor low concrete temperature regions ^{2,5}	2 concrete temperature probes per casting line to monitor high concrete temperature regions, ^{1,5} and 2 concrete temperature probes per casting line to monitor low concrete temperature regions ^{2,5}	1 concrete temperature probe per 100 cubic yards of concrete or fraction thereof to monitor low concrete temperature regions ²
Forecasted atmospheric temperature $< 40^{\circ}\text{F}$ during additional 3-day curing period ³	N/A	1 concrete temperature probe per similar curing condition for prestressed piling only	N/A
When accelerated curing is used	2 temperature probes per casting line to monitor curing enclosure air temperature at concrete surfaces ^{4,5}	2 temperature probes per casting line to monitor curing enclosure air temperature at concrete surfaces ^{4,5}	1 temperature probe per 100 cubic yards of concrete or fraction thereof to monitor curing enclosure air temperature at concrete surfaces

1. Excluding prestressed bridge deck panels and prestressed retaining wall panels.
2. When accelerated curing is used, concrete temperature probes to monitor low concrete temperature regions are not required.
3. After attaining specified release-of-tension strength.
4. These probes are in addition to the concrete temperature probes required for monitoring high concrete temperature regions.
5. Place probes at the beginning and end of casting line.

Attach each temperature probe to a separate temperature recording device unless multi-channel temperature recording devices are used, in which case 1 high concrete temperature probe and 1 low concrete temperature probe may be attached to the same recording device. When accelerated curing is used, 1 curing enclosure air temperature probe may also be attached to this multi-channel temperature recording device.

Inadequate curing facilities or lack of attention to the proper curing of concrete will be cause for the Engineer to stop concrete placement until approved curing is provided. Inadequate curing may be cause for rejection of the affected product.

Forms may be removed at the discretion of the Contractor at any time after the concrete has reached sufficient strength to prevent physical damage to the member. Do not interrupt curing for more than 60 min. during form removal.

The following curing requirements apply for prestressed members:

- Cure concrete continuously, except as allowed during form removal, until the compressive strength of the concrete has reached the specified release-of-tension strength and until detensioning has been performed.
- Maintain concrete temperatures between 50°F and 150°F during the curing period. The maximum allowable concrete temperature may be increased to 170°F if the Contractor uses one of the concrete mix design options listed in Section 421.4.2.6., "Mix Design Options," other than options 6, 7, and 8. The Engineer may require lowering of the total cementitious content in the concrete mix design to the limits specified in Item 421, "Hydraulic Cement Concrete," for repeated violations of the maximum curing temperature.
- Membrane curing is permitted only for unformed surfaces of prestressed wall panels and interim curing on unformed surfaces of prestressed piling. Use Type 1-D or Type 2 curing compound conforming to DMS-4650, "Hydraulic Cement Concrete Curing Materials and Evaporation Retardants," for this application.
- Water cure prestressed piling an additional 3 days after attaining the specified release-of-tension strength. Do not interrupt curing for more than 4 hr. when moving piling to the storage area. Maintain the concrete temperature of piling at 50°F or above during this additional curing period.

The following curing requirements apply for nonstressed members:

- Cure concrete continuously, except as allowed during form removal, for 4 days or until the compressive strength of the concrete has reached the design strength.
- Maintain concrete temperatures between 50°F and 150°F during the curing period. The maximum allowable concrete temperature may be increased to 170°F if the Contractor uses one of the concrete mix design options listed in Section 421.4.2.6., "Mix Design Options," other than options 6, 7, and 8.
- Membrane curing is permitted on nonstressed members, except for surfaces to be painted or color-stained.

Cure members for an additional 24 hr. beginning immediately after the normal curing period if they are out of cure at any time other than during the allowable 60 min. for form removal or during the allowable 4 hr. for moving piling to storage.

Members failing to meet the concrete temperature requirements or curing enclosure air temperature requirements during curing will be reviewed. Repeated failure to maintain proper concrete temperatures may be cause for rejection of the affected product.

4.2.7.1.

Water Curing. Water curing provides additional moisture to concrete and prevents moisture loss. Water used for curing must meet the requirements for concrete mixing and curing water specified in Section 421.2.5., "Water." Do not use seawater or water that stains or leaves an unsightly residue that cannot be removed. Monitor and maintain a temperature differential between curing water and concrete surface temperature that prevents thermal cracking.

- 4.2.7.1.1. **Wet Mat Method.** Use water-saturated cotton mats, burlap, burlap-polyethylene sheeting, or other approved moisture-retaining materials. Anchor the wet mats adequately to provide continuous contact with exposed concrete surfaces.
- 4.2.7.1.2. **Water Spray Method.** Use overlapping sprays, sprinklers, or soil-soaker hoses so concrete surfaces are kept continuously wet.
- 4.2.7.1.3. **Ponding Method.** Use an approved retarder when the air temperature is above 85°F in accordance with the manufacturer's recommendations if necessary to control concrete slump loss and lengthen the time for placing, consolidating, and finishing operations.
- 4.2.7.2. **Moisture Retention Curing.** Moisture retention curing prevents moisture loss from the concrete.
- 4.2.7.2.1. **Form Curing Method.** Concrete surfaces in direct contact with forms that are left in place will not require additional curing methods unless cold-weather protection is necessary.
- 4.2.7.2.2. **Impermeable Cover Method.** Cover exposed concrete surfaces with polyethylene sheeting, burlap-polyethylene sheeting, impervious paper, or other approved impermeable materials placed in close contact with concrete surfaces to keep them continuously wet. Provide additional moisture inside the enclosure in accordance with Section 424.4.2.7.1., "Water Curing," if this is not enough to keep exposed concrete surfaces continuously wet.

- 4.2.7.3. **Membrane Curing.** Liquid membrane-forming curing compound is a moisture retention covering that is applied as a liquid. It is only permitted as noted in Section 424.4.2.7., "Curing of Concrete."

Use Type 1-D or Type 2 membrane curing compound in accordance with DMS-4650, "Hydraulic Cement Concrete Curing Materials and Evaporation Retardants." Apply membrane curing compound with equipment and in a manner specified in Section 420.3.5., "Spraying Equipment," and Section 420.4.10.3., "Membrane Curing," respectively.

Do not contaminate reinforcing steel, embedments, or concrete surfaces that will later be in direct contact with cast-in-place concrete unless the curing compound can be completely removed to the satisfaction of the Engineer when applying membrane curing compound.

Use membrane curing compounds that do not appreciably stain the concrete.

- 4.2.7.4. **Accelerated Curing.** Accelerated curing is defined as curing with artificial heat provided to the curing enclosure or forms.

Test accelerated-curing facilities for a minimum of 48 hr. to demonstrate temperature variations do not exceed 20°F between any points in the curing enclosure. Submit accelerated curing facility drawings and test results, and obtain approval before using these facilities for Department work. The test may be performed on the entire casting line with either freshly cast concrete inside the forms or with empty forms. Provide 1 curing enclosure air temperature probe per 100 feet of casting line when accelerated curing facilities are being tested.

Maintain the air temperature in the curing enclosure between 50°F and 85°F until initial set of the concrete (as determined in accordance with Tex-440-A when establishing mix designs under representative temperature conditions) and for at least 3 hr. after concrete placement. The concrete temperature may then be raised uniformly at a maximum rate of 36°F per hour. Provide an unobstructed air space of at least 6 in. between surfaces of the concrete and the curing jacket.

Monitor and maintain the curing enclosure air temperature between 50°F and 160°F during accelerated curing for prestressed and nonstressed concrete members. Do not allow the air temperature to exceed 160°F for more than 1 cumulative hour during the entire curing period. Do not allow the air temperature to exceed 170°F at any time during the specified curing period. Arrange the location of the heat discharge into

the curing enclosure so temperature variations do not exceed 20°F between any points in the curing enclosure.

Provide curing enclosure air temperature probes to monitor the temperature at the concrete surface as specified in Table 2.

Provide enough moisture inside the curing enclosure to keep exposed concrete surfaces continuously wet for the specified curing period.

Provide other acceptable curing methods for the remaining curing period if accelerated curing is terminated before the specified curing period has elapsed.

- 4.2.7.4.1. **Steam Curing.** Steam cure in accordance with the requirements of accelerated curing. Position steam outlets so live steam is not applied directly on the concrete, forms, or test cylinders.
- 4.2.7.4.2. **Alternate Methods.** Other methods of accelerated curing, such as the use of radiant heaters or portable heater, may be permitted if they meet the requirements of accelerated curing. The use of any alternate method requires written approval.
- 4.2.8. **Detensioning.** Release the tension in the strands after concrete strength requirements are met using a sequence to minimize premature wire breakage or shock and damage to the concrete members. Release strands by multiple-strand detensioning or single-strand flame detensioning. Ensure strands are not released individually with single-strand jacks.

Flame-release each strand simultaneously at both ends of the casting bed, using a symmetrical sequence prepared by a licensed professional engineer if strands are released individually. Heat the strands over an approved strand length and duration when flame detensioning so that the metal slowly elongates and gradually loses strength. Do not abruptly flame-cut strand by holding the heat source in a concentrated location on the strand. Submit the flame-release procedures and sequences for approval. Approval of flame-release sequences does not relieve the Contractor from responsibility for meeting the product workmanship requirements of Section 424.4.3., "Workmanship."

Release the tension in the strand hold-down anchor slowly to minimize shock and damage to the concrete member when draped strands are used. Heat the anchor until the metal slowly elongates and gradually loses strength if heat is used to release the hold-down anchor. Provide positive external hold-downs to offset the vertical forces in the members when the sum of the hold-down forces is greater than half the weight of the member or for any amount of vertical force that has previously caused cracking. External hold-downs are to remain on each member until detensioning has been complete.

- 4.3. **Workmanship.** Formed surfaces must not have excessive surface honeycombing, aggregate or mortar pockets, air voids, lift lines, stains, or vibrator marks. Remove form-joint-offset marks in excess of the tolerances specified in Section 424.4.2.1.1., "External Forms," and fins and rough edges along chamfer lines, in a manner that will not damage the member. Repair fabrication holes, except box beam and U-beam drain holes, with an approved repair material and procedure.

Recess strands in accordance with the *Concrete Repair Manual* unless otherwise shown on the plans. Submit for approval any other moisture-barrier systems for protecting strands.

Before shipment of members, remove:

- concrete, paste, dirt, oil, or other bond-breaking substances from exposed reinforcing steel, and
- laitance, dirt, oil, or other bond-breaking substances from concrete surfaces to be in contact with cast-in-place concrete.

- 4.3.1. **Defects and Breakage.** Members that sustain damage or surface defects during fabrication, handling, storage, hauling, or erection are subject to review. Evaluate and repair members in accordance with the *Concrete Repair Manual*. Submit proposed deficiencies in accordance with the Department's NCR guidelines

and obtain approval before performing repairs. Repair work must reestablish the member's structural integrity, durability, and aesthetics to the satisfaction of the Engineer.

When deficiencies occur, determine the cause and take immediate corrective action. Failure to take corrective action, leading to similar repetitive deficiencies, could be cause for rejection of members.

Cracks that extend to the nearest reinforcement plane and fine surface cracks that do not extend to the nearest reinforcement plane, but are numerous or extensive, are subject to review.

Cracks in prestressed members that tend to close upon transfer of stress to the concrete are acceptable. Cracks that do not tend to close are subject to review.

Seal cracks in I-beam ends exceeding 0.005 in. in width as directed. The fabricator must decrease the spacing of Bars R and S in I-beam by providing additional bars to help limit crack width. No less than 1 in. clearance between bars will be permitted. The fabricator must take approved corrective actions if cracks greater than 0.005 in. form. All work, material, and engineering related to these cracks will be at the Contractor's expense.

Prestressed bridge deck panels will be rejected for any of the following conditions:

- any crack extending to the reinforcing plane and running parallel and within 1 in. of a strand for at least 1/3 of the embedded strand length; or
- any transverse or diagonal crack, including corner cracks and breaks, intersecting at least 2 adjacent strands and extending to the reinforcing plane.

Prestressed bridge deck panels that sustain damage, cracks not listed above, or surface defects during fabrication, handling, storage, hauling, or erection are subject to review.

4.3.2. **Tolerances.**

4.3.2.1. **Prestressed Members.** Allowable tolerances for the dimensions and configurations shown on the plans or approved shop drawings are shown in Table 3.

Variations greater than those specified in Table 3 are subject to review. However, these tolerances do not relieve the Contractor from the responsibility of furnishing a completed structure that is in reasonably close conformity with the lines, grades, cross-sections, dimensions, and details specified. Correct members not meeting these tolerances at no additional expense to the Department, to achieve a satisfactory completed structure. This also includes costs for correction due to variations in vertical beam camber. Correction may require replacement of the member.

Horizontal misalignment (sweep) in beams, which may increase at a later time and exceed the tolerance shown in Table 3, may be acceptable if the members can be hauled, erected, and aligned to within the allowable tolerance without being damaged. Store these members in a manner that will minimize the sweep.

Embedments must be firmly held in proper position to avoid movement during concrete placement. Place embedments in accordance with the manufacturer's recommendations. Place weld clip inserts for permanent metal deck forming no more than 1/16 in. from the beam edge.

Table 3
Allowable Tolerances for Prestressed Members

Dimension	I-beams	U-beams	Box and Slab Beams	Double-T Beams	Bridge Deck Panels	Piling	Wall Panels ¹
Length (perpendicular to strands for bridge deck panels)	±1"	±1"	±1"	±3/4"	±1/2"	-1" ²	±3/16"
Width (parallel to strands for bridge deck panels)	+3/4" -1/4"	±1/4"	±1/4"	±1/2"	±1/2"	±1/4"	±3/16"
Nominal depth (thickness in case of panels)	+1/2" -1/4"	±1/4"	±1/4"	±1/4"	+1/4" -1/8"	±1/4"	±3/16"
Thickness: top slab or flange	+1/2" -1/4"	±1/2"	±1/2"	±1/4"	NA	NA	NA
Thickness: bottom slab or flange	+1/2" -1/4"	±1/2"	±1/2"	NA	NA	NA	NA
Thickness: web or wall	+3/4" -1/4"	±1/2"	±1/2"	±1/4"	NA	NA	NA
Horizontal alignment (deviation from straightness of all panel edges)	±1/8" per 10' of length	±1/8" per 10' of length, 3/4" Max	±1/4"	±1/4"	±1/8"	±1/8" per 10' of length	±1/8" per 10' of length, 1/2" Max
Deviation of ends (horizontal skew)	±1/2"	±1/2"	±1/2"	±1/2"	±1/2"	±1/8"	±1/4" per 5' of width, 1/2" Max
Deviation of ends (vertical batter)	±1/2" ⁸	±1/2" ⁸	±1/2"	±1/2"	NA	±1/8"	±1/4"
Notched end areas (for diaphragms): depth	±1/4"	NA	±1/4"	±1/4"	NA	NA	NA
Notched end areas (for diaphragms): length	+2" -1"	NA	+2" -1"	+2" -1"	NA	NA	NA
Bearing surfaces: perpendicular to vertical axis	±1/8"	NA	NA	±1/16"	NA	NA	NA
Bearing surfaces: deviation from plane	±1/16"	±1/8"	±1/8"	±1/16"	NA	NA	±1/16 ³
Anchor hole location: from end of member	+3/4" -1/4"	±1/4"	±1/4"	+3/4" -1/4"	NA	NA	NA
Anchor hole location: longitudinal spacing	±3/4"	±1/2"	±1/2"	±3/4"	NA	NA	NA
Anchor hole location: transverse location	±1/4"	±1/4"	±1/4"	±1/4"	NA	NA	NA
Diaphragm or lateral tie location	±1/2"	NA	±1/2"	±1/2"	NA	NA	NA
Position of internal void form (longitudinal for box beams and U-beams)	NA	±1"	±1" ^{4,5}	NA	NA	±1/2"	NA
Projection of reinforcing steel outside of member	+1/2" -3/4"	+1/2" -3/4"	+1/2" -3/4"	+1/2" -3/4"	+1/2" -3/4"	NA	+1/2" -3/4"
Position of strands: vertical	±1/4" ⁶	±1/4"	±1/4"	±1/4"	±1/8" ⁷	±1/4"	±1/8"
Position of strands: horizontal	±1/4"	±1/4"	±1/4"	±1/4"	±1/2"	±1/4"	±1/2"
Debonded length of strands	±3"	±3"	±3"	±3"	NA	NA	NA
Position of strand hold-down points	±6"	±6"	±6"	±6"	NA	NA	NA
Position of handling devices: parallel to length	±6"	±6"	±6"	±6"	As shown on the plans	±6"	±6"
Position of handling devices: transverse to length	±1"	±1"	±1"	±1"	As shown on the plans	±1"	±1"
Local flatness of formed surfaces (excluding bearing surface)	±1/4" in 10'	±1/4" in 10'	±1/4" in 10'	±1/4" in 10'	±1/4"	±1/4" in 10'	±1/4" in 10'
Bow (length and width)	NA	NA	NA	NA	NA	NA	±1/4" per 10'

1. Prestressed and nonstressed wall panels (tie back, C-wall, sound wall, etc.) except MSE wall panels.
2. Maximum length as approved.
3. Measured along the panel depth at the top and bottom panel sides.
4. Voided box beams only.
5. Length of box beam internal void form +1 in., -6 in.
6. For draped strands, the tolerance for vertical position of strands at the end of the beam may be increased to ±1/2 in. provided the tested concrete compressive strength, before release of tension into the member, is at least 5% greater than the release-of-tension strength shown on the plans.
7. Measured from bottom of panel.
8. 3/4 in. maximum for beams exceeding a height of 54 in.

- 4.3.2.2. **Nonstressed Members.** The allowable tolerances for nonstressed members are as specified in Table 4 unless otherwise shown on the plans. The allowable tolerances for nonstressed wall panels, except MSE wall panels, are as specified in Table 3.

Table 4
Allowable Tolerances for Nonstressed Members

Member	Dimension	Tolerance
MSE wall panels and wall components ¹ (coping, posts, etc.)	All dimensions (including deviation from edge straightness)	$\pm 3/16$ in.
	Deviation of ends (horizontal skew)	$\pm 1/4$ in. in 5 ft., $\pm 1/2$ in. Max
	Local flatness of formed surfaces	$\pm 1/8$ in. in 5 ft.
	Connection hardware	$\pm 1/2$ in.

1. Includes wall components for tie-back walls, C-walls, sound walls, etc.

- 4.4. **Storage and Handling.** Mark members for identification immediately after form removal as shown on approved shop drawings in accordance with the requirements of the pertinent Items or as required. Do not change any identification markings or transfer material to other projects without approval from the Engineer. Inspect members immediately before shipping to the jobsite for damage that may have occurred in storage. Store and handle prestressed and nonstressed members in accordance with Item 425, "Precast Prestressed Concrete Structural Members."

5. MEASUREMENT AND PAYMENT

The work performed, materials furnished, equipment, labor, tools, and incidentals will not be measured or paid for directly but will be subsidiary to bid items of the Contract.

Item 425

Precast Prestressed Concrete Structural Members



1. DESCRIPTION

Furnish and erect precast prestressed concrete members fabricated by pre-tensioning, post-tensioning, or a combination of the two.

2. MATERIALS

Use materials that meet requirements of the following Items.

- Item 420, "Concrete Substructures,"
- Item 421, "Hydraulic Cement Concrete,"
- Item 426, "Post-Tensioning,"
- Item 427, "Surface Finishes for Concrete,"
- Item 434, "Bridge Bearings,"
- Item 440, "Reinforcement for Concrete,"
- Item 442, "Metal For Structures,"
- Item 445, "Galvanizing,"
- Item 448, "Structural Field Welding,"
- DMS-4650, "Hydraulic Cement Concrete Curing Materials and Evaporation Retardants," and
- DMS-7300, "Precast Concrete Fabrication Plants."

2.1. **Prestressing Hardware.** Furnish prestressing hardware that meets the manufacturer's specifications.

2.2. **Concrete.** Furnish concrete of the class shown on the plans.

2.3. **Prestressing Steel.** Furnish prestressing steel conforming to one of the following types:

- 7 wire steel strand meeting DMS 4500, "Steel Strand, Uncoated Seven-Wire Stress Relieved and Low Relaxation for Prestressed Concrete,"
- alloy bars meeting ASTM A 722, or
- steel wire meeting ASTM A 421.

Maintain copies of the manufacturer's certified Domestic Certification Form D 9 PS 1 for 7 wire steel strand and supply to the Department upon request. Use 7 wire steel strand produced by a prequalified manufacturer on the list maintained by the Construction Division. The Department may take samples in accordance with Tex 710 I to verify compliance with specification requirements.

Assign an individual lot number to all bars from each size and heat, all wire from each coil, and all strand from each reel, and tag the material for accurate identification at the jobsite. Identify each lot of anchorage assemblies and couplers in a similar manner. Unidentified prestressing steel, anchorage assemblies, or couplers received at the site will be rejected. Loss of positive identification of these items at any time will be cause for rejection.

2.4. **Post-Tensioning System.** Furnish post-tensioning system as required by Item 426, "Post-Tensioning" and as shown on the plans.

3. CONSTRUCTION.

Fabricate precast prestressed concrete members in accordance with Item 424, "Precast Concrete Structural Members (Fabrication)." Fabricate railroad structures in accordance with the latest AREMA *Manual for Railway Engineering* and Item 424, "Precast Concrete Structural Members (Fabrication)." In the case of a conflict between the AREMA manual and Item 424, "Precast Concrete Structural Members (Fabrication)," the more stringent requirements apply.

- 3.1. **Handling, Storing, Hauling, and Erection of Precast Prestressed Concrete Members.** Properly handle, store, haul, and erect all members so that they are placed in the structure in a manner to avoid excessive bending stresses and without damage. Lift members with approved lifting devices as shown on the shop drawings or as approved.

Maintain beams in an upright position at all times, and raise and support them near the ends to prevent torsion unless approved on shop or erection drawings.

Do not move members from the casting yard until all requirements of the pertinent Items have been met. Haul beams to the project site after at least 7 days have elapsed since casting unless otherwise approved.

The storage area must be clean and well drained. Prevent excessive or differential settlement of members by storing on:

- stable ground and
- dunnage of sufficient size, shape, and strength to prevent crushing.

Place dunnage a distance no more than 3% of the beam length from the beam ends. When approved, cantilever beams may be supported at locations other than near the ends. Support concrete box beams and U-beams under the solid end block area during handling, storage, hauling, and erection.

Separate members with blocking arranged in vertical planes that will not crush under load when members are stacked. Stack members so lifting devices are accessible and undamaged. Use dunnage or blocking material that will not damage or stain the required finish.

Rearrange improperly stored members and inspect them for damage. Members that are improperly stored and become cracked, warped, or otherwise damaged in storage may be rejected.

Securely tie or brace all beams during erection in accordance with minimum erection and bracing standards. Protect traffic against falling objects during the erection of diaphragms and other structural members, during the placing of cast-in-place concrete, and during the erection and dismantling of forms when railroad or roadway traffic must be maintained beneath beams already placed. Protect traffic with nets or flooring with openings not larger than 1 in. or as approved.

Fit mating surfaces to prevent excessive grout leakage when erecting precast prestressed concrete bridge deck panels. Fill the joint with grout or seal it with an acceptable caulking compound before placing the cast-in-place portion of the slab if such fit is not provided.

Finish surfaces of beams or other members after slab placement in accordance with Section 420.4.13., "Ordinary Surface Finish," and Item 427, "Surface Finishes for Concrete."

Correct beam discrepancies including, but not limited to horizontal misalignment or variations in vertical camber, to achieve a satisfactory completed structure at no additional expense to the Department. Correction may require replacement of the member.

- 3.2. **Packaging, Storing, and Handling of Prestressing Steel.** Protect prestressing steel against physical damage and rust or other results of corrosion, from manufacture to grouting or encasing in concrete. Prestressing steel with physical damage will be rejected. Replace any reel containing broken wires. Provide wire that is bright and uniformly colored, without foreign matter or pitting on the surface.

Package prestressing steel in containers or shipping forms for protection from physical damage and corrosion during shipping and storage. A corrosion inhibitor must be:

- placed in the package or form,
- incorporated in a corrosion inhibitor carrier type packaging material, or
- applied directly to the steel when permitted.

The corrosion inhibitor must not have deleterious effect on the steel, concrete, or bond strength of steel to concrete. Inhibitor carrier-type packaging material must conform to the provisions of federal specification MIL PRF 3420G. Immediately replace damaged packaging or forms, or restore them to original condition.

Have the shipping package or form clearly marked with the corrosion inhibitor type, packaging date, and a statement that the package contains high-strength prestressing steel.

Handle prestressing steel carefully to avoid abrading, nicking, or kinking the strand, bar, or wire. Protect prestressing steel from damage and corrosion by storing it above the ground on platforms, skids, or other approved supports. Any pitting or tightly adhering rust on prestressing steel will be cause for rejection of the steel. Do not weld or torch-cut near any prestressing steel, so that it is not exposed to weld spatter, direct heat, or short-circuited current flow.

When prestressing steel for post-tensioning is installed in the ducts, any rust that forms during the first 14 days after installation will not be cause for rejection of the steel.

4. MEASUREMENT

This Item will be measured by the foot, square foot, square yard, cubic yard, or each member. This is a plans quantity measurement Item. The quantity to be paid is the quantity shown in the proposal, unless modified by Article 9.2., "Plans Quantity Measurement." Additional measurement or calculations will be made if adjustments of quantities are required.

5. PAYMENT

The work performed and materials furnished in accordance with this Item and measured as provided under "Measurement" will be paid for at the unit price bid for "Prestressed Concrete" of the specified structural component and type or size. This price is full compensation for fabricating, hauling, and erection of the members; furnishing and tensioning of prestressing steel; furnishing and placing reinforcing steel and duct; furnishing and placing bearing plates, elastomeric bearings, bars, anchorage plates, and appurtenances; grouting holes; repairs; special treatment of end anchorages and shoes as required; erection bracing; and equipment, labor, tools, and incidentals.

Precast prestressed concrete bridge deck panels will not be paid for directly but will be subsidiary to pertinent Items.

Precast prestressed concrete piling will be paid for as specified in Item 409, "Prestressed Concrete Piling."

No additional compensation will be made for alternate designs or for any increase in quantities required to accommodate alternate designs, including quantities paid for under other Items.

Item 426

Post-Tensioning



1. DESCRIPTION

Furnish, store, and handle post-tensioning materials and perform post-tensioning of cast-in-place and precast structural units.

2. MATERIALS

Furnish materials that meet requirements of the most current versions of the following documents unless indicated otherwise: Post-Tensioning Institute's *Guide Specification for Grouted Post-Tensioning* (PTI/ASBI M50) and Post-Tensioning Institute's *Specification for Grouting of Post-Tensioned Structures* (PTI M55).

- 2.1. **Prestressing Steel.** Furnish prestressing steel strand conforming to one of the following types:
- Seven-wire steel strand meeting DMS-4500, "Steel Strand, Uncoated Seven-Wire Stress Relieved and Low Relaxation for Prestressed Concrete," or
 - Grade 150, high strength, coarse thread bars meeting ASTM A722.

- 2.2. **Post-Tensioning System.** Furnish a post-tensioning system following the minimum requirements for Protection Level 2 (PL-2) in accordance with PTI/ASBI M50. Prequalify post-tensioning systems using tests on complete tendons for compliance with the requirements of PTI/ASBI M50.

The following exceptions apply:

- The embedded parts of the anchorage are not required to be galvanized or epoxy coated, unless otherwise noted on the plans.
- Provide pre-packaged grouts in accordance with DMS-4670, "Grouts for Post-Tensioning" and Class C grout per PTI M55. Do not use grouts that exceed the manufacturers' recommend shelf life or 6 months, whichever is less.
- Provide unbonded single strand tendons in accordance with PTI M10.2-00: "Specification for Unbonded Single Strand Tendons."

3. EQUIPMENT

- 3.1. **Stressing Equipment.** Provide hydraulic jacks, pressure gauges, and other stressing equipment that meets PTI/ASBI M50.
- 3.2. **Grouting Equipment.** Provide grout mixing, testing, and pumping equipment that meets PTI M55.

4. CONSTRUCTION

The requirements of Item 420, "Concrete Substructures," and Item 422, "Concrete Superstructures," will govern for cast-in-place construction. Item 424, "Precast Concrete Structural Members (Fabrication)," will govern for precast concrete units or members.

- 4.1. **Qualifications of Personnel.** Perform all work for post-tensioning, including duct and hardware installation, strand insertion, and tendon or bar stressing, under the direct supervision of an individual certified as a PTI Level 2 Bonded PT Field Specialist. Perform all grouting operations under the direct supervision of an

individual who has received a Grouting Technician Certification from the American Segmental Bridge Institute (ASBI).

4.2. **Required Submittals.** Submit information required in this Section for post-tensioned elements, in addition to forming and falsework plans required by Item 420, "Concrete Substructures," and Item 424, "Precast Concrete Structural Members (Fabrication)." Include all necessary construction information in these submittals for cast-in-place and precast construction including, but not limited to the information required in this Section.

4.3. **Design Calculations.** Provide design procedures, coefficients, allowable stresses, tendon spacing, and clearances in accordance with the AASHTO LRFD *Bridge Design Specifications* and PTI/ASBI M50 unless otherwise shown on the plans. Submit sufficient calculations to support the proposed system and method of post-tensioning including friction loss diagrams. When the required jacking force for a particular type of tendon, duct, and configuration is furnished on the plans, design calculations are not required except to adjust for conditions different from those shown on the plans.

4.3.1. **Post-Tensioning Details.** Provide drawings with details that meet the requirements of PTI/ASBI M50 and this specification.

4.3.2. **Grouting Plan.** Submit for approval written grouting procedures at least 4 weeks before the start of the element's construction. Include items required by PTI M55.

Include the names of people responsible for PT installation and grouting operations, with the foreman of each grouting crew certified as a PTI Level 2 Bonded PT Field Specialist and ASBI Certified Grouting Technician.

4.4. **Packaging, Storing, and Handling of Post-Tensioning Components.** Package, store, and handle post-tensioning steel, grout, duct, and other accessories in accordance with PTI/ASBI M50 and PTI M55 unless otherwise indicated. Acceptance and rejection criteria for strand will follow PTI/ASBI M50 and PTI M55.

The following exceptions apply:

- Grout storage onsite will be limited to 30 days unless approval by the Engineer is given in advance of material delivery.
- Install grout caps and ensure vents are closed at all times so that water and other contaminants cannot enter the duct before strand installation.
- Do not flush ducts at any time.

4.5. **Duct and Prestressing Steel Installation for Post-Tensioning.** Follow PTI/ASBI M50 for duct and prestressing steel installation procedures and requirements unless otherwise specified. Verify that concrete strength requirements on the plans are met for stressing and staged loading of post-tensioned structural elements.

Stress the tendons within 7 days of installing the strand in the ducts unless otherwise approved in advance. Follow the tensioning procedure noted in the approved post-tensioning details.

4.6. **Grouting.** Grout in accordance with PTI M55.

Grout within 14 days of tendon stressing unless otherwise specified or approved. Obtain approval to extend the grouting time before stressing tendons.

Do not allow the grout temperature to exceed 85°F during mixing and pumping. Do not grout when the ambient temperature is below 35°F. Field-test the grout in accordance with Table 1 during grout installation. Perform field-testing by trained personnel at the Contractor's expense while witnessed by the Engineer. Pump at the lowest pressure possible that will maintain a continuous flow of grout.

Table 1
Requirements for Field-Testing of Grout

Test	Frequency	Requirement
Schupak Pressure Bleed Test (ASTM C1741)	1 per day	per DMS-4670
Fluidity test (Tex-437-A, Method 2)	2 every 2 hr. 2 min. per day	per DMS-4670
Compressive Strength test (3" × 6" cylinders)	1 per day	per DMS-4670
Mud Balance test (Tex-130-E Part II) ¹	2 per day	per DMS-4670

1. Take one sample from the mixer and one sample from the farthest duct outlet.

5. MEASUREMENT AND PAYMENT

The work performed, materials furnished, equipment, labor, tools, and incidentals will not be measured or paid for directly but will be subsidiary to pertinent Items.

Item 427

Surface Finishes for Concrete



1. DESCRIPTION

Finish concrete surface as specified.

2. MATERIALS

Furnish materials in accordance with this Article for the type of surface finish specified.

2.1. Coatings.

2.1.1. **Adhesive Grout and Concrete Paint.** Provide coatings in accordance with DMS-8110, "Coatings for Concrete." Match color of coating with Federal Standard 595C color 35630, concrete gray, unless otherwise shown on the plans.

2.1.2. **Opaque Sealer.** Provide penetrating-type sealer in accordance with DMS-8110, "Coatings for Concrete." Match color of coating with Federal Standard 595C color 35630, concrete gray, unless otherwise shown on the plans.

2.1.3. **Silicone-Based Paint.** Provide silicone resin emulsion paint (SREP) meeting the requirements of DMS-8141, "Paint, Silicon Resin for Concrete." Match color of coating with Federal Standard 595C color 35630, concrete gray, unless otherwise shown on the plans.

2.2. **Exposed Aggregate Finish.** Provide approved aggregates meeting the grading requirements shown on the plans. Provide gravel consisting of predominantly rounded particles unless otherwise shown on the plans. Use crushed stone when a bush-hammered finish is desired. Provide a concrete surface retardant. Provide clear Type II permanent anti-graffiti coating in accordance with DMS-8111, "Anti-Graffiti Coatings."

3. EQUIPMENT

The Engineer may require demonstration of the equipment's capabilities.

3.1. **Low-Pressure Water Blasting.** Use equipment capable of supplying a minimum pressure at the nozzle end of 3,000 psi at a minimum flow rate of 3 gpm. Use a 0° rotary, vibratory, or wobble-type nozzle. Use equipment capable of including abrasives in the water stream when specified on the plans.

3.2. **Abrasive Blasting.** Use equipment with filters to produce oil-free air and also water-free air when dry air is required.

3.3. **Slurry Blasting.** Use equipment capable of combining air and abrasives with water to form a wet blast media capable of cleaning and preparing surface without creating dust.

3.4. **Spraying.** Use equipment with fluid and air pressure regulators and gauges to allow for adjustment to produce a uniform spray pattern for spray applications.

3.5. **Off-the-Form Finish Forms.** Use nonstaining, nonporous, high-quality forming materials (e.g., steel or medium-density and high-density overlaid plywood forms). Use steel or high-density overlaid plywood forms when the same form will be used more than twice.

- 3.6. **Form Liners.** Provide form liners capable of producing a patterned finish as shown on the plans. Use form liners that provide a clean release from the concrete surface without pulling or breaking the textured concrete.

4. CONSTRUCTION

Provide the finish specified on the plans for the specific surface areas.

- 4.1. **Surface Areas of Finish.** "Surface area of finish" designates the areas where the specified surface is to be applied.

4.1.1. **Surface Area I.**

- surfaces of railing;
- exterior vertical faces of fascia beams, slabs, slab spans, arches, and box girders;
- the outside bottom surface of fascia beams and girders;
- the underside of overhanging slabs to the point of juncture of the supporting beam;
- the entire underside of slab spans when shown on the plans;
- vertical and underside surfaces of bents and piers;
- all surfaces of tie beams, abutments, bridge wingwalls, culvert headwalls and wingwalls, and retaining walls exposed to view after all backfill and embankment is placed; and
- all other exposed surfaces shown on the plans to require surface treatment.

- 4.1.2. **Surface Area II.** Surfaces of railing, all wingwalls, and the exterior vertical faces of slabs.

- 4.1.3. **Surface Area III.** Only the top and roadway faces of all concrete railing and bridge wingwalls.

- 4.1.4. **Surface Area IV.** Areas designated on the plans.

- 4.2. **Coatings.** Apply the coating specified on the plans.

- 4.2.1. **Preparation.** Clean the surface thoroughly before applying a coating by chemical cleaning, if required, and by blast cleaning.

Submit a containment plan that details the procedures proposed to keep public property, private property, and the environment from being adversely affected by the cleaning and painting operations. Do not discharge washwater into body of water or conveyance without TCEQ approval. Collect and properly dispose of any paint or debris dislodged as a result of cleaning operations.

- 4.2.1.1. **Chemical Cleaning.** Clean surfaces contaminated with oil, grease, or other contaminants by scrubbing the area with an approved detergent or other concrete cleaning material before blast cleaning. Do not use a solvent that will stain the surface or inhibit coating adhesion. Perform the following test to check for surface contamination of oil type materials:

- Spray the surface with a fine mist of potable water.
- Examine the area to see if water beads up.
- Clean the surface if beading is found.

- 4.2.1.2. **Blast Cleaning.** Blast clean the designated surface to remove weak surface material, curing compound, and other contaminants before applying a specified coating, leaving a lightly etched uniformly textured surface. Use an approved abrasive propelled by oil-free air with or without the addition of potable water, or blast with potable water with or without the addition of an approved abrasive at sufficient pressure to effectively clean and prepare the surface. Maintain the stand-off-distance of the nozzle to a maximum of 12 in. from the surface being cleaned when water blasting.

Do not damage concrete surface by gouging, spalling, or exposing coarse aggregate by the blasting operation.

Blow clean oil- and moisture-free air on all surfaces with sufficient pressure to remove loose particles immediately before application of any coating. Perform the following test to check for surface cleanliness as directed:

- Press a 10 in. long strip of 2 in. wide clear packing tape on the surface by rubbing with moderate pressure.
- Grasp the free end of the tape, and remove the tape from the surface with a sharp jerk.
- Examine the surface of the tape for clinging particles.

Continue cleaning the concrete surface until there are no particles clinging to the tape surface for subsequent tests. An additional test that can be used to check the surface for dust is to wipe the surface with a dark cloth and then examine the cloth for discoloration.

- 4.2.2. **Application.** Mix coating materials thoroughly with a mechanical mixer at a speed that causes the mixture to rotate entirely in the container. Ensure complete mixing by probing the container with a stirring device searching for non-dispersed or settled material.

Apply coatings once the new concrete has aged a minimum of 28 days except for the adhesive grout coating. Do not apply coatings when weather conditions will be detrimental to the final surface finish as determined by the Engineer. Do not apply coatings when surface temperature of the concrete exceeds 110°F.

Apply coatings to obtain a consistent color and texture.

- 4.2.2.1. **Adhesive Grout.** Apply coating on a moistened surface to a uniform minimum thickness of 1/16 in. Apply when ambient temperature is at least 50°F.
- 4.2.2.2. **Concrete Paint.** Apply the coating on a dry surface in 2 coats for a total maximum application rate of 150 sq. ft. per gallon. Match the color of the applied coating with the color standard shown on the plans. Do not thin material unless approved. Apply when ambient temperature is between 50°F and 100°F.
- 4.2.2.3. **Opaque Sealer.** Apply the coating to a dry surface in 2 coats for a total maximum application rate of 200 sq. ft. per gallon. Match the color of the applied coating with the approved color standard shown on the plans. Do not thin the material unless approved. Apply when ambient temperature is between 40°F and 100°F.
- 4.2.2.4. **Silicone Resin Paint.** Apply the coating on a dry surface in 2 coats at a rate not exceeding 300 sq. ft. per gallon per coat. Do not thin the material unless approved. Wait a minimum of 12 hr. between coats. Apply when ambient temperature is between 50°F and 100°F.

Repair surface finish where coating has been applied that exhibits peeling, flaking, or discoloration or has been damaged during construction. Remove defective or damaged coating. Clean and recoat repair area in accordance with the requirements of this Item.

- 4.3. **Special Surface Finishes.** Submit a work plan to the Engineer for any special finish shown on the plans. Include in the work plan the type of aggregates, materials, variation of panel or pattern arrangement, dimensions, construction methods, and other features affecting the work as is necessary for the "Special Surface Finish" specified.

- 4.3.1. **Blast Finish.** Provide surface profile as shown on the plans, or meet the minimum requirements of Section 427.4.2.1., "Preparation." Construct a 4 × 4 ft. sample panel using the same concrete used in construction of the member to receive the blast finish. Prepare the surface of the sample panel to meet the specified finish, and obtain approval of the sample finish. Use the approved sample panel finish as the standard for surfaces requiring a blast finish.

- 4.3.2. **Slurry Coat Finish.** Provide cementitious slurry coat finish to concrete surfaces within 14 days of placing concrete or later as approved. Water blast surface to moisten surface before application when application of slurry coat occurs more than 14 days after placing concrete. Do not apply slurry coat finish to surfaces receiving another type coating finish.

Submit for approval proposed slurry recipe including cement, latex concrete additive, with or without sand, and other additives before application. The Engineer will direct the level of surface texture the slurry coat will have, whether to include sand, and what fineness of sand is to be used. Tint mixture of slurry as specified on the plans and as directed. Maintain consistent slurry throughout project only modifying recipe to account for color variations being noticed as work progresses.

Rub in slurry with carborundum stone, stiff bristle brush, or other approved device. Limit thickness of applied slurry to a maximum of 1/16 in. thick. Demonstrate application methods for slurry coat and obtain approval of proposed surface. Apply slurry coat to obtain a tightly adhering cementitious finish to concrete surface. Remove material and reapply if slurry coat is not tightly adhering or is cracked.

- 4.3.3. **Rub Finish.** Provide a finish to the surface by rubbing the surface with a carborundum stone or other approved material. Begin rubbing the surface immediately after forms have been removed. Provide blast finish or other finish as directed at no additional cost to the Department if rubbing surface is delayed to the point where the surface is dry and unable to be rubbed to produce an acceptable finish. Perform the requirements to obtain the ordinary surface finish specified in Section 420.4.13., "Ordinary Surface Finish," concurrently with rubbing the surface. Rub concrete-patching areas after the patch material has thoroughly set and blend the patch in with the surrounding area to produce a surface with uniform color and texture where concrete patching is performed.

Keep the surface continuously wet after form removal until the rubbing is complete. Rub the surface sufficiently to bring the wetted concrete surface to a paste producing a smooth dense surface without pits, form marks, or other irregularities. Do not use cement grout to form the paste on the surface. Stripe the surface with a brush to conceal the rubbing pattern and allow the paste to reset. Wash the concrete with potable water after the paste has sufficiently set to leave it with a neat and uniform appearance and texture. Apply membrane curing, if required, in accordance with Item 420, "Concrete Substructures," after rubbing is complete.

- 4.3.4. **Off-the-Form Finish.** Provide a finish with minimal surface defects and uniform color and texture by using non-staining, non-porous, high-quality forming materials. Use the same type of forming materials for like elements for the entire structure.

Use mortar-tight forms to prevent leakage and discoloration. Seal joints with compressible gasket material, caulk, tape, or by other suitable means that are not detrimental to the concrete finish if necessary. Use one brand and type of form-release agents for all surfaces unless another product produces a similar concrete surface appearance. Do not use barrier-type (wax, fuel oil, carrier oil, etc.) release agents. Use form-release agents containing a rust inhibitor on steel forms. Clean rust off steel forms before use. Use plywood that will not cause discoloration of the concrete surface.

Direct special attention to consolidation and vibration of the concrete around the form surfaces to minimize bug holes. Modify concrete placement and vibration techniques if surface contains an excessive amount of bug holes. Remove all forms without interruption once form removal begins to prevent discoloration due to differing form curing times.

Do not use membrane curing on surfaces with off-the-form finish.

Repair honeycombed and spall areas with least dimension larger than 2 in. in accordance with the concrete surface repair procedures outlined in Item 420, "Concrete Substructures," to obtain an ordinary surface finish as defined in Section 420.4.13., "Ordinary Surface Finish." Patch honeycombed and spall areas with least dimension greater than 3/4 in. but smaller than 2 in. by filling defect with repair material omitting the chipping operation. Do not patch honeycombed and spall areas with least dimension smaller than 3/4 in. Perform required repairs as soon as forms are removed. Match repair material color and texture with surrounding

concrete surfaces. Minimize the area of repair by not smearing the repair material over acceptable concrete surfaces in an attempt to blend the repair with the surrounding concrete. Cut out form ties at least 1/2 in. below the surface, and patch accordingly. Perform repair work as soon as possible after removing forms so that concrete and repair material have similar ages. Replace or refurbish the forms when the Engineer determines defective formwork is causing an excessive amount of repair work.

- 4.3.5. **Form Liner Finish.** Provide patterned finish as shown on the plans. Do not splice form liner panels in a way that causes a noticeable transition or line between pieces. Wash and clean form liners after each use when the forms can be reused. Replace form liners that have become damaged or worn.

Construct a sample panel for each form liner finish. Approval is required to verify the sample panel meets the requirements of the plans and specifications before beginning work. Upon approval, the sample panel becomes the model panel that all other work will be compared against. Deviation in color, grade, or depth from the model panel is grounds for rejection of the form liner finish. Removal of defective work may be necessary as determined by the Engineer and in accordance with the surface finish requirements outlined in Item 420, "Concrete Substructures," to obtain an ordinary surface finish as defined in Section 420.4.13., "Ordinary Surface Finish."

Seal all form liner joints in a manner acceptable to the Engineer to prevent leakage at the surface.

- 4.3.6. **Exposed Aggregate Finish.** Provide exposed aggregate finish as indicated on the plans. Provide a depth of finish between 3/8 in. and 1/2 in. unless directed otherwise.

Apply a concrete surface retarder that penetrates approximately 1/4 in. into the forms or concrete surface to help achieve the desired finish. Apply 2 or 3 coats to wood forms to account for absorption if necessary. Tape or caulk form joints to prevent escape of the retarder during the placing operations. Protect the form surfaces from sun and rain while exposed to the atmosphere. Re-treat form surfaces with retarder if disturbed. Protect adjacent areas of concrete not requiring exposed aggregate finish from the retarder.

Remove forms 12 to 15 hr. after concrete placement but not before concrete has gained sufficient strength to support the self-weight of the member unless directed otherwise. Expose the aggregate for the finish immediately after form removal. Remove the grout paste covering the aggregate to be exposed by an approved method. Do not loosen the aggregate by the grout removal operation. Maintain required curing on all surfaces except for the time while the aggregate is being exposed. Cure using wet mats or membrane after the aggregate is exposed.

Repair defective areas as determined by the Engineer.

Re-clean exposed aggregate surfaces by an approved method. Apply a coat of clear Type II permanent anti-graffiti coating to cleaned exposed aggregate surface. Apply anti-graffiti coatings by spray, roller, or brush at the application rates recommended by the manufacturer and in accordance with Item 740, "Graffiti Removal and Anti-Graffiti Coating."

5. MEASUREMENT

When surface finishes for concrete is shown on the plans to be a pay item, measurement will be by the square foot of the type of surface finish specified.

This is a plans quantity measurement item. The quantity to be paid is the quantity shown in the proposal, unless modified by Article 9.2., "Plans Quantity Measurement." Additional measurement or calculations will be made if adjustments of quantities are required.

6. PAYMENT

Unless otherwise specified on the plans, the work performed, materials furnished, equipment, labor, tools, and incidentals will not be paid for directly but will be considered subsidiary to pertinent items.

When a surface finish for concrete is specified as a pay item, the work performed and materials furnished in accordance with this Item and measured as provided under "Measurement" will be paid for at the unit price bid for "Adhesive Grout Finish," "Concrete Paint Finish," "Opaque Sealer Finish," "Silicone Resin Paint Finish," or "Blast Finish." This price is full compensation for materials; cleaning and preparing surfaces; application of materials; and equipment, labor, tools, and incidentals.

Slurry coat, rub, off-the-form, form liner, or exposed aggregate finishes (including anti-graffiti coating) will not be paid for under this Item but are subsidiary to other pertinent Items.

Item 428

Penetrating Concrete Surface Treatment



1. DESCRIPTION

Prepare surface and apply a penetrating sealant treatment to concrete surfaces.

2. MATERIALS

Provide penetrating surface treatment in accordance with DMS-8140, "Concrete Surface Treatment (Penetrating)."

3. CONSTRUCTION METHODS

Apply surface treatment to locations shown on the plans. Treat the upper surfaces of the roadway slab (including direct traffic culverts), bridge sidewalks and medians, the inside faces of curbs, and concrete rails for bridge decks. Do not treat surfaces given a higher finish as defined in Item 427, "Surface Finishes for Concrete," unless otherwise shown on the plans.

Refer to the manufacturer's specifications for instruction on the use of the treatment material in addition to the requirements of this Item.

Clean the concrete surfaces using shot or abrasive blasting, unless otherwise restricted, followed by vacuuming and air blasting as needed, to remove all visible curing compound, oils, and any other contaminants that retard or prevent penetration of the mixture before treatment application. Additionally, roughen vertical and overhead steel formed surfaces that are smooth in appearance by abrasive blasting or other approved method. Completely remove all spent abrasive media. Demonstrate the method of cleaning to the Engineer before proceeding.

Do not damage the concrete surface to the point the coarse aggregate is exposed. Apply the treatment material after the entire cleaned surface has been accepted by the Engineer.

Apply the treatment material no sooner than 28 days after casting the concrete.

Delay the treatment to concrete riding surfaces requiring mechanical grinding or grooving until approved to proceed.

Apply treatment material to a dry surface no sooner than 24 hr. after any water has reached the concrete surface. Apply treatment material when surface temperature is between 40°F and 100°F.

Do not dilute or alter the treatment material.

Apply the treatment material at a rate of 100 sq. ft. of surface area per gallon. Treat the upper side of horizontal and near-horizontal surfaces in 1 pass or coat. Treat the vertical and overhead surfaces in 2 passes or coats. Apply the first coat to fully saturate the surface and until refusal. Allow the first coat to be absorbed, but do not allow the surface to completely dry before applying the second coat. Wait no longer than 1 hr. for application of the second coat.

Use a spray applicator equipped with a spray bar to apply the treatment material to deck surfaces.

Apply the treatment material at a uniform rate, covering the entire surface being treated.

Follow the treatment material manufacturer's specifications regarding required lapse time before traffic is permitted on the treated surface.

4. MEASUREMENT

This Item will be measured by the square yard of concrete surface treated. This is a plans quantity measurement Item. The quantity to be paid is the quantity shown in the proposal, unless modified by Article 9.2., "Plans Quantity Measurement." Additional measurements or calculations will be made if adjustments of quantities are required.

5. PAYMENT

The work performed and materials furnished in accordance with this Item and measured as provided under "Measurement" will be paid for at the unit price for "Penetrating Concrete Surface Treatment." This price is full compensation for furnishing materials and for equipment, labor, tools, and incidentals.

Item 429

Concrete Structure Repair



1. DESCRIPTION

Remove and repair unsound, delaminated, or spalled concrete.

2. MATERIALS

Submit all proposed repair materials for approval. Provide materials as outlined in the *Concrete Repair Manual* and in accordance with the requirements of the following Items.

- Item 421, "Hydraulic Cement Concrete,"
- Item 431, "Pneumatically Placed Concrete,"
- Item 440, "Reinforcement for Concrete,"
- DMS-4655, "Concrete Repair Materials," and
- DMS-6100, "Epoxyes and Adhesives."

- 2.1. **Concrete Repair Materials.** Provide repair materials suitable for the appropriate horizontal, vertical, or overhead application meeting the requirements in DMS-4655, "Concrete Repair Materials." Use Type C trowel-applied materials in vertical and overhead applications less than 3" unless otherwise shown on the plans. Use neat Type A (Rapid) or Type D (Standard) materials in horizontal or form-and-pour applications less than 3" thick and extended Type A or Type D for repairs exceeding 3" in depth. Type D repairs should be used in lieu of Type A when rapid strength gain is not necessary. Use Type B ultra-rapid hardening materials only if shown on the plans. The Engineer may disallow any product based on its structural compatibility.
- 2.2. **Pneumatically Applied Materials.** Pneumatically applied concrete or mortar may be used, if approved, for any repair thickness. Provide and place pneumatically applied concrete in accordance with Item 431, "Pneumatically Placed Concrete." Prepare trial batches of any proposed repair material and application method as directed.
- 2.3. **Epoxy Mortars.** Use Type VIII neat epoxy or epoxy mortar per DMS-6100, "Epoxyes and Adhesives," for repairs less than 1 in. thick unless noted otherwise on the plans.
- 2.4. **Concrete.** Provide Class C concrete for substructures, Class S concrete for decks, or concrete of the specified design strength unless noted otherwise as follows:
 - as an option for vertical/overhead repairs greater than 6 in. thick;
 - for full or partial depth slab repairs;
 - for replacement of entire members or elements;
 - as an option for horizontal repairs greater than 4 in. thick.

Submit a mix design for approval in accordance with Item 421, "Hydraulic Cement Concrete," unless otherwise shown on the plans. Include all pertinent information on admixtures. Do not use corrosion-inhibiting admixtures unless indicated on the plans or approved.
- 2.5. **Steel.** Provide steel pins, studs, or expansion bolts with a minimum diameter of 1/8 in. and a minimum length of 2 in. to attach reinforcement at the locations shown on the plans or as directed. Provide reinforcing steel, either welded wire fabric or reinforcing bars, as required by this Item or as shown on the plans.

3. CONSTRUCTION METHODS

Follow the procedures outlined in the *Concrete Repair Manual* unless approved otherwise. The Contractor may propose alternate repair methods for review and approval before commencing work.

Submit for approval all materials and methods of application at least 3 weeks before beginning any repair work.

Repair locations will be indicated on the plans or by the Engineer.

- 3.1. **Crack Repair.** Repair cracks in accordance with Item 780, "Concrete Crack Repair."
- 3.2. **Repair of Defective Work.** Repair or replace defective areas and patched areas that have debonded after completion of curing, as directed, at the Contractor's expense.

4. MEASUREMENT

This Item will be measured by the square foot, in place, as measured on the specified horizontal, vertical, or overhead surfaces of the completed repair as shown below or by the cubic yard for full element or member replacement. When a repair involves multiple surfaces, such as a corner, measurement will be made of all surfaces repaired. Bridge deck repairs will be measured by the square foot in place of the completed repair.

5. PAYMENT

The work performed and materials furnished in accordance with this Item and measured as provided under "Measurement" will be paid for at the unit price bid for "Concrete Structure Repair" of the kind specified. This price is full compensation for furnishing, placing, and curing all repair materials; removing concrete; saw-cutting; cleaning reinforcing steel; supplying and installing replacement or supplemental reinforcing steel, drive pins, studs, or expansion bolts; and equipment, labor, and incidentals.

Item 431

Pneumatically Placed Concrete



1. DESCRIPTION

Furnish and place pneumatically applied concrete for the construction of portions of structures, repairing concrete structures, encasement of structural steel members, lining ditches and tunnels, soil-nail walls, retaining walls, and other work as shown on the plans or as directed.

2. MATERIALS

Provide pre-bagged concrete materials for concrete structure repair and class of concrete shown on the plans for other work unless otherwise shown on the plans.

Submit pre-bagged materials information for approval. Material testing may be required before approval and installation test panels will be required in accordance with Section 431.2.4., "Proportioning and Mixing."

Provide materials in accordance with the pertinent requirements of the following Items with the exceptions noted in Section 431.2.1., "Exceptions to Item 421, 'Hydraulic Cement Concrete,'" Section 431.2.2., "Exceptions to Item 440, 'Reinforcement for Concrete,'" and Section 431.2.3., "Exception to DMS-6310, 'Joint Sealants and Fillers.'"

- Item 420, "Concrete Substructures"
- Item 421, "Hydraulic Cement Concrete"
- Item 440, "Reinforcement for Concrete"
- DMS-4655, "Concrete Repair Materials"
- DMS-6310, "Joint Sealants and Fillers"

- 2.1. **Exceptions to Item 421, "Hydraulic Cement Concrete."** Provide a fine aggregate that meets the requirements of Item 421, "Hydraulic Cement Concrete," Table 6, Grade 1, and a coarse aggregate that meets the requirements of Item 421, "Hydraulic Cement Concrete," Table 4, Grade 7, unless otherwise noted on the plans.
- 2.2. **Exceptions to Item 440, "Reinforcement for Concrete."** Provide mushroom headed steel anchors or expansion anchor hook bolts with a minimum diameter of 1/8 in. and a minimum length of 2 in. to attach reinforcement for the repair of concrete structures as shown on the plans or as directed. Reinforcing steel may be either welded wire fabric or reinforcing bars unless otherwise shown on the plans.
- 2.3. **Exception to DMS-6310, "Joint Sealants and Fillers."** Provide a preformed bituminous fiber material unless otherwise noted on the plans.
- 2.4. **Proportioning and Mixing.** Submit for approval a proposed mix design conforming to the basic mix design requirements provided in Table 1 unless otherwise shown on the plans.

Table 1
Classes of Concrete

Class	Ratio of Cement to Total Aggregate ¹	Minimum 7-Day Compressive Strength (psi) ²
I	1:4	3,000
II	1:5	2,500

1. More cement may be used when approved.
2. Higher minimum strengths may be specified.

Measure the cement and aggregates by volume and mix with enough water to achieve the desired consistency. Use as little water as possible to achieve sufficient adhesion. Mix concrete sufficiently dry so it will not sag or fall from vertical or inclined surfaces or separate in horizontal work.

Prepare test panels using the same air pressure, nozzle tip, and position to be used for the production work to verify the mix design before approval. Apply a 3-in. layer of concrete to a plywood sheet with minimum dimensions of 18 in. × 18 in. for each test panel. Cure the test panels in the same manner as the proposed work.

Take 3 cores, each 2 in. in diameter, out of each test panel and test in compression at 7 days in accordance with Tex-424-A. The mix design will be approved when the average strength of the 3 cores conforms to the strengths shown in Table 1. Provide additional test panels as directed if there are any changes in materials, equipment, or nozzle operator during the work.

3. CONSTRUCTION

- 3.1. **Qualification.** Provide experienced personnel able to produce concrete satisfying plan requirements and of uniform quality as required. Provide documentation of nozzle operator's qualification for the process proposed and orientation of the application meeting the minimum requirements when shown on the plans.

Demonstrate nozzle operator's abilities by constructing test panels before commencement of work. Orient test panels to match application direction of placement. Include reinforcing steel in the test panel with similar spacing as in member. Qualification test panels may be used for mix verification in accordance with Section 431.2.4., "Proportioning and Mixing."

- 3.2. **Surface Preparation.** Grade the area of proposed work accurately to the elevation and dimensions shown on the plans when concrete is to be placed against soil. Compact with sufficient moisture to provide a firm foundation and to prevent absorption of water from the concrete but without free surface moisture.

Remove paint, rust, loose mill scale, grease or oil, and all other foreign materials that may reduce the bond of the concrete to the steel when concrete is used to encase structural steel members.

Remove all deteriorated or loose material by chipping with pneumatic, electric, or hand tools when concrete is placed against concrete or rock. Cut square or slightly undercut shoulders approximately 1 in. deep along the perimeter of repair areas. Sandblast the surface to clean all rust from exposed reinforcing steel and to produce a clean rough-textured surface on the concrete or rock. Wet the surface against which the concrete will be placed for at least 1 hour with potable water. Place the concrete when the surface has dried to a saturated surface-dry (SSD) condition. Achieve SSD conditions by high-pressure water blasting 15 to 30 min. before placing the repair material, soaking a minimum of 12 hr., or by other approved methods. An SSD condition is achieved when the surface remains damp when exposed to sunlight for 15 min.

Provide joints, side forms, headers, and shooting strips for backing or paneling. Use ground or gauging wires where necessary to establish thickness, surface planes, and finish lines.

- 3.3. **Reinforcement.** Place and secure reinforcement to ensure there is no displacement from impact of applying pneumatically placed concrete. Place reinforcing bars at a spacing not less than 2-1/2 in. Support reinforcing wire fabric or bars using mushroom headed anchors, expansion hook bolts, or grouted rebar capable of resisting a pullout force of 2,500 lb. Space anchors no more than 12 in. center-to-center on overhead

surfaces, 18 in. center-to-center on vertical surfaces, and 36 in. center-to-center on top horizontal surfaces. Use at least 3 anchors in each individual patch area. Do not use explosive force to shoot anchors into concrete. Check the resistance to pullout of the reinforcing anchors when directed. Notify the Engineer before installation of the anchors. Locate anchors so there is no damage to prestressing tendons or conduits embedded in the concrete.

Use reinforcement when performing repair work in all areas where the thickness of the concrete will exceed 1-1/2 in. Use a single layer of either 2 × 2 – W1.2 × W1.2 or 3 × 3 – W1.5 × W1.5 of welded wire fabric, or approved equivalent, unless noted otherwise on the plans. Use a single layer of wire fabric to reinforce each 4 in. thickness of patch or fractional part in areas where the concrete thickness exceeds 4 in. Encase completely each layer of wire fabric in concrete that has taken its initial set before installing the succeeding layer of wire fabric. Place the reinforcing fabric parallel to the finished surface, and support it so it will be at least 3/4 in. out from the surface to be covered. Provide at least 1 in. clearance between the finished concrete surface and all steel items including anchors, reinforcing bars, and wire fabric. Lap adjacent fabric sheets at least 6 in. and tie together securely at a spacing of no more than 18 in. Pre-bend fabric before installing to fit around corners and into re-entrant angles.

Pre-bend the welded wire fabric for encasement of steel members using a template to conform as nearly as possible to the outlines of the members to be encased. Drill holes between 1/2 and 1 in. in diameter in the webs of the members as close as possible to the flanges to allow for attachment of the reinforcing fabric. Space these holes at approximately 3 ft. on center. Use 3/8-in. diameter rods placed through these holes to secure the reinforcing fabric. Hold the reinforcing fabric at least 3/4 in. out from the surface of the steel member. Lap adjacent fabric sheets at least 6 in. and tie together at a spacing of no more than 12 in.

- 3.4. **Pneumatic Placement of Concrete.** Pneumatically applied concrete can be either dry-mix or wet-mix. The dry-mix process consists of dry-mixed fine aggregate and hydraulic cement to which water is added immediately before its pneumatic expulsion from a nozzle. The wet-mix process consists of mechanically premixed concrete pneumatically applied through a nozzle.

- 3.4.1. **General.** Place the concrete when the ambient temperature is above 35°F and rising and material temperature is between 50°F and 90°F for wet-mix and below 100°F for dry-mix. Do not place concrete against a surface containing frost, ice, or standing water. Protect concrete from freezing or quick drying after placement. Apply the concrete using pneumatic equipment that sprays the mix onto the prepared surface at a velocity less than 100 ft. per second for construction of portions of structures, repairing concrete structures, or encasement of structural steel members. Minimize rebound and produce a compacted dense homogenous mass. Do not apply concrete if high winds will prevent proper application or if rain could wash out the concrete.

Hold the nozzle approximately 2 to 4 ft. from the surface and position it so the concrete impinges nearly at right angles to the surface being covered. Use shooting strips to ensure straight lines, square corners, and a plane surface of concrete. Place to keep the trapping of rebound to a minimum. Slope the concrete off to a thin edge at the end of each day's work or at similar stopping periods requiring construction joint. Thoroughly clean and wet previously placed concrete before placing an adjacent or additional section. Apply a sufficient number of coats to obtain the required thickness. Place coats on vertical and overhead surfaces in layers of such thickness to prevent sloughing, sagging, tearing, or debonding. Provide a sufficient interval between successive layers in sloping, vertical, or overhead work to allow initial but not final set. Clean the surface to remove the thin film of laitance to provide for a bond with succeeding applications. Remove rebound and accumulated loose sand from the surface to be covered before placing of the original or succeeding layers of concrete. Correct any sags or other defects to the proper section as directed.

Place concrete to completely encase reinforcing steel. Encase reinforcing steel by shooting with sufficient velocity and plasticity that material flows around and behind reinforcement.

Apply the concrete using either the wet-mix or dry-mix process unless otherwise noted on the plans. Mix the materials thoroughly and uniformly using a paddle or drum type mixer designed for pneumatic application. Wet-mix process applications can use transit-mix concrete. Do not use the wet-mix process for repair of damaged concrete.

Clean mixing and placing equipment at regular intervals. Inspect the nozzle liner and water and air injection system daily; replace worn parts as necessary.

Do not reuse rebound or overspray concrete.

- 3.4.2. **Dry-Mix Process.** Use a compressor or blower capable of delivering a sufficient volume of oil-free air at the pressure shown in Table 2. Maintain steady pressure throughout the placing process.

Use a water pump with the size and capacity to deliver water to the nozzle with a pressure at least 15 psi more than the required air pressure.

The values shown in Table 2 are based on a hose length of 150 ft. with the nozzle less than 25 ft. above the delivery equipment. Increase operating pressure approximately 5 psi for each additional 50 ft. of hose and approximately 5 psi for each 25 ft. the nozzle is raised.

Table 2
Compressor Capacities

Compressor Capacity, CFM	Hose Diameter, in.	Maximum Size of Nozzle Tip, in.	Operating Air Pressure Available, psi
250	1	3/4	40
315	1-1/4	1	45
365	1-1/2	1-1/4	55
500	1-5/8	1-1/2	65
600	1-3/4	1-5/8	75
750	2	1-3/4	85

- 3.4.3. **Wet-Mix Process.** Operate the pump at a line pressure between 100 psi and 300 psi. Use delivery hoses between 1-1/2 in. and 3 in. in diameter. Use mixing equipment capable of thoroughly mixing the materials in sufficient quantity to maintain continuous placement.
- 3.5. **Construction Joints.** Use a square butt joint where the joint is subject to compressive stress or is over existing construction joints unless noted otherwise on the plans. Use tapered or square butt joints at other locations. Square the outside 1 in. of tapered joints perpendicular to the surface.
- 3.6. **Finish.** Use a sharp trowel to cut off all high spots after the concrete has been placed to the desired thickness or screed to a true plane as determined by shooting strips or by the original concrete surface. Lightly apply cutting screeds, where used, to all surfaces so as not to disturb the concrete for an appreciable depth. Work in an upward direction when concrete is applied on vertical surfaces. Give the finished concrete a final flash coat of about 1/8 in. unless directed otherwise. Obtain a uniform appearance on all exposed surfaces unless otherwise shown on the plans.
- 3.7. **Curing.** Cure encasements with water for 4 days. Cure repairs and structural construction using either a piece of wet burlap taped over the repaired area with a covering of 4-mil minimum plastic sheet also taped in place or membrane curing as approved. Overlap the burlap with the plastic sheet and continuously tape the edges with a tape at least 3 in. wide (air duct tape or better) to completely enclose the mat and hold in moisture. Cure in this manner for 4 days. Curing is not required for soil-nail walls unless walls are the final exposed surfaces, which in this case, cure at least 4 days in accordance with Item 420, "Concrete Substructures." Apply membrane curing in accordance with Section 420.2.7., "Curing Materials," for tunnel and ditch linings and vertical or overhead patches as approved.
- 3.8. **Repair of Defects.** Repair or replace debonded areas as directed.

4. MEASUREMENT

Measurement of pneumatically placed concrete for encasement of structural members will be by the square foot of the actual contact area.

Measurement of pneumatically placed concrete for repair of concrete structures will be by the cubic foot in place using the surface area times the average depth of the patch. When pneumatically placed concrete for repair of concrete structures is allowed or specified for Item 429, "Concrete Structure Repair," measurement and payment is in accordance with Article 429.5., "Payment."

5. PAYMENT

When pneumatically placed concrete is specified as a bid item, the work performed and materials furnished in accordance with this Item and measured as provided under "Measurement" will be paid for at the unit price bid for "Pneumatically Placed Concrete (Encasement)" or for "Pneumatically Placed Concrete (Repair)." This price is full compensation for cement, aggregate, water, and reinforcement; furnishing and installing steel anchors; removal of deteriorated or unsound concrete; mixing, placing, and curing pneumatically placed concrete; and equipment, labor, tools, and incidentals. Pneumatically placed concrete used for work other than encasement or repair will not be paid for directly but will be considered subsidiary to pertinent Items.

Item 432

Riprap



1. DESCRIPTION

Furnish and place concrete, stone, cement-stabilized, or special riprap.

2. MATERIALS

Furnish materials in accordance with the following Items.

- Item 420, "Concrete Substructures,"
- Item 421, "Hydraulic Cement Concrete,"
- Item 431, "Pneumatically Placed Concrete,"
- Item 440, "Reinforcement for Concrete," and
- DMS-6200, "Filter Fabric."

2.1. **Concrete Riprap.** Use Class B Concrete unless otherwise shown on the plans.

2.2. **Pneumatically Placed Concrete Riprap.** Use Class II concrete that meets Item 431, "Pneumatically Placed Concrete," unless otherwise shown on the plans.

2.3. **Stone Riprap.** Use durable natural stone with a bulk specific gravity of at least 2.50 as determined by Tex-403-A unless otherwise shown on the plans. Provide stone that, when tested in accordance with Tex-411-A, has weight loss of no more than 18% after 5 cycles of magnesium sulfate solution.

Perform a size verification test on the first 5,000 sq. yd. of finished riprap stone for all types of stone riprap at a location determined by the Engineer. Test the riprap stone in accordance with ASTM D5519. Additional tests may be required. Do not place additional riprap until the initial 5,000 sq. yd. of riprap has been approved.

Provide grout or mortar in accordance with Item 421, "Hydraulic Cement Concrete," when specified. Provide grout with a consistency that will flow into and fill all voids.

Provide filter fabric in accordance with DMS-6200, "Filter Fabric." Provide Type 2 filter fabric for protection stone riprap unless otherwise shown on the plans. Provide Type 2 filter fabric for Type R, F, or Common stone riprap when shown on the plans.

2.3.1. **Type R.** Use stones between 50 and 250 lb. with at least 50% of the stones heavier than 100 lb.

2.3.2. **Type F.** Use stones between 50 and 250 lb. with at least 40% of the stones heavier than 100 lb. Use stones with at least 1 broad flat surface.

2.3.3. **Common.** Use stones between 50 and 250 lb. Use stones that are at least 3 in. in their least dimension. Use stones that are at least twice as wide as they are thick. When shown on the plans or approved, material may consist of broken concrete removed under the Contract or from other approved sources. Cut exposed reinforcement flush with all surfaces before placement of each piece of broken concrete.

2.3.4. **Protection.** Use boulders or quarried rock that meets the gradation requirements of Table 1. Both the width and the thickness of each piece of riprap must be at least 1/3 of the length. When shown on the plans or as approved, material may consist of broken concrete removed under the Contract or from other approved sources. Cut exposed reinforcement flush with all surfaces before placement of each piece of broken

concrete. Determine gradation of the finished, in-place, riprap stone under the direct supervision of the Engineer in accordance with ASTM D5519.

Table 1
In-Place Protection Riprap Gradation Requirements

Size	Maximum Size (lb.)	90% Size ¹ (lb.)	50% Size ² (lb.)	8% Size ³ Minimum (lb.)
12 in.	200	80–180	30–75	3
15 in.	320	170–300	60–165	20
18 in.	530	290–475	105–220	22
21 in.	800	460–720	175–300	25
24 in.	1,000	550–850	200–325	30
30 in.	2,600	1,150–2,250	400–900	40

1. Defined as that size such that 10% of the total riprap stone, by weight, is larger and 90% is smaller.
2. Defined as that size such that 50% of the total riprap stone, by weight, is larger and 50% is smaller.
3. Defined as that size such that 92% of the total riprap stone, by weight, is larger and 8% is smaller.

The Engineer may require in-place verification of the stone size. Determine the in-place size of the riprap stone by taking linear transects along the riprap and measuring the intermediate axis of the stone at select intervals. Place a tape measure along the riprap and determine the intermediate axis size of the stone at 2 ft intervals. Measure a minimum of 100 stones, either in a single transect or in multiple transects, then follow ASTM D5519 Test Procedure Part B to determine the gradation. Table 2 is a guide for comparing the stone size in inches to the stone weight shown in Table 1.

Table 2
Protection Riprap Stone Size¹

Size	Dmax (in.)	D90 (in.)	D50 (in.)	D8 (in.)
12 in.	13.76	10.14–13.29	7.31–9.92	3.39
15 in.	16.10	13.04–15.75	9.21–12.91	6.39
18 in.	19.04	15.58–18.36	11.10–14.21	6.59
21 in.	21.85	18.17–21.09	13.16–15.75	6.88
24 in.	23.53	19.28–22.29	13.76–16.18	7.31
30 in.	32.36	24.65–30.84	17.34–22.72	8.05

1. Based on a Specific Gravity of 2.5 and using the following equation for the intermediate axis diameter $D = \{(12 \cdot W) / (Gs \cdot 62.4 \cdot 0.85)\}^{1/3}$

where:

D = intermediate axis diameter in in.;

W = weight of stone in lbs.;

Gs = Specific Gravity of stone.

Note—If the Specific Gravity of the stone is different than 2.5, then the above equation can be used to determine the appropriate size using the actual Specific Gravity.

If required, provide bedding stone that, in-place, meets the gradation requirements shown in Table 3 or as otherwise shown on the plans. Determine the size distribution in Table 3 in accordance with ASTM D6913.

Table 3
Protection Riprap Bedding Material Gradation Requirements

Sieve Size (Sq. Mesh)	% by Weight Passing
3"	100
1-1/2"	50–80
3/4"	20–60
#4	0–15
#10	0–5

2.4. **Cement-Stabilized Riprap.** Provide aggregate that meets Item 247, "Flexible Base," for the type and grade shown on the plans. Use cement-stabilized riprap with 7% hydraulic cement by dry weight of the aggregate.

2.5. **Special Riprap.** Furnish materials for special riprap according to the plans.

3. CONSTRUCTION

Dress slopes and protected areas to the line and grade shown on the plans before the placement of riprap. Place riprap and toe walls according to details and dimensions shown on the plans or as directed.

- 3.1. **Concrete Riprap.** Reinforce concrete riprap with 6 × 6 – W2.9 × W2.9 welded wire fabric or with No. 3 or No. 4 reinforcing bars spaced at a maximum of 18 in. in each direction unless otherwise shown. Alternative styles of welded wire fabric that provide at least 0.058 sq. in. of steel per foot in both directions may be used if approved. A combination of welded wire fabric and reinforcing bars may be provided when both are permitted. Provide a minimum 6-in. lap at all splices. Provide horizontal cover of at least 1 in. and no more than 3 in. at the edge of the riprap. Place the first parallel bar no more than 6 in. from the edge of concrete. Use approved supports to hold the reinforcement approximately equidistant from the top and bottom surface of the slab. Adjust reinforcement during concrete placement to maintain correct position.

Sprinkle or sprinkle and consolidate the subgrade before the concrete is placed as directed. All surfaces must be moist when concrete is placed.

Compact and shape the concrete once it has been placed to conform to the dimensions shown on the plans. Finish the surface with a wood float after it has set sufficiently to avoid slumping to secure a smooth surface or broom finish as approved.

Cure the riprap immediately after the finishing operation according to Item 420, "Concrete Substructures."

- 3.2. **Stone Riprap.** Provide the following types of stone riprap when shown on the plans:

- **Dry Riprap.** Stone riprap with voids filled with only spalls or small stones.
- **Grouted Riprap.** Type R, F, or Common stone riprap with voids grouted after all the stones are in place.
- **Mortared Riprap.** Type F stone riprap laid and mortared as each stone is placed.

Use spalls and small stones lighter than 25 lb. to fill open joints and voids in stone riprap, and place to a tight fit.

Place mortar or grout only when the air temperature is above 35°F. Protect work from rapid drying for at least 3 days after placement.

Place filter fabric with the length running up and down the slope unless otherwise approved. Ensure fabric has a minimum overlap of 2 ft. Secure fabric with nails or pins. Use nails at least 2 in. long with washers or U-shaped pins with legs at least 9 in. long. Space nails or pins at a maximum of 10 ft. in each direction and 5 ft. along the seams. Alternative anchorage and spacing may be used when approved.

- 3.2.1. **Type R.** Construct riprap as shown in Figure 1 on the *Stone Riprap Standard* and as shown on the plans. Place stones in a single layer with close joints so most of their weight is carried by the earth and not the adjacent stones. Place the upright axis of the stones at an angle of approximately 90° to the embankment slope. Place each course from the bottom of the embankment upward with the larger stones in the lower courses.

Fill open joints between stones with spalls. Place stones to create a uniform finished top surface. Do not exceed a 6-in. variation between the tops of adjacent stones. Replace, embed deeper, or chip away stones that project more than the allowable amount above the finished surface.

Prevent earth, sand, or foreign material from filling the spaces between the stones when the plans require Type R stone riprap to be grouted. Wet the stones thoroughly after they are in place, fill the spaces between the stones with grout, and pack. Sweep the surface of the riprap with a stiff broom after grouting.

3.2.2. Type F.

3.2.2.1. **Dry Placement.** Construct riprap as shown in Figure 2 on the *Stone Riprap Standard*. Set the flat surface on a prepared horizontal earth bed, and overlap the underlying course to secure a lapped surface. Place the large stones first, roughly arranged in close contact. Fill the spaces between the large stones with suitably sized stones placed to leave the surface evenly stepped and conforming to the contour required. Place stone to drain water down the face of the slope.

3.2.2.2. **Grouting.** Construct riprap as shown in Figure 3 on the *Stone Riprap Standard*. Size, shape, and lay large flat-surfaced stones to produce an even surface with minimal voids. Place stones with the flat surface facing upward parallel to the slope. Place the largest stones near the base of the slope. Fill spaces between the larger stones with stones of suitable size, leaving the surface smooth, tight, and conforming to the contour required. Place the stones to create a plane surface with a variation no more than 6 in. in 10 ft. from true plane. Provide the same degree of accuracy for warped and curved surfaces. Prevent earth, sand, or foreign material from filling the spaces between the stones. Wet the stones thoroughly after they are in place, fill the spaces between them with grout, and pack. Sweep the surface with a stiff broom after grouting.

3.2.2.3. **Mortaring.** Construct riprap as shown in Figure 2 on the *Stone Riprap Standard*. Lap courses as described for dry placement. Wet the stones thoroughly before placing mortar. Bed the larger stones in fresh mortar as they are being placed and shove adjacent stones into contact with one another. Spread excess mortar forced out during placement of the stones uniformly over them to fill all voids completely. Point up all joints roughly either with flush joints or shallow, smooth-raked joints as directed.

3.2.3. **Common.** Construct riprap as shown in Figure 4 on the *Stone Riprap Standard*. Place stones on a bed excavated for the base course. Bed the base course of stone well into the ground with the edges in contact. Bed and place each succeeding course in even contact with the preceding course. Use spalls and small stones to fill any open joints and voids in the riprap. Ensure the finished surface presents an even, tight surface, true to the line and grades of the typical sections.

Prevent earth, sand, or foreign material from filling the spaces between the stones when the plans require grouting common stone riprap. Wet the stones thoroughly after they are in place; fill the spaces between them with grout; and pack. Sweep the surface with a stiff broom after grouting.

3.2.4. **Protection.** Construct riprap as shown in Figure 5 on the *Stone Riprap Standard*. Place riprap stone on the slopes within the limits shown on the plans. Place stone for riprap on the filter fabric to produce a reasonably well-graded mass of riprap with the minimum practicable percentage of voids. Construct the riprap to the lines and grades shown on the plans or staked in the field. A tolerance of +6 in. and -0 in. from the slope line and grades shown on the plans is allowed in the finished surface of the riprap. Place riprap to its full thickness in a single operation. Avoid displacing the filter fabric. Ensure the entire mass of stones in their final position is free from objectionable pockets of small stones and clusters of larger stones. Do not place riprap in layers, and do not place it by dumping it into chutes, dumping it from the top of the slope, pushing it from the top of the slope, or any method likely to cause segregation of the various sizes. Obtain the desired distribution of the various sizes of stones throughout the mass by selective loading of material at the quarry or other source or by other methods of placement that will produce the specified results. Rearrange individual stones by mechanical equipment or by hand if necessary to obtain a reasonably well-graded distribution of stone sizes. Use the bedding thickness shown and place stone for riprap on the bedding material to produce a reasonably well-graded mass of riprap with the minimum practicable percentage of voids if required on the plans.

3.3. **Pneumatically Placed Concrete Riprap, Class II.** Meet Item 431, "Pneumatically Placed Concrete." Provide reinforcement following the details on the plans and Item 440, "Reinforcement for Concrete." Support reinforcement with approved supports throughout placement of concrete.

Give the surface a wood-float finish or a gun finish as directed. Cure the riprap with membrane-curing compound immediately after the finishing operation in accordance with Item 420, "Concrete Substructures."

- 3.4. **Cement-Stabilized Riprap.** Follow the requirements of the plans and the provisions for concrete riprap except when reinforcement is not required. The Engineer will approve the design and mixing of the cement-stabilized riprap.
- 3.5. **Special Riprap.** Construct special riprap according to the plans.

4. MEASUREMENT

This Item will be measured by the cubic yard of material complete in place. Volume will be computed on the basis of the measured area in place and the thickness and toe wall width shown on the plans.

If required on the plans, the pay quantity of the bedding material for stone riprap for protection to be paid for will be measured by the cubic yard as computed from the measured area in place and the bedding thickness shown on the plans.

5. PAYMENT

The work performed and materials furnished in accordance with this Item and measured as provided under "Measurement" will be paid for at the unit price bid for "Riprap" of the type, thickness, and void-filling technique (Dry, Grout, Mortar) specified, as applicable. This price is full compensation for furnishing, hauling, and placing riprap and for filter fabric, expansion joint material, concrete and reinforcing steel, grout and mortar, scales, test weights, equipment, labor, tools, and incidentals.

Payment for excavation of toe wall trenches, for all necessary excavation below natural ground or bottom of excavated channel, and for shaping of slopes for riprap will be included in the unit price bid per cubic yard of riprap.

When bedding is required for protection stone riprap, payment will be made at the unit price for "Bedding Material" of the thickness specified. This price is full compensation for furnishing, hauling, placing, and maintaining the bedding material until placement of the riprap cover is completed and accepted; excavation required for placement of bedding material; and equipment, scales, test weights, labor, tools, and incidentals. No payment will be made for excess thickness of bedding nor for material required to replace embankment material lost by rain wash, wind erosion, or otherwise.

Item 434

Bridge Bearings



1. DESCRIPTION

Furnish and install bearings for the support of bridge superstructure and substructure members. Bridge bearings under this specification consist of the 2 following categories and subcategories:

1.1. Elastomeric Bridge Bearings:

- **Plain Elastomeric Bearings.** Consisting of elastomer only.
- **Laminated Elastomeric Bearings.** Consisting of alternating individual layers of elastomer and steel laminates, with or without a steel top plate and special components (steel guide bars and bottom plate).
- **Sliding Elastomeric Bearings.** Consisting of a steel top (sole) plate with a stainless steel facing (upper component) bearing on a lower component. The lower component consists of a layer of polytetrafluoroethylene (PTFE) recessed and bonded to a steel plate that is vulcanized to the top of a laminated elastomeric bearing pad with or without special components (steel guide bars and bottom plate).

Plain and laminated elastomeric bridge bearings are designated by hardness (durometer), size, and configuration and, in the case of laminated bearings, by the thickness of the individual layers of elastomer and the size and position of any steel top plates.

1.2. High Load Multi-Rotational (HLMR) Bearings:

- **Disc Bearings.** Consisting of a polyether urethane disc contained between upper and lower steel bearing plates. The bearing has a shear resisting mechanism to prevent relative horizontal movement of the bearing plates and transmit horizontal loads.
- **Pot Bearings.** Consisting of a plain elastomeric disc confined by a shallow steel cylinder (pot) and a steel piston which engages the cylinder sufficiently to prevent their relative horizontal movement.

Provision for sliding movements (if required) uses a separate steel top plate with stainless steel facing (upper component) bearing on a lower component, and a lower component with a layer of PTFE bonded to the top of the upper steel bearing plate of the HLMR assembly. If required on the plans, restriction of lateral movement is provided by guide bars integrated with the steel top plate and interface components of the same stainless steel facing and PTFE layer.

HLMR bridge bearings are designated by configuration (fixed, multi-direction expansion, or guided expansion) and the vertical service reaction requirements. Fixed configurations allow rotation about the horizontal axis and prevent horizontal movement in all directions. Multi-direction expansion configurations allow rotation about the horizontal axis and horizontal movement in all directions. Guided expansion configurations allow rotation about the horizontal axis and horizontal movement in one direction as indicated on the plans, while guide bars and keyways restrict horizontal movement in the orthogonal direction. Provide either disc bearings or pot bearings unless a disc or pot bearing is specifically required on the plans. Provide a fabricator-designed HLMR bearing meeting the performance and dimensional criteria described on the plans and Section 434.2.3., "HLMR Bearings."

Bearings consisting of hinged steel bolster and rocker shoes, steel flat, cylindrical, or spherical bearings, and single/multiple steel roller bearings are not covered by this Item and must conform to Item 442, "Metal for Structures," unless shown otherwise on the plans.

2. MATERIALS

2.1. **Plain and Laminated Elastomeric Bearings.** Furnish bearings produced by a manufacturer from elastomer formulations approved by the Department. The Department's MPL has a list of approved bridge bearing elastomer formulations.

2.1.1. **Elastomer.** Provide elastomer for bearings formulated from previously unvulcanized 100% virgin polychloroprene rubber polymers meeting the physical properties, heat resistance, and compression set requirements of AASHTO M 251, Table X1.1, unless otherwise shown on the plans. Do not provide bearings containing previously vulcanized synthetic rubber or other synthetic rubber-like polymers. Perform material tests on the finished product in accordance with the applicable test methods. Do not use standard laboratory test slabs for this purpose. Prepare test specimens from the finished product in accordance with ASTM D3183.

Obtain approval for each elastomer formulation before use on Department projects. Submit certified test results to the Construction Division to prequalify and obtain approval of a particular formulation. Show actual test values obtained and the required values for the physical properties, heat resistance, and compression set of the elastomer when tested for compliance with the minimum requirements of AASHTO M 251, Table X1.1.

Forward samples (freight prepaid) to the Construction Division, Materials and Pavements Section, or their contracted testing laboratory when directed.

Submit only elastomer of the type or types to be supplied. Submit prequalification samples consisting of 2 finished bearings typical of the formulation and workmanship for Department projects. Submit 2 samples of each type when laminated and plain bearings are required. Laminated sample bearings may represent both plain bearings and laminated bearings for an elastomer formulation.

Plain sample bearings must measure 9 in. × 19 in. × 1 in. Laminated sample bearings must measure 9 in. × 14 in. × 1-1/2 in. with the following number of steel laminates:

- 50 durometer—3 steel laminates,
- 60 durometer—2 steel laminates, and
- 70 durometer—2 steel laminates.

Adhesion testing of laminated prequalification samples will be performed by the Department in accordance with Tex-601-J, Part I—Adhesion Test Method 1. Bond failure between the elastomer and steel laminates must occur as stated in this test method to constitute a passing test result. Presence of chlorinated compounds (neoprene) in the elastomer will be verified by the Department in accordance with Tex-601-J, Part IV—Chlorinated Compound Test Method.

Costs associated with testing elastomer formulations failing to conform to the requirements of this Item are borne by the bearings manufacturer. This cost will be assessed at the rate established by Construction Division at the time of testing.

Certify that the submitted samples are of the same basic elastomer formulation and of equivalent cure as the finished products to be furnished on Department projects.

Complete prequalification testing will be performed for each formulation at least once every 2 yr. and when necessary.

2.1.2. **Steel Laminates.** Provide steel laminates, for laminated bearings, of commercial grade steel strip or sheet with a thickness of 0.105 ±0.015 in.

2.1.3. **Steel Top Plates.** Provide steel top plates, when required for laminated bearings, in accordance with the plans.

2.1.4. **Special Components.** Provide steel guide bars and bottom plates, when required for laminated bearings, in accordance with the plans.

2.1.5. **Coatings.** Provide protective coatings for steel components materials in accordance with Item 445, "Galvanizing," or DMS-8104, "Paint, Shop Application for Steel Bridge Members," unless indicated otherwise on the plans.

2.2. Sliding Elastomeric Bearings.

2.2.1. Lower Component.

2.2.1.1. **PTFE.** Furnish PTFE materials that are pure virgin polytetrafluoroethylene fluorocarbon resin, unfilled. The finished materials must exhibit the physical properties shown in Table 1.

2.2.1.2. **Laminated Elastomeric Bearing Pad and Steel Plate.** Furnish laminated elastomeric bearing pads in accordance with Sections 434.2.1., "Plain and Laminated Elastomeric Bearings," and 434.3.1., "Plain and Laminated Elastomeric Bearings." Provide steel plates attached to laminated elastomeric bearing pads in accordance with the plans.

Table 1
Required PTFE Physical Properties

Physical Property	Test Method	Value (Unfilled)
Tensile strength, psi	ASTM D4894	2,800 Min
Elongation, %	ASTM D4894	200 Min
Melting point	ASTM D4894	622 ±4°F
Specific gravity	ASTM D792	2.16 ±0.03

2.2.2. Upper Component.

2.2.2.1. **Steel Top (Sole) Plates.** Provide steel top (sole) plates in accordance with the plans, and finished to ANSI #500 or better on the surface interfacing with the stainless steel sheet.

2.2.2.2. **Stainless Steel.** Provide Type 304 stainless steel sheet in accordance with ASTM A240. The thickness must be at least 1/16 in. unless otherwise shown on the plans.

2.2.3. **Special Components.** Provide steel guide bars and bottom plates, when required for sliding elastomeric bearings, in accordance with the plans.

2.2.4. **Coatings.** Provide coating materials as required in accordance with Item 445, "Galvanizing," and DMS-8104, "Paint, Shop Application for Structural Steel," unless indicated otherwise on the plans.

2.3. HLMR Bearings.

2.3.1. **Structural Design.** Provide a fabricator-developed design for the HLMR (disc or pot) bearings, meeting the service and factored vertical load capacity, service and factored horizontal load capacity, rotational capacity, and translation capacity requirements indicated on the plans and augmented by the requirements of this Item. Provide a bearing capable of transmitting 15% of the service vertical force as a factored horizontal load if no horizontal load capacity is provided on the plans. Provide a design that uses sole plate geometry or a grout interface to accommodate the longitudinal and transverse aspects of the bridge grade, and does not require the bearing to accommodate this in rotation unless indicated otherwise on the plans. If the bridge element supported by the bearing is cambered for dead load to be applied after the bearing is positioned, the dead load design rotation of the elastomer may be neglected provided the fabricator-developed design has checked the bearing for this temporary condition to ensure no damage occurs and there is no metal-to-metal contact. Provide a design that meets the current versions of the AASHTO LRFD *Bridge Design Specifications* and AASHTO LRFD *Bridge Construction Specifications*. Assume the plan rotations do not include requirements for uncertainties and construction tolerance stipulated in the AASHTO Specifications unless indicated on the plans.

- 2.3.2. **Maintenance Functionality.** Provide a fabricator-developed design that allows future removal with a maximum vertical jacking height of 1/4 in. after the load is removed. Provide a design with minimum 4-in. distance between the bottom of masonry plate and top of sole plate.
- 2.3.3. **Elements of HLMR Bearings.**
- 2.3.3.1. **Lower Component.**
- 2.3.3.1.1. **Polyether Urethane for Disc Bearings.** Furnish polyether urethane discs conforming to the material requirements of the AASHTO LRFD *Bridge Design Specifications* and AASHTO LRFD *Bridge Construction Specifications*, and the load and rotation demand indicated in Section 434.2.3.1., "Structural Design."
- 2.3.3.1.2. **Elastomeric Rotational Element for Pot Bearings.** Provide elastomer conforming to the material requirements of the AASHTO LRFD *Bridge Design Specifications* and AASHTO LRFD *Bridge Construction Specifications*, and the load and rotation demand indicated in Section 434.2.3.1., "Structural Design," with the exception that usage of virgin natural polyisoprene (natural rubber) is not allowed.
- 2.3.3.1.3. **PTFE.** For expansion HLMR bearings, furnish PTFE materials that are pure virgin polytetrafluoroethylene fluorocarbon resin, unfilled. The finished materials must exhibit the physical properties shown in Table 1. Provide PTFE that is bonded to the top steel bearing plate of the HLMR assembly in accordance with AASHTO LRFD *Bridge Construction Specifications*.
- 2.3.3.2. **Upper Component.**
- 2.3.3.2.1. **Steel Top Plates.** Provide steel top plates in accordance with the AASHTO LRFD *Bridge Design Specifications* and AASHTO LRFD *Bridge Construction Specifications*. Provide an ANSI #500 or better finish on the surface interfacing with the stainless steel sheet for expansion bearings. At the fabricator's option, the steel top plate may serve the function of the sole plate between the supported structure and the HLMR bearing assembly provided it matches geometric bevel requirements, plan dimensions, and minimum thickness for the sole plate depicted on the plans, while maintaining the performance requirements and avoiding damage due to installation. Otherwise, provide connectivity between the top plate and the sole plate or grouted interface as indicated on the plans. Coordinate any necessary adjustments to the sole plate geometry, connection method, or grouted interface with the Engineer to ensure compatibility with the structural design, before ordering any materials. Provide bolted connections for connection to steel trapezoidal box girder superstructures.
- 2.3.3.2.2. **Stainless Steel.** Provide Type 304 stainless steel sheet in accordance with ASTM A240. The thickness must be at least 1/16 in. unless otherwise shown on the plans.
- 2.3.3.3. **Miscellaneous Components.**
- 2.3.3.3.1. **Lateral Guides.** Provide guide bars integrated with the steel top plate and interface components of stainless steel facing and PTFE for guided HLMR expansion bearings. Submit alternate interface components to stainless steel and PTFE for review and approval. Provide details indicating guide bar, stainless steel, and PTFE attachment and design to sustain the lateral loads specified on the plans while maintaining unimpeded expansion capability.
- 2.3.3.3.2. **Piston.** Provide in accordance with the AASHTO LRFD *Bridge Design Specifications* and AASHTO LRFD *Bridge Construction Specifications*.
- 2.3.3.3.3. **Pot.** Provide in accordance with the AASHTO LRFD *Bridge Design Specifications* and AASHTO LRFD *Bridge Construction Specifications*.
- 2.3.3.3.4. **Sealing Rings.** Provide in accordance with the AASHTO LRFD *Bridge Design Specifications* and AASHTO LRFD *Bridge Construction Specifications*.

- 2.3.3.3.5. **Sealants.** Provide in accordance with the AASHTO LRFD *Bridge Design Specifications* and AASHTO LRFD *Bridge Construction Specifications*.
- 2.3.3.4. **Supporting Masonry Plate and Anchor Rods.** Coordinate any necessary adjustments to masonry plate geometry, connection method, or grout interface with the Engineer to ensure compatibility with the structure design before ordering any materials. Provide medium strength, mild steel or better type anchor rods in accordance with Item 449, "Anchor Bolts," including nuts and washers, unless indicated otherwise on the plans.
- 2.3.3.5. **Coatings.** Provide coating materials as required in accordance with Item 445, "Galvanizing," or DMS-8104, "Paint, Shop Application for Steel Bridge Members," unless indicated otherwise on the plans. Submit fabricator-preferred alternative coatings to the Engineer for review and approval.

3. CONSTRUCTION

- 3.1. **Plain and Laminated Elastomeric Bearings.** Electronically submit shop drawings for the complete assembly before fabrication of laminated elastomeric bearings with or without steel top plates or special components in accordance with the plans and Item 441, "Steel Structures." Provide a bearing layout with the shop drawings.

Mold together components of a laminated bearing to form an integral unit free of voids or separations in the elastomer or between the elastomer and the steel laminates or plates, unless otherwise shown on the plans. Provide well-vulcanized elastomer between the laminates or plates and on the outer surfaces of the bearing that is uniform and integral and resists separation by mechanical means into separate, definite, well-defined elastomeric layers. Evidence of this layered construction, either at the outer surfaces or within the bearing, will be cause for rejection. Repair of damaged elastomer on sides of laminated bearings is not allowed for product acceptance. Repair of damaged elastomer on top or bottom surfaces of laminated bearings is allowed when approved.

Cover edges of steel laminates with 1/8 in. to 1/4 in. of elastomer except exposure of the laminates will be permitted at approved laminate restraining devices and around holes entirely enclosed in the finished structure. Position laminates within 1/8 in. of plan location.

Plain bearings may be molded individually, cut from previously molded strips or slabs molded to the full thickness of the finished bearings, or extruded and cut to length. The finish of cut surfaces must be ANSI 250, or smoother. The finished bearings must have no voids or separations detectable either at the bearing surfaces or within the bearing. Plain elastomeric bearings must be well vulcanized, uniform, and integral units of such construction that the bearing is incapable of being separated by any mechanical means into separate, definite, well-defined elastomeric layers. Evidence of layered construction either at the outer surfaces or within the bearing will be cause for rejection.

The permissible variation from the dimensions and configuration shown on the plans for both plain and laminated bearings will be as listed in AASHTO M 251, Table 2. Flash tolerance, finish, and appearance must meet the requirements of the latest edition of the *Rubber Handbook* published by the Rubber Manufacturers Association, Inc., RMA F3 and T.063 for molded bearings and RMA F2 for extruded bearings.

Perform required welding in accordance with Item 441, "Steel Structures." Manufacture guide bars, when required, so adjacent top and bottom bar surfaces are parallel to within 1/16 in. in the assembled position. The tolerance for diameter of anchor bolt holes is +1/8 in., -0. The maximum deviation for flatness of steel plates is 1/16 in. in any 24 in. or as shown on the plans.

- 3.1.1. **Markings.** Mark the bearing type on the surface of each bearing as shown on the plans. The marking must remain legible until placement in the structure. Permanently mark, in addition, laminated bearings with:
- manufacturer's name or trademark,
 - lot number,
 - date of manufacture (month-year), and

- direction of slope.

Place this permanent marking on a face which is visible after erection of the bridge unless otherwise shown on the plans.

- 3.1.2. **Testing and Acceptance.** The sampling and testing of laminated bearing production, after prequalification approval, will be as follows:
- 3.1.2.1. **Laminated Bearings.** Subject each laminated bearing to a compression of 2,250 psi or a stress approved by the Engineer. Provide calibrated equipment per ASTM E4 for this compression testing. Each bearing will be acceptable if there is no visible evidence of bond failure or other damage and if the finished bearing meets other pertinent portions of this Item. Samples may be taken if the quality of production becomes questionable.
- 3.1.3. **Documentation.** Furnish certified laboratory test results on the elastomer properties of each batch or lot of compound for both plain and laminated bearings. Provide copies of certified mill test reports for laminated bearing steel top plates and any required steel special components.
- 3.1.4. **Storage.** Protect plain and laminated bearings from sunlight until placement in the structure.
- 3.1.5. **Field Methods.** Provide concrete surfaces for bearing areas under plain and laminated elastomeric bearings in accordance with Section 420.4.9., "Treatment and Finishing of Horizontal Surfaces."

Do not damage the elastomer when welding near bearings.

Damaged bearings will be subject to rejection and require replacement as directed.

- 3.2. **Sliding Elastomeric Bearings.** Electronically submit shop drawings for the complete assembly before fabrication of sliding elastomeric bearings in accordance with the plans and Item 441, "Steel Structures." Provide a bearing layout with the shop drawings.

Finish the steel top (sole) plate surface, interfacing with the stainless steel sheet, per Section 434.2.2.2.1., "Steel Top (Sole) Plates." Provide this finished surface flat to a tolerance of 1/32 in. Provide the remaining surface, outside the stainless steel sheet interface, flat to a tolerance of 1/16 in. in any 24 in.

Attach the stainless steel sheet to the steel top (sole) plate by continuous fillet-welding around the edges with an approved welding electrode. Do not extend the weld above the sliding surface. Protect the sliding surface from weld spatter. Polish the stainless steel sheet to a bright mirror finish less than 20 micro-in. rms, and solvent-clean to remove traces of polishing compound after attachment to the steel plate.

Fabricate the laminated elastomeric bearing pads according to Section 434.3.1., "Plain and Laminated Elastomeric Bearings." Vulcanize the laminated elastomeric bearing pad to the PTFE-faced steel plate. Machine the steel plate recessed surface flat to a tolerance of 1/32 in. and within 1/32 in. of required depth. Bond the PTFE material to the steel plate recessed surface with an approved adhesive. Fit the PTFE material into the recessed surface with not more than 1/32-in. gaps around the perimeter.

Perform required welding in accordance with Item 441, "Steel Structures." Manufacture guide bars when required so that adjacent top and bottom bar surfaces are parallel to within 1/16 in. in the assembled position. The tolerance for diameter of anchor bolt holes is +1/8 in., -0 in.

- 3.2.1. **Markings.** Mark the bearing type on the surface of each sliding elastomeric bearing. The marking must remain legible until placement in the structure. Permanently mark the laminated elastomeric bearing pad with the information specified in Section 434.3.1.1., "Markings."
- 3.2.2. **Testing and Acceptance.** Test a minimum of 10% of the sliding elastomeric bearing assemblies to a compressive strength of 2,250 psi or a stress approved by the Engineer. Provide calibrated equipment per

ASTM E4 for this compression testing. No tested sliding elastomeric bearing may show visible damage to the PTFE or stainless steel surfaces nor evidence of bond failure between the:

- PTFE-faced steel plate and laminated elastomeric bearing pad,
- steel laminates and elastomer within the laminated elastomeric bearing pad, and
- steel plate and PTFE.

Perform check tests if necessary on the steel, laminated elastomeric bearing pads, or PTFE material to verify the properties required under Section 434.2.2., "Sliding Elastomeric Bearings."

Bearings represented by test specimens passing the requirements of this Item will be approved for use in the structure subject to on-site inspection by the Engineer for visible defects.

- 3.2.2.1. **Lower Component.** Manufacture 1 additional bearing lower component per project for testing purposes. Notify the Construction Division, which will sample a bearing lower component at random from the lot, after bearings have been manufactured for a project. Forward selected samples (freight prepaid) to the Construction Division, or to their contracted testing laboratory when directed. Lower component samples will be tested to the following:
- Tex-601-J, Part II—Adhesion Test Method 2. Adhesion between the PTFE material and steel plate must meet a minimum 20 lb. per inch.
 - Tex-601-J, Part III—Adhesion Test Method 3. Bond failure between the PTFE-faced steel plate and the laminated elastomeric bearing pad must occur as stated in this test method to constitute a passing test result.

Costs associated with testing sliding elastomeric bearing lower component project samples failing to conform to these requirements are borne by the bearings manufacturer. This cost will be assessed at the rate established by Construction Division at the time of testing.

- 3.2.2.2. **Documentation.** Furnish copies of certified mill test reports for the steel top (sole) plate, stainless steel, PTFE-faced steel plate, and any required steel special components. Provide a manufacturer's certification that the PTFE material meets the requirements of this Item. Furnish certified laboratory test results on the elastomer properties of each batch or lot of compound for laminated elastomeric bearing pads.

- 3.2.3. **Storage.** Store sliding elastomeric bearings horizontally in a dry, sheltered area. Provide moisture and dust-resistant wrapping maintained in good condition until installation. Lift bearings only from the undersides. Protect bearings from damage, dirt, oil, grease, and other foreign substances.

- 3.2.4. **Field Methods.** Provide concrete surfaces for bearing areas under sliding elastomeric bearings in accordance with Section 420.4.9., "Treatment and Finishing of Horizontal Surfaces."

Refer to the plans for temperature setting corrections for all bridges and bearing alignment relative to a chord for curved bridges. Perform such adjustments as directed if the plans do not address these requirements.

Exercise care in any field-welding required for the installation of a sliding elastomeric bearing to prevent damage to the elastomer, PTFE, or stainless steel surface. Repair damage to protective coating on the bearings and apply the final appearance coat in accordance with Item 446, "Field Cleaning and Painting Steel."

Damaged bearings will be subject to rejection and require replacement as directed.

- 3.3. **HLMR Bearings.** Electronically submit shop drawings for the complete assembly, before fabrication of HLMR bearings, in accordance with the plans. Provide a bearing layout with the shop drawings including geometric placement on substructure. Provide design calculations sealed by a licensed professional engineer.

- 3.3.1. **Markings.** Provide a permanent identification mark indicating each bearing's position in the structure and a direction arrow oriented in the forward station direction. Ensure the primary identification mark or a second such mark is provided at a visible location on the bearing after superstructure construction.
- 3.3.2. **Testing and Acceptance.** Coordinate arrangements for sampling and testing with the Construction Division before manufacturing all or a significant number of bearings for the project. Coordinate with the Construction Division, the number and type of tests that must be observed by a designated Construction Division representative. Perform testing in accordance with Section 18, "Bearing Devices," of the current AASHTO LRFD *Bridge Construction Specifications*. Use prequalification for certain tests only if approved by the Construction Division.
- Disassemble bearings for visual inspection after testing. Replace or repair any bearings that reveal malfunction such as lift-off, galling between components, excessive deflection, yielding of steel, wrinkling of stainless steel, and flow or bond failure of PTFE. Perform testing to validate performance of replaced or repaired bearings as directed.
- Costs associated with testing project samples failing to conform to these requirements are borne by the bearings manufacturer. This cost will be assessed at the rate established by Construction Division at the time of testing.
- 3.3.3. **Storage.** Store HLMR bearings horizontally in a dry, sheltered area. Provide moisture and dust-resistant wrapping maintained in good condition until installation. Lift bearings only from the undersides. Protect bearings from damage, dirt, oil, grease, and other foreign substances.
- 3.3.4. **Field Methods.** Provide concrete surfaces for bearing areas under HLMR bearings in accordance with Section 420.4.9., "Treatment and Finishing of Horizontal Surfaces," unless indicated otherwise on the plans or the HLMR bearing shop drawings.
- Do not disassemble bearings unless otherwise approved by the Engineer with the guidance of the bearing fabricator. Clean any contaminated sliding surfaces as directed by the fabricator.
- Place HLMR bearings on preformed fabric pads as indicated in Section 441.3.11.6., "Bearing and Anchorage Devices," unless indicated otherwise on the plans or the shop drawings. Refer to the plans for temperature setting corrections for all bridges and bearing alignment relative to a chord for curved bridges. Perform such adjustments as directed if the plans do not address these requirements.
- Exercise care in any field-welding required for the installation of an HLMR bearing to prevent damage to the elastomer, disc element, PTFE, or stainless steel surface. Perform repair of damage to the prime coat on the bearings and apply the final appearance coat in accordance with Item 446, "Field Cleaning and Painting Steel."
- Damaged bearings will be subject to rejection and require replacement as directed.

4. MEASUREMENT

- 4.1. **Plain and Laminated Elastomeric Bearings.** When plain and laminated elastomeric bearings are specified on the plans to be a pay item, measurement will be by each bearing.
- 4.2. **Sliding Elastomeric Bearings.** Sliding elastomeric bearings will be measured by each bearing.
- 4.3. **HLMR Bearings.** HLMR bearings will be measured by each bearing in a specified load range.

5. PAYMENT

- 5.1. **Plain and Laminated Elastomeric Bearings.** Plain and laminated elastomeric bearings used with precast prestressed concrete or rolled steel members will not be paid for directly but will be subsidiary to the pertinent Items.

For plain and laminated elastomeric bearings used with post-tensioned concrete superstructures, and with steel girders when specified as a pay item, the work performed and materials furnished in accordance with this Item and measured as provided under "Measurement" will be paid for at the unit price bid for "Elastomeric Bearing" of the type specified. This price is full compensation for materials, including anchor bolts, top plates, steel special components; installation; and tools, equipment, labor, and incidentals.

- 5.2. **Sliding Elastomeric Bearings.** The work performed and materials furnished in accordance with this Item and measured as provided under "Measurement" will be paid for at the unit price bid for "Sliding Elastomeric Bearing" of the type specified. This price is full compensation for the stainless steel faced top (sole) plate, the PTFE-faced steel plate vulcanized to the top of a laminated elastomeric bearing pad, the steel special components, the anchor bolts required to connect the bearing between superstructure and substructure; installation; and tools, equipment, labor, and incidentals.

- 5.3. **HLMR Bearings.** The work performed and materials furnished in accordance with this Item and measured as provided under "Measurement" will be paid for at the unit price bid for "HLMR Bearing" of the type specified. This price is full compensation for the stainless steel faced top (sole) plate, the PTFE-faced steel plate attached to the top bearing plate, the polyether urethane disc or elastomer layer, lateral guide components, shear restriction devices or outer cylinder pot, pot bearing seals, the anchor bolts required to connect the bearing to the supporting structure; installation; and tools, equipment, labor, and incidentals.

Item 438

Cleaning and Sealing Joints



1. DESCRIPTION

Clean and seal joints in new or existing rigid concrete pavements and bridge decks. Resize joints in rigid concrete pavements and approach slabs as shown on the plans.

2. MATERIALS

Use sealants of the class specified on the plans that meet the requirements of DMS-6310, "Joint Sealants and Fillers." Use primers recommended by the manufacturer of the sealant if required.

Provide backer rods that are circular and are 25% larger than the joint opening. Use backer rods compatible with the sealant that do not react or bond together.

3. EQUIPMENT

Use equipment that meets sealant manufacturer's recommendations. Use air compressors equipped with appropriate filters for removing oil and water from the air. Provide concrete saws with sufficient capacity to cut full depth of concrete pavement, approach slabs, and pan girder joints.

4. CONSTRUCTION

Submit information from the sealant manufacturer showing recommended equipment and installation procedures before starting work. All equipment and procedures will be subject to approval. If the equipment causes damage to dowels, reinforcing steel, concrete, base, sub-base, or subgrade, repair the damage and change the procedure and equipment to prevent further damage.

- 4.1. **Preparation.** Remove all debris, dirt, dust, saw-cuttings, and other foreign material from joint by an approved method. Collect and dispose of all the removed material.

Remove existing preformed bituminous fiber board material or other spacer material the full depth of the joint along with all other debris in the joint opening. Resize the joint sealant space by sawing to the width and depth shown on the plans to accommodate the type of sealant specified.

Clean debris from the diaphragm windows below the joints on concrete slab and girder bridges.

Abrasive blast clean the vertical faces of joints armored with steel to remove all visible rust, paint, mill scale, and other forms of contamination, leaving a white metal appearance. Clean concrete and other surfaces by method approved and in accordance with the manufacturer's specifications before placing sealant. Air blast the joint after cleaning to remove all dust.

Saw-cut concrete pavement and concrete approach slab full depth to provide joint opening as shown on the plans and as directed. Clean all debris out of the joint full depth of concrete pavement.

- 4.2. **Sealing.** Place the sealant in accordance with the manufacturer's recommended procedures. Apply the primer, when required, at the specified rate and time interval before applying the sealant. Apply the sealant to dry joint surfaces unless otherwise recommended by the sealant manufacturer. Tool any sealant material that is not self-leveling to force the sealant against the joint surfaces.

Place approved support spacers into joints as shown on the plans for concrete pavement. Place a backer rod in the joint opening to prevent the sealant from flowing through the joint and to hold the sealant at its required elevation unless directed otherwise. Set the top of the sealant and thickness of sealant as shown on the plans. Do not place sealant in an expansion-type joint if surface temperature is below 55°F or above 90°F.

5. MEASUREMENT

When specified on the plans to be a pay item, this Item will be measured by the foot of sealant placed.

6. PAYMENT

Unless otherwise specified on the plans, the work performed and materials furnished as this Item requires will not be paid for directly but will be subsidiary to bid items of the Contract.

When shown as a pay item, the work performed and materials furnished in accordance with this Item and measured as provided under "Measurement" will be paid for at the unit price bid for "Cleaning and Sealing Existing Joints," "Cleaning and Sealing Joints" of the class, if specified, and "Cleaning Existing Joints," and "Resizing and Sealing Joints." This price is full compensation for furnishing all materials; sawing, routing, and cleaning and installing; disposing of debris; and equipment, labor, tools, and incidentals.

Item 439

Bridge Deck Overlays



1. DESCRIPTION

Overlay concrete bridge deck surface with concrete overlay (CO), latex-modified concrete overlay (LMC), or multi-layer polymer overlay (MLPO).

2. MATERIALS

Provide materials conforming to the pertinent requirements of the following Items except as noted below.

- Item 421, "Hydraulic Cement Concrete," and
- Item 440, "Reinforcement for Concrete."

2.1. **Latex for LMC.** Provide latex admixture meeting the requirements of DMS-4640, "Chemical Admixtures for Concrete."

Store latex at temperatures between 40°F and 85°F. Do not allow latex to freeze.

2.2. **Grout for CO or LMC.** Provide grout for bonding new concrete to existing concrete consisting of equal parts by weight of hydraulic cement and sand when shown on the plans. Mix with sufficient water to form a stiff slurry, which can be applied with a stiff brush or broom to the existing concrete in a thin, even coating that will not run or puddle in low spots.

2.3. **Materials for MLPO:**

2.3.1. **Crack Sealant.** Furnish epoxy crack sealant conforming to DMS-6100, "Epoxies and Adhesives," Type IV, and compatible with the multiple layer polymer overlay determined by the manufacturer of the overlay system. Epoxy, methacrylate, or polymer crack sealant not meeting the requirements of DMS-6100, "Epoxies and Adhesives," for Type IV epoxy may be used if part of the manufacturer's overlay system.

2.3.2. **Sand.** Furnish finely graded, oven-dry mason's sand (for broadcast over crack sealant) that is compatible with the multiple layer polymer overlay determined by the manufacturer of the overlay system.

2.3.3. **Aggregate.** Furnish aggregate (for polymer overlay) that conforms to the gradation specified in Table 1. Use an angular-shaped aggregate with a Mohs scale hardness of 6 or greater. Use aggregates that are non-friable, non-polishing, clean, kiln-dried to a maximum moisture content of 0.2% by weight, and free of dirt, clay, asphalt, and other organic materials. All aggregate materials retained in the #8 sieve must have at least 1 mechanically fractured face. Aggregate not meeting the gradation requirements in Table 1 may be accepted if part of an overlay system.

Table 1
Aggregate Gradation Requirements¹

	Sieve #4	Sieve #8	Sieve #16	Sieve #30
% by weight passing sieve	100%	30-75%	0-5%	0-1%

1. Based on the washed sieve analysis given in Tex-200-F, Part II.

2.3.4. **Resin for Polymer Overlay.** Furnish a polymer resin composed of epoxy, modified epoxy or methyl methacrylate (MMA). The resin (neat) and resulting polymer overlay system (composite consisting of resin and aggregate) must comply with the property requirements specified in Table 2. Furnish a 2-component, 100% solid, 100% reactive resin free of volatile solvents for epoxy-based resin. Formulate the resin to volumetric mixing proportions such as 1 part "A" to 1 part "B" according to the overlay system manufacturer's

recommendations. Furnish a flexibilized methyl methacrylate (Component A) and a powdered hardener (Component B) for MMA resin.

Table 2
Requirements for Resin and Polymer Overlay System

Property	Requirement ¹	Test Method
Viscosity (neat)	7–70 poises	Tex-614-J
Gel time (neat)	15 min. minimum	Tex-614-J
Compressive strength at 5 hr. (composite)	1,000 psi minimum	Tex-618-J
Compressive strength at 48 hr. (composite)	3,000 psi minimum	Tex-618-J
Tensile strength at 7 days (neat)	1,800–5,000 psi	Tex-618-J
Resilience at 48 hr. (neat)	70% minimum	Tex-618-J
Elongation at 7 days (neat)	30% minimum	Tex-618-J
Bond Strength (neat)	250 psi minimum	Tex-614-J
Shore D hardness (neat)	60–70	ASTM D2240
Absorption at 24 hr. (neat)	1% maximum	ASTM D570
Thermal compatibility (composite)	No delamination of overlay	ASTM C884 with modifications; one cycle is 8 hr. at 60°C followed by 16 hr. at -21°C. Determine results after 9 cycles.

1. Values are based on composite specimens or neat samples cured or aged and tested at 24°C (75°F).

3. EQUIPMENT

3.1. Surface Preparation Equipment.

3.1.1. **Concrete Removal and Surface Preparation.** Provide equipment meeting the requirements of Item 483, “Concrete Bridge Deck Surfacing.”

3.1.2. **Abrasive Blasting.** Provide equipment capable of removing oil, dirt, slurry, curing compound, laitance, etc., from the surface of the concrete.

3.1.3. **Sawing.** Provide equipment capable of sawing concrete to the specified depth when required.

3.1.4. **Power-Driven Chipping Tools.** Provide tools not heavier than a nominal 30 lb. class for bulk removal of concrete.

3.1.5. **Chipping Hammers.** Provide chipping hammers not heavier than a nominal 15 lb. class to remove concrete beneath any reinforcing bars.

3.1.6. **Cleaning.** Provide magnetic equipment followed by vacuum equipment to remove spent steel shot. Provide vacuum equipment for final cleaning of prepared surfaces unless otherwise approved.

3.1.7. **Test Apparatus for MLPO.** Provide all equipment to perform tensile adhesion test prescribed in ASTM C1583.

3.2. Proportioning and Mixing Equipment.

3.2.1. **Grout Mixer.** Provide a volumetric continuous or mortar mixer.

3.2.2. **Concrete Overlay.** Follow applicable provisions of Item 421, “Hydraulic Cement Concrete.”

3.2.3. **Latex-Modified Concrete Overlay.** Follow the applicable provisions of Item 421, “Hydraulic Cement Concrete.” Proportion and mix the latex-modified concrete at the project site using a suitable approved mixer capable of thoroughly mixing the ingredients to a uniform consistency.

3.2.4. **Multi-Layer Polymer Overlay.** Furnish equipment suitable for mixing and placing the overlay system components recommended by the manufacturer of the overlay system. Furnish paint rollers or notched squeegees to apply crack sealant and resin.

Provide aggregate spreading equipment or methods capable of uniformly applying the aggregate so 100% of the polymer material is covered to excess.

3.3. **Placing and Finishing Equipment.**

3.3.1. **Hand Tools.** Provide sufficient hand tools for placing, consolidating, striking off, and finishing stiff plastic concrete.

3.3.2. **Finishing Equipment for Concrete Overlay.** Provide an approved surface vibrator moving ahead of the finishing machine or an approved vibrating screed for overlay consolidation. Provide work bridges or other suitable facilities to perform all finishing operations.

3.3.3. **Finishing Equipment for Latex-Modified Concrete Overlay.** Provide a mechanical strike-off to ensure a uniform thickness of concrete in front of the screed. Design the bottom face of the screed to minimize tearing of the surface of the plastic concrete.

Provide a finishing machine capable of forward and reverse motion under positive control. Make appropriate provisions for raising the screeds to clear the screeded surface for traveling in reverse. Equip the finishing machine to travel on and screed off of any adjacent completed lane without damaging it. Use approved manual screeds and vibrators to consolidate and finish small or irregular areas inaccessible to the finishing machine. Provide work bridges or other suitable facilities to perform finishing operations and density checks.

4. **CONSTRUCTION OF CONCRETE OR LATEX MODIFIED CONCRETE OVERLAYS**

4.1. **General.** Provide for approval a detailed work plan including equipment and manpower before beginning any work.

The Engineer will inform the Contractor if night placements become necessary. No additional compensation will be provided for night placements of concrete. Provide sufficient lighting to make quality workmanship and adequate inspection possible during night placements. Lighting must be approved before operations begin.

Provide sufficient labor and equipment for proportioning, mixing, placing, and finishing concrete overlay at a rate of at least 40 ft. of finished overlay per hour. Do not allow traffic other than construction equipment for the overlay on any portion of the prepared bridge deck before the overlay has been placed. Provide side and end forms for supporting the screed and containing the overlay concrete. Provide reinforcement, when required, in accordance with Item 440, "Reinforcement for Concrete," and the details shown on the plans.

Place concrete only when the air or deck temperature is 40°F or above and the concrete temperature is between 50°F and 85°F. Do not cart concrete batches over the completed overlay until the overlay concrete has attained a 3,000-psi compressive or 425-psi flexural strength. If carts are used, provide timber planking of at least 3/4 in. thickness for the remainder of the curing period. Provide carts equipped with pneumatic tires. Do not interrupt curing operations for the purpose of carting concrete over finished slabs.

Open the structure with the completed overlay to normal construction traffic or to the traveling public in accordance with Section 422.4.1., "Schedule Restrictions and Inspection Hold-Points."

4.2. **Classification and Mix Design.** Provide a mix design in accordance with Item 421, "Hydraulic Cement Concrete." Use a water reducing chemical admixture as necessary to achieve the desired consistency without exceeding the specified water to cementitious material ratio. Provide a mix design with an entrained air content of the fresh concrete of 6% with a tolerance of $\pm 1\%$ when tested in accordance with Tex-414-A or Tex-416-A together with the following requirements:

4.2.1. **Concrete Overlay.** Provide Class CO concrete with a coarse aggregate factor of at least 0.55.

4.2.2. **Latex-Modified Concrete.** Provide Class LMC concrete with a cement content of at least 658 lb. per cubic yard, a latex admixture content of at least 24.5 gal. per cubic yard, and a water content of no more than 18.9

gal. per cubic yard. Provide a mix design using a coarse aggregate volume of 30% to 45% by weight of the total aggregate and a weight ratio of cement-to-sand to coarse aggregate of 1.0:2.8:1.7 based on aggregate in a saturated surface-dry condition. Use a commercially available antifoaming agent with the polymer modifier as necessary to control the air content in the mix.

- 4.3. **Surface Preparation.** Do not scarify concrete surfaces with a grooved or tined finish unless shown on the plans. Prepare these surfaces by abrasive blasting or water-injected abrasive blasting as required to remove dirt, oil, curing compound, laitance, surface mortar, and other material that would inhibit bonding of the overlay, but leave the striations intact.

Scarify the surfaces of slabs to be rehabilitated to the depths shown on the plans using the method specified in accordance with Item 483, "Concrete Bridge Deck Surfacing."

Remove and dispose of deteriorated or delaminated areas of concrete as shown on the plans or as determined by the use of a sounding hammer, chain drag, or other acceptable device, and by visual inspection after scarifying as approved.

Remove and repair deteriorated concrete below the indicated depth of scarification in accordance with Item 429, "Concrete Structure Repair." Use only hydraulic-cement concrete for these repairs. Ensure the repaired surface is flush with the surrounding scarified surfaces. Allow the repair concrete to cure before placing the overlay concrete unless approved otherwise. When approved, placing repair concrete in partial depth deck repairs may be done concurrently when placing the overlay concrete.

Use a jackhammer not heavier than a nominal 30 lb. class to remove deteriorated concrete in small areas not accessible to the mechanical scarifier, and to spot-remove small areas of deteriorated concrete to a depth down to the existing top reinforcing steel. This class of jackhammer may also be used for concrete removal between existing reinforcing bars to a greater depth. Use chipping hammers not heavier than a nominal 15 lb. class to remove concrete from beneath any reinforcing bars near the perimeter of the removal area. Avoid cutting, stretching, or damaging exposed reinforcing steel by direct impact of these power tools. Repair or replace reinforcing steel damaged during the concrete removal process at no additional expense to the Department. Operate all jackhammers and chipping hammers at an angle of 45° or less measured from the surface of the slab.

Remove the concrete surrounding the reinforcing bars to a minimum depth of 1/2 in. below the bar to permit the new concrete to bond to the entire periphery of the exposed bar if reinforcing steel is exposed during bridge deck surfacing.

Clean all exposed reinforcing steel, scarified surfaces, and newly exposed concrete surfaces including construction joints against curbs or parapet walls by wet or dry abrasive blasting. Blast corroded reinforcing steel to gray metal. Remove and place all blast debris in an approved disposal site. Repair or replace damaged reinforcing steel as required.

Place, support, and tie new reinforcing steel on prepared surface in accordance with Item 440, "Reinforcement for Concrete," when shown on the plans.

- 4.4. **Placing and Finishing Concrete.** Grade the screed rails or headers to ensure the concrete is finished to the required profile. Place the rails or headers outside the area to be overlaid unless otherwise approved. Provide anchorage of headers or supporting rails for horizontal and vertical stability as necessary. A hold-down device anchored into the concrete will not be permitted unless the concrete is to be subsequently overlaid. Obtain approval for plans for anchor support of headers or rails before beginning work.

Provide the overlay thickness specified on the plans. Adjust the screed and screed rail as necessary to provide the approved grade and required thickness. Check the clearance between the screed and existing surface for nonreinforced overlays by attaching a filler block with a thickness of 1/8 in. less than the overlay thickness to the bottom of the screed. Pass the screed over the area to be overlaid with the filler block in place. Correct any areas with insufficient clearance by adjusting the screed and rail system or by chipping or

scarifying as approved by the Engineer. Check screed clearance and reinforcement cover for reinforced overlays as approved by the Engineer.

Construct longitudinal joints at locations shown on the plans or as approved. Construct a straight and vertical edge at transverse and longitudinal construction joints. Saw joints before placing the adjacent overlay course.

Install expansion joints in the overlay at the same locations as the expansion joints in the deck.

Provide clean surface before moistening surface to receive overlay by clean air blasting or water blasting to remove all dust, spent abrasives, laitance, and other contaminants that can reduce bond strength of overlay to concrete surface.

Moisten the prepared surface to a near saturated surface-dry condition just before placing the overlay concrete. Remove standing water from the surface before placing the overlay concrete.

Do not use bonding grout unless otherwise required on the plans or by this Item. When bonding grout is required, moisten the prepared surface to a near saturated surface-dry condition before placing bonding grout. Scrub a thin coating of grout into the prepared surface immediately before placing the concrete. Ensure all surfaces including vertical joints receive a thorough, even coating and that no excess grout collects in pockets. Apply the grout so it does not become dry before it is covered with concrete.

Coat areas of the bridge deck where concrete has been removed below the top mat of reinforcing steel with bonding grout if required, and fill them with overlay concrete or Class S concrete as applicable to cover the reinforcing steel, if deck repairs were not previously finished. Adequately consolidate and rough float these areas just ahead of the overlay placement. Stop all operations if grout dries out, and remove the grout using high-pressure water blasting.

Place and mechanically strike off the overlay concrete slightly above the final grade. Follow this strike-off by mechanically consolidating and screeding the surface to the final grade. Vibrate all concrete into the corners and angles of the edges. Hand-finish the surface with a float as necessary to produce a tight, uniform surface.

Assure dense, watertight construction joints by properly consolidating the concrete and float-finishing the top surface of the joint flush with the adjacent concrete.

Meet the straightedge and finishing requirements specified in Section 422.4.7., "Finish and Interim Curing of Bridge Slabs," for the finishing of the concrete overlay.

- 4.5. **Curing.** Apply wet-burlap to cure the overlay as soon as possible after the concrete has been textured. Overlay that dries out or cracks before the wet burlap is applied will be rejected. Keep the burlap continuously wet for 48 hr. for LMC and for 4 days for CO overlays. Allow LMC overlay to air cure for an additional 48 hr. before opening to traffic. Water-cure the CO overlay in accordance with Section 422.4.8., "Final Curing," for an additional 4 days. Do not place traffic on overlay until required strength is obtained. Maintain the surface temperature of the concrete above 40°F for the required curing period. Remove and replace rejected overlay concrete at no additional cost to the Department.
- 4.6. **Final Surface Texture.** Provide final surface texture to hardened concrete surface when required and in accordance with Section 422.4.11, "Final Surface Texture."

5. CONSTRUCTION FOR MULTI-LAYER POLYMER OVERLAY

- 5.1. **Contractor Submittals.** Submit to the Engineer the following documentation, and obtain approval before work commences:

- 5.1.1. **Product Data.** Submit a list of materials to be used. Provide manufacturer's product data sheets that include: material specifications for the proposed polymer overlay system; mechanical, physical, and chemical properties; environmental durability; limitations; maintenance instructions; and general recommendations on storage, mixing, application, cleanup, and disposal of materials. Submit a resin mix design which includes the name and type of all ingredients, the mix ratios to be used, and the application rate for each material. Include in the submittal a chart showing the expected cure times (in minutes) at the corresponding temperatures between 40°F and 100°F (in 10°F increments) for the proposed mix designs.
- 5.1.2. **Certification of Compliance.** Provide a certificate of compliance from an independent, nationally recognized laboratory stating the materials to be used meet the requirements of this specification. Furnish samples of the materials to be used as required by the Engineer.
- 5.1.3. **Material Safety Data Sheets.** Provide manufacturer's Material Safety Data Sheets (MSDS) for all materials to be used on site and certification the materials conform to local, state, and federal environmental and worker's safety laws and regulations.
- 5.1.4. **Work Plan.** Submit a work plan for constructing the overlay including at least the following: proposed equipment, materials, and procedures for preparing the surface and placing the overlay; proposed removal and replacement of existing non-compatible deck repair materials; repair procedures for patching deteriorated areas and repairing cracks exposed by surface preparation; and an anticipated schedule for traffic control. The work plan must meet the approval of the manufacturer of the polymer overlay system. Any deviations from the application prescribed by this specification must be approved.
- 5.1.5. **Technical Support Representative.** Submit name and qualifications of overlay system manufacturer's representative who will be on the jobsite at initiation of work. The Engineer may request the manufacturer's representative return to the jobsite to address issues that may arise during the work.
- 5.2. **Handling of Materials.** Transport and store polymer materials in their original containers in accordance with the manufacturer's recommendations and requirements. Clearly mark containers as "Part A—Contains Resin" or "Part B—Contains Curing Agent," and include the following information on each container: name of product, name and address of manufacturer, mixing proportions and instructions, lot and batch numbers, date manufactured, and quantity contained. Store aggregates in a clean and moisture-free atmosphere that is protected from all potential sources of contamination.
- 5.3. **Deck Repair.** Repair the deck in accordance with Item 429, "Concrete Structure Repair," before surface preparation and if indicated on the plans. Use only repair materials that are compatible with the crack sealant and overlay systems the system manufacturers' determined. Do not use phosphate-based repair materials unless the overlay system manufacturer determines them to be compatible.
- 5.4. **Surface Preparation.** Prepare the entire concrete deck surface after all repairs have cured in accordance with the repair material manufacturer's recommendations by removing weak concrete, asphaltic materials, oils, dirt, rubber, curing compound, paint, carbonation, laitance, weak surface mortar, and other potentially detrimental materials that, in the opinion of the overlay system manufacturer's representative or the Engineer, would prevent proper bonding to or curing of the overlay material. Use power-driven hand tools only in areas where mechanical surface preparation equipment cannot reach. Conduct all hand tool operations before using mechanical surface preparation equipment. Select a surface preparation technique such as size and flow of abrasive or water pressure, travel speed, and number of passes that will provide a surface profile equivalent to ICRI Guide No. 03732, Profile 5 or higher. Use advanced surface removal methods in accordance with Item 483, "Concrete Bridge Deck Surfacing," when shown on the plans.
- Use compressed air equipment to clean all dust, debris, and concrete fines from the deck surface and vertical faces of curbs and barrier walls up to a height of 1 in. above the overlay after hand tool and mechanical surface preparation is complete.
- Do not allow public traffic onto any portion of the deck that has been prepared and cleaned, or onto any area where all courses have not been placed and allowed to fully cure. Overlay application equipment only is

allowed to drive on the prepared deck surface or on any intermediate course during the overlay application as long as these surfaces are not contaminated or otherwise damaged.

Protect all prepared surfaces from subsequent contamination, and remove any contamination found on the deck or intermediate courses after initial preparation. The deck surfaces will be inspected for presence of contaminants immediately before placing sealant or any course of the overlay system. Apply the sealant or first course of the overlay within 24 hr. of surface preparation, and place all intermediate courses of the overlay within 7 days of initial surface preparation.

- 5.5. **Tensile Adhesion Testing.** Conduct direct pull-off tests in accordance with ASTM C1583 to determine the adequacy of the selected surface preparation (size of shot, flow of shot, forward speed of blast machinery, number of passes, blast pressure, etc.) and cleaning methods. Conduct these tests when the surface temperature is below 80°F. Core through the test overlay to a depth of 0.5 in. into the underlying concrete.

Conduct one tensile adhesion test for each span or 500 sq. yd. whichever is smaller. The Engineer will determine test site locations for each representative portion of deck. In addition to representative portion tests, the Department may require additional tensile adhesion tests be performed on areas inaccessible to mechanical surface preparation equipment. The Contractor must remove residual test materials adhering to the deck, make necessary adjustments to the surface preparation methods, and retest all representative portions with failing test results, at no additional cost to the Department, until one passing tensile adhesion test result (from 3 pull-off tests) is obtained for each area tested.

One tensile adhesion test result is the average of 3 pull-off tests conducted over a 1 ft. × 3 ft. test site prepared with at least 1 layer of polymer. Surfaces with tension adhesion test results demonstrating average tensile bond strengths of at least 250 psi are considered acceptable.

- 5.6. **Application of Crack Sealant.** Apply the crack sealant in conjunction with the first layer of polymer overlay if the crack sealant and overlay system manufacturers determine it is compatible and the Engineer approves. Do not place crack sealant on new hydraulic cement concrete that is less than 28 days old unless the overlay system manufacturer allows it in writing. Allow the deck and all cracks to dry fully before applying crack sealant. Place the crack sealant on repairs only after completion of curing of the repair material and with the concurrence, in writing, of the polymer overlay system manufacturer. Identify moisture in the deck using a plastic sheet left taped in place for a minimum of 2 hr. (per ASTM D4263) or other approved methods.

Mix, place, and cure the crack sealant in accordance with the sealant manufacturer's written recommendations. Do not apply crack sealant if the ambient air temperature is expected to drop below the sealant manufacturer's recommended application temperature range within 8 hr. after application or if the gel time is expected to drop below 10 min.

Broadcast sand at the rate recommended by the sealant manufacturer in such a manner that complete coverage of the treated area is attained while the crack sealant is still tacky. Cure treated area until vacuuming or sweeping can be conducted without tearing or otherwise damaging the treated surface.

Repair at no additional cost to the Department any areas in which the treated surface is damaged, contaminated, or does not receive adequate sand embedment before gelling to create a surface compatible with the overlay system as the overlay system manufacturer determines.

- 5.7. **Application of Polymer Overlay.** Do not place polymer overlay on new hydraulic cement concrete that is less than 28 days old unless otherwise approved. Place polymer overlay on repairs only after completion of curing of the repair material and with the concurrence, in writing, of the polymer overlay system manufacturer. Allow the deck to dry fully before applying polymer overlay. Identify moisture in the deck using a plastic sheet left taped in place for at least 2 hr. (per ASTM D4263) or other approved methods. Remove all loose sand or aggregate, and attain approval from the Engineer before placement of each polymer overlay course.

Mix, place, and cure the polymer overlay materials in accordance with the overlay system manufacturer's written recommendations. Do not apply polymer overlay if the ambient air temperature is expected to drop

below the overlay system manufacturer's recommended application temperature range within 8 hr. after application or if the gel time is expected to drop below 10 min. MMA overlays may be placed as a slurry, with resin and aggregate pre-mixed, in accordance with the manufacturer's recommendations.

Broadcast aggregate onto the still fluid resin binder until a dry layer of aggregate is present over the entire surface. Immediately broadcast additional aggregate until a dry surface is established if wet spots develop. Accomplish all aggregate broadcasting while binder is still fluid. Cure each course of overlay until vacuuming or sweeping can be conducted without tearing or otherwise damaging the overlay surface. Repair at no additional cost to the Department any intermediate courses in which the treated surface is damaged, contaminated, or does not receive adequate aggregate before gelling to create an intermediate surface compatible with the next overlay course as the overlay system manufacturer determines. Repair damaged areas in accordance with the overlay system manufacturer's recommendations at no additional cost to the Department if the final polymer overlay surface is damaged or marred.

The nominal finished overlay thickness is at least 3/8 in. measured from the highest point on the deck surface to the peaks of the aggregate. Apply the polymer with aggregates in multiple courses (minimum of 2 for epoxy systems, and at least one course for slurry applied MMA) as prescribed by the overlay system manufacturer but at rates no less than specified in Table 3. Stagger and overlap longitudinal joints between successive courses so no ridges form.

Table 3
Polymer and Aggregate Application Rates

Course	Polymer (gal./100 sq. ft.)	Aggregate (lb./sq. yd.)
Epoxy 1	Not less than 2.5	> 10
Epoxy 2	Not less than 5.0	> 14
MMA 1	Not less than 4.0	> 13

Protect all bridge deck expansion joints from intrusion of polymer overlay materials. Remove overlay over all expansion joints within 12 hr. of application and before opening the overlay surface to traffic. Removal may be accomplished by scoring the overlay before gelling, by saw-cutting after curing, or by other method approved by the overlay system manufacturer.

Obtain approval to open any course to traffic. Obtain approval of cleaning and surface preparation methods for initial courses that were opened to traffic before the final course was applied. Do not allow construction traffic on the final course until it has cured sufficiently to prevent damage by wheel loads. Minimum curing periods will be in accordance with the submitted curing time chart.

- 5.8. **Repair of Defects.** The Department will examine the completed work for defects. Immediately repair or take corrective action for delaminations, raveling, weathering, incomplete aggregate coverage, or other defects found during the Department's examination.

6. MEASUREMENT

Concrete overlay, latex-modified concrete overlay, and multi-layer polymer overlay will be measured by the square yard of surface overlaid using the dimensions shown on the plans. Overlay is a plans quantity measurement item. The quantity to be paid is the quantity shown in the proposal, unless modified by Article 9.2., "Plans Quantity Measurement." Additional measurements or calculations will be made if adjustments of quantities are required.

7. PAYMENT

The work performed and materials furnished in accordance with this Item and measured as provided under "Measurement" will be paid for at the unit price bid for "Concrete Overlay," "Reinforced Concrete Overlay," and "Latex-Modified Concrete Overlay" of the specified depth or for "Multi-Layer Polymer Overlay."

Payment for "Concrete Overlay" or "Latex-Modified Concrete Overlay" is full compensation for cleaning surface, furnishing and placing grout; cleaning and restoration of reinforcing steel; furnishing and placing reinforcing steel; and furnishing, placing, finishing and curing the concrete overlay.

Payment for "Multi-Layer Polymer Concrete Overlay" is full compensation for: surface preparation; surface preparation testing; presence of overlay system manufacturer's representative at initiation of the work and as requested; furnishing and applying crack sealant and multiple-layer polymer concrete overlay courses; repairing damaged or marred overlay surfaces; and all materials, labor, tools, equipment, and incidentals.

These prices are full compensation for materials, tools, equipment, labor, and incidentals.

Repair of deteriorated concrete below the level of scarification will be paid for in accordance with Item 429, "Concrete Structure Repair."

Concrete removal and surface preparation beyond cleaning utilizing air, water, and abrasive blasting will be paid for in accordance with Item 483, "Concrete Bridge Deck Surfacing," when overlaying existing bridge.

Item 440

Reinforcement for Concrete



1. DESCRIPTION

Furnish and place reinforcement of the type, size, and details shown on the plans.

2. MATERIALS

Use deformed steel bar reinforcement unless otherwise specified or allowed.

- 2.1. **Approved Mills.** Before furnishing steel, producing mills of reinforcing steel for the Department must be pre-approved in accordance with DMS-7320, "Qualification Procedure for Reinforcing Steel Producing Mills," by the Construction Division. The Department's MPL has a list of approved producing mills. Reinforcing steel obtained from unapproved sources will not be accepted.

Contact the Construction Division with the name and location of the producing mill for stainless reinforcing steel, low carbon/chromium reinforcing steel, or dual-coated reinforcing steel at least 4 weeks before ordering any material.

- 2.2. **Deformed Steel Bar Reinforcement.** Provide deformed reinforcing steel conforming to one of the following:

- ASTM A615, Grades 60, 75, or 80;
- ASTM A996, Type A, Grade 60;
- ASTM A996, Type R, Grade 60, permitted in concrete pavement only (Furnish ASTM A996, Type R bars as straight bars only and do not bend them. Bend tests are not required.); or
- ASTM A706, Grades 60 or 80.

Provide the grade of reinforcing steel shown on the plans. Provide Grade 60 if no grade is shown.

The nominal size, area, and weight of reinforcing steel bars this Item covers are shown in Table 1.

Table 1
Size, Area, and Weight of Reinforcing Steel Bars

Bar Size Number (in.)	Diameter (in.)	Area (sq. in.)	Weight per Foot (lbs.)
3	0.375	0.11	0.376
4	0.500	0.20	0.668
5	0.625	0.31	1.043
6	0.750	0.44	1.502
7	0.875	0.60	2.044
8	1.000	0.79	2.670
9	1.128	1.00	3.400
10	1.270	1.27	4.303
11	1.410	1.56	5.313
14	1.693	2.25	7.650
18	2.257	4.00	13.60

- 2.3. **Smooth Steel Bar Reinforcement.** Provide smooth bars for concrete pavement with a yield strength of at least 60 ksi and meeting ASTM A615. Provide steel conforming to ASTM A615 or meet the physical requirements of ASTM A36 for smooth bars that are larger than No. 3. Designate smooth bars by size number up to No. 4 and by diameter in inches above No. 4.

- 2.4. **Spiral Reinforcement.** Provide bars or wire for spiral reinforcement of the grade and minimum size or gauge shown on the plans.

Provide smooth or deformed wire conforming to ASTM A1064. Provide bars conforming to ASTM A615; ASTM A996, Type A; or ASTM A675, Grade 80, meeting dimensional requirements of ASTM A615.

- 2.5. **Weldable Reinforcing Steel.** Provide reinforcing steel conforming to ASTM A706 or with a maximum carbon equivalent (C.E.) of 0.55% if welding of reinforcing steel is required or desired. Provide a report showing the percentages of elements necessary to establish C.E. for reinforcing steel that does not meet ASTM A706, in order to be structurally welded. These requirements do not pertain to miscellaneous welds on reinforcing steel as defined in Section 448.4.2.1.1., "Miscellaneous Welding Applications."

Calculate C.E. using the following formula:

$$C.E. = \%C + \frac{\%Mn}{6} + \frac{\%Cu}{40} + \frac{\%Ni}{20} + \frac{\%Cr}{10} - \frac{\%Mo}{50} - \frac{\%V}{10}$$

Do not weld stainless reinforcing steel without permission from the Engineer. Provide stainless reinforcing steel suitable for welding, if required, and submit welding procedures and electrodes to the Engineer for approval.

- 2.6. **Welded Wire Reinforcement.** Provide welded wire reinforcement (WWR) conforming to ASTM A1064. Observe the relations shown in Table 2 among size number, diameter in inches, and area when ordering wire by size numbers, unless otherwise specified. Precede the size number for deformed wire with "D" and for smooth wire with "W."

Designate WWR as shown in the following example: 6 × 12 – W16 × W8 (indicating 6-in. longitudinal wire spacing and 12-in. transverse wire spacing with smooth No. 16 wire longitudinally and smooth No. 8 wire transversely).

Table 2
Wire Size Number, Diameter, and Area

Size Number (in.)	Diameter (in.)	Area (sq. in.)
31	0.628	0.310
30	0.618	0.300
28	0.597	0.280
26	0.575	0.260
24	0.553	0.240
22	0.529	0.220
20	0.505	0.200
18	0.479	0.180
16	0.451	0.160
14	0.422	0.140
12	0.391	0.120
10	0.357	0.100
8	0.319	0.080
7	0.299	0.070
6	0.276	0.060
5.5	0.265	0.055
5	0.252	0.050
4.5	0.239	0.045
4	0.226	0.040
3.5	0.211	0.035
2.9	0.192	0.035
2.5	0.178	0.025
2	0.160	0.020
1.4	0.134	0.014
1.2	0.124	0.012
0.5	0.080	0.005

Note—Size numbers (in.) are the nominal cross-sectional area of the wire in hundredths of a square inch. Fractional sizes between the sizes listed above are also available and acceptable for use.

- 2.7. **Epoxy Coating.** Provide epoxy coated reinforcing steel as shown on the plans. Before furnishing epoxy coated reinforcing steel, an epoxy applicator must be pre-approved in accordance with DMS-7330, "Qualification Procedure for Reinforcing Steel Epoxy Coating Applicators." The Department's MPL has a list of approved applicators.

Furnish coated reinforcing steel meeting the requirements in Table 3.

Table 3
Epoxy Coating Requirements for Reinforcing Steel

Material	Specification
Bar	ASTM A775 or A934
Wire or WWR	ASTM A884 Class A or B
Mechanical couplers	As shown on the plans
Hardware	As shown on the plans

Use epoxy coating material and coating repair material that complies with DMS-8130, "Epoxy Powder Coating for Reinforcing Steel." Patch no more than 1/4-in. total length in any foot at the applicator's plant.

Maintain identification of all reinforcing steel throughout the coating and fabrication process and until delivery to the project site.

Furnish 1 copy of a written certification verifying the coated reinforcing steel meets the requirements of this Item and 1 copy of the manufacturer's control tests.

- 2.8. **Mechanical Couplers.** Use couplers of the type specified in DMS-4510, "Mechanical Couplers for Reinforcing Steel," Article 4510.5.A, "General Requirements," when mechanical splices in reinforcing steel bars are shown on the plans.

Furnish only couplers pre-qualified in accordance with DMS-4510, "Mechanical Couplers for Reinforcing Steel." Ensure sleeve-wedge type couplers are not used on coated reinforcing. Sample and test couplers for use on individual projects in accordance with DMS-4510, "Mechanical Couplers for Reinforcing Steel." Furnish couplers only at locations shown on the plans.

Furnish couplers for stainless reinforcing steel with the same alloy designation as the reinforcing steel.

- 2.9. **Fibers.** Supply fibers conforming to DMS-4550 "Fibers for Concrete" at the minimum dosage listed in the Department's MPL, when allowed by the plans. Use non-metallic fibers when shown on the plans.
- 2.10. **Stainless Reinforcing Steel.** Provide deformed steel bars of the types listed in Table 4 and conforming to ASTM A955, Grade 60 or higher when stainless reinforcing steel is required on the plans.

Table 4
Acceptable Types of Deformed Stainless Steel Bar

UNS Designation	S31653	S31803	S24100	S32304
AISI Type	316LN	2205	XM-28	2304

- 2.11. **Low Carbon/Chromium Reinforcing Steel.** Provide deformed steel bars conforming to ASTM A1035, Grade 100 when low carbon/chromium reinforcing steel is required on the plans.
- 2.12. **Dual-Coated Reinforcing Steel.** Provide deformed bars conforming to ASTM A1055, Grade 60 or higher when dual-coated reinforcing steel is required on the plans.
- 2.13. **Glass Fiber Reinforced Polymer Bars (GFRP).** Provide bars conforming to the AASHTO LRFD *Bridge Design Guide Specifications for GFRP-Reinforced Concrete Bridge Decks and Traffic Railings*, Section 4, "Material Specifications" when GFRP bars are required on the plans. Provide sample certification demonstrating the GFRP bar supplier has produced bar that meets the Material Specifications 2 mo. before fabrication. Furnish certification upon shipment that the GFRP bar supplied meets the Material Specifications.

3. CONSTRUCTION

- 3.1. **Bending.** Fabricate reinforcing steel bars as prescribed in the CRSI *Manual of Standard Practice* to the shapes and dimensions shown on the plans. Fabricate in the shop if possible. Field-fabricate, if permitted, using a method approved by the Engineer. Replace improperly fabricated, damaged, or broken bars at no additional expense to the Department. Repair damaged or broken bars embedded in a previous concrete placement using a method approved by the Engineer.

Unless otherwise shown on the plans, the inside diameter of bar bends, in terms of the nominal bar diameter (d), must be as shown in Table 5.

Table 5
Minimum Inside Diameter of Bar Bends

Bend	Bar Size Number (in.)	Pin Diameter
Bends of 90° and greater in stirrups, ties, and other secondary bars that enclose another bar in the bend	3, 4, 5	4d
	6, 7, 8	6d
Bends in main bars and in secondary bars not covered above	3 through 8	6d
	9, 10, 11	8d
	14, 18	10d

Bend-test representative specimens as described for smaller bars in the applicable ASTM specification where bending No. 14 or No. 18 Grade 60 bars is required. Make the required 90° bend around a pin with a diameter of 10 times the nominal diameter of the bar.

Bend stainless reinforcing steel in accordance with ASTM A955.

- 3.2. **Tolerances.** Fabrication tolerances for bars are shown in Figure 1.

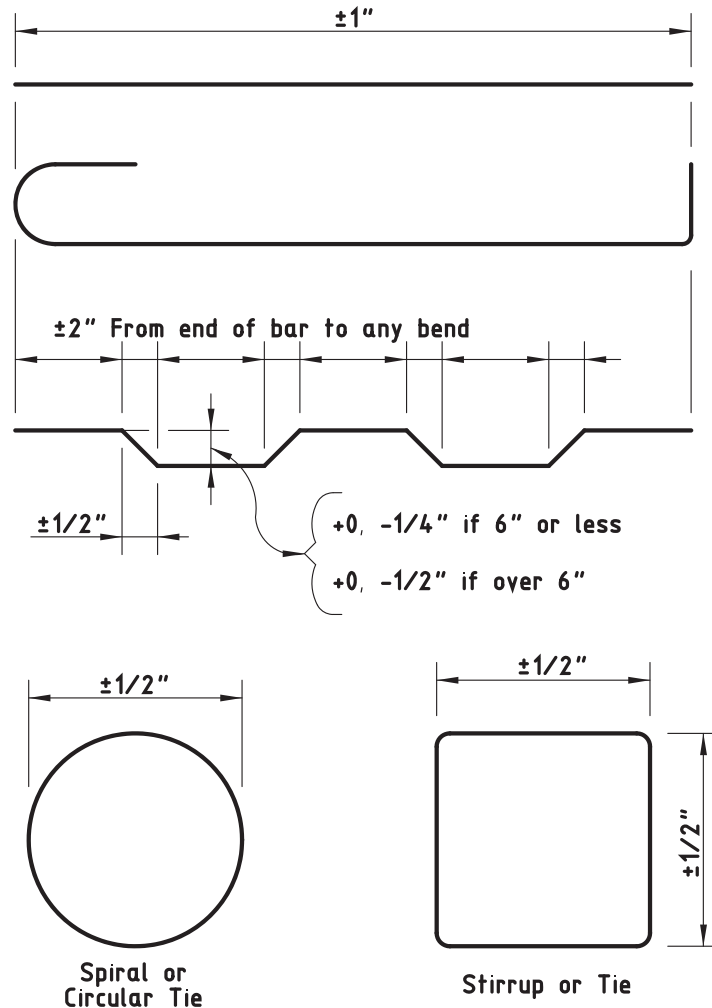

Figure 1
Fabrication Tolerances for Bars

- 3.3. **Storage.** Store reinforcement above the ground on platforms, skids, or other supports, and protect it from damage and deterioration. Ensure reinforcement is free from dirt, paint, grease, oil, and other foreign materials when it is placed in the work. Use reinforcement free from defects such as cracks and delaminations. Rust, surface seams, surface irregularities, or mill scale will not be cause for rejection if the minimum cross-sectional area of a hand wire-brushed specimen meets the requirements for the size of steel specified.

Do not allow stainless reinforcing steel to be in direct contact with uncoated reinforcing steel, nor with galvanized reinforcing steel. This does not apply to stainless steel wires and ties. Store stainless reinforcing steel separately, off the ground on wooden supports.

- 3.4. **Splices.** Lap-splice, weld-splice, or mechanically splice bars as shown on the plans. Additional splices not shown on the plans will require approval. Splices not shown on the plans will be permitted in slabs no more than 15 in. in thickness, columns, walls, and parapets.
- Do not splice bars less than 30 ft. in plan length unless otherwise approved. For bars exceeding 30 ft. in plan length, the distance center-to-center of splices must be at least 30 ft. minus 1 splice length, with no more than 1 individual bar length less than 10 ft. Make lap splices not shown on the plans, but otherwise

permitted, in accordance with Table 6. Maintain the specified concrete cover and spacing at splices, and place the lap-spliced bars in contact, securely tied together.

Table 6
Minimum Lap Requirements for Steel Bar Sizes through No. 11

Bar Size Number (in.)	Uncoated Lap Length	Coated Lap Length
3	1 ft. 4 in.	2 ft. 0 in.
4	1 ft. 9 in.	2 ft. 8 in.
5	2 ft. 2 in.	3 ft. 3 in.
6	2 ft. 7 in.	3 ft. 11 in.
7	3 ft. 5 in.	5 ft. 2 in.
8	4 ft. 6 in.	6 ft. 9 in.
9	5 ft. 8 in.	8 ft. 6 in.
10	7 ft. 3 in.	10 ft. 11 in.
11	8 ft. 11 in.	13 ft. 5 in.

- Do not lap No. 14 or No. 18 bars.
- Lap spiral steel at least 1 turn.
- Splice WWR using a lap length that includes the overlap of at least 2 cross wires plus 2 in. on each sheet or roll. Splices using bars that develop equivalent strength and are lapped in accordance with Table 6 are permitted.
- Lap the existing longitudinal bars with the new bars as shown in Table 6 for box culvert extensions with less than 1 ft. of fill. Lap at least 1 ft. 0 in. for extensions with more than 1 ft. of fill.
- Ensure welded splices conform to the requirements of the plans and of Item 448, "Structural Field Welding." Field-prepare ends of reinforcing bars if they will be butt-welded. Delivered bars must be long enough to permit weld preparation.
- Install mechanical coupling devices in accordance with the manufacturer's recommendations at locations shown on the plans. Protect threaded male or female connections, and ensure the threaded connections are clean when making the connection. Do not repair damaged threads.
- Mechanical coupler alternate equivalent strength arrangements, to be accomplished by substituting larger bar sizes or more bars, will be considered if approved in writing before fabrication of the systems.

3.5.

Placing. Place reinforcement as near as possible to the position shown on the plans. Do not vary bars from plan placement by more than 1/12 of the spacing between bars in the plane of the bar parallel to the nearest surface of concrete. Do not vary bars from plan placement by more than 1/4 in in the plane of the bar perpendicular to the nearest surface of concrete. Provide a minimum 1-in. clear cover of concrete to the nearest surface of bar unless otherwise shown on the plans.

For bridge slabs, the clear cover tolerance for the top mat of reinforcement is $-0, +1/2$ in.

Locate the reinforcement accurately in the forms, and hold it firmly in place before and during concrete placement by means of bar supports that are adequate in strength and number to prevent displacement and keep the reinforcement at the proper distance from the forms. Provide bar supports in accordance with the CRSI *Manual of Standard Practice*. Use Class 1 supports, approved plastic bar supports, precast mortar, or concrete blocks when supports are in contact with removable or stay-in-place forms. Use Class 3 supports in slab overlays on concrete panels or on existing concrete slabs. Bar supports in contact with soil or subgrade must be approved.

Use Class 1A supports with epoxy coated reinforcing steel. Provide epoxy or plastic coated tie wires and clips for use with epoxy coated reinforcing steel.

Use mortar or concrete with a minimum compressive strength of 5,000 psi for precast bar supports. Provide a suitable tie wire in each block for anchoring to the bar.

Place individual bar supports in rows at 4-ft. maximum spacing in each direction. Place continuous type bar supports at 4-ft. maximum spacing. Use continuous bar supports with permanent metal deck forms.

The exposure of the ends of longitudinals, stirrups, and spacers used to position the reinforcement in concrete pipe and storm drains is not cause for rejection.

Tie reinforcement for bridge slabs and top slabs of direct traffic culverts at all intersections, except tie only alternate intersections where spacing is less than 1 ft. in each direction. Tie the bars at enough intersections to provide a rigid cage of reinforcement for reinforcement cages for other structural members. Fasten mats of WWR securely at the ends and edges.

Clean mortar, mud, dirt, debris, oil, and other foreign material from the reinforcement before concrete placement. Do not place concrete until authorized.

Stop placement until corrective measures are taken if reinforcement is not adequately supported or tied to resist settlement, reinforcement is floating upward, truss bars are overturning, or movement is detected in any direction during concrete placement.

3.6. **Handling, Placing, and Repairing Epoxy Coated Reinforcing Steel.**

3.6.1. **Handling.** Provide systems for handling coated reinforcing steel with padded contact areas. Pad bundling bands or use suitable banding to prevent damage to the coating. Lift bundles of coated reinforcement with a strongback, spreader bar, multiple supports, or a platform bridge. Transport the bundled reinforcement carefully, and store it on protective cribbing. Do not drop or drag the coated reinforcement.

3.6.2. **Placing.** Do not flame-cut coated reinforcement. Saw or shear-cut only when approved. Coat cut ends as specified in Section 440.3.6.3., "Repairing Coating."

Do not weld or mechanically couple coated reinforcing steel except where specifically shown on the plans. Remove the epoxy coating at least 6 in. beyond the weld limits before welding and 2 in. beyond the limits of the coupler before assembly. Clean the steel of oil, grease, moisture, dirt, welding contamination (slag or acid residue), and rust to a near-white finish after welding or coupling. Check the existing epoxy for damage. Remove any damaged or loose epoxy back to sound epoxy coating.

Coat the splice area after cleaning with epoxy repair material to a thickness of 7 to 17 mils after curing. Apply a second application of repair material to the bar and coupler interface to ensure complete sealing of the joint.

3.6.3. **Repairing Coating.** Use material that complies with the requirements of this Item and ASTM D3963 for repairing of the coating. Make repairs in accordance with procedures recommended by the manufacturer of the epoxy coating powder. Apply at least the same coating thickness as required for the original coating for areas to be patched. Repair all visible damage to the coating.

Repair sawed and sheared ends, cuts, breaks, and other damage promptly before additional oxidation occurs. Clean areas to be repaired to ensure they are free from surface contaminants. Make repairs in the shop or field as required.

3.7. **Handling and Placing Stainless Reinforcing Steel.** Handle, cut, and place stainless reinforcing steel bar using tools that are not used on carbon steel. Do not use carbon steel tools, chains, slings, etc. when handling stainless steel. Use only nylon or polypropylene slings. Cut stainless steel reinforcing using shears, saws, abrasive cutoff wheels, or torches. Remove any thermal oxidation using pickling paste. Do not field bend stainless steel reinforcing without approval.

Use 16 gauge fully annealed stainless steel tie wire conforming to the material properties listed in Section 440.2.10., "Stainless Reinforcing Steel." Support all stainless reinforcing steel on solid plastic, stainless steel, or epoxy coated steel chairs. Do not use uncoated carbon steel chairs in contact with stainless reinforcing steel.

- 3.8. **Bending, Handling, Repairing, and Placing GFRP Bars.** Fabricate, handle, repair, and place GFRP bars in accordance with the AASHTO LRFD Bridge Design Guide Specifications for GFRP-Reinforced Concrete Bridge Decks and Traffic Railings, Section 5, Construction Specifications.

4. MEASUREMENT AND PAYMENT

The work performed, materials furnished, equipment, labor, tools, and incidentals will not be measured or paid for directly but will be considered subsidiary to pertinent Items.

Item 441

Steel Structures



1. DESCRIPTION

Fabricate and erect structural steel and other metals used for steel structures or for steel portions of structures.

2. MATERIALS

- 2.1. **Base Metal.** Use metal that meets Item 442, "Metal for Structures."
- 2.2. **Approved Electrodes and Flux-Electrode Combinations.** Use only electrodes and flux-electrode combinations found on the Department's MPL. To request a product be added to this list or to renew an expired approval, electronically submit a current Certificate of Conformance containing all tests required by the applicable AWS A5 specification according to the applicable welding code (for most construction, AASHTO/AWS D1.5, *Bridge Welding Code*, or AWS D1.1, *Structural Welding Code—Steel*) to the Construction Division.
- 2.3. **High-Strength Bolts.** Use fasteners that meet Item 447, "Structural Bolting." Use galvanized fasteners on field connections of bridge members when ASTM A325 bolts are specified and steel is painted.
- 2.4. **Paint Systems.** Provide the paint system (surface preparation, primer, intermediate, and appearance coats as required) shown on the plans. Provide System IV if no system is specified.
- 2.4.1. **Standard Paint Systems.** Standard paint systems for painting new steel include the following:
- 2.4.1.1. **System III-B.** Provide paint in accordance with DMS-8101, "Structural Steel Paints-Performance." Provide inorganic zinc (IOZ) prime coat, epoxy intermediate coat, and urethane appearance coat for all outer surfaces except those to be in contact with concrete. Provide epoxy zinc prime coat for touchup of IOZ.
- 2.4.1.2. **System IV.** Provide paint in accordance with DMS-8101, "Structural Steel Paints-Performance." Provide IOZ prime coat and acrylic latex appearance coat for all outer surfaces except those to be in contact with concrete. Provide epoxy zinc prime coat for touchup of IOZ.
- 2.4.2. **Paint Inside Tub Girders and Closed Boxes.** Provide a white polyamide cured epoxy for all interior surfaces, including splice plate but excluding the faying surfaces, unless otherwise shown on the plans. Provide IOZ primer meeting the requirements of DMS-8101, "Structural Steel Paints—Performance," to all interior faying surfaces and splice plates.
- 2.4.3. **Special Protection System.** Provide the type of paint system shown on the plans or in special provisions to this Item. Special Protection Systems must have completed NTPEP Structural Steel Coatings (SSC) testing regimen as a complete system, with full data available through NTPEP.
- 2.4.4. **Galvanizing.** Provide galvanizing, as required, in accordance with Item 445, "Galvanizing."
- 2.4.5. **Paint over Galvanizing.** Paint over galvanized surfaces, when required, in accordance with Item 445, "Galvanizing."
- 2.4.6. **Field Painting.** Provide field paint, as required, in accordance with Item 446, "Field Cleaning and Painting Steel."

3. CONSTRUCTION

3.1. General Requirements.

- 3.1.1. **Applicable Codes.** Perform all fabrication of bridge members in accordance with AASHTO/NSBA Steel Bridge Collaboration S2.1. Follow all applicable provisions of the appropriate AWS code (D1.5 or D1.1) except as otherwise noted on the plans or in this Item. Weld sheet steel (thinner than 1/8 in.) in accordance with ANSI/AWS D1.3, Structural Welding Code—Sheet Steel. Unless otherwise stated, requirements of this Item are in addition to the requirements of S2.1 for bridge members. Follow the more stringent requirement in case of a conflict between this Item and S2.1. Perform all bolting in accordance with Item 447, “Structural Bolting.”

Fabricate railroad underpass structures in accordance with the latest AREMA *Manual for Railway Engineering* and this Item. In the case of a conflict between this Item and the AREMA manual, the more stringent requirements apply.

- 3.1.2. **Notice of Fabrication.** Give adequate notice before commencing fabrication work as specified in Table 1. Include a schedule for all major fabrication processes and dates when inspections are to occur.

Table 1
Notice of Beginning Work

Plant Location	Notice Required
In Texas	7 days
In the contiguous United States	21 days
Outside the contiguous United States	60 days

Perform no Department work in the plant before the Engineer authorizes fabrication. The Contractor must bear all Department travel costs when changes to their fabrication or inspection schedules are not adequately conveyed to the Department.

When any structural steel is fabricated outside of the contiguous 48 states, the additional cost of inspection will be in accordance with Article 6.4., “Sampling, Testing, and Inspection.”

- 3.1.3. **Bridge Members.** Primary bridge members include:
- web and flanges of plate, tub, and box girders;
 - rolled beams and cover plates;
 - floor beam webs and flanges;
 - arch ribs and arch tie beams or girders;
 - truss members;
 - diaphragm members for curved plate girders or beams;
 - pier diaphragm members for tub girders;
 - splice plates for primary members; and
 - any other member designated as “primary” or “main” on the plans.

Secondary bridge members include:

- bracing (diaphragms, cross frames, and lateral bracing); and
- all other miscellaneous bridge items not considered primary bridge members.

- 3.1.4. **Responsibility.** The Contractor is responsible for the correctness and completeness of shop drawings and for the fit of shop and field connections.

3.1.5. **Qualification of Plants and Personnel.**

- 3.1.5.1. **Plants.** Fabrication plants that produce bridge members must be approved in accordance with DMS-7370, "Steel Bridge Member Fabrication Plant Qualification." The Department's MPL has a list of approved bridge member fabrication plants.

Fabrication plants that produce non-bridge steel members listed below must be approved in accordance with DMS-7380, "Steel Non-Bridge Member Fabrication Plant Qualification." The Construction Division maintains a list of approved non-bridge fabrication plants for the following items:

- Roadway Illumination Poles,
- High Mast Illumination Poles,
- High Mast Rings and Support Assemblies,
- Overhead Sign Support Structures,
- Traffic Signal Poles, and
- Intelligent Transportation System (ITS) Poles

The Department will evaluate non-bridge member fabrication plants for competence of the plant, equipment, organization, experience, knowledge, and personnel to produce acceptable work.

- 3.1.5.2. **Personnel.** Provide a QC staff qualified in accordance with the applicable AWS code. Provide an adequate number of qualified QC personnel for each specific production operation. QC must be on-site and independent of production personnel, as the Engineer determines. QC personnel must be proficient in utilizing the applicable plans, specifications, and test methods, and in verifying compliance with the plant QC and production procedures. Welding inspectors must be current AWS Certified Welding Inspectors for bridge member plants, and for non-bridge member plants requiring Department approval per DMS-7380, "Steel Non-Bridge Member Fabrication Plant Qualification." The QC staff must provide inspection of all materials and workmanship before the Department's inspection. Provide the Department inspector with adequate personnel and equipment needed to move material for inspection access. QC is solely the Contractor's responsibility.

- 3.1.5.3. **Nondestructive Testing (NDT).** Personnel performing NDT must be qualified in accordance with the applicable AWS code and the employer's Written Practice. Level III personnel who qualify AS Level I and Level II inspectors must be certified by ASNT for which the NDT Level III is qualified. Testing agencies and individual third-party contractors must also successfully complete periodic audits for compliance, performed by the Department. In addition, ultrasound technicians must pass a hands-on test the Construction Division administers. This will remain current provided they continue to perform testing on Department materials as evidenced by test reports requiring their signature. A technician who fails the hands-on test must wait 6 months before taking the test again. Qualification to perform ultrasonic testing will be revoked when the technician's employment is terminated or when the technician goes 6 months without performing a test on a Department project. The technician must pass a new hands-on test to be re-certified.

- 3.1.5.4. **Welding Procedure Specifications Qualification Testing.** For bridge member fabrication, laboratories performing welding procedure specifications (WPSs) qualified by testing must be approved in accordance with DMS-7360, "Qualification Procedure for Laboratories Performing Welding Procedure Qualification Testing." The Department's MPL has a list of laboratories approved to perform WPS qualification testing.

3.1.6. **Drawings.**

- 3.1.6.1. **Erection Drawings.** Submit erection drawings prepared by a licensed professional engineer, including calculations, for approval in accordance with Item 5, "Control of the Work," at least 4 weeks before erecting any portion of field-spliced (welded or bolted) girders, railroad underpasses, trusses, arches, or other members for which erection drawings are required on the plans. Include drawings and calculations for any temporary structures used to support partially erected members. Erection drawings are not required for rolled I-beam units unless otherwise noted on the plans.

Prepare erection drawings following the procedures outlined in Section 2.2 of the AASHTO/NSBA Steel Bridge Collaboration S10.1. As a minimum, include:

- plan of work area showing structure location relative to supports and all obstructions;
- equipment to be used including allowable load information;
- erection sequence for all pieces;
- member weights and center of gravity location of pieces to be lifted;
- locations of cranes, holding cranes, and temporary supports (falsework), including when to release load from temporary supports and holding cranes;
- details of falsework including specific bracing requirements with maximum allowable design wind speed clearly indicated;
- girder lifting points;
- diaphragm and bracing requirements; and
- minimum connection requirements when more than the standard requirements.

Perform girder erection analyses using UT-Lift and UT-Bridge software available on the Department's website or other suitable commercial software. Ensure temporary stresses in members being erected will not cause permanent damage and that stability is maintained throughout the erection operations. Provide actual input files and output results from UT-Lift and UT-Bridge, or graphical and hard copy results from commercial software programs.

Do not proceed if site conditions differing from those depicted on the approved erection drawings could affect temporary support stresses, erected girders, or public safety in any manner. Revise erection drawings and resubmit to the Engineer for approval before proceeding if site conditions could affect these things.

- 3.1.6.2. **Shop Drawings.** Prepare and electronically submit shop drawings before fabrication for each detail of the general plans requiring the use of structural steel, forgings, wrought iron, or castings as documented in the *Guide to Electronic Shop Drawing Submittal* available on the Bridge Division website and as directed for other items the standard specifications require.

Indicate joint details on shop drawings for all welds. Provide a title block on each sheet in the lower right corner that includes:

- project identification data including federal and state project numbers,
- sheet numbering for the shop drawings,
- name of the structure or stream for bridge structures,
- name of owner or developer,
- name of the fabricator or supplier, and
- name of the Contractor.

Provide one set of 11 × 17-in. approved shop drawings in hardcopy to the Department for the inspector at the fabrication plant.

- 3.1.6.2.1. **Bridge Members.** Prepare drawings in accordance with AASHTO/NSBA Steel Bridge Collaboration G1.3, "Shop Detail Drawing Presentation" unless otherwise approved. Print a bill of material on each sheet, including the Charpy V-Notch (CVN) and fracture-critical requirements, if any, for each piece. Indicate fracture-critical areas of members.

- 3.1.6.2.2. **Non-Bridge Members.** Furnish shop drawings for non-bridge members when required by the plans or pertinent items.

- 3.1.7. **Welding Procedure Specifications (WPSs).** Submit WPSs and test reports in accordance with the applicable AWS code to the Construction Division before fabrication begins, and notify the Engineer which procedures will be used for each joint or joint type. Do not begin fabrication until the Engineer approves WPSs.

Post the approved WPSs for the welding being performed on each welding machine, or use another approved method of ensuring the welder has access to the procedure information at all times.

- 3.1.8. **Documentation.** Before beginning fabrication, provide a completed Material Statement Form 1818 (a.k.a. D-9-USA-1) with supporting documentation (such as mill test reports (MTRs)) that the producing mill issues and qualified personnel verifies. Ensure the documentation legibly reflects all information the applicable ASTM specifications require. Supply documents electronically to the Department.

Provide a copy of the shipping or storage invoice, as material is shipped or placed in approved storage that reflects:

- member piece mark identification and calculated weight per piece from the contract drawings,
- number of pieces shipped or in storage,
- total calculated weight for each invoice per bid item, and
- the unique identification number of the shipping or storage invoice.

The inspector's acceptance of material or finished members will not prohibit subsequent rejection if the material or members are found to be damaged or defective. Replace rejected material promptly.

- 3.1.9. **Material Identification.** Assembly-mark individual pieces and issue cutting instructions to the shop using a system that will maintain identity of the original piece.

Identify structural steel by standard and grade of steel. Also differentiate between material toughness requirements (CVN, fracture-critical) as well as any other special physical requirements. In addition, identify structural steel for primary members by mill identification numbers (heat numbers). Use an approved identification system. Use either paint or low-stress stencils to make identification markings on the metal. Mark the material as soon as it enters the shop and carry the markings on all pieces through final fabrication. Transfer the markings before cutting steel for primary members of bridge structures into smaller pieces. Loss of identification marking on any piece, with no other positive identification, or loss of heat number identification on any primary member piece will render the piece unacceptable for use. Unidentifiable material may be approved for use after testing to establish acceptability to the satisfaction of the Engineer. Have an approved testing facility perform testing and a licensed professional engineer sign and seal the results.

3.2. **Welding.**

3.2.1. **Details.**

- 3.2.1.1. **Rolled Edges.** Trim plates with rolled edges used for webs by thermal cutting.

- 3.2.1.2. **Weld Tabs.** Use weld tabs at least 2 in. long for manual and semi-automatic processes, at least 3 in. long for automatic processes, and in all cases at least as long as the thickness of the material being welded. Use longer weld tabs as required for satisfactory work.

- 3.2.1.3. **Weld Termination.** Terminate fillet welds approximately 1/4 in. from the end of the attachment except for galvanized structures and flange-to-web welds, for which the fillet weld must run the full length of the attachment, unless otherwise shown on the plans.

- 3.2.1.4. **No-Paint Areas at Field-Welded Connections.** Keep surfaces within 4 in. of groove welds or within 2 in. of fillet welds free from shop paint.

- 3.2.1.5. **Galvanized Assemblies.** Completely seal all edges of tightly contacting surfaces by welding before galvanizing.

- 3.2.1.6. **Submerged-Arc Welding (SAW).** Do not use hand-held semiautomatic SAW for welding bridge members unless altered to provide automatic guidance or otherwise approved.

- 3.2.1.7. **Tubular Stiffeners for Bridge Members.** Weld in accordance with AWS D1.5, using WPSs qualified based on tests on ASTM A709 Gr. 50W or Gr. 50 steel for non-weathering applications and ASTM A709 Gr. 50W steel for weathering applications.
- 3.2.1.8. **Non-Bridge Member Weathering Steel Welds.** Provide weld metal with atmospheric corrosion resistance and coloring characteristics similar to that of the base metal for weathering steel structures fabricated per AWS D1.1.
- 3.2.2. **Shop Splices.**
- 3.2.2.1. **Shop Splice Locations.** Keep at least 6 in. between shop splices and stiffeners or cross-frames. Obtain approval for shop splices added after shop drawings are approved.
- 3.2.2.2. **Grinding Splice Welds.** Grind shop groove welds in flange plates smooth and flush with the base metal on all surfaces whether the joined parts are of equal or unequal thickness. Grind so the finished grinding marks run in the direction of stress, and keep the metal below the blue brittle range (below 350°F). Groove welds in web plates, except at locations of intersecting welds, need not be ground unless shown on the plans except as required to meet AWS welding code requirements.
- 3.2.3. **Joint Restraint.** Never restrain a joint on both sides when welding.
- 3.2.4. **Stiffener Installation.**
- 3.2.4.1. **Flange Tilt.** Members must meet combined tilt and warpage tolerances before the installation of stiffeners. Cut stiffeners to fit acceptable flange tilt and cupping. Minor jacking or hammering that does not permanently deform the material will be permitted.
- 3.2.4.2. **Stiffeners Near Field Splices.** Tack weld intermediate stiffeners within 12 in. of a welded field splice point in the shop. Weld the stiffeners in the field in accordance with Item 448, "Structural Field Welding," after the splice is made.
- 3.2.5. **Nondestructive Testing (NDT).** Perform magnetic particle testing (MT), radiographic testing (RT), or ultrasonic testing (UT) at the Contractor's expense as specified in D1.5 for bridge structures. The Engineer will periodically witness, examine, verify, and interpret NDT. Additional welds may be designated for NDT on the plans. Retest repaired groove welds per the applicable AWS code after repairs are made and have cooled to ambient temperature. Complete NDT and repairs before assembly of parts into a member, but after any heat-correction of weld distortion.
- 3.2.5.1. **Radiographic Testing.** Radiographs must have a density of at least 2.5 and no more than 3.5, as a radiographer confirms. The density in any single radiograph showing a continuous area of constant thickness must not vary in this area by more than 0.5. Use only ASTM System Class I radiographic film as described in ASTM E1815. Use low-stress stencils to make radiograph location identification marks on the steel.
- 3.2.5.2. **Ultrasonic Testing.** Have UT equipment calibrated yearly by an authorized representative of the equipment manufacturer or by an approved testing laboratory.
- 3.2.5.3. **Magnetic Particle Testing.** Use half-wave rectified DC when using the yoke method unless otherwise approved. Welds may be further evaluated with prod method for detecting centerline cracking.
- 3.2.6. **Testing of Galvanized Weldments.** If problems develop during galvanizing of welded material, the Engineer may require a test of the compatibility of the combined galvanizing and welding procedures in accordance with this Section and may require modification of one or both of the galvanizing and welding procedures.

Prepare a test specimen with a minimum length of 12 in. using the same base material, with the same joint configuration, and using the welding procedure proposed for production work if testing is required. Clean and

galvanize this test specimen using the same conditions and procedure that will be applied to the production galvanizing.

Examine the test specimen after galvanizing. There must be no evidence of excessive buildup of zinc coating over the weld area. Excessive zinc coating buildup will require modification of the galvanizing procedure.

Remove the zinc from the weld area of the test specimen and visually examine the surface. There must be no evidence of loss of weld metal or any deterioration of the base metal due to the galvanizing or welding procedure. Modify the galvanizing or welding procedure as required if there is evidence of deterioration or loss of weld metal, and run a satisfactory retest on the modified procedures before production work. Report procedures and results on the galvanized weldment worksheet provided by the Department.

- 3.3. **Bolt Holes.** Detail holes on shop drawings 1/16 in. larger in diameter than the nominal bolt size shown on the plans unless another hole size is shown on the plans.

Thoroughly clean the contact surfaces of connection parts in accordance with Item 447, "Structural Bolting," before assembling them for hole fabrication. Make holes in primary members full-size (by reaming from a subsize hole, drilling full-size, or punching full-size where permissible) only in assembly unless otherwise approved.

Ream and drill with twist drills guided by mechanical means unless otherwise approved. If subpunching holes, punch them at least 3/16 in. smaller than the nominal bolt size. Submit the proposed procedures for approval to accomplish the work from initial drilling or punching through check assembly when numerically controlled (N/C) equipment is used. Use thermal cutting for holes only with permission of the Engineer. Permission for thermal cutting is not required for making slotted holes, when slotted holes are shown on the plans, by drilling or punching 2 holes and then thermally cutting the straight portion between them. Perform all thermal cutting in accordance with Section 441.3.5.1., "Thermal Cutting."

Slightly conical holes that naturally result from punching operations are acceptable provided they do not exceed the tolerances of S2.1. The tolerance for anchor bolt hole diameter for bridge bearing assemblies is +1/8 in., -0.

- 3.4. **Dimensional Tolerances.** Meet tolerances of the applicable AWS specifications and S2.1 except as modified in this Section.

- 3.4.1. **Rolled Sections.** Use ASTM A6 mill tolerances for rolled sections, except D1.5 camber tolerances apply to rolled sections with a specified camber.

- 3.4.2. **Flange Straightness.** Ensure flanges of completed girders are free of kinks, short bends, and waviness that depart from straightness or the specified camber by more than 1/8 in. in any 10 ft. along the flange. Rolled material must meet this straightness requirement before being laid out or worked. Plates must meet this requirement before assembly into a member. Inspect the surface of the metal for evidence of fracture after straightening a bend or buckle. The Engineer may require nondestructive testing.

- 3.4.3. **Alignment of Deep Webs in Welded Field Connections.** For girders 48 in. deep or deeper, the webs may be slightly restrained while checking compliance with tolerances of S2.1 for lateral alignment at field-welded connections. In the unrestrained condition, webs 48 in. deep or deeper must meet the tolerances of Table 2. Girders under 48 in. deep must meet the alignment tolerances of S2.1.

Table 2
Web Alignment Tolerances for Deep Girders

Web Depth (in.)	Maximum Web Misalignment (in.)
48	1/16
60	1/8
72	1/4
84	5/16
96	5/16
108	3/8
120	7/16
132	7/16
144	1/2

3.4.4. **Bearings.** Correct bearing areas of shoes, beams, and girders using heat, external pressure, or both. Grind or mill only if the actual thickness of the member is not reduced by more than 1/16 in. below the required thickness.

3.4.4.1. **I-Beams, Plate Girders, and Tub Girders.** The plane of the bearing area of beams and girders must be perpendicular to the vertical axis of the member within 1/16 in. in any 24 in.

3.4.4.2. **Closed Box Girders.** Meet these tolerances:

- The plane of the bearing areas of the box girder is perpendicular to the vertical axis of the girder within 1/16 in. across any horizontal dimension of the bearing.
- The planes of the beam supports on the box girder are true to the vertical axis of the supported beams or girders to 1/16 in. in any 24 in.

In the shop, verify the plane of all bearing areas with the box placed on its bearings to field grade, using an approved process for verification.

3.4.4.3. **Shoes.** Meet these tolerances:

- The top bolster has the center 75% of the long dimension (transverse to the girder) true to 1/32 in., with the remainder true to 1/16 in., and is true to 1/32 in. across its entire width in the short dimension (longitudinal to the girder).
- The bottom bolster is true to 1/16 in. across its diagonals.
- For a pin and rocker type expansion shoe, the axis of rotation coincides with the central axis of the pin.
- When the shoe is completely assembled, as the top bolster travels through its full anticipated range, no point in the top bolster plane changes elevation by more than 1/16 in. and the top bolster does not change inclination by more than 1 degree, for the full possible travel.

3.4.4.4. **Beam supports.** Fabricate beam support planes true to the box girder bearing to 1/16 in. in the short direction and true to the vertical axis of the nesting girders to 1/16 in.

3.4.5. **End Connection Angles.** For floor beams and girders with end connection angles, the tolerance for the length back to back of connection angles is $\pm 1/32$ in. Do not reduce the finished thickness of the angles below that shown on the shop drawings if end connections are faced.

3.5. **Other Fabrication Processes.**

3.5.1. **Thermal Cutting.** Use a mechanical guide to obtain a true profile. Hand-cut only where approved. Hand-cutting of radii for beam copes, weld access holes, and width transitions is permitted if acceptable profile and finish are produced by grinding. Provide a surface finish on thermal-cut surfaces, including holes, in accordance with D1.5 requirements for base metal preparation. Obtain approval before using other cutting processes.

- 3.5.2. **Oxygen-Gouging.** Do not oxygen-gouge quenched and tempered (Q&T), normalized, or thermo-mechanically controlled processed (TMCP) steel.
- 3.5.3. **Annealing and Normalizing.** Complete all annealing or normalizing (as defined in ASTM A941) before finished machining, boring, and straightening. Maintain the temperature uniformly throughout the furnace during heating and cooling so the range of temperatures at all points on the member is no more than 100°F.
- 3.5.4. **Machining.** Machine the surfaces of expansion bearings so the travel direction of the tool is in the direction of expansion.
- 3.5.5. **Camber.** Complete cambering in accordance with S2.1 before any heat-curving.
- 3.5.6. **Heat Curving.** Heat-curve in accordance with S2.1. The methods in the AASHTO bridge construction specifications are recommended. Attach cover plates to rolled beams before heat-curving only if the total thickness of one flange and cover plate is less than 2-1/2 in. and the radius of curvature is greater than 1,000 ft. Attach cover plates for other rolled beams only after heat-curving is completed. Locate and attach connection plates, diaphragm stiffeners, and bearing stiffeners after curving, unless girder shrinkage is accounted for.
- 3.5.7. **Bending of Quenched and Tempered Steels.** The cold-bending radius limitations for HPS 70W in S2.1 apply to all Q&T steels.
- 3.6. **Nonconformance Reports (NCRs).** Submit an NCR to the Engineer for approval when the requirements of this Item are not met. Submit NCRs in accordance with the Construction Division's NCR guidelines document. Have readily available access to the services of a licensed professional engineer experienced in steel structures design and fabrication. This licensed professional engineer may be responsible for reviewing potentially structurally deficient members in accordance with the NCR guidelines document. Receive Department approval before beginning repairs. Perform all repair work in strict compliance with the approved NCR and repair procedure.
- 3.7. **Shop Assembly.**
- 3.7.1. **General Shop Assembly.** Shop-assemble field connections of primary members of trusses, arches, continuous beam spans, bents, towers (each face), plate girders, field connections of floor beams and stringers (including for railroad structures), field-bolted diaphragms for curved plate girders and railroad underpasses, and rigid frames. Field-bolted cross-frames and rolled-section diaphragms do not require shop assembly. Complete fabrication, welding (except for shear studs), and field splice preparation before members are removed from shop assembly. Obtain approval for any deviation from this procedure. The Contractor is responsible for accurate geometry.
- Use a method and details of preassembly consistent with the erection procedure shown on the erection plans and camber diagrams. The sequence of assembly may start from any location in the structure and proceed in one or both directions. An approved method of sequential geometry control is required unless the full length of the structure is assembled.
- Verify by shop assembly the fit of all bolted and welded field connections between bent cap girders and plate girders or between plate girders and floor beams.
- Do not measure horizontal curvature and vertical camber for final acceptance until all welding and heating operations are completed and the steel has cooled to a uniform temperature. Check horizontal curvature and vertical camber in a no-load condition.
- 3.7.2. **Bolted Field Connections.** Each shop assembly, including camber, alignment, accuracy of holes, and fit of milled joints, must be approved before the assembly is dismantled.

Assemble with milled ends of compression members in full bearing. Assemble non-bearing connections to the specified gap. Ream all subsize holes to the specified size while the connections are assembled, or drill full size while the connections are assembled. Notify the Engineer before shipping if fill plates or shims are added. Adding or increasing the thickness of shims or fill plates in bearing connections requires approval. Use drift pins and snug-tight bolts during the drilling process to ensure all planes of the connection (webs and flanges) can be assembled simultaneously. Do not use tack welds to secure plates while drilling.

Secure parts not completely bolted in the shop with temporary bolts to prevent damage in shipment and handling. Never use tack welds in place of temporary bolts.

Match-mark connecting parts in field connections using low-stress stencils in accordance with the diagram in the erection drawings.

- 3.7.3. **Welded Field Connections.** Mill or grind bevels for groove welds. Do not cut into the web when cutting the flange bevel adjacent to the web. End preparation, backing, and tolerances for girder splices must be in accordance with Item 448, "Structural Field Welding." Details for all other field-welds must conform to the applicable AWS code unless otherwise shown on the plans.

In the shop, prepare ends of beams or girders to be field-welded taking into account their relative positions in the finished structure due to grade, camber, and curvature. Completely shop-assemble and check each splice. Match-mark the splice while it is assembled with low-stress stencils in accordance with the diagram in the erection drawings.

3.8. **Finish and Painting.**

- 3.8.1. **Shop Painting.** Perform shop painting of bridge members as required in DMS-8104, "Paint, Shop Application for Steel Bridge Members." Grind corners on new steel items to be painted (except for the coatings on box and tub girder interiors) that are sharp or form essentially 90° angles to an approximately 1/16 in. flat surface before blast cleaning. (A corner is the intersection of 2 plane faces.) This requirement does not apply to punched or drilled holes. Do not omit shop paint to preserve original markings.

Ensure painted faying surfaces meet the required slip and creep coefficients for bolted connections as outlined in DMS-8104, "Paint, Shop Application for Steel Bridge Members."

Use a Class A slip (minimum slip coefficient of 0.33) if no slip coefficient or corresponding surface condition is specified. Perform all required testing at no expense to the Department.

Surface preparation and painting the interiors of Tub Girders and Closed Boxes is in accordance with DMS-8104, "Paint, Shop Application for Steel Bridge Members."

- 3.8.2. **Weathering Steel.** Provide an SSPC-SP 6 blast in the shop to all fascia surfaces of unpainted weathering steel beams. Fascia surfaces include:

- exterior sides of outermost webs and undersides of bottom flanges of plate girders and rolled beams,
- all outer surfaces of tub girders and box girders,
- all surfaces of truss members,
- webs and undersides of bottom flanges of plate diaphragms,
- bottom surfaces of floor beams, and
- any other surfaces designated as "fascia" on the plans.

Do not mark fascia surfaces. Use one of the following methods as soon as possible to remove any markings or any other foreign material that adheres to the steel during fabrication and could inhibit the formation of oxide film:

- SSPC-SP 1, "Solvent Cleaning,"
- SSPC-SP 2, "Hand Tool Cleaning,"
- SSPC-SP 3, "Power Tool Cleaning," and

■ SSPC-SP 7, "Brush-off Blast Cleaning."

Do not use acids to remove stains or scales. Feather out touched-up areas over several feet.

- 3.8.3. **Machined Surfaces.** Clean and coat machine-finished surfaces that are in sliding contact, particularly pins and pinholes, with a non-drying, water-repellent grease-type material containing rust-inhibitive compounds. Ensure the coating material contains no ingredients that might damage the steel. Protect machined surfaces from abrasive blasting.
- 3.9. **Handling and Storage of Materials.** Prevent damage when storing or handling girders or other materials. Remove or repair material damaged by handling devices or improper storage by acceptable means in accordance with ASTM A6 and the applicable AWS code.
- Place stored materials on skids or acceptable dunnage above the ground. Keep materials clean. Shore girders and beams to keep them upright and free of standing water. Place support skids close enough to prevent excessive deflection in long members such as columns. Do not stack completed girders or beams at the jobsite.
- Protect structural steel from salt water or other corrosive environments during storage and transit.
- 3.10. **Marking and Shipping.** Mark all structural members in accordance with the erection drawings. If a surface is painted, make the marks over the paint. Do not use impact-applied stencils to mark painted surfaces.
- Mark the weight directly on all members weighing more than 3 tons.
- Keep material clean and free from injury during loading, transportation, unloading, and storage. Pack bolts of each length and diameter, and loose nuts or washers of each size, separately and ship them in boxes, crates, kegs, or barrels. Plainly mark a list and description of the contents on the outside of each package.
- 3.11. **Field Erection.** Do not lift and place any steel member, including girders and diaphragms, over an open highway or other open travel way unless otherwise approved. Do not allow traffic to travel under erected members until sufficiently stable as shown on approved erection drawings.
- 3.11.1. **Pre-Erection Conference.** Schedule and attend a pre-erection conference with the Engineer at least 7 days before commencing steel erection operations. Do not install falsework or perform any erection operations before the meeting.
- 3.11.2. **Methods and Equipment.** Do not tack-weld parts instead of using erection bolts. Do not tack-weld parts to hold them in place for bolting. Provide falsework, tools, machinery, and appliances, including drift pins and erection bolts. Provide enough drift pins, 1/32 in. larger than the connection bolts, to fill at least 1/4 of the bolt holes for primary connections. Use erection bolts of the same diameter as the connection bolts.
- Securely tie, brace, or shore steel beams or girders immediately after erection as shown on the erection drawings. Maintain bracing or shoring until the diaphragms are in place and as specified in the erection drawings. Protect railroad, roadway, and marine traffic underneath previously erected girders or beams from falling objects associated with other construction activities.
- Only welders certified or working directly under the supervision of a foreman certified in accordance with Item 448, "Structural Field Welding," may handle torches when applying heat to permanent structural steel members.
- 3.11.3. **Falsework.** Construct falsework in accordance with the erection plan. Construct foundations for shore towers as shown on erection drawings. Do not use timber mats with deteriorated timbers or soil to construct shore tower foundations. Notify the Engineer of completed falsework to obtain approval before opening roadway to traffic or starting girder erection activities. Ensure falsework is protected from potential vehicle impact.

Inspect and maintain falsework daily. Use screw jacks or other approved methods to control vertical adjustment of falsework to minimize the use of shims.

3.11.4. **Handling and Assembly.** Accurately assemble all parts as shown on the plans and the approved shop drawings. Verify match-marks. Handle parts carefully to prevent bending or other damage. Do not hammer if doing so damages or distorts members. Do not weld any member for transportation or erection unless noted on the plans or approved by the Engineer.

3.11.4.1. **Welded Connections.** Weld flange splices to 50% of their thickness and meet the minimum erection bracing and support requirements before releasing the erection cranes, as shown on the plans and on the approved erection plans. Field-weld in accordance with Item 448, "Structural Field Welding."

3.11.4.2. **Bolted Connections.** Before releasing the erection cranes:

- install 50% of the bolts in the top and bottom flanges and the web with all nuts finger-tight,
- meet the minimum erection bracing and support requirements shown on the plans and on the approved erection plans, and
- install top lateral bracing across the connection for tub girders, and fully tension the bolts connecting the bracing to the top flanges.

Install high-strength bolts, including erection bolts, in accordance with Item 447, "Structural Bolting." Clean bearing and faying surfaces for bolted connections in accordance with Item 447, "Structural Bolting." Clean the areas of the outside ply under washers, nuts, and bolt heads before bolt installation. Ensure the required faying surface condition is present at the time of bolting.

3.11.5. **Misfits.** Correct minor misfits. Ream no more than 10% of the holes in a plate connection (flange or web), and ensure no single hole is more than 1/8 in. larger than the nominal bolt diameter. Submit proposed correction methods for members with defects that exceed these limits or prevent the proper assembly of parts. Straighten structural members in accordance with S2.1. Make all corrections in the presence of the Engineer at no expense to the Department. Do not remove and reweld gusset plates without approval.

3.11.6. **Bearing and Anchorage Devices.** Place all bearing devices such as elastomeric pads, castings, bearing plates, or shoes on properly finished bearing areas with full and even bearing on the concrete. Place metallic bearing devices on 1/4 in.-thick preformed fabric pads manufactured in accordance with DMS-6160, "Water Stops, Nylon-Reinforced Neoprene Sheet, and Elastomeric Pads," to the dimensions shown on the plans. Provide holes in the pad that are no more than 1/4 in. larger than the bolt diameter.

Build the concrete bearing area up to the correct elevation once it has been placed below grade using mortar that meets Item 420, "Concrete Substructures," and provide adequate curing. Use only mortar for build-ups between 1/8 in. and 3/8 in. thick. Use galvanized steel shims or other approved shim materials in conjunction with mortar if the bearing area must be raised more than 3/8 in.

Provide at least 75% contact of flange to shoe with no separation greater than 1/32 in. for beams and girders. Make corrections using heat or pressure in accordance with S2.1, or with galvanized shims. Correct small irregularities by grinding.

Provide at least 85% contact between the rocker plate and the base plate. Adjust the location of slotted holes in expansion bearings for the prevailing temperature. Adjust the nuts on the anchor bolts at the expansion ends of spans to permit free movement of the span. Provide lock nuts or burr the threads.

Remove all foreign matter from sliding or machine-finished surfaces before placing them in the structure.

Restore distorted bearing pads or expansion bearings to an equivalent 70°F position after completion of all welded or bolted splices, using an approved method of relieving the load on the bearing devices.

3.11.7. **Erecting Forms.** Do not erect forms until all welding or bolting is complete and the unit is positioned and properly set on the bearings unless otherwise noted on the plans.

- 3.11.8. **Field Finish.** Paint in accordance with Item 446, "Field Cleaning and Painting Steel." Restore weathering steel that will remain unpainted to a uniform appearance by solvent cleaning, hand cleaning, power brush, or blast cleaning after all welding and slab concrete placement has been completed. Remove from all unpainted weathering steel fascia surfaces (see Section 441.3.8.2., "Weathering Steel,") any foreign material, including markings, that adheres to the steel and could inhibit formation of oxide film as soon as possible. Feather out touched-up areas over several feet. Do not use acids to remove stains or scales.

4. MEASUREMENT AND PAYMENT

The work performed, materials furnished, equipment, labor, tools, and incidentals will not be measured or paid for directly but will be subsidiary to pertinent Items.

Item 442

Metal for Structures



1. DESCRIPTION

Provide structural steel, high-strength bolts, forgings, steel castings, iron castings, wrought iron, steel pipe and tubing, aluminum castings and tubing, or other metals used in structures, except reinforcing steel and metal culvert pipe.

2. MATERIALS

Furnish mill test reports (MTRs), supplemental test documentation, and certifications required by this and other pertinent Items.

2.1. **Structural Steel.** The Engineer may sample and test steel in accordance with ASTM A370.

2.1.1. **Bridge Structures.** Provide the grade of ASTM A709 steel shown on the plans. Grade 50W, 50S, or HPS 50W may be substituted for Grade 50 at no additional cost to the Department. Use Zone 1 if no AASHTO temperature zone is shown on the plans.

2.1.2. **Non-Bridge Structures.**

2.1.2.1. **Steel Classifications.** Provide the types and grades of steel listed in this Section unless otherwise shown on the plans.

2.1.2.1.1. **Carbon Steel.** Meet ASTM A36.

2.1.2.1.2. **Low-Alloy Steel.** Meet the requirements of one of the following standards:

- ASTM A529 Grade 50;
- ASTM A572 Grade 50 or 55;
- ASTM A588;
- ASTM A709 Grade 50, 50S, 50W, or HPS 50W; or
- ASTM A992.

Specify ASTM A6 supplemental requirement S18, "Maximum Tensile Strength," for material used for sign, signal, and luminaire supports.

2.1.2.2. **Impact Testing.** Tension members and components of the following structure types, if more than 1/2 in. thick. Other members designated on the plans must meet the Charpy V-notch (CVN) requirements of Table 1:

- base plates for roadway illumination assemblies, traffic signal pole assemblies, high mast illumination poles, camera poles, and overhead sign supports;
- pole mounting plates, arm mounting plates, and clamp-on plates for traffic signal pole assemblies;
- arm stiffeners, pole gussets, and stiffeners for traffic signal pole long mast arm assemblies (50 ft. to 65 ft.);
- pole shafts, ground sleeves, and handhole frames for high mast illumination poles;
- W-columns, tower pipes, multiple-sided shafts, tower pipe and multiple-sided shaft connection plates, chord angles, chord splice plates or angles, and truss bearing angles for truss type overhead sign supports; and

- pipe posts, pipe arms, post and arm flange plates, and handhole frames for monotube overhead sign supports.

Table 1
CVN Requirements for Non-Bridge Steel

Material	Thickness	Minimum CVN Toughness
ASTM A36, A53, A242, A500, A501, A709 Gr. 36, any other steel with minimum specified yield point below 40 ksi	up to 4"	15 ft.-lb. at 70°F
ASTM A572, ¹ A588, ¹ A633, ¹ any other steel with minimum specified yield point between 40 and 65 ksi, inclusive	up to 2"	15 ft.-lb. at 70°F
	over 2" to 4", mechanically fastened	15 ft.-lb. at 70°F
	over 2" to 4", welded	20 ft.-lb. at 70°F
Any steel with minimum specified yield point over 65 ksi and under 90 ksi ²	up to 2-1/2"	20 ft.-lb. at 50°F
	over 2-1/2" to 4", mechanically fastened	20 ft.-lb. at 50°F
	over 2-1/2" to 4", welded	25 ft.-lb. at 50°F

1. Reduce the testing temperature by 15°F for each 10-ksi increment or fraction thereof above 65 ksi if the yield point of the material given on the MTR exceeds 65 ksi.
2. Reduce the testing temperature by 15°F for each 10-ksi increment or fraction thereof above 85 ksi if the yield point of the material given on the MTR exceeds 85 ksi.

Use the (H) frequency of testing for material with minimum specified yield point up to 50 ksi. Use the (P) frequency of testing for material with minimum specified yield point over 50 ksi. Ensure steel is sampled and tested in accordance with ASTM A673.

2.1.3. Other Components.

2.1.3.1. **Miscellaneous Bridge Components.** Provide steel that meets ASTM A36, A709 Grade 36, or A500 Grade B for members such as steel bearing components not bid under other Items, steel diaphragms for use with concrete bridges, and armor and finger joints, unless otherwise shown on the plans.

2.1.3.2. **Shear Connectors and Anchors.** Provide cold-drawn bars for stud shear connectors, slab anchors, and anchors on armor and finger joints that meet the requirements of ASTM A108, Grade 1010, 1015, 1018, or 1020, either semi-killed or killed, and have the tensile properties given in Table 2 after drawing or finishing. Determine tensile properties in accordance with ASTM A370.

Table 2
Minimum Tensile Properties for Bar Stock

Tensile strength	60 ksi
Yield strength	50 ksi
Elongation	20% (2")
Reduction of area	50%

Provide certification from the manufacturer that the studs or anchors as delivered have the required material properties.

2.1.3.3. **Fasteners.** Provide high-strength bolts that meet ASTM A325 or A490 as shown on the plans. The Department may sample high-strength bolts, nuts, and washers for structural connections in accordance with Tex-719-I.

Follow the requirements of Item 447, "Structural Bolting," for tests, test reports, and supplemental requirements for high-strength bolts, nuts, and washers.

Use bolts that meet ASTM A307 and nuts that meet ASTM A563 when ASTM A325 or A490 bolts are not shown on the plans.

2.1.3.4. **Slip-Resistant Deck Plates.** Furnish steel for deck plates that meets ASTM A786 and one of A242, A588, or A709 Gr. 50W. State the type and trade name of material to be used on the shop drawings.

- 2.1.3.5. **Rail Posts.** Provide material for rail posts that meets ASTM A36 or ASTM A709 Grade 36 unless otherwise shown on the plans.
- 2.2. **Steel Forgings.** Provide steel forgings for pins, rollers, trunnions, or other forged parts that meet ASTM A668, Class C, D, F, or G, as shown on the plans. For pins 4 in. or smaller in diameter for non-railroad structures, material that meets ASTM A108, Grades 1016 to 1030, with a minimum yield strength of 36 ksi, may be used instead.
- 2.3. **Steel Castings.** Provide steel castings that meet ASTM A27, Grade 70-36.
- 2.4. **Iron Castings.** Provide iron castings that are true to pattern in form and dimensions; free from pouring faults, sponginess, cracks, blow holes, and other defects in positions affecting their strength and value for the service intended; and meet the standards shown in Table 3.

Table 3
Standards for Iron Castings

Casting Material	ASTM Standard	Grade or Class
Gray iron	A48	35B
Malleable iron	A47	32510
Ductile iron	A536	70-50-05

- 2.5. **Steel Tubing.** Provide steel tubing that meets ASTM A500, Grade B unless otherwise shown on the plans. Tubing that meets API Standard 5L, Grade X52 may be used if produced by a mill listed in the standard API specifications as authorized to produce pipe with the API monogram. Hydrostatic tests are not required for API 5L steel, and instead of an MTR, the manufacturer may furnish a certificate for each lot or shipment certifying the tubing meets the requirements of this Section.
- 2.6. **Pipe Rail.** "Pipe" includes special extruded and bent shapes. Provide pipe that is rolled, extruded, or cold-pressed from a round pipe or flat plate, and of the section shown on the plans.
- Ensure the design of the cold press and dies results in a pipe of uniform section-free from die marks. Cut the pipe to the lengths required once it has been formed to the required section. Make the end cuts and notches at the angles to the axis of the pipe required to produce vertical end faces and plumb posts when required by the plans. Provide a neat and workmanlike finish when cutting and notching pipe.
- 2.7. **Aluminum.** Provide aluminum materials that meet the standards shown in Table 4 unless otherwise shown on the plans.

Table 4
Aluminum Standards

Material	ASTM Standard	Alloy-Temper
Castings	B108	A444.0-T4
Extrusions	B221	6061-T6
Sheet or plate	B209	6061-T6

When testing is required, cut test specimens from castings from the lower 14 in. of the tension flange, but not at the junction of the rib or base. Flatten the curved surfaces before machining. Provide standard test specimens in conformance with ASTM E8.

3. CONSTRUCTION

- 3.1. **Fabrication, Erection, and Painting.** Fabricate, weld, and erect structural metal in accordance with Item 441, "Steel Structures," Item 447, "Structural Bolting," Item 448, "Structural Field Welding," and the applicable AWS welding code. Paint in accordance with Item 446, "Field Cleaning and Painting Steel." Aluminum or galvanized steel members do not require painting unless otherwise shown on the plans.
- 3.2. **Galvanizing.** Galvanize fabricated steel items, steel castings, bolts, nuts, screws, washers, and other miscellaneous hardware in accordance with Item 445, "Galvanizing." Galvanizing is not required unless specified.

4. MEASUREMENT

This Item will be measured by the pound of structural metal furnished and placed in a complete structure not including the weight of erection bolts, paint, or weld metal.

This is a plans quantity measurement Item. The quantity to be paid is the quantity shown in the proposal unless modified by Article 9.2., "Plans Quantity Measurement." Additional measurements or calculations will be made if adjustments of quantities are required.

The maximum percent variance from the plans quantity will be as given in Table 5.

Table 5
Percent Variance

Quantity	Variance
Over 1,000,000 lb.	1/2%
100,000 through 1,000,000 lb.	1%
Under 100,000 lb.	1-1/2%

If the requests for increases in sizes or weights of members are approved, measurement will be made on the sizes or weights shown on the plans.

Castings, bearing plates, anchor bolts, drains, deck plates, armor and finger joints, and other metal for which no separate measurement is specified will be included in the total quantity of structural steel.

The weights of rolled materials (such as structural shapes and plate) will be computed on the basis of nominal weights and dimensions using measurements shown on the plans. Deductions will not be made for material that is removed for copes, clips, planing, or weld preparation. The weight of castings will be computed from the dimensions shown on the approved shop drawings. Shoes will be measured by the weights shown on the plans.

Weight of high-strength fasteners will be based on Table 6. Weight of other metal will be based on Table 7.

Splices will be measured as follows:

- No additional weight will be allowed for weld metal in a welded splice.
- Where a bolted splice is permitted as an alternate for a welded splice, measurement will be made on the basis of a welded splice.
- Where a bolted splice is required, the weight of the splice material, bolt heads, washers, and nuts will be measured with no deduction for holes.

Table 6
Pay Weight for High-Strength Fasteners, Pounds per Hundred Units

Diameter	Item		
	Bolt heads	Nuts	Washers
3/4"	15	19	4.8
7/8"	23	30	7.0
1"	32	43	9.4
1-1/8"	45	59	11
1-1/4"	64	79	14

Table 7
Pay Weight for Metals

Material	Weight (lb./cu. in.)
Steel	0.2836
Cast iron	0.2604
Wrought iron	0.2777

5. PAYMENT

The work performed and materials furnished in accordance with this Item and measured as provided under "Measurement" will be paid for at the unit price bid for "Structural Steel" of the type (Rolled Beam, Plate Girder, Tub Girder, Box Girder, Railroad Through-Girder, Railroad Deck-Girder, Miscellaneous Bridge, Miscellaneous Non-Bridge) specified. This price is full compensation for materials, fabrication, transportation, erection, paint, painting, galvanizing, equipment, tools, labor, and incidentals.

Item 445

Galvanizing



1. DESCRIPTION

Galvanize or repair galvanizing on metal items.

2. MATERIALS

Provide galvanized metal items that meet the standards in Table 1.

Table 1
Galvanizing Standards

Item	Standard
Fabricated items, rolled, pressed, or forged steel shapes, plates, pipes, tubular items, and bars	ASTM A123
Steel or iron castings	ASTM A153, Class A
Bolts, nuts, screws, washers, and other miscellaneous hardware	ASTM A153, Class C or D or ASTM B695, Class 50
Miscellaneous fasteners	ASTM B633, Class Fe/Zn 8
Rail elements for metal beam guard fence or bridge railing	AASHTO M 180
Permanent metal deck forms, supporting angles, and incidental items	ASTM A653, Coating Designation G165

3. CONSTRUCTION

- 3.1. **General.** Provide for proper filling, venting, and draining during cleaning and galvanizing if fabricated members or assemblies are required to be hot-dip galvanized. Provide drain holes or slots as required, except where prohibited by the plans. Provide a surface finish on the thermal-cut drain holes or slots in accordance with AWS D1.1 requirements for base metal preparation. Drain to the small end of tapered sections that are assembled using slip-joint splices. Ensure cleaning and galvanizing does not produce hydrogen embrittlement.

Remove weld flux, weld slag, and any other weld residue or impurities before galvanizing. Before galvanizing material 1/4 in. or greater in thickness:

- remove all sharp burrs, and
- chamfer to approximately 1/16 in. all edges.

- 3.2. **Painting Galvanized Materials.** Provide a paint system if painting is specified on galvanized materials in accordance with DMS-8102 "Paint Systems for Galvanized Steel." Follow all manufacturer instructions for surface preparation and application including the following:

- 3.2.1. **Surface Preparation.** Do not water-quench or chromate-quench galvanized surfaces to be painted. Prepare the surface in accordance with ASTM D6386. Apply coating within 12 hr. of cleaning. Re-clean the surface if more than 12 hr. elapse before initial painting.

- 3.2.2. **Coating Application.** Ensure the coating is smooth, even, continuous, and free of drips, runs, sags, holidays, wrinkles, or other coating defects. Ensure the coating has a uniform appearance within all portions of the painted piece and all related pieces and components of a project. Ensure all repairs are smooth, even, and visually match the remainder of the coated piece by use of feathering and other appropriate techniques to avoid sharp transitions.

- 3.3. **Galvanizing Weldments.** If problems develop during galvanizing of welded material, the Engineer may require a compatibility test of the combined galvanizing and welding procedures in accordance with Section 441.3.2.6., "Testing of Galvanized Weldments," and may require modification of one or both of the galvanizing and welding procedures.
- 3.4. **Workmanship.**
- 3.4.1. **Coverage.** Bare spots no more than 1/8 in. across are acceptable unless numerous. Repair larger bare spots in accordance with Section 445.3.5., "Repairs." Local runs or drips of zinc coating are acceptable unless they interfere with the intended use of the product. Carefully remove plainly visible excessive zinc accumulations.
- 3.4.2. **Adhesion.** Tap the coated area with a small hammer to test coating adhesion. The coating is acceptable if it is not brittle and does not scale or flake.
- 3.4.3. **Appearance.**
- 3.4.3.1. **White Rust.** A white powdery residue indicates moisture. Remove heavy layers of white rust that have caused the coating to pit. Light coatings may remain unless the Engineer requires chemical removal. Remove white rust from articles that will be in direct contact with soil.
- 3.4.3.2. **Red Rust.** Red rust on galvanized items indicates uncoated areas. See Section 445.3.4.1., "Coverage," for acceptance criteria.
- 3.4.3.3. **Alligator Cracking or Spider Webbing.** The composition of the base metal may cause dark lines resembling alligator skin. See Section 445.3.4.2., "Adhesion," to determine whether the coating is acceptable.
- 3.4.3.4. **Dull Gray Coating.** The composition of the base metal can cause a dull gray color. See Section 445.3.4.2., "Adhesion," to determine whether the coating is acceptable.
- 3.4.4. **Coating Thickness.** Galvanize to the thickness specified. Use Tex-728-I to determine coating thickness.
- 3.5. **Repairs.** Use zinc-based solders, sprayed zinc, or zinc-rich paints for repairs in accordance with this Section.
- 3.5.1. **Materials.**
- 3.5.1.1. **Zinc-Based Solders.** Solders used in rod form or as powders:
 - zinc-tin-lead alloys with liquidus temperatures in the range of 446°F to 500°F or
 - zinc-cadmium alloys with liquidus temperatures in the range of 518°F to 527°F.
- 3.5.1.2. **Sprayed Zinc (Metallizing).** Zinc coating applied by spraying with droplets of molten metal using wire, ribbon, or powder processes.
- 3.5.1.3. **Organic Zinc-Rich Paints.** Zinc-rich paints based on organic binders that meet the requirements of DMS-8103, "Galvanizing Repair Paints." The Department's MPL has a list of approved repair paints for galvanized coatings.
- 3.5.2. **Repair Processes.**
- 3.5.2.1. **Zinc-Based Solders.** Remove moisture, oil, grease, dirt, corrosion products, and welding slag or flux from surfaces to be repaired. Clean surface to white metal by wire-brushing, light grinding, or mild blasting extending into the surrounding undamaged galvanized coating. Preheat cleaned areas to at least 600°F, but not more than 750°F. Wire-brush while heating and evenly distribute a layer of zinc solder. Flush the repaired area with water or wipe with a damp cloth to remove flux residue when repair is completed.

- 3.5.2.2. **Sprayed Zinc (Metallizing).** Remove oil, grease, corrosion products, and any welding slag or flux from surfaces to be repaired, and ensure the surfaces are dry. Clean surface to white metal by wire-brushing, light grinding, or mild blasting extending into the surrounding undamaged galvanized coating. Apply coating by metal-spraying pistols fed with either zinc wire, ribbon, or powder. Provide a coating that is uniform and free of lumps, coarse areas, or loose particles.
- 3.5.2.3. **Organic Zinc-Rich Paints.** Remove oil, grease, corrosion products, and welding slag or flux from surfaces to be repaired, and ensure the surfaces are clean and dry. Clean surface to near-white metal by wire-brushing, light grinding, or mild blasting extending into the surrounding undamaged coating to provide a smooth repair. Spray or brush-apply the paint to the prepared area in accordance with the paint manufacturer's instructions to attain the required dry-film thickness. Provide multiple passes when using spray application.
- 3.6. **Repair Coating Thickness.** Measure thickness in the repaired area using Tex-728-I after completing repair and cooling or curing. The minimum thickness required is the same as that required for the specified galvanizing. However, if the repair uses zinc-rich paints, the minimum coating thickness is 50% higher than the specified galvanizing thickness but not greater than 4.0 mils.

4. MEASUREMENT AND PAYMENT

The work performed, materials furnished, equipment, labor, tools, and incidentals will not be measured or paid for directly but will be considered subsidiary to pertinent Items.

Item 446

Field Cleaning and Painting Steel



1. DESCRIPTION

Prepare steel surfaces for painting and apply paint.

2. MATERIALS

Provide the paint system (surface preparation, primer, intermediate, and appearance coats as required) shown on the plans. Provide System II if no system specified. Provide a concrete gray appearance coat (Federal Standard 595C, color 35630,) unless otherwise shown on the plans. Use differing colors for each individual coat with enough contrast between colors to distinguish the various steps in the painting process, including differing the color of the stripe coat relative to the primer and intermediate coat.

- 2.1. **Paint Systems.** Standard paint systems for painting new and existing steel include the following:
- 2.1.1. **System I-A (Overcoating, One Coat).** Provide an overcoating system in accordance with DMS-8105, "Paint, One Coat Overcoat," and the manufacturer's specifications.
- 2.1.2. **System I-B (Overcoating, High Corrosion Environment).** Provide paint in accordance with DMS-8101, "Structural Steel Paints—Performance." Provide a penetrating sealer, intermediate prime coat on bare steel areas, and an appearance coat in accordance with manufacturer's specifications.
- 2.1.3. **System II.** Provide #810 Prime Coat meeting DMS-8100, "Structural Steel Paints—Formula," and acrylic latex appearance coat meeting DMS-8101, "Structural Steel Paints—Performance."
- 2.1.4. **System III-A.** Provide paint in accordance with DMS-8101, "Structural Steel Paints—Performance." Provide organic zinc (OZ) prime coat, epoxy intermediate stripe coat, epoxy intermediate full coat and urethane appearance coat.
- 2.1.5. **System III-B.** Provide paint in accordance with DMS-8101, "Structural Steel Paints—Performance." Provide inorganic zinc (IOZ) prime coat, epoxy intermediate, and urethane appearance coat. Provide epoxy zinc prime coat, as recommended by the IOZ manufacturer, for touchup of IOZ.
- 2.1.6. **System IV.** Provide paint in accordance with DMS-8101, "Structural Steel Paints—Performance." Provide IOZ prime coat and acrylic latex appearance coat. Provide epoxy zinc prime coat, as recommended by the IOZ manufacturer, for touchup of IOZ.
- 2.2. **Paint Inside Tub Girders and Closed Boxes.** In accordance with Item 441, "Steel Structures."
- 2.3. **Paint over Galvanizing.** In accordance with Item 445, "Galvanizing."
- 2.4. **Special Protection System.** Provide the type of paint system shown on the plans or in special provisions to this Item. Special Protection System paints must have completed NTPEP Structural Steel Coatings (SSC) testing regimen as a complete system, with full data available through NTPEP unless specified otherwise.

3. EQUIPMENT

Ensure spray equipment:

- has adequate capacity and sufficient gauges, filters, agitators, regulators, and moisture separators to ensure delivery of clean dry air at the proper pressure and volume;
- is adequate for the type of paint being used;
- has spray heads that provide a smooth, uniform coat of paint;
- will remove moisture from air stream in contact with the paint; and
- has no dried coatings, solvents, or other foreign matter on surfaces that paint is likely to contact.

Maintain all equipment and accessories in good working order.

Keep paint pots no more than 20 ft. above or below the level of spray application of paint during painting operations. Do not allow fluid hoses to sag more than 10 ft. below the level of the bottom of the paint pot or actual spraying operations, whichever is the lowest point. Keep hoses serviceable with no cracks or deterioration. Equip paint pots (or other containers from which the paint is dispensed) with agitators that operate whenever paint is in the pot.

- 3.1. **Airless Spray Equipment.** Use regulator and air or fluid pressure gauges. Use fluid hoses with at least 1/4-in. inside diameter (I.D.) and a maximum length of 75 ft.
- 3.2. **Conventional Spray Equipment.** Use independent fluid pressure and atomization pressure regulators and gauges. Use fluid and air hoses with at least 1/2-in. I.D. and a maximum length of 75 ft.

4. CONSTRUCTION

- 4.1. **Qualification.** Certification of the cleaning and painting contractor, subcontractor, or fabricator is required as follows:

Submit to the Engineer documentation verifying SSPC QP 1 certification for work requiring the removal or application of coatings. Additionally, submit to the Engineer documentation verifying SSPC QP 2 Cat A certification when work requires removal of coatings containing hazardous materials. Maintain certifications throughout the project. No work may be performed without current and active certifications unless otherwise shown on the plans. The Engineer may waive QP 1 certification for minor, touch-up repair work and coating steel members repaired in accordance with Item 784, "Steel Member Repair."

The Engineer may waive certification requirements, when stated on the plans, for the purpose of qualification in the SSPC QP program if the SSPC has accepted the project as a qualification project as part of the process for obtaining SSPC QP1 or QP2 Cat A certification. Submit SSPC QP applications and proof of acceptance before beginning work or provide SSPC QP 7 certification when required on the plans.

Inform the Engineer within 1 business day of all scheduled or unannounced inspections or audits by SSPC, OSHA, EPA, TCEQ, or other agencies or organizations. Furnish the Engineer a complete copy of all inspection and audit reports and any SSPC DAC actions within 7 days of receipt.

- 4.2. **Responsibility for Hazards.** Comply with Section 6.10., "Hazardous Materials." Handle all paints and cleaning products in accordance with the information provided by the manufacturer and all applicable federal and state regulations.

- 4.3. **Access.** Provide safe access to all parts of the work for proper inspection. Do not place rigging, scaffolds, etc., in contact with previously painted surfaces until the previously applied coating has fully cured. Protect previously painted and cured surfaces with an approved padding to minimize damage when rigging, scaffolds, etc., will be placed on or hung from those surfaces. Avoid and minimize coating damage to the extent possible. Repair all coating damaged as a result of rigging or scaffolding as directed.
- Remove tree limbs, bushes, grass, and other items that will interfere with the cleaning and painting operations as directed. Remove vertical clearance signs, and erect and maintain temporary ground-mounted signs matching the content and letter size on the existing sign unless otherwise directed. Re-attach permanent clearance signs as directed.
- 4.4. **Steel to be Painted.** Clean and paint all structural steel except weathering steel that is to remain unpainted, unless otherwise shown on the plans. Structural steel includes all main members, bearing apparatus, diaphragms, floor beams, rivets, bolts, lateral bracing, etc., where applicable. Paint the rolling faces of rockers and base plates, all surfaces of bearing plates, and all surfaces of iron or steel castings, whether or not the surfaces are milled unless otherwise shown on the plans or exempted in this Item. Perform the initial cleaning and application of required prime and intermediate coatings on new steel before shipment of the steel to the jobsite unless otherwise provided in the Contract or approved in writing.
- 4.5. **Special Protection System.** Apply paint as shown on the plans.
- 4.6. **Cleaning and Painting New Steel.** Clean and prime new steel in accordance with Item 441, "Steel Structures," before erection or installation of repair pieces. Clean and paint unpainted areas of newly erected steel, including bolts, nuts, washers, and areas where the shop-applied paint has been damaged or fails to meet specification requirements, in accordance with the method required under the paint system specified and Section 446.4.7.3.1., "General Preparation." Water blast exposed surfaces of all newly erected steel. Provide Tool Cleaning surface preparation to all repair areas. Prepare all unpainted areas with Abrasive Blast Cleaning. Repair primer coat and apply remaining coats after erection and maintenance work is complete. Prevent paint and overspray from coming in contact with passing traffic, private and public property, and areas of the bridge not designated to be painted.
- 4.7. **Cleaning and Painting Existing Steel.**
- 4.7.1. **Hold Points.** No work may proceed beyond the listed hold point until the Engineer has reviewed and given provisional approval. Provide the following hold points at a minimum:
- at containment completion,
 - following any surface preparation,
 - immediately before each coating application,
 - after coating application,
 - after each coat has cured, and
 - after preparation of areas for repair.
- 4.7.2. **Containment.** Submit a plan that details the procedures and type and size of equipment proposed to keep public property, private property, and the environment from being adversely affected by the cleaning and painting operations. Approval of the plan is required before cleaning and painting operations begin. Containment is not required for painting newly erected, shop primed steel other than to comply with Section 446.4.6., "Cleaning and Painting New Steel."
- When required on the plans, submit a containment plan and engineering analysis showing the loads, including wind loads, added to the existing structure by the containment system and waste materials. Verify the forces and stresses induced in the members from these loads do not result in overstress of the members. Have a licensed professional engineer sign, seal, and date the submittal.
- Provide containment during all cleaning and painting operations of existing steel structures. Obtain approval of the constructed containment system before beginning cleaning and painting.

Unless otherwise shown on the plans, construct and maintain a structure meeting the following minimum requirements:

- SSPC Guide 6, Class 1A, Level 1 Emissions;
- ability to withstand winds up to 30 mph;
- enclosure of all sides of area with air-impenetrable walls;
- illumination meeting SSPC Guide 12;
- rigid, watertight floor formed from minimum 20 gauge steel;
- overlapping seams and entryways; and
- exhaust air filtration system capable of creating negative pressure inside the enclosure causing the sides of the containment to have a concave appearance and demonstrating minimum 100 ft. per minute cross draft air flow and minimum 50 ft. per minute downdraft air flow in all areas within the containment.

In place of a full containment structure, a modified containment system may be proposed for the following situations:

- when using abrasive blasting equipment equipped with negative pressure able to contain all blast refuse. Demonstrate, for approval, the equipment's ability to contain all blast refuse.
- when using hand tools for spot cleaning only, provide a system that will contain all removed paint, rust, and other debris. Place an airtight membrane below the member being cleaned to collect all falling debris.
- when using power hand tools for spot cleaning only that are equipped with high-efficiency particulate air (HEPA) filter vacuums that will capture all removed paint, rust, and other debris. Otherwise, provide an airtight membrane below the member being cleaned to collect all falling debris.

Provide a system meeting SSPC Guide 6, Class 1W, when using water blasting.

Store, characterize, and dispose of all recovered debris in accordance with 30 TAC 335, "Industrial Solid Waste and Municipal Hazardous Waste." Alternatively, Universal Waste rules may be used. Discharge liquids in accordance with the TCEQ Texas Pollution Discharge Elimination Program (30 TAC 305, "Effluent Guidelines and Standards for TPDES Permits") and Texas Surface Water Quality Standards (30 TAC 307). Alternatively, liquids may be captured, stored, and characterized for disposal at an authorized facility in accordance with 30 TAC 315, "Pretreatment Regulation for Existing and New Sources of Pollution," or 30 TAC 335, "Industrial Solid Waste and Municipal Hazardous Waste."

Use a skimmer when cleaning and painting over bodies of water. Remove any blast or paint material the skimmer collects the day the release occurs. Correct the containment problem that allowed the release before continuing work.

Ensure air is clear of dust and remove all blast refuse from cleaned members before the inspector enters the containment to inspect the cleaned surfaces. Remove all blast refuse from the containment before ending work for the day.

4.7.3. **Preparation of Surfaces.** Prepare surfaces before applying paint.

4.7.3.1. **General Preparation.** Clean far enough into any shop-applied paint to ensure removal of all contaminants. Feather edges of sound paint around cleaned areas.

Ensure all surfaces to be painted are completely free of oil, grease, moisture, dirt, sand, overspray, welding contamination (slag or acid residue); loose or flaking mill scale, rust, or paint; weld spatter; and any other conditions that will prevent the paint from forming a continuous, uniform, tightly adhering film. Remove all hackles, splinters weld spatter, sharp edges, fins, slag, or other irregularities which may interfere with proper paint adhesion to the steel. Remove all steel splinters (hackles) raised or evident during cleaning. Reblast areas from which hackles are removed when abrasive blast cleaning is required.

Before other cleaning operations, remove grease-like contaminants with clean petroleum solvents or other approved methods. Contain solvents and removed material as approved. Dispose of properly or reuse solvents as approved. This requirement applies to all coats.

When abrasive blast cleaning is required, blast all flame-cut edges to produce a visible anchor pattern over the entire flame-cut surface.

Completely remove, as directed, the protective coating on machined surfaces and pins.

Do not damage adjacent materials such as concrete during surface preparation or painting.

Feather all sound, tightly adhered coating edges surrounding cleaned or repaired areas a minimum of 1 in. and ensure a smooth, blended transition.

Round all corners and edges to a 1/16-in. radius. Reblast as needed. Remove pack rust to depth of at least 0.5 in.

- 4.7.3.2. **Classes of Cleaning.** The requirements of Section 446.4.7.3.1., "General Preparation," apply whether or not a class of cleaning is specified. Use an approved abrasive for abrasive blasting. Do not use steel shot. Use an abrasive recycling system with an approved recyclable abrasive when abrasive blast cleaning is used to remove existing paint containing lead or chromium. Abrasive will be considered recyclable if it is separated from the dust and paint debris before being reused. All abrasives must meet SSPC-AB1, AB2, or AB3 as appropriate.

All paint systems require water blasting to remove contaminants before any other surface preparation. Both System I-A and I-B require tool cleaning for defective areas of disbanded coating or rust. All other paint systems require abrasive blast cleaning unless otherwise shown on the plans.

- 4.7.3.2.1. **Abrasive Blast Cleaning.** Meet the surface preparation requirements of SSPC-SP 10 unless otherwise shown on the plans. Ensure a minimum profile of 1.5 mils. Do not add depth to existing profile when the surface profile exceeds 4.0 mils. Measure surface profile in accordance with ASTM D4417, Method C, "Standard Test Methods for Field Measurement of Surface Profile of Blast Cleaned Steel." Containment mounting points and other repair areas under 1 sq. ft. may be tool-cleaned to SSPC SP-11 with at least a minimum 2 mil profile when approved by the Engineer.
- 4.7.3.2.2. **Tool Cleaning.** Meet the requirements of SSPC-SP2 or SP3 unless otherwise shown on the plans. Probe the perimeter of peeled areas of paint with a putty knife to ensure remaining paint is tightly adhered.
- 4.7.3.2.3. **Water Blasting.** Meet the requirements of SSPC-SP WJ-4. Tight mill scale and tightly adhered rust and paint are permitted. Probe the perimeter of peeled areas of paint with a putty knife to ensure remaining paint is tightly adhered.
- 4.7.3.3. **Tape Test.** Perform the tape test, as necessary to determine cleanliness, on any surface before painting as follows:
- Press a strip of filament tape onto the surface by rubbing with moderate thumb pressure 4 times, leaving approximately 2 in. of one end of the tape free from the surface.
 - Grasp the free end and remove the tape from the surface with a sharp pull.

The surface will be considered to be contaminated and not adequately cleaned if visible particles cling to the tape.

- 4.7.4. **Painting.**

- 4.7.4.1. **Paint Condition.** Thoroughly mix and strain paints to be applied. Mix by mechanical methods. Provide continuous mechanical agitation during painting operations to prevent settling. Ensure the paint is a completely homogeneous mixture free of lumps, skins, and agglomerates and contains all pigments, vehicle

solids, and thinners required in the original formulation. Keep paint containers tightly covered and protected from weather when not in use.

- 4.7.4.2. **Thinning.** Adjust paint to the correct application consistency by using suitable thinners or by using properly applied heat up to 150°F. Using heat to thin paints may decrease their useful pot life.
- 4.7.4.3. **Paint System Requirements.** Ensure all coatings in the paint system, including shop-applied coats, are from the same manufacturer.
- 4.7.4.4. **Stripe Coat.** All stripe coat, when specified, will be unthinned and worked in by brush to achieve a contiguous film over all edges, corners, bolts, nuts, threads, rivets, and weld seams, extending at least 1 in. onto adjacent steel.
- 4.7.4.5. **Paint Systems.**
- 4.7.4.5.1. **System I-A (Overcoating, One Coat).** Apply at least 4.0 mils dry film thickness (DFT) maintenance overcoat to all surfaces to be painted.
- 4.7.4.5.2. **System I-B (Overcoating, High Corrosion Environment).**
- **Penetrating Sealer.** Apply 0.5–1.0 mil DFT of penetrating sealer to all surfaces to be painted.
 - **Prime Coat.** Apply 4.0–8.0 mils DFT of primer to areas that have received tool cleaning and to other areas where there is no existing primer.
 - **Appearance Coat.** Apply 2.0–6.0 mils DFT of appearance coat.
- 4.7.4.5.3. **System II.**
- **Prime Coat.** Apply 3.5–10.0 mils DFT of primer in at least 2 coats.
 - **Appearance Coat.** Apply 2.0–5.0 mils DFT of appearance coat.
- 4.7.4.5.4. **System III-A.**
- **Prime Coat.** Apply at least 3.5 mils DFT of epoxy zinc primer.
 - **Stripe Coat.** Apply stripe coat of epoxy intermediate coating.
 - **Intermediate Coat.** Apply at least 2.0 mils DFT of epoxy intermediate coating.
 - **Appearance Coat.** Apply at least 2.0 mils DFT of appearance coating.
- 4.7.4.5.5. **System III-B.**
- **Prime Coat.** Apply at least 3.0 mils DFT of inorganic zinc primer to new steel in accordance with Item 441, "Steel Structures." Spot-clean all damaged and unpainted areas in accordance with Section 446.4.6., "Cleaning and Painting New Steel." Apply at least 3.0 mils DFT of epoxy zinc primer to the spot cleaned areas.
 - **Stripe Coat.** Apply stripe coat of epoxy intermediate coating.
 - **Intermediate Coat.** Apply at least 2.0 mils DFT of epoxy intermediate coating.
 - **Appearance Coat.** Apply at least 2.0 mils DFT of appearance coat.
- 4.7.4.5.6. **System IV.**
- **Prime Coat.** Apply at least 3.0 mils DFT of inorganic zinc primer to new steel in accordance with Item 441, "Steel Structures." Spot-clean all damaged and unpainted areas in accordance with Section 446.4.6., "Cleaning and Painting New Steel." Apply at least 3.0 mils DFT of epoxy zinc primer to the spot cleaned areas.
 - **Appearance Coat.** Apply at least 2.0 mils DFT of appearance coat.
- 4.7.4.5.7. **Special Protection System.** Apply paint as shown on the plans.

4.7.4.6. **Temperature.** Do not apply #810 Prime Coat when the steel or air temperature is below 50°F or when the steel or air temperature is expected to drop below 50°F within 2 hr. after application. Follow product data sheets for temperature requirements for all other paints.

4.7.4.7. **Application.** Clean steel surfaces or surfaces of previously applied coats of paint immediately before painting by blowing with clean compressed air, brushing, or both to remove traces of dust or other foreign particles. Wash the surfaces of previously applied coatings either with clean, fresh water or with a mild detergent and water mixture followed by a complete and thorough rinse with clean, fresh water when directed.

Do not apply paint to any surface with discernible moisture. Do not apply paint to any surface when steel is within 5°F of the dewpoint. Do not apply any paint when impending weather conditions might result in injury to fresh paint.

Provide environmental controls such as dehumidification, heaters, or additional containment measures as needed to control and maintain favorable atmospheric conditions in all areas of the containment. Provide environmental controls at no additional cost to the Department.

Apply each coat of paint to clean, dry, firm surfaces complying with all specification requirements. Ensure surfaces to be painted are free of all forms of contamination. Ensure each coat fully cures to form a smooth, continuous, tightly adhering film of uniform thickness and appearance, free of sags, runs, pinholes, holidays, overspray, or other defects before applying the next coat. Apply all coats by spray, except brush-applied stripe coats. Obtain Engineer approval for alternative methods of application to paint inaccessible areas.

Repair all runs, sags, and other defects in each coat of paint before application of subsequent coats.

Measure the dry film thickness of coatings in accordance with Tex-728-I.

If, in the opinion of the Engineer, there is an objectionable amount of dust in the atmosphere, discontinue painting or take necessary precautions to prevent dust and dirt from coming in contact with freshly painted surfaces or with surfaces before the paint is applied.

Provide full coverage of the steel with the concrete surface when painting steel that is in contact with concrete. Do not extend the paint more than 4 in. onto the concrete surfaces or as directed. Ensure when painting is complete the only visible paint on concrete surfaces is the finish coat. Remove excessive or objectionable paint on concrete surfaces in an approved manner.

Cure the primer, when System II is specified, in accordance with Table 1 before applying appearance coat.

Table 1
System II Primer Cure Times

Temperature	Days Cure, Min
77°F and above	2
65–77°F	3
55–65°F	4
40–55°F	5

Clean coated surfaces by an approved method that does not damage the paint to remove all dirt, grease, concrete, overspray, and any other substance that may impair adhesion before the application of the next coat.

Provide an even and uniform appearance throughout the painted portion of the structure.

4.7.4.8. **Workmanship.** Perform all painting with skilled painters who can adjust equipment and application techniques as dictated by the type of paint, weather conditions, environment, and size and shape of the surface being painted. Painters who, in the opinion of the Engineer, do not adjust equipment to apply coatings in a uniform, full wet coat free of runs, sags, holidays, and overspray will not be considered skilled painters.

Apply sprayed coatings essentially 90° to the surface and between 10 and 18 in. from the surface as necessary to apply a full wet coat of paint free of overspray, runs, sags, and holidays. Any spray painter who does not consistently spray in this manner or extends the spraying stroke so paint is applied to the surface at an angle of less than 80° will not be allowed to spray paint. Brush application for touchup is acceptable as long as the paint is mixed in the appropriate proportions by weight and is agitated continuously during the painting operation.

- 4.7.5. **Handling and Shipping.** Pad the blocks, chains, slings, braces, clamps, etc., used for handling, moving, storing, and shipping painted members so the paint will not be damaged.
- 4.8. **Paint Improperly Applied.** To uncover evidence of improperly applied paint, the Engineer may at any time during construction explore underneath the surface of any paint coats already applied. Repair these areas of investigation at no additional expense to the Department. Whenever unsatisfactory conditions are found, the Engineer may require remedial measures.

Repair or completely remove and replace all paint that has been applied improperly, has been applied to improperly cleaned surfaces, fails to dry and harden properly, fails to adhere tightly to underlying metal or other paint film, or does not have a normal, workmanlike appearance in conformance with this Item. When the final field coat does not have a uniform color and appearance throughout the structure, correct it by the use of whatever additional coats or other corrective measures are required. Remove freshly applied paint that has not yet set with the use of suitable solvents. Remove dried paint films with blast cleaning, scraping, or flame torches, as approved.

- 4.9. **Storage and Disposal.** Collect all waste generated by cleaning and painting operations as necessary to prevent release into the environment. At a minimum, collect all waste before leaving the jobsite each day. Handle and store the waste as if it was hazardous or Universal Waste until classification is made. Follow the requirements of 30 TAC 335 for on-site handling of the waste. Store waste collected in containers that comply with 49 CFR Part 178. Seal containers containing waste each day before leaving the jobsite.

Test a representative sample of waste using EPA Test Method 1311, "Toxicity Characteristic Leaching Procedure" (TCLP), to determine existing metal and organic content. Handle and dispose of non-hazardous waste as a "Special Waste" as defined in 30 TAC 330.2 or as directed. Provide documentation showing disposal of the waste was done in a suitable landfill holding permits to handle this type of material. Dispose of hazardous waste in compliance with applicable waste rules and regulations. Transport hazardous waste using a permitted transporter and dispose of in an authorized hazardous waste facility.

When the plans specify the existing coating to be removed contains hazardous materials and steel grit is used as the abrasive, the waste generated is classified as hazardous or Universal Waste regardless of the results of the TCLP. For manifesting purposes, the Department is considered the waste generator for paint removal wastes generated from structures owned or controlled by the State. Dispose of this waste in compliance with applicable waste rules and regulations as specified above and by the Contract.

Provide copies of all test reports and transportation manifests to the Engineer before shipping waste. Provide signed original manifests to the Engineer verifying all steps of the handling and disposal process were correctly handled.

- 4.10. **Miscellaneous.** Notify the Engineer of any condition that may require the repair or replacement of any portion of the bridge.

Stencil on the exterior face of the outside beam the control, section, and structure number upon completion of the painting operations for each structure as directed. Stencil on the interior face of the outside beam the completion date of the painting operation. Do this work at each end of the structure where painting is specified.

5. MEASUREMENT

When this Item is specified on the plans to be a pay item, this Item will be measured by the lump sum or by each structure, structure unit, or group of structures as shown on the plans.

6. PAYMENT

When this Item is specified as a pay item, the work performed and materials furnished in accordance with this Item and measured as provided under "Measurement" will be paid for at the price bid for "Cleaning and Painting Existing Structures," "Cleaning and Painting Existing Railing," or "Cleaning and Painting Existing Piling" for the system specified and, when paid by each, for the structure description by reference number. "Cleaning and Painting Existing Structures" includes painting of railing and piling unless otherwise shown on the plans. This price is full compensation for paint; cleaning, spot painting, and painting; removal of vegetative obstructions; containment systems; traffic protection and scaffolding; disposal of waste; and materials, equipment, labor, tools, and incidentals.

When the Item is not specified as a pay item, the work performed and materials furnished in accordance with this Item will not be measured or paid for directly but will be subsidiary to pertinent Items.

Item 447

Structural Bolting



1. DESCRIPTION

Furnish and install high-strength bolts for structural connections.

2. MATERIALS

- 2.1. **General.** Use the same supplier for bolts and nuts to ensure proper fit. Have the manufacturer or distributor perform rotational-capacity (R-C) tests in accordance with Tex-452-A on all bolt, nut, and washer assemblies. Test each combination of bolt production lot, nut lot, and washer lot as an assembly and assign an R-C lot number to each lot tested. Test 2 samples from each assigned R-C lot.

Furnish a manufacturer's certified test report (MCTR) or a distributor's certified test report (DCTR) for each R-C lot supplied. Include in the MCTR or DCTR:

- results of the R-C tests,
- R-C lot number,
- manufacturing location for assembly components,
- date and location of tests, and
- a statement that the materials represented by the test report conform to the specifications.

- 2.2. **Bolt Assemblies.** Provide bolts, nuts, and washers meeting the type, grade, and finish requirements in Table 1.

Use ASTM A325 or A490 Type 3 plain (uncoated) bolts for weathering steel as indicated and ASTM A325 Type 1 galvanized bolts for coated steel.

Provide bolts long enough for the installed bolt end to be flush with or outside the face of the nut.

Ensure galvanized nuts are lubricated with a lubricant containing a dye of a color that contrasts with the color of the galvanizing. Order ASTM A563 nuts with supplemental requirement S2 if they will be galvanized.

Table 1
ASTM Type, Finish, and Grade for Structural Bolts, Nuts, and Washers

	ASTM Designation	Bolt Type	Bolt Finish	ASTM A563 Nut Grade and Finish	ASTM F436 Washer Type and Finish
Heavy-Hex Bolts	A325	1	Galvanized	DH, ¹ galvanized and lubricated	1; galvanized
	A325	3	Plain	C3 and DH3; plain	3; plain
	A490	3	Plain	DH3; plain	3; plain
Tension-Control Bolts			Galvanized	DH, ¹ galvanized and lubricated	1; galvanized
		3	Plain	C3 and DH3; plain	3; plain
	F2280	3	Plain	DH3; plain	3; plain

1. ASTM A194 Heavy Hex Grade 2H nuts may be substituted.

- 2.3. **Washer-Type Indicating Devices.** Use compressible-washer-type direct tension indicators that meet ASTM F959 if allowed. Alternative washer-type indicating devices must be approved by Engineer. Provide detailed testing, installation, and inspection requirements prepared by the manufacturer.

- 2.4. **Storage.** Protect all bolts and nuts from dirt and moisture at the jobsite. Remove from protected storage only those bolts and nuts anticipated to be installed during a workday. Return unused fasteners to protected

storage at the end of the day. Do not clean fasteners of lubricant present in the as-delivered condition. Perform a field R-C test at the Contractor's expense in accordance with Tex-452-A on any lot of fasteners that shows signs of rust, dirt, or loss of lubrication as directed. Apply additional lubrication and rerun the R-C test before installing bolts if the fasteners fail the R-C test. Replace any fasteners that cannot be re-lubricated to pass the field R-C test. Tension control bolts may only be re-lubricated by the manufacturer.

- 2.5. **Sampling and Testing.** Sample high-strength bolts, nuts, and washers in accordance with Tex-719-I. Perform field R-C tests as directed in accordance with Tex-452-A. Perform installation verification tests required in Section 447.4.1., "Verification Testing."
- 2.6. **Fitup Bolts and Erection Pins.** Provide heavy-hex fitup bolts of the same diameter as the connection bolts. Do not use washer-type indicating devices for fitups. Do not reuse galvanized bolts or ASTM A490 bolts that have been used as fitup bolts. Provide a sufficient number of erection or drift pins, 1/32 in. larger than the bolt diameter.
- 2.7. **Paint Markers.** Provide white or yellow paint markers for marking bolts or nuts for wrench calibration, R-C Tests, and bolt installation.

3. EQUIPMENT

- 3.1. **Testing Equipment.** Provide a calibrated tension-measuring device (Skidmore-Wilhelm or equivalent), calibrated torque wrench, and other accessories necessary to perform the installation verification test and the R-C test and to calibrate hydraulic or electric torque wrenches.
- 3.2. **Wrenches.** Furnish either of the following types of wrenches.
- 3.2.1. **Air-Driven Impact Wrenches.** Furnish air-driven impact wrenches, air compressors, and related accessories of sufficient capacity to properly tension high-strength bolts. Impact wrenches should be of sufficient size and capacity to be able to tension fully a bolt in less than 15 sec. Repair or replace any wrenches that are unable to apply full tension to a bolt within this time.
- 3.2.2. **Calibrated Torque Wrenches.** Furnish calibrated hydraulic or electric torque wrench and related accessories capable of properly tensioning high-strength bolts. Calibrate the wrench to stall out or cut out completely when the bolt tension reaches 1.05 times the tension specified in Table 2. Calibrate the wrench by tensioning 3 bolts of each size in a calibrated tension-measuring device (Skidmore-Wilhelm or equivalent). Mark each bolt and verify the rotation from snug-tight when calibrating the wrench as specified in Section 447.4.5.3.1., "Turn-of-the-Nut Method." Calibrate the wrench at least once each working day or as directed. Recalibrate the wrench for changes in bolt diameter; changes in bolt length greater than 2 bolt diameters; significant differences in the surface condition of the bolts, threads, nuts, or washers; or changes in the equipment or hose length.

4. CONSTRUCTION

- 4.1. **Verification Testing.** Have each member of the bolting crew that will perform the actual work complete an acceptable pre-installation verification test in the presence of the Engineer. Only crewmembers that have demonstrated proper workmanship via verification testing may perform production bolting work.
- 4.1.1. **Air-Driven Impact Wrench.** Perform an installation verification test on 3 complete fastener assemblies of each combination of diameter, length, grade, and lot to be installed before beginning bolting. Follow the bolt-tensioning procedures in Section 447.4.5.3., "Tension Bolts." Use a calibrated tension-measuring device (Skidmore-Wilhelm or equivalent) to verify and demonstrate that the method for estimating the snug-tight condition and controlling the turns from snug-tight develops a tension greater than 1.05 times the tension specified in Table 2. The snug-tight condition is defined as the tightness that exists when the plies of the joint are in firm contact.

4.1.2. **Calibrated Torque Wrench.** Calibrate the wrench before beginning bolting in accordance with Section 447.3.2.2., "Calibrated Torque Wrenches." Use the bolting crew that will perform the actual work for the calibration and calibrate the wrench in the presence of the Engineer. Follow the bolt-tensioning procedures in Section 447.4.5.3., "Tension Bolts."

4.1.3. **Direct-Tension Indicator.** Use a calibrated tension-measuring device for compression-type indicators to verify the gap is not less than 0.015 in. or the job inspection gap specified by the manufacturer when tension in the bolt reaches 1.05 times the tension specified in Table 2.

Follow the manufacturer's instructions for pre-installation verification testing methods and frequency for alternative washer-type indicating devices deemed acceptable.

4.2. **Workmanship.** The Engineer will disqualify any crewmembers not adhering to proper installation methods during production work. Disqualified crew may not perform further bolting work until they complete an additional pre-installation verification test suitable to the Engineer.

4.3. **General.** Ensure all material within the grip of the bolt is steel. Do not allow any compressible material such as gaskets or insulation within the grip. Ensure the slope of parts in contact with the bolt head or nut does not exceed 1:20 with respect to a plane normal to the bolt axis. Prepare all joint surfaces, including those in contact with the bolt heads, nuts, or washers, so that the surfaces are free of dirt, loose rust, loose mill scale, burrs, and other matter that would prevent solid seating of the parts.

Replace any bolts and nuts installed for shipping purposes unless the shop drawings indicate the shop-installed bolts are to be fully tensioned in the shop. Do not tension bolts that have been installed snug-tight in the shop. Remove any bolts installed snug-tight in the shop and replace them with new bolts. Inspect and prepare the joint surfaces after removing shop-installed bolts that are not fully tensioned in the shop.

Provide a hardened washer for heavy-hex and tension-control bolts under either the nut or the bolt head, whichever is turned during tensioning. Install hardened washers under both the nut and bolt head of ASTM A490 bolts when the outer plies being fastened have a yield strength less than 40 ksi.

Install an ASTM F436 washer for direct tension indicators as follows:

- under the nut when the nut is turned and the direct tension indicator is located under the bolt head;
- between the nut and the direct tension indicator when the nut is turned and the direct tension indicator is located under the nut;
- under the bolt head when the bolt head is turned and the direct tension indicator is located under the nut; and
- between the bolt head and the direct tension indicator when the bolt head is turned and the direct tension indicator is located under the bolt head.

Tension all bolts to provide the minimum bolt tension values given in Table 2.

Erect steel in conformance with Item 441, "Steel Structures." Do not tack-weld any parts to eliminate fitup bolts or to hold parts together while bolting.

Remove lubricant from bolt assemblies on painted structures after tensioning and before coating the connections.

Re-tighten the nuts or tack weld the nuts to the bolts when bolts are used to temporarily support welded diaphragms after completing the welding operations if the diaphragms are over vehicular or pedestrian traffic.

Table 2
Bolt Tension

Nominal Bolt Size, in.	Minimum Tension (kips)	
	ASTM A325 Bolts	ASTM A490 Bolts
1/2	12	15
5/8	19	24
3/4	28	35
7/8	39	49
1	51	64
1-1/8	56	80
1-1/4	71	102
1-3/8	85	121
1-1/2	103	148

- 4.4. **Preparation of Faying Surfaces.** Perform blast cleaning or painting of faying surfaces in accordance with Item 441, "Steel Structures." Provide an SSPC-SP 10 blast cleaning before shipment for weathering steel. Do not wire-brush weathering steel faying surfaces.
- Roughen galvanized faying surfaces by hand wire-brushing. Do not use power wire brushes to roughen galvanized faying surfaces.
- 4.5. **Bolt Installation.** Use the following procedure for bolt installation of a complete connection:
- 4.5.1. **Fair-Up Holes.** Use a minimum number of erection or drift pins, as directed, in the holes to "fair-up" all holes.
- 4.5.2. **Install Bolts.** Install bolts in all remaining holes of the connection. Do not use excessive force, which results in damage to the threads, to install the bolts. Increase the number of erection or drift pins as necessary to align the holes if force is required to install the bolts. Do not ream the holes unless approved. Ream the holes in accordance with Section 441.3.11.5., "Misfits," if approved. Remove the erection or drift pins and install bolts in these holes. Bring the connection to a full snug-tight condition by snugging systematically from the most rigid part of the connection to the free edges. The snug-tight condition is defined as the tightness that exists when the plies of the joint are in firm, full contact and all of the bolts in the joint have been tightened sufficiently to prevent the removal of the nuts without the use of a wrench. A snug-tight condition can usually be attained by a few impacts of an impact wrench or the full effort of a worker using an ordinary spud wrench as demonstrated in the installation verification test. As necessary, re-snug previously snugged bolts that may have relaxed as a result of the subsequent snugging of adjacent bolts to ensure all bolts are simultaneously snug-tight and the connection plates are in full contact.
- Fully tighten a minimum number of bolts as directed until the plies are in full contact if snugging does not bring the plies of the joint into full contact. Mark these bolts as fitup bolts. Use a non-galvanized ASTM A325 bolt of the same diameter as a fitup bolt in connections requiring the use of galvanized ASTM A325 bolts. Re-snug all remaining bolts.
- Do not use washer-type indicating devices to bring the connection to a snug-tight condition. Rather, install heavy-hex bolt assemblies in a sufficient number of holes (approximately 20%) to attain firm, full contact between plies. Remove the heavy-hex bolts and install the washer-type indicating device assemblies after firm contact is established by connections in surrounding bolt holes.
- 4.5.3. **Tension Bolts.** Loosen all fitup bolts after tensioning all the other bolts in the connection. Ungalvanized ASTM A325 bolts used as fitup bolts may be reused in a connection using this type of bolt. Replace all galvanized bolts and ASTM A490 bolts used as fitup bolts. Tension these remaining untensioned bolts in accordance with this paragraph. Ensure the element not turned by the wrench (bolt head or nut) does not rotate.
- 4.5.3.1. **Turn-of-the-Nut Method.** Match-mark the nuts and the protruding bolt ends after the bolts have been brought up to snug-tight condition and before final tensioning so that actual rotation can be determined.

Tension all bolts in the connection to their final tension by the amount of rotation specified in Table 3. Start final tensioning at the center or most rigid part of the connection and progress toward the free edges.

- 4.5.3.2. **Calibrated Wrench Method.** Use a calibrated hydraulic torque wrench to tension all bolts to 1.05 times the tension given in Table 1 after they have been brought to the snug-tight condition. Calibrate the wrench in accordance with Section 447.3.2.2., "Calibrated Torque Wrenches." Start tensioning at the most rigid part of the connection and proceed to the free edges. Return the wrench to re-tension previously tensioned bolts that may have relaxed as a result of the subsequent tensioning of adjacent bolts. Place marks on the socket at one-third points so the amount of rotation can be visually determined.
- 4.5.3.3. **Washer-Type Indicating Devices.**
- 4.5.3.3.1. **Compressible-Washer-Type Direct Tension Indicators.** Ensure the direct-tension indicator arches are oriented away from the work and that they bear against the hardened bearing surface. Confirm the appropriate feeler gage is 1) accepted in at least half the spaces between protrusions before tensioning, and 2) refused entry in at least half the spaces between protrusions after tensioning.
- 4.5.3.3.2. **Alternative Washer-Type Indicating Devices.** Follow the procedures prepared by the manufacturer and approved by the Engineer. Verify proper installation after tensioning.
- 4.5.4. **Bolt Reuse.** Do not reuse ASTM A490 or galvanized ASTM A325 bolts. Ungalvanized ASTM A325 bolts may be reused one time if the threads have not been damaged. Re-tensioning previously tensioned bolts loosened by the tensioning of adjacent bolts is not considered to be reuse.

Tension all bolts in a connection within 10 days of installation. Bolts not tensioned within 10 days of installation are subject to field R-C testing. Re-lubricate or replace any installed bolts that do not have sufficient lubrication as determined by the field R-C test.

Table 3
Nut Rotation from Snug-Tight Condition¹

Bolt length (underside of head to end of bolt)	Disposition of Outer Face of Bolted Parts		
	Both faces normal to bolt axis	One face normal to bolt axis and other face sloped less than 1:20 (beveled washer not used)	Both faces sloped less than 1:20 from bolt axis (beveled washer not used)
Up to and including 4 bolt diameters	1/3 turn	1/2 turn	2/3 turn
Over 4 bolt diameters up to and including 8 diameters	1/2 turn	2/3 turn	5/6 turn
Over 8 bolt diameters up to and including 12 diameters ²	2/3 turn	5/6 turn	1 turn

1. Nut rotation is relative regardless of the element (nut or bolt) being turned. The tolerance is -0° , $+30^{\circ}$ for bolts installed by 1/2 turn or less and -0° , $+45^{\circ}$ for bolts installed by 2/3 turn or more.
2. Determine the required rotation for bolt lengths greater than 12 diameters using the installation verification test in a simulated connection of solidly fitted steel.

5. MEASUREMENT AND PAYMENT

Installation and testing of bolts will not be paid for directly but will be subsidiary to the pertinent Items requiring the use of high-strength bolts.

When payment for the structure associated with the bolts is made under Item 442, "Metal for Structures," bolts, nuts, and washers will be paid for in accordance with Item 442, "Metal for Structures."

Item 448

Structural Field Welding



1. DESCRIPTION

Field-weld metal members using the shielded metal arc or flux cored arc welding processes.

2. MATERIALS

Provide electrodes for shielded metal arc welding (SMAW) conforming to the requirements of the latest edition of ANSI/AWS A5.1 or ANSI/AWS A5.5.

Provide electrodes for flux cored arc welding (FCAW) conforming to the requirements of the latest edition of ANSI/AWS A5.20 or ANSI/AWS A5.29.

Provide electrodes and flux-electrode combinations named on the Department's MPL. To request that a product be added to this list or to renew an expired approval, the Contractor or the consumable manufacturer must submit certified reports of all tests required by the applicable AWS A5 specification according to the applicable welding code to the Construction Division. For most structural steel construction, the applicable welding code is AASHTO/AWS D1.5 or ANSI/AWS D1.1. For reinforcing steel, the applicable code is ANSI/AWS D1.4. Tests must be conducted on electrodes of the same class, size, and brand and manufactured by the same process and with the same materials as the electrodes to be furnished. Resubmit electrodes or flux-electrode combinations every 12 months for renewal.

Table 1 shows the classes of electrodes required. Use electrodes with the type of current, with the polarity, and in the positions permitted by AWS A5.1 and A5.5 for SMAW. AWS A5.20 and A5.29 specifications govern for FCAW. Obtain approval for electrode use on steel not listed in Table 1.

Table 1
Classification of Electrodes Permitted

Type of Steel (ASTM Standards)	Electrode Specification	Process	Filler Metal Requirements
Steel piling	AWS A5.1 or A5.5	SMAW	E60XX E70XX or E70XX-X
Armor joints A500 A501	AWS A5.20 or A5.29	FCAW	E6XTX-X E7XTX-X (except -2, -3, -10, -GS)
A36 A572 Gr. 50 A588	AWS A5.1 or A5.5	SMAW	E7016 E7018 E7028
A242 A709 Gr. 36, 50, or 50S	AWS A5.20 or A5.29	FCAW	E7XT-1 E7XT-5 E7XT-6 E7XT-8
Weathering steel	AWS A5.5	SMAW	E8018-W E8016-C3 E8018-C3 E8016-C1 E8018-C1 E8016-C2 E8018-C2
A588 A242 A709 Gr. 50W	AWS 5.29	FCAW	E8XT1-W E8XTX-Ni1 E8XTX-Ni2 E8XTX-Ni3
A709 Gr. HPS 70W	AWS A5.5	SMAW	E9018-M-H8R
Reinforcing steel Grade 40	AWS A5.1 or A5.5	SMAW	E70XX
Reinforcing steel Grade 60	AWS A5.5	SMAW	E90XX
Permanent metal deck forms	AWS A5.1 or A5.5	SMAW	E6010 E6011 E6013 E7018

Note—Low-hydrogen electrodes applicable to the lower strength base metal may be used in joints involving base metals of different yield points or strengths.

E7010 and E8010 electrodes may be used when welding the root passes of beam and girder splices if the requirements of Section 448.4.3.5.1., “High-Cellulose Electrodes for Root Passes,” are met.

Use electrodes meeting the diffusible hydrogen requirements for fracture-critical welding in AASHTO/AWS D1.5 when welding fracture-critical applications.

Use gas or gas mixtures that are welding grade and have a dew point of -40°F or lower for gas-shielded FCAW. Furnish certification to the Engineer that the gas or gas mixture is suitable for the intended application and will meet the dew point requirements.

3. EQUIPMENT

Provide electrode drying and storing ovens that can maintain the required temperatures specified in Section 448.4.3.1., “Electrode Condition.” Each oven must have a door that is sealed and can be latched. Each oven must have a small port that may be opened briefly to insert a thermometer or the oven must be equipped with a thermometer that allows for direct reading of temperature inside the oven without opening the oven. Provide equipment able to preheat and maintain the temperature of the base metal as required and as shown on the plans. Provide approved equipment (e.g., temperature indicator sticks or infrared thermometer) for checking preheat and interpass temperatures at all times while welding is in progress.

Provide welding equipment meeting the requirements of the approved welding procedure specifications (WPS), if required, and capable of making consistent high-quality welds.

4. CONSTRUCTION

- 4.1. **Procedure Qualification.** Use the proper classification and size of electrode, arc length, voltage, and amperage for the thickness of the material, type of groove, welding positions, and other circumstances of the work.
- Submit WPSs for FCAW, qualified in accordance with AASHTO/AWS D1.5 for approval before any field welding on a project.
- 4.2. **Welder Qualification.** Provide Department certification papers for each welder and for each welding process to be used before welding, except for miscellaneous welds described in Section 448.4.2.1.1., “Miscellaneous Welding Applications.” Certification is issued by the Department as described in Section 448.4.2.2., “Certified Steel Structures Welder.”
- 4.2.1. **Miscellaneous Welding.** A qualified welder is an experienced welder who is capable of making welds of sound quality but does not have Department certification papers. The Engineer will check the welder’s ability by conducting a jobsite test in accordance with Section 448.4.2.1.2., “Miscellaneous Weld Qualification Test,” before welding begins. Furnish all materials and equipment necessary for this test.
- 4.2.1.1. **Miscellaneous Welding Applications.** A welder certified for structural or reinforcing steel or a qualified welder may make miscellaneous welds of the following types:
- splicing reinforcing steel to extend bars in the bottom of a drilled shaft;
 - attaching chairs to the reinforcing steel cage of a drilled shaft;
 - armor joints and their supports;
 - screed rail and form hanger supports where permitted on steel units;
 - reinforcing steel to R-bars for lateral stability between prestressed beams, spirals, or bands to reinforcing bars in drilled shaft cages;
 - permanent metal deck forms;
 - additional steel added in railing when slip-form construction is used; and
 - other similar miscellaneous members that have no load-carrying capacity in the completed structure.
- 4.2.1.2. **Miscellaneous Weld Qualification Test.** A qualified welder must pass a jobsite Miscellaneous Weld Qualification Test before welding:
- Make a single-pass fillet weld of 1/4 in. maximum size in the vertical position approximately 2 in. long on 1/2-in. plate in the location shown in Figure 1. Use the same electrode proposed for the work.
 - The Engineer will visually inspect the fillet weld for a reasonably uniform appearance and then rupture the weld as shown in Figure 2 with a force or by striking it with a hammer.
 - The fractured surface of the weld will be inspected to ensure complete penetration into the root of the joint, complete fusion to the base metal, and no inclusion or porosity larger than 3/32 in. in its greatest dimension.

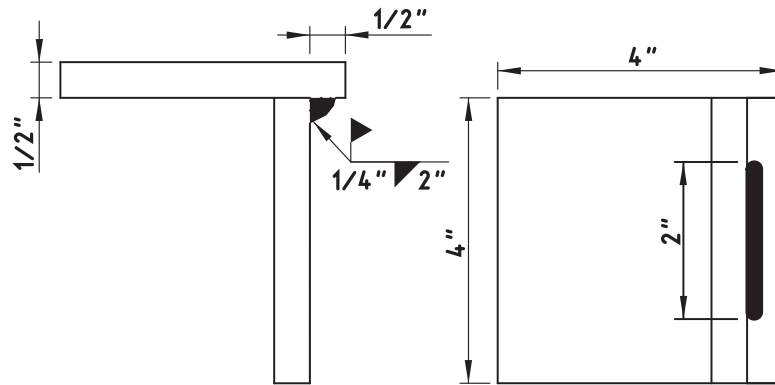

Figure 1
Miscellaneous Qualification—Fillet Weld Break Specimen

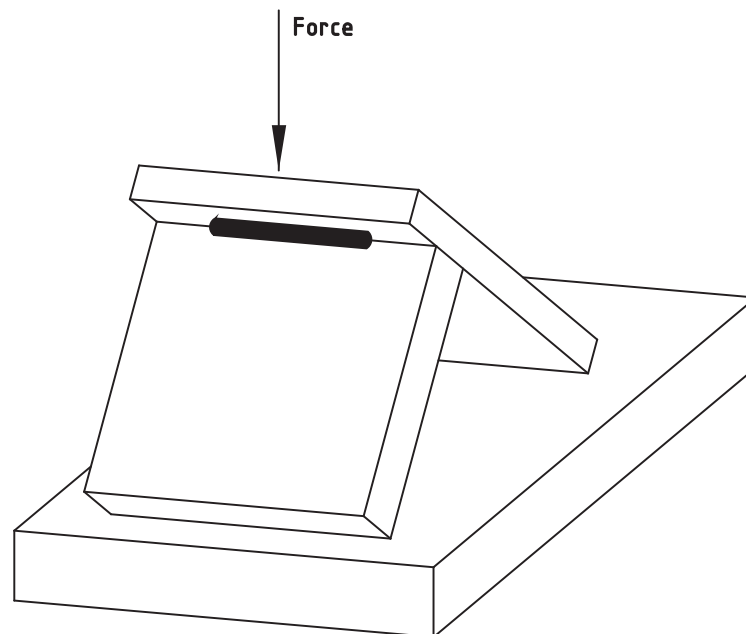

Figure 2
Miscellaneous Qualification—Method of Rupturing Specimen

A welder who fails the Miscellaneous Weld Qualification Test may take a retest under the following conditions:

- The retest occurs immediately and consists of 2 test welds as described above with both test specimens meeting all of the requirements.
- The retest occurs after 30 days if the welder provides evidence of further training or practice. In this case the test consists of a single test weld.

Qualification by the Miscellaneous Weld Qualification Test is effective immediately upon satisfactory completion of the test and remains in effect for the duration of a project.

4.2.2.

Certified Steel Structures Welder. Before making non-miscellaneous welds on structural steel, a welder must pass the AASHTO/AWS D1.5 qualification test for groove welds for plates of unlimited thickness in the vertical (3G) and overhead (4G) positions with the following additional requirements:

- Use metal for test plates that meets Item 442, "Metal for Structures," with a minimum yield point of 36 ksi. The minimum width of test plate must be sufficient to accommodate the radiograph inspection of 5-1/4 continuous inches of the weld, not counting the ends of the weld.
- Use approved electrodes meeting the required class in accordance with Table 1 and, in the case of FCAW, in accordance with the approved WPS.
- Have a radiographic inspection performed on the weld on each test plate. Any porosity or fusion-type discontinuity with greatest dimension larger than 1/16 in. found in the weld will result in failure of the test. Discontinuities with greatest dimension less than 1/16 in. are acceptable provided the sum of their greatest dimensions does not exceed 3/8 in. in any inch of weld.
- Have 2 side-bend specimens prepared, tested, and inspected for each test plate.

The test must be administered by an approved laboratory and welding observed by laboratory personnel. Submit 2 copies of the certification issued by the laboratory, all accompanying test papers, and the radiographic films to the Bridge Division for review. The Bridge Division issues Department certification papers if the laboratory's certification is approved. A welder must also demonstrate to the Engineer a thorough knowledge of the required welding procedures together with the ability and desire to follow them and make welds of sound quality and good appearance. The certification issued by an approved laboratory is accepted for 1 mo. from the time of certification, during which time the welder may work on Department projects if the work is satisfactory. Certification papers issued by the Department remain in effect as long as the welder performs acceptable work as determined by the Bridge Division. The certification may be cancelled at any time if the welder's work is not acceptable.

For SMAW, a welder certified using EXX18 electrodes is qualified to weld with all approved SMAW electrodes up to E90XX to join metals with a maximum specified yield strength of 65 ksi.

4.3.

Welding Steel Structures.

4.3.1.

Electrode Condition.

4.3.1.1.

SMAW. For electrodes with low-hydrogen coverings in conformance with AWS A5.1, dry to the manufacturer's written drying instructions or dry for at least 2 hours between 450°F and 500°F. For electrodes with low-hydrogen coverings conforming to AWS A5.5, dry for at least 1 hour between 700°F and 800°F or as specified by the electrode manufacturer. If using electrodes from a newly opened undamaged hermetically sealed container, drying is not required. Store electrodes in ovens held at a temperature of at least 250°F immediately after drying or removal from hermetically sealed container. Elapsed time permitted between removal of an electrode from the storage oven or hermetically sealed container and use of the electrode is given in Table 2. If the electrodes have the moisture resistance designator "R" and are being used on steel with minimum specified yield strength of 50 ksi or less, exposure time may be increased up to 9 hr.

Table 2
SMAW Electrode Exposure Limits

Electrode Type	Exposure Time (hr.)
E70	4
E80	2
E90	1

Leave electrodes in the holding oven for at least 4 hr. at 250°F before reusing if they are placed back in it before the times given in Table 2 have lapsed. The Engineer may reduce times allowed for use without re-drying in humid atmospheres. Do not redry electrodes more than once. Do not use electrodes with flux that has been wet, cracked, or otherwise damaged.

- 4.3.1.2. **FCAW.** Protect or store welding wire coils removed from the original package to keep their characteristics or welding properties intact. Do not use coils or portions of coils that are rusty.
- 4.3.1.3. **Special Applications.** Dry electrodes for fracture-critical applications or when welding steel not shown in Table 1 in accordance with the manufacturer's specifications and AASHTO/AWS D1.5.
- 4.3.2. **Environmental Conditions.** Do not weld when the air temperature is lower than 20°F; when surfaces are wet or exposed to rain, snow, or wind; or when operators are exposed to inclement conditions. Provide wind breaks to protect welding operations from winds greater than 5 mph.
- 4.3.3. **Assembly and Fitup.** Verify that ends of members to be welded are prepared in accordance with the welded joint detail specified. See Figures 3, 4, and 5 for proper end preparation and weld details of girder splices.

Bring the parts to be joined by fillet welds into as close contact as possible, not separated more than 3/16 in. Increase the leg of the fillet weld by the amount of the separation if the separation is 1/16 in. or more. Keep the separation between faying surfaces of lap joints and of butt joints landing on backing strips to no more than 1/16 in.

Make suitable allowance for shrinkage, and never restrain the joint on both sides in any welding process.

Use the following fitup procedure for groove welds for butt joints:

- Align splices of beams and girders joined by groove welds with the center of gravity of both cross-sections coinciding or each flange vertically offset equally. Fit beams and girders with offset webs with the webs aligned and the flanges offset laterally. Make the joint with a smooth transition between offset surfaces and with a slope of no more than 1:4 when flanges are offset or abutting parts differ in thickness or width by more than 1/8 in.
- Space members to provide a 3/16-in. root opening at the nearest point. At other points of the joint when the spacing provides up to a 7/16-in. opening, correction may be made by buildup up to 1/8 in. on each bevel nose. Rebevel openings exceeding 7/16 in. and move the parts to be joined closer together to bring the joint within the maximum buildup limits. Allow buildups to cool to the maximum preheat and interpass temperatures before welding the joint.
- Bring all members into correct alignment and hold them in position by acceptable clamps while welding.

Complete all butt splices before welding diaphragms or sway bracing in a particular section of a unit. Diaphragms and sway bracing may be welded in a unit behind the splice welding to provide stability except where such welding interferes with butt splice adjustments, such as at a drop-in segment of a continuous unit. Complete all splices before welding beams or girders to shoes.

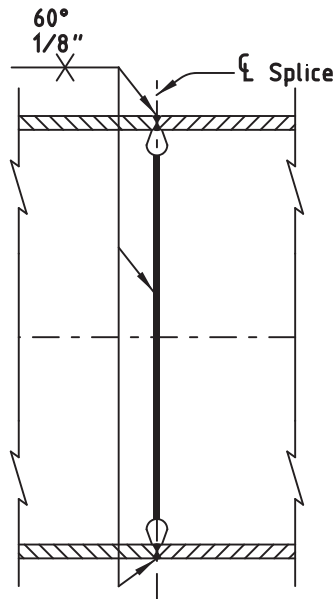

Figure 3
Girder Splice Details

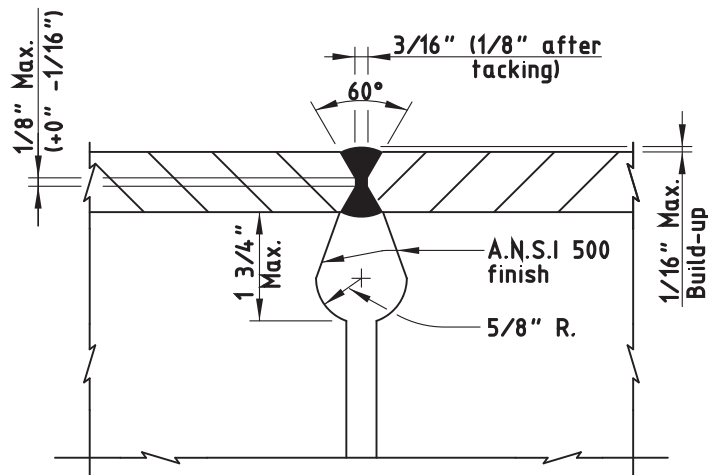

Figure 4
Girder Splice Details (Flange)

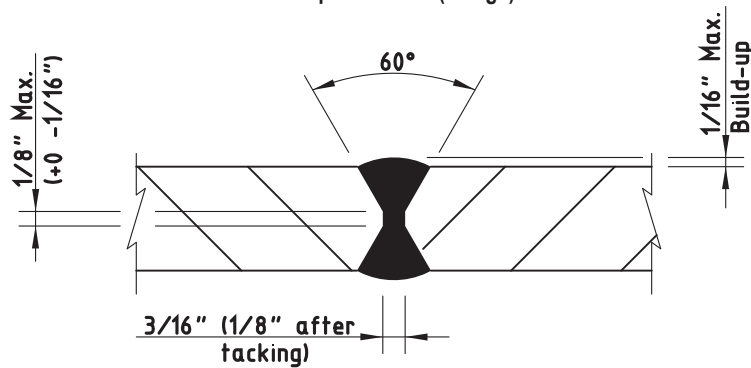

Figure 5
Girder Splice Details (Web)

4.3.4. **Preheat.** Preheat ahead of welding both groove and fillet welds (including tack welding) to the temperatures shown in Table 3. Keep preheat and interpass temperatures high enough to prevent cracks. The preheat

temperatures shown in Table 3 are minimums, and higher preheats may be necessary in highly restrained welds. Preheat the base metal when it is below the required temperature so that parts being welded are not cooler than the specified temperature within 3 in. of the point of welding.

Measure preheat temperature on the side opposite to which the heat is applied at points approximately 3 in. away from the joint.

Completely weld a joint before allowing it to cool below the specified temperature. Always deposit enough weld to prevent cracking before allowing a joint to cool. Do not allow preheat and interpass temperatures to exceed 400°F for thickness up to 1-1/2 in. and 450°F for greater thicknesses.

Table 3
Minimum Preheat and Interpass Temperature for Welding with Low-Hydrogen Electrodes

Thickest Part at Point of Welding	Temperature
Up to 3/4 in., inclusive	50°F
More than 3/4 in. up to 1-1/2 in., inclusive	70°F
More than 1-1/2 in. up to 2-1/2 in., inclusive	150°F
More than 2-1/2 in.	225°F

Preheat the material in accordance with Table 4 when E7010 or E8010 electrodes are used for tacking or temporary root pass.

Table 4
Minimum Preheat Temperature for Welding with E7010 or E8010 Electrodes

Thickest Part at Point of Welding	Temperature
1/2 in. and less	150°F
9/16 in. through 3/4 in.	200°F
13/16 in. through 1-1/2 in.	300°F
More than 1-1/2 in.	400°F

Use preheat and interpass temperatures for the thicker plate thickness when joining steels of different thickness.

Preheat base metal to at least 70°F when the base metal temperature is below 32°F. and maintain this minimum temperature during welding. Preheat base metal to 200°F before starting to weld if it is moist.

Preheat fracture-critical applications in accordance with AASHTO/AWS D1.5.

4.3.5.

Welding Practice. Use an approved procedure to control shrinkage and distortion. Weld FCAW in accordance with an approved WPS. Weld as required by the Contract or erection drawings. Do not change the location or size of welds without approval. Do not make temporary welds for transportation, erection, or other purposes on main members except as shown on the plans or approved. Use a crayon, paint, or other approved method to mark each groove weld to identify the welder who performed the work.

Use the stringer-bead technique where possible for groove welds. Progress upward in vertical welding passes using a back-step sequence keeping the end of the low-hydrogen electrode contained within the molten metal and shield of flux unless the electrode manufacturer's specifications indicate otherwise.

Begin and terminate groove welds at the ends of a joint on extension bars. Make edge preparation and thickness of extension bars the same as that of the member being welded but extending at least 2 in. beyond the joint. Remove extension bars with a cutting torch or arc-air gouging, and grind the flange edges smooth after the weld is completed and cooled. Clean any defects exposed by the grinding, fill them with weld metal, and regrind them to a uniform finish. Grind so that grind marks are parallel to the flange, and avoid excess grinding of the parent metal. Clean and fuse tack welds thoroughly with the final weld. Remove defective, cracked, or broken tack welds.

Gouge, chip, or otherwise remove the root of the initial weld to sound metal for all groove welds, except those produced with the aid of backing or those on steel piling or armor joints, before welding is started on the second side. Clean the back side thoroughly before placing the backup pass. Fuse the weld metal

thoroughly with the backing, and use backing that is continuous for the full length of the weld. Make a continuous length of backing by welding shorter sections together only under the following conditions:

- All splices in the backing are complete joint penetration (CJP) groove welds made with the same controls as similar CJP groove welds in the structure.
- The welds are radiographed and examined as described in Section 448.4.3.7., "Radiographic Inspection," to ensure weld soundness.
- All welding and testing of the backing is complete before the backing is used to make the structural weld.

4.3.5.1. **High-Cellulose Electrodes for Root Passes.** E7010 and E8010 electrodes may be used when welding the root passes of beam and girder splices if the work is preheated in accordance with Table 4. Remove the E7010 or E8010 electrode pass completely by arc-air gouging, and replace it using a low-hydrogen electrode after the root passes are backed up.

4.3.5.2. **Welding Sequence.** Make beam and girder splices using the sequences shown in Figure 6. (Some members will require fewer or more passes than Figure 6 shows.) Alternate welds from flat to overhead to prevent heat buildup along bevel edge. Arrange the passes between the top and bottom flange to maintain balance and symmetry.

Place passes 1, 2, and 3 in the top flange, followed by passes 4, 5, and 6 in the bottom flange (see Figure 6) for rolled I-beams and built-up girders. Gouge out and replace passes 1 and 4, which always are placed in the overhead position. Next, place passes 7, 8, and 9 in the top flange, followed by passes 10, 11, and 12 in the bottom flange. Continue with placing passes 13–17 in the top flange, followed by passes 18–22 in the bottom flange. Continue to alternate welding between top and bottom flange with a maximum of 5 passes per flange until the flange splices are complete. Tack weld web after aligning girder webs with short tacks as required to obtain proper alignment. Place pass 23 and pass 24 on the web. Gouge out and replace pass 23. Finish web splice with pass 25.

Remove all slag for each layer, bead, and the crater area, and clean the weld and adjacent base metal before welding over previously deposited metal. Avoid arc strikes, and if they occur, grind resulting cracks and blemishes out to a smooth contour, checking them visually to ensure soundness.

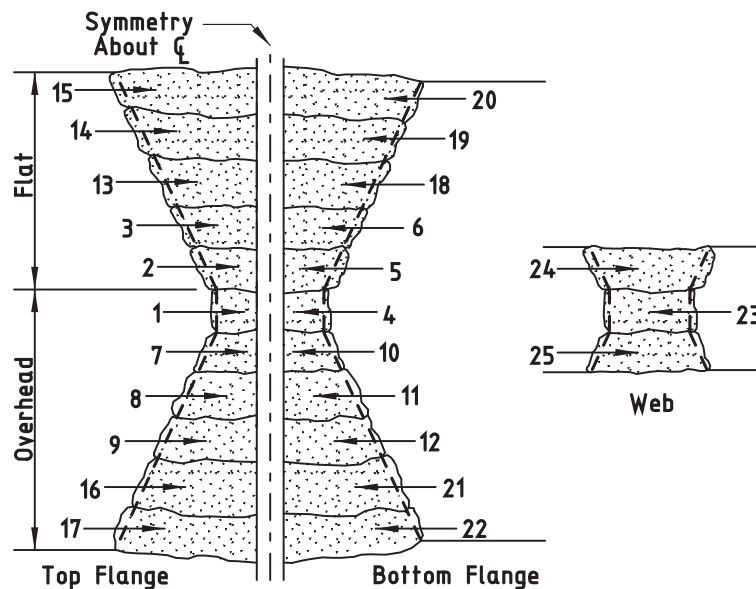

Figure 6
Welding Sequence for Splices for Material up to 50,000-psi Yield Strength.

Deviation from the above sequence of weld passes requires approval. Obtain approval from the Bridge Division for welding procedures and sequences for special connections.

4.3.5.3. **Electrode Size and Weld Layer Thickness.**

4.3.5.3.1. **SMAW.**

4.3.5.3.1.1. **Electrode Size.** Use electrodes with the following maximum size:

- 1/4 in. for all welds made in the flat position except root passes,
- 1/4 in. for horizontal fillet welds,
- 1/4 in. for root passes of fillet welds made in the flat position and of groove welds made in the flat position with backing and with a root opening of 1/4 in. or more,
- 5/32 in. for welds made with low-hydrogen electrodes in the vertical and overhead positions, and
- 3/16 in. for all other welds.

4.3.5.3.1.2. **Weld Size and Layer Thickness.** Make the root pass large enough to prevent cracking. Make layers subsequent to the root pass in fillet welds and all layers in groove welds of the following maximum thickness:

- 1/4 in. for root passes of groove welds;
- 1/8 in. for subsequent layers of welds made in the flat position; and
- 3/16 in. for subsequent layers of welds made in the vertical, overhead, and horizontal positions.

Make fillet welds passes using no larger than:

- 3/8 in. in the flat position,
- 5/16 in. in the horizontal or overhead positions, and
- 1/2 in. in the vertical position.

4.3.5.3.2. **FCAW.**

4.3.5.3.2.1. **Electrode Size.** Use electrodes with the following maximum size:

- 5/32 in. for the flat and horizontal positions,
- 3/32 in. for the vertical position, and
- 5/64 in. for the overhead position.

4.3.5.3.2.2. **Weld Size and Layer Thickness.** Make weld layers, except root and surface layers, no thicker than 1/4 in. Use a multiple-pass split-layer technique when the root opening of a groove weld is 1/2 in. or wider. Use the split-layer technique to make all multiple-pass welds when the width of the layer exceeds 5/8 in.

Ensure each pass has complete fusion with adjacent base metal and weld metal and that there is no overlap, excessive porosity, or undercutting.

Do not use FCAW with external gas shielding in a draft or wind. Furnish an approved shelter of material and shape to reduce wind velocity near the welding to a maximum of 5 mph.

Make fillet weld passes using no larger than:

- 1/2 in. in the flat position,
- 3/8 in. in the horizontal or overhead positions, and
- 5/16 in. in the vertical position.

4.3.6. **Weld Quality.** Provide welds that are sound throughout with no cracks in the weld metal or weld pass. Completely fuse the weld metal and the base metal and each subsequent pass. Keep welds free from overlap, and keep the base metal free from undercut more than 1/100 in. deep when the direction of undercut is transverse to the primary stress in the part that is undercut. Fill all craters to the full cross-section of the welds.

- 4.3.7. **Radiographic Inspection.** Conduct radiographic testing (RT) as required in the field at the expense of the Contractor by an agency or individual registered and licensed to perform industrial radiography. Follow all applicable rules and regulations for radiographic operations. Testing includes furnishing all materials, equipment, tools, labor, and incidentals necessary to perform the required testing. The Department may require further tests in accordance with Article 5.10., "Inspection," and may perform additional testing, including other methods of inspection.
- Perform RT in accordance with AASHTO/AWS D1.5. The Engineer will examine and interpret the resulting radiographs in accordance with AASHTO/AWS D1.5. All radiographs become the property of the Department and remain with the Engineer.
- Radiographically inspect the full flange width of all flange splices and the top and bottom 1/6 of the web at each splice for field-welds of splices in beams or girders. Radiographically retest repaired welds. Make necessary repairs before any further work is done. Additional RT required because of unacceptable welding or poor radiograph quality is at the Contractor's expense. RT of particular welds required by the plans is in addition to the RT required by this Item.
- Meet the requirements specified in Section 441.3.2.5.1., "Radiographic Testing," for radiograph film quality.
- 4.3.8. **Corrections.** When welding is unsatisfactory or indicates inferior workmanship, the Engineer will require corrective measures and approve the subsequent corrections.
- Use oxygen gouging or arc-air gouging when required to remove part of the weld or base metal. Back-gouge splices in beams and girders or cut out defective welds using arc-air gouging by a welder qualified to make beam and girder splices.
- Slope the sides of the area to be welded enough to permit depositing new metal were corrections require depositing additional weld metal.
- Use a smaller electrode than that used for the original weld where corrections require depositing additional weld metal. Clean surfaces thoroughly before re-welding.
- Remove cracked welds completely and repair. Remove the weld metal for the length of the crack if crack length is less than half the length of the weld plus 2 in. beyond each end of the crack, and repair.
- Restore the original conditions where work performed after making a deficient weld has made the weld inaccessible or has caused new conditions making the correction of the deficiency dangerous or ineffectual by removing welds, members, or both before making the necessary corrections; otherwise, compensate for the deficiency by performing additional work according to a revised and approved design.
- Cut apart and re-weld improperly fitted or misaligned parts.
- Straighten members distorted by the heat of welding using mechanical means or the carefully supervised application of a limited amount of localized heat. Do not let heated areas exceed 1,200°F as measured by temperature-indicating crayons or other approved methods for steel up to 65,000-psi yield strength. Do not let heated areas exceed 1,100°F for higher-strength steels. Keep parts to be heat-straightened substantially free of stress from external forces except when mechanical means are used with the application of heat. Before straightening, submit a straightening procedure to the Engineer for approval.
- Correct defective or unsound welds either by removing and replacing the entire weld or as follows:
- 4.3.8.1. **Excessive Convexity.** Reduce to size by grinding off the excess weld metal, leaving a smooth profile.
- 4.3.8.2. **Shrinkage Cracks, Cracks in Base Metal, Craters, and Excessive Porosity.** Remove defective portions of base and weld metal down to sound metal, and replace with additional sound weld metal.

- 4.3.8.3. **Undercut, Undersize, and Excessive Concavity.** Clean and deposit additional weld metal.
- 4.3.8.4. **Overlap and Incomplete Fusion.** Remove and replace the defective portion of weld.
- 4.3.8.5. **Slag Inclusions.** Remove the parts of the weld containing slag, and replace them with sound weld metal.
- 4.3.8.6. **Removal of Base Metal during Welding.** Clean and form full size by depositing additional weld metal using stringer beads.
- 4.4. **Shear Stud Welding.** Weld shear studs to steel surfaces and perform preproduction and production tests as required in AASHTO/AWS D1.5.
- 4.5. **Welding Reinforcing Steel.** Splice reinforcing steel by welding only at locations shown on the plans.
- 4.5.1. **Base Metal.** Provide weldable reinforcing steel in conformance with Item 440, "Reinforcement for Concrete."
- 4.5.2. **Preheat and Interpass Temperature.** Minimum preheat and interpass temperatures are shown in Table 5. Preheat reinforcing steel when it is below the listed temperature for the size and carbon equivalency range of the bar being welded so that the cross-section of the bar is above the minimum temperature for at least 6 in. on each side of the joint. Allow bars to cool naturally to ambient temperature after welding is complete. Do not accelerate cooling.

Table 5
Minimum Preheat and Interpass Temperature for Reinforcing Steel

Carbon Equivalent Range (%)	Size of Reinforcing Bar (no.)	Temperature (°F)
Up to and including 0.40	Up to 11 inclusive	None
	14 and 18	50
0.41 through 0.45 inclusive	Up to 11 inclusive	None
	14 and 18	100
0.46 through 0.55 inclusive	Up to 6 inclusive	None
	7 to 11 inclusive	50
	14 and 18	200
Unknown	Up to 18 inclusive	500

Base the preheat and interpass temperatures for widening projects on the existing reinforcing steel and the requirements of Table 5.

- 4.5.3. **Joint Types.** Use butt splices for all No. 7 and larger bars. Use lap splices for No. 6 and smaller bars.

Make groove welds in lap splices at least 4 in. long, and weld them on each side of the lap joint as shown in Figure 7. For No. 5 and smaller bars, weld from one side of the lap when it is impractical to weld from both sides of the joint if approved by the Engineer, but in this case make the weld at least 6 in. long.

Make all butt splices in the flat position. Make all welds for butt splices, except horizontal welds on vertical bars, as shown in Figures 8 and 9. The back-up strip is required when access to the splice is from the top only. When bars can be rotated or access to the splice is available from 2 sides, the double bevel splice may be used, and this type weld requires gouging out the root pass similar to a flange splice on structural steel. The root pass may be made using E7010 or E8010 electrodes for all double beveled splices. Preheat the steel to 400°F, if using E7010 or E8010 electrodes, and then completely remove the root pass before welding the opposite side. Make horizontal splices on vertical bars as shown in Figure 10. Provide alignment strips as shown in Figures 9 and 10 to hold bars during welding operation. Trim alignment strips after welding is complete.

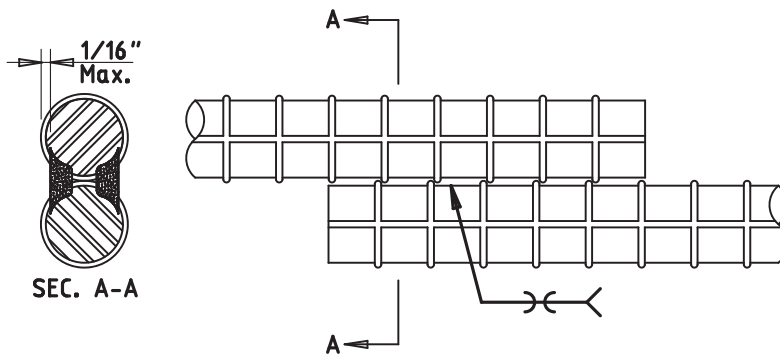

Figure 7
Direct Lap Joint with Bars in Contact

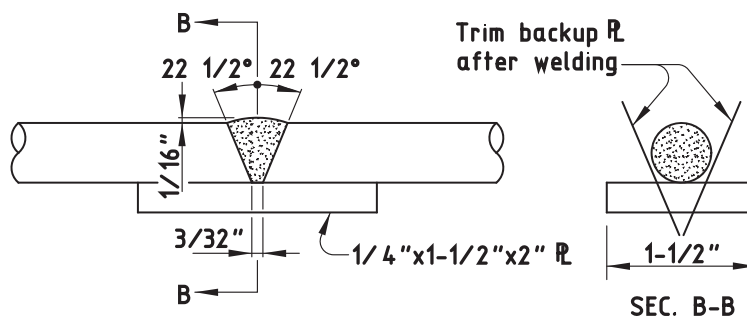

Figure 8
Single Bevel V-Groove Weld in Horizontal Position

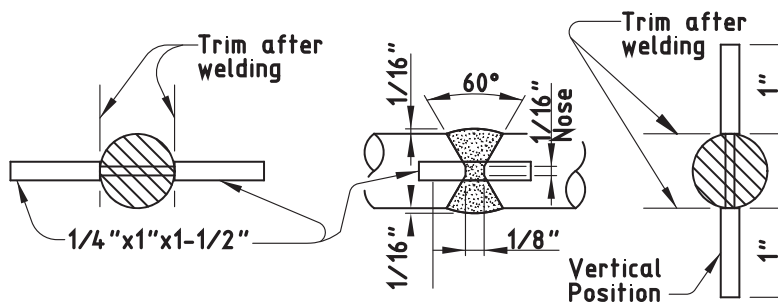

Figure 9
Double Bevel V-Groove Weld in Horizontal Position

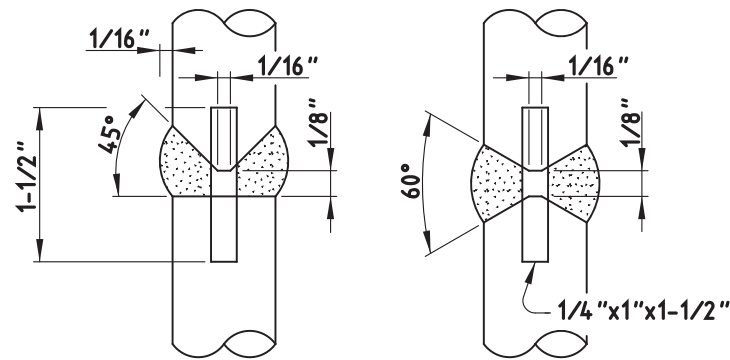

Figure 10
Double Bevel V-Groove Weld in Vertical Position

- 4.5.4. **Radiographic Inspection.** Radiograph welded butt splices at the expense of the Contractor when designated on the plans. Follow all applicable rules and regulations for radiographic operations. Ensure welds have no cracks and that the sum of the greatest dimensions of porosity and fusion-type defects do not exceed 1/10 of the nominal bar diameter.

The Engineer will examine and interpret the resulting radiographs, which become the property of the Department and remain with the Engineer.

5. MEASUREMENT AND PAYMENT

The work performed, materials furnished, equipment, labor, tools, and incidentals will not be measured or paid for directly but will be subsidiary to pertinent Items.

Item 449

Anchor Bolts



1. DESCRIPTION

Fabricate and install anchor bolts to be embedded in or attached to concrete. Anchor bolts are also referred as anchor rods.

2. MATERIALS

- 2.1. **Bolts and Nuts.** Provide bolts and nuts that meet the standards given in Table 1.

Table 1
Bolt and Nut Standards

Specified Anchor Bolt Category	Bolt Standards	Nut Standards
Mild steel	ASTM A307 Gr. A, F1554 Gr. 36, or A36	ASTM A563
Medium-strength, mild steel	ASTM F1554 Gr. 55 with supplementary requirement S1	ASTM A194 Gr. 2 or A563 Gr. D or better
High-strength steel	ASTM A325 or A449 ¹	ASTM A194 or A563, heavy hex
Alloy steel	ASTM A193 Gr. B7 or F1554 Gr. 105	ASTM A194 Gr. 2H or A563 Gr. DH, heavy hex

1. If headed bolts are specified, ASTM A449 bolts must be heavy hex head.

Provide a mill test report or manufacturer's certification indicating the material conforms to these requirements. For alloy steel anchor bolts, provide a test report or certification attesting to the heat-treating process if applicable. If no specific bolt category is indicated on the plans, provide mild steel anchor bolts and nuts that meet the standards given in Table 1.

- 2.2. **Washers.** Use washers that meet ASTM F436.

- 2.3. **Threads.** Provide anchor bolts with rolled or cut threads of UNC or 8UN series in accordance with ASME B1.1. Anchor bolts 1-3/4 in. in diameter and larger must have UNC series threads. If bolts have rolled threads, ensure the diameter of the unthreaded portion of bolts with rolled threads is neither less than the minimum pitch diameter nor more than the maximum major diameter of the threads. If bolts have cut threads, ensure the diameter of the unthreaded portion is not less than the minimum major diameter of the threads. Ensure all threads for bolts and nuts have Class 2 fit tolerances in accordance with ASME B1.1.

3. CONSTRUCTION

- 3.1. **Fabrication.** Welded splicing of anchor bolts is not permitted.

Provide an anchorage device with each anchor bolt consisting of a standard bolt head, a threaded bolt with nuts, or, if shown on the plans, a 90° bend. Make the inside-bend diameter approximately 2 times the anchor bolt diameter, but at no point along the bend greater than 3 times the bolt diameter. Hot bending is permissible provided the temperature does not exceed 1,100°F.

If the anchor bolts will be installed in a template embedded in concrete, tack weld the anchorage nuts to the template in the shop. Perform this welding with appropriate jigs to ensure the anchor bolt is perpendicular to the template.

When embedded templates are not specified and nuts are welded to the end of anchor bolts for anchorage, weld only on the nut face at the unstressed end of the bolt. Ensure no welding, arc, or other potential notch-producing effects occur in the stressed portion of the bolt.

Shipping of the anchor bolt cage in its assembled condition is not required.

- 3.2. **Finish.** Galvanize in accordance with Item 445, "Galvanizing."
- 3.2.1. **Anchor Bolts Embedded in Concrete.** Galvanize the exposed end of the thread length plus a minimum of 6 in. unless otherwise shown on the plans.
- 3.2.2. **Anchor Bolts Extending Through Concrete.** Galvanize the complete length of the bolt.
- 3.2.3. **Nuts.** Galvanize exposed nuts. Galvanize the untapped blanks before cutting the threads.
- 3.2.4. **Washers.** Galvanize exposed washers.
- 3.3. **Installation.** Hold the anchor bolt and template assembly rigidly in position during concrete placement. Use wood templates or other positive means to ensure correct positioning of anchor bolts not requiring steel templates. Positioning devices may be tack welded to the steel templates but not to any portion of the anchor bolts.
- 3.3.1. **Anchor Bolt Thread Lubricant Coating.** Coat anchor bolt threads before installing nuts with an electrically conducting lubricant compound described in Section 449.3.3.2.1., "Definitions," for traffic signal poles, roadway illumination poles, high mast illumination poles, and overhead sign support structures. Coat anchor bolt threads for other structures with pipe joint compound or beeswax. After installing nuts, repair galvanizing damage on bolts, nuts, and washers in accordance with Section 445.3.5., "Repairs."
- 3.3.2. **Anchor Bolt Tightening Procedure.** Tighten anchor bolts for traffic signal poles, shoe base and concrete traffic barrier base roadway illumination poles, high mast illumination poles, and overhead sign support structures in accordance with this Section. This procedure covers the tightening of nuts on a double-nut anchor bolt system using anchor bolts with 55 ksi or 105 ksi minimum yield strength and UNC or 8UN thread series to secure structures to drilled shaft foundations.
- 3.3.2.1. **Definitions.** The following definitions apply to the anchor bolt tightening procedure:
- **Double-Nut Anchor Bolt System.** An anchor bolt with 2 nuts that sandwich the structure's base plate. The bottom nut is positioned under the base plate to level, support, and provide the reaction for the force applied by tightening the top nut positioned above the base plate.
 - **Electrically Conducting Lubricant.** A compound commonly used in the electrical industry to coat threads of field-cut rigid metal conduit and suitable for exposure to weather.
 - **Impact Tightening.** The tightening of nuts with a box end "slug" or "knocker" wrench and a sledgehammer. The wrench, matching the size of the nut to be tightened, is driven with the sledgehammer to rotate the nut.
 - **Static Tightening.** The tightening of nuts with a "spud" wrench and a pipe or extension handle. The wrench, matching the size of the nut to be tightened, may be turned with more than one worker to rotate the nut.
 - **Snug-Tight.** The condition when the nut is in full contact with the base plate. It may be assumed the full effort of a worker on a 12-in. wrench results in a snug-tight condition.
 - **Turn-of-the-Nut Method.** The tightening of top nuts to snug-tight condition then establishing reference positions by marking one flat on each nut with a corresponding reference mark on the base plate at each bolt. Each nut is then turned to the prescribed rotation from the referenced snug-tight position.
- 3.3.2.2. **Anchor Bolt Tightening.** Perform the following procedure:
- Coat the threads of the anchor bolts with electrically conducting lubricant.

- Install the bottom nuts on the bolts, 1 on each bolt.
- Level the top template (using it as a guide) by adjusting the bottom nuts so the template rests on each nut and the distance between the top of the concrete shaft and the bottom surface of the bottom nut is approximately 1/2 in.
- Remove the template.
- Coat the bearing surfaces of the bottom nuts and washers with electrically conducting lubricant.
- Install bottom washers on bolts, 1 on each bolt.
- Erect and plumb the structure as specified. Adjust the bottom nuts so each is bearing equally on the washer or base plate. The truss for cantilever overhead sign support structures and the mast arm for traffic signal poles must be removed during anchor bolt tightening.
- With the plumbed structure supported by a crane, coat the bearing surfaces of the top nuts and washers with electrically conducting lubricant. Install 1 washer and 1 top nut on each bolt. Turn the top nuts onto the bolts so each is hand-tight against the washer or base plate.
- Turn each bottom nut to a snug-tight condition using a wrench.
- Verify the structure is still plumb and still supported by the crane. Begin turn-of-the-nut method by turning each top nut down to the same snug-tight condition. Prevent rotation of the bottom leveling nut during all top nut tightening. Establish reference marks for turn-of-the-nut method once snug-tight condition is achieved, and then tighten the top nuts by turning each nut 1/12 turn (1/2 of a nut flat) past snug-tight using either static or impact tightening. Turn each top nut an additional 1/12 turn until each nut has been tightened 1/6 total turn past snug-tight.

4.**MEASUREMENT AND PAYMENT**

Top or bottom templates, washers, lock washers, nuts, lock nuts, and other devices used for installing anchor bolts are considered part of the anchor bolt assembly. All work performed, materials furnished, equipment, labor, tools, and incidentals will not be measured or paid for directly but will be subsidiary to pertinent Items.

Item 450

Railing



1. DESCRIPTION

Construct railing of concrete, steel, aluminum, or a combination of these materials, including necessary anchorage for the railing on bridges, culverts, walls, or other structures as shown on the plans.

2. MATERIALS

Use materials that conform to requirements of the following Items.

- Item 421, "Hydraulic Cement Concrete,"
- Item 440, "Reinforcement for Concrete,"
- Item 441, "Steel Structures,"
- Item 442, "Metal for Structures,"
- Item 445, "Galvanizing," and
- Item 540, "Metal Beam Guard Fence."

Provide an approved Type III, Class C epoxy or an epoxy of the type and class stated on the plans where epoxy anchors are allowed or required for installing drilled and epoxied rail anchorage reinforcement or rail anchor bolts in accordance with DMS-6100, "Epoxyes and Adhesives." Use other materials if shown on the plans. Provide only dual cartridge epoxy systems mixed with a static mixing nozzle supplied by the epoxy adhesive manufacturer and dispensed with a tool supplied by the epoxy adhesive manufacturer. Do not use bulk epoxyes. Drill and install anchorage reinforcement or anchor bolts to the embedment depth shown on the plans or the depth the manufacturer recommends, whichever is deeper. No additional payment will be made for providing embedment deeper than shown on the plans. Select an embedment depth capable of developing the yield strength of the steel anchor based on the product literature for the epoxy and steel anchor being used if no resistance or embedment depth is specified on the plans. Use 60 ksi as the yield strength for reinforcing steel.

3. CONSTRUCTION

Construct railing in accordance with details, alignment, and grade designated on the plans. Do not place railing until falsework or formwork, if any, for the span has been released unless otherwise directed. Adhere to the schedule restrictions for Placing Bridge Rails and Opening to Construction Traffic in Item 422, "Concrete Superstructures." Notify the Engineer after completion of the following steps and obtain approval of work before proceeding to the next step: placing rail reinforcement and pre-pour clear cover checks.

Ensure expansion joints in the railing will function properly before placing concrete.

Furnish either steel or aluminum, but not both, for the entire Contract if the plans allow either steel or aluminum options for a particular railing type.

Install epoxy adhesive anchorages in accordance with the manufacturer's instructions including hole size, drilling equipment and method, hole cleaning equipment and method, mixing and dispensing epoxy, and anchor insertion. Do not alter the manufacturer's mixing nozzle or dispenser. Anchorage bars or bolts must be clean and free of grease, oil, or any other foreign material. Demonstrate hole cleaning method to the Engineer for approval and continue the approved process for all anchorage locations. Do not weld to an anchor bar or anchor bolt that is anchored with epoxy adhesive. Do not expose rail to traffic until epoxy adhesive has obtained full cure in accordance with manufacturer's specifications.

3.1. **Metal Railing.**

3.1.1. **General.** Furnish metal beam rail elements in accordance with Item 540, "Metal Beam Guard Fence."

Fabricate and erect metal railing according to the pertinent provisions of Item 441, "Steel Structures," and the requirements of this Item.

Prepare and submit for approval the required shop or erection drawings in accordance with Item 441, "Steel Structures," when the plans require. Show all splice locations and details on the shop or erection drawings. Splice members only as provided on the plans.

Field-weld when required in accordance with Item 448, "Structural Field Welding."

3.1.2. **Fabrication.** Fabricate metal railing and post panels in sections conforming to the details shown on the plans and field-verified lines and grades. Fabricate adjacent sections so they will accurately engage each other in the field. Match-mark each pair of sections so they can be erected in the same position they were fabricated.

Fabricate metal rail elements included as part of the railing system to the dimensions and cross-sections shown on the plans and within a tolerance of 1/4 in. per 10 feet in the straightness of either edge. Joint and connect metal rail elements to the rail posts as shown on the plans, lapping metal rail elements in the direction of traffic in the adjacent lane. Bolts and nuts for metal railing should meet requirements of ASTM A307 and be galvanized in accordance with Item 445, "Galvanizing," unless otherwise shown on the plans.

Fabricate aluminum in accordance with AWS D1.2.

Heat aluminum materials other than castings to a temperature up to 400°F for no more than 30 min. to facilitate bending or straightening.

3.1.3. **Castings.** Provide permanent mold castings of the materials specified that are true to pattern in form and dimensions and of uniform quality and condition. Castings must be free from cracks and defects such as blowholes, porosity, hard-spots, or shrinkage that could affect their suitability for use. Repair minor defects in aluminum castings by an approved inert gas-welding process. Ensure finished castings are free of burrs, fins, discoloration, and mold marks and that they have a uniform appearance and texture.

Produce castings under radiographic control sufficient to establish and verify a product free from harmful internal defects. Heat-treat the entire lot of castings to the specified temper when required.

Permanently mark the heat or lot number on the web or top of the base of all castings. Furnish mill test reports showing the heat or lot number, chemical composition, tensile strength, elongation, and number of pieces for each casting heat or lot. For aluminum castings, a heat or lot should consist of at least 1,000 lb. of trimmed castings when produced from batch type furnaces, or 2,000 lb. when produced from a continuous furnace during a period of no more than 8 consecutive hours. Furnish the entire number of acceptable posts cast from each heat or lot except when a portion is required to complete a project.

3.1.4. **Corrosion Protection.** Galvanize all portions of steel railing after fabrication in accordance with Item 445, "Galvanizing," unless otherwise noted on the plans. Apply appearance coat to galvanized surface in accordance with Item 445, "Galvanizing," when shown on the plans. When painting is specified in place of galvanizing, shop paint steel in accordance with Item 441, "Steel Structures." Repair any damage to galvanized or painted surfaces after erection in accordance with Items 445, "Galvanizing," and Item 446, "Field Cleaning and Painting Steel," respectively.

Before final acceptance, clean surfaces of aluminum and galvanized steel railing not shown to be painted to remove extrusion marks, grease, dirt, and all other surface contaminants.

3.1.5. **Storage.** Store railing materials above the ground on platforms, skids, or other supports, and keep them free from grease, dirt, and contact with dissimilar metals. Avoid scratching, marring, denting, discoloring, or otherwise damaging the railing.

3.2. **Concrete Railing.** Provide concrete portions of railing in accordance with the requirements of Item 420, "Concrete Substructures," and Item 422, "Concrete Superstructures." Construct forms so the railing line and grade can be checked after the concrete has been placed but before initial set. Do not disturb the form alignment during finish floating of the railing tops. Exercise particular care in other construction to avoid disturbing or vibrating the span with the newly placed railing.

Provide precast members conforming to Item 424, "Precast Concrete Structural Members (Fabrication)."

Slipform construction of railing is permitted unless otherwise shown on the plans. Demonstrate slipforming method showing line and grade of concrete surfaces can be consistently obtained and clear cover outside reinforcing steel be maintained at all times. Stop slipforming railing if specified concrete clear cover is not obtained or appearance of rail is off line and grade.

Do not slipform railing with cast-in-place anchor bolts unless noted otherwise.

Provide additional reinforcing as needed to prevent movement of the reinforcement cage. Clear cover and epoxy coating requirements for additional reinforcement are the same as shown for the rail reinforcement. The rail reinforcing cage may be tack welded to the rail anchorage reinforcement provided the rail and anchorage reinforcement are not epoxy coated and weld locations measured along the rail are no closer than 3 ft. Tie all bar intersections if epoxy coated reinforcement is required for the railing proposed to be slipformed. Provide a wire line to maintain vertical and horizontal alignment of the slipform machine. Attach a grade line gauge or pointer to the machine so a continuous comparison can be made between the rail being placed and the established grade line. Rails or supports at the required grade are allowed instead of sensor controls. Make one or more passes with the slipform over the rail segment to ensure proper operation and maintenance of grades and clearances before placing concrete. Provide slipformed rail within a vertical and horizontal alignment tolerance of $\pm 1/4$ in. per 10 feet. Construct rail with a smooth and uniform appearance. Consolidate concrete so it is free of honeycomb. Provide concrete with a consistency that will maintain the shape of the rail without support. Minimize starting and stopping of the slipform operation by ensuring a continuous supply of concrete.

Do not exceed the manufacturer's recommended speed for the slipform machine. Stop slipforming and take remedial action if slipforming causes movement of the reinforcement such that plan clearances are not achieved. Remove and replace unsatisfactory slipformed rail at the Contractor's expense.

3.3. **Tests.** The Engineer will sample cast aluminum posts for testing in accordance with Tex-731-I to verify the material requirements of Item 442, "Metal for Structures." Metal beam rail elements may be sampled in accordance with Tex-713-I. The Engineer may sample bolts and nuts in accordance with Tex-708-I for galvanized coating testing.

The Engineer will select 3 anchor bars or bolts from the first day's production to be tested after the epoxy has cured. Test the bars or bolts in the presence of the Engineer in accordance with ASTM E1512, using a restrained test, to evaluate the epoxy adhesive's bond strength. Verify the anchor bars or bolts develop the required pullout resistance on the plans or 75% of the yield strength of the bars or bolts, whichever is less, without a bond failure of the epoxy. The Engineer may require additional tests during production. Perform corrective measures to provide adequate capacity if any of the tests do not meet the required test load. Repair damage from testing.

4. MEASUREMENT

This Item will be measured by the foot.

This is a plans quantity measurement Item. The quantity to be paid for is the quantity shown in the proposal except as modified by Article 9.2., "Plans Quantity Measurement." Additional measurements or calculations will be made if adjustments of quantities are required.

5. PAYMENT

The work performed and materials furnished in accordance with this Item and measured as provided under "Measurement" will be paid for at the unit price bid for "Railing" of the type specified. This price will be full compensation for furnishing, preparing, and placing concrete, expansion joint material, reinforcing steel, structural steel, aluminum, cast steel, pipe, anchor bolts or bars, testing of epoxy anchors, and all other materials required in the finished railing; removal and disposal of salvageable materials; and hardware, paint and painting of metal railing, galvanizing, equipment, labor, tools, and incidentals.

Item 451

Retrofit Railing



1. DESCRIPTION

Retrofit or replace railing.

2. MATERIALS

Use materials that conform to requirements of the following Items.

- Item 421, "Hydraulic Cement Concrete,"
- Item 440, "Reinforcement for Concrete,"
- Item 441, "Steel Structures,"
- Item 442, "Metal for Structures,"
- Item 445, "Galvanizing," and
- Item 540, "Metal Beam Guard Fence."

3. CONSTRUCTION

Remove existing railing to the lines and grades shown on the plans. Do not damage any portion of the structure that is to remain in place. Replace any concrete removed beyond the neat lines or other established lines at the Contractor's expense. Remove bolts to disassemble steel members unless otherwise approved. Incorporate reinforcing steel into the new concrete railing with at least 1-1/2 in. of clear cover if indicated on the plans. Cut off existing reinforcing steel at least 1 in. below the finished surface of the concrete if it cannot be reused as dowels. Repair as directed any concrete damaged from making the cut-off. Refinish the top of the concrete slab where the railing is removed, but not replaced, to leave a neat surface as specified on the plans and in accordance with Item 429, "Concrete Structure Repair."

Dispose of removed material off the right of way in accordance with federal, state, and local regulations, unless otherwise shown on the plans. Carefully dismantle rail by unbolting steel members when plans specify to salvage rail members. Deliver materials to be retained by the Department to the location shown on the plans. Block up salvaged steel materials off the ground.

Construct replacement railing in accordance with Item 450, "Railing."

4. MEASUREMENT

This Item will be measured by the foot.

This is a plans quantity measurement Item. The quantity to be paid for is the quantity shown in the proposal except as modified by Article 9.2., "Plans Quantity Measurement." Additional measurements or calculations will be made if adjustments of quantities are required.

5. PAYMENT

The work performed and materials furnished in accordance with this Item and measured as provided under "Measurement" will be paid for at the unit price bid for "Retrofit Railing" of the type specified. This price will be full compensation for removal and disposal of existing railing, disassembling and delivering members to be retained by the Department, repairing damaged bridge deck, furnishing, preparing, and placing concrete, expansion joint material, reinforcing steel, structural steel, aluminum, cast steel, pipe, anchor bolts or bars,

testing of epoxy anchors, and all other materials required in the finished railing; and hardware, paint and painting of metal railing, galvanizing, equipment, labor, tools, and incidentals.

Item 454

Bridge Expansion Joints



1. DESCRIPTION

Furnish and install bridge expansion joints.

2. MATERIALS

Provide materials in accordance with the requirements of the following Items.

- Item 442, "Metal for Structures,"
- DMS-6140, "Polymer Concrete for Bridge Joint Systems,"
- DMS-6310, "Joint Sealants and Fillers," and
- ASTM D5973.

Use primers recommended by the manufacturer of the sealant when required. Use backer rods compatible with the sealant that do not react or bond together.

3. CONSTRUCTION

Place expansion joints to conform to the finished grade of the roadway surface. Set the joint opening at the dimension shown on the plans for 70°F, adjusted for the temperature at the time of installation. Place the seal for the full length of the joint for sealed joint openings and, when required, extend it into the parapet wall on the low side or sides of the bridge.

- 3.1. **Sealed Expansion Joint (SEJ).** Choose an approved joint system that conforms to the joint type and the design requirements shown on the plans. Secure each side of the joint by welding it to the adjacent reinforcing steel or other attachments as approved. Remove any connection holding the joint halves together immediately after each joint half is secured in place. Install the neoprene seal as a continuous piece to form a watertight seal.
- 3.2. **Armor Joint.** Place steel armor plates as shown on the plans. Secure each side of the joint by welding it to adjacent reinforcing steel or other attachments as approved. Remove any connection holding joint halves together immediately after each joint half is secured in place.
- Seal the joint when specified. Abrasive blast clean the vertical faces of the steel plates where the sealant will be in contact to remove all visible rust, paint, mill scale, and other forms of contamination, leaving a white metal appearance. Clean the concrete in contact with the sealant by an approved method in accordance with the manufacturer's specifications before placing sealant. After cleaning, air blast the joint to remove all dust. Place sealant in accordance with the manufacturer's specifications and as shown on the plans. Repair damage to paint protection system above the seal when shown on the plans for steel armor plates to be painted.
- 3.3. **Header-Type Expansion Joint.** Meet with the manufacturer's representative and the Engineer to discuss the required installation procedures of the materials before beginning the work. Perform the work in accordance with the manufacturer's printed instructions and as discussed in the meeting. Additionally, the Engineer may request the presence of the manufacturer's representative for additional training if work personnel are not adequately following manufacturer's installation directions.
- 3.3.1. **Header.** Provide an approved polymer concrete from DMS-6140, "Polymer Concrete for Bridge Joint Systems." Create the required void in the concrete surface or asphalt overlay to accept the header material

in accordance with the details shown on the plans. Extend the depth of the void in the asphalt overlay to sound concrete. Remove any unsound steel or concrete and repair concrete in accordance with Item 429, "Concrete Structure Repair," and Item 785, "Bridge Joint Repair or Replacement." Use header material as repair material only when approved. Clean the voided region of all materials that could inhibit the bond between the header material and concrete or steel. Form the joint opening to the required width shown on the plans.

Place materials once approved. Place material on a clean, sound, and dry base when the ambient temperature is at least 45°F and rising or as required by the manufacturer. Do not place material on wet substrate or when raining.

Cure for the duration required by the manufacturer's data sheets before opening to traffic.

Tool or grind the upper corner of the header adjacent to the opening to a 1/4-in. radius.

- 3.3.2. **Sealant.** Provide an approved Class 1 or Class 7 joint sealant from DMS-6310, "Joint Sealants and Fillers" unless otherwise shown on the plans. Clean the joint opening of forming material, existing seal, and other material that will inhibit the bond between the header material and the sealant. Abrasive blast clean surfaces in contact with the sealant. Place an approved backer rod and the sealant as shown on the plans. Place sealant primer and sealant when ambient temperature is rising and is between 55°F and 85°F to provide for adequate joint opening and compression of the sealant during curing.

4. MEASUREMENT

Sealed expansion joints and armor joints will be measured by the foot. Header-type expansion joints will be measured by the foot or by the cubic foot of header material and foot of sealant. Length measurement will be along the centerline of the joint at the surface of the roadway and up into the parapet. Calculate volume for header-type expansion joints using the length and width shown on the plans and the header depth measured in place.

Sealed expansion joints and armor joints are a plans quantity measurement item. The quantity to be paid is the quantity shown in the proposal unless modified by Article 9.2., "Plans Quantity Measurement." Additional measurements or calculations will be made if adjustments of quantities are required.

5. PAYMENT

The work performed and materials furnished in accordance with this item and measured as provided under "Measurement" will be paid for at the unit price bid for "Sealed Expansion Joint" of the size (minimum total movement capacity) and designation specified, "Armor Joint," "Armor Joint (With Seal)," and "Header-Type Expansion Joint." Sealing the joint will be subsidiary to these items with the exception of the header-type expansion joint when the header is paid for by volume measurement. This price is full compensation for furnishing and installing the joint systems including steel; and for materials, tools, equipment, labor, and incidentals.

If volume measurement for the header material is specified, the header material will be paid for at the unit price bid for "Header-Type Expansion Joint" and the sealant will be paid for at the unit price bid for "Joint Sealant." This price is full compensation for furnishing and installing the joint systems and for materials, tools, equipment, labor, and incidentals.

Item 458

Waterproofing Membranes for Structures



1. DESCRIPTION

Furnish and place waterproofing membranes on concrete and steel bridge decks of railroad and other types of structures.

2. MATERIALS

2.1. **Materials to be Furnished.** Furnish waterproofing materials listed below in accordance with DMS-6300, "Waterproofing":

- asphalt for mopping above ground,
- asphalt for mopping below ground,
- asphaltic primer,
- treated cotton fabric,
- self-adhering polyethylene,
- coal-tar-modified urethane,
- rubberized asphalt with preformed board membrane,
- asphalt plank,
- asphalt mat,
- rubberized asphalt with plastic film,
- asphaltic panels,
- plastic cement, and
- cold asphalt base emulsion.

Furnish butyl rubber membrane and ethylene-propylene-diene terpolymer (EPDM) sheeting in accordance with ASTM D6134.

Deliver materials requiring sampling and testing to the worksite a minimum of 3 weeks before use. Test and obtain approval for waterproofing materials before delivery to the worksite when authorized.

2.2. **Types.** Provide the following types of waterproofing as shown on the plans or as directed.

2.2.1. **Type 1.** Butyl rubber membrane applied to a surface with a proper adhesive without protective planking and in accordance with the details shown on the plans. Provide a minimum thickness of 1/16 in. unless otherwise shown on the plans.

2.2.2. **Type 2.** A single asphaltic primer coat and 1 mopping of asphalt.

2.2.3. **Type 3.** A single asphaltic primer coat and 2 moppings of asphalt. Supplement with 2 layers of treated cotton fabric with a third mopping of asphalt placed over the outer layer of fabric at construction joints of foundation structures when shown on the plans.

2.2.4. **Type 4.** Self-adhering polyethylene with a rubberized asphalt mastic material.

2.2.5. **Type 5.** Single-component, coal-tar-modified urethane coating.

2.2.6. **Type 6.** Self-adhering built-up membrane of rubberized asphalt formed on a preformed board with cold-applied asphaltic primer.

- 2.2.7. **Type 10.** Any of Type 1, Type 4, Type 5, or Type 6 waterproofing.
- 2.2.8. **Type RR-1.** Butyl rubber or EPDM membrane with a protective course of asphalt plank or asphalt mat of the specified thickness, as specified on the plans.

3. CONSTRUCTION

- 3.1. **General.** Store waterproofing material in a manner that will prevent damage. Keep material dry at all times, and store in a warm area before using in cold weather and out of direct sunlight in hot weather. Store asphalt planks, asphalt mats, and asphaltic panels in a manner that will prevent warping and breaking.
- Provide a wood float finish to concrete decks and other unformed concrete surfaces to be waterproofed. Cure concrete surfaces to be waterproofed for at least 7 days before applying waterproofing, or as directed by the waterproofing materials manufacturers.
- Ensure steel or concrete deck surfaces to be waterproofed are clean, dry, smooth, and free of fins, sharp edges, and loose material. Use grinders, if necessary, to remove protrusions that would puncture waterproofing membrane. Ensure surfaces are free of contaminants such as form-release agents, wax base curing compounds, oil, and grease. Remove any contaminants by abrasive blast cleaning. Ensure there are no depressions or pockets in horizontal surfaces of finished waterproofing.
- Fill expansion joints and other grooves with plastic cement conforming to the requirements of DMS-6300, "Waterproofing," unless otherwise required on the plans. Ensure joints are dry and clean when filled. Overfill slightly to allow for shrinkage in drying.
- Sweep, vacuum, or air-blow the area to be waterproofed thoroughly to remove dust, dirt, and loose foreign material. Maintain the deck in a clean condition until completion of waterproofing.
- Do not allow vehicular or equipment traffic on the bridge after the deck waterproofing work has started or until after the work is complete, cover sheets are in place, and an adequate ballast cushion has been placed on the deck. Protect the waterproofing against damage from any source.
- Use asphalt for mopping below ground as defined in DMS-6300, "Waterproofing," when asphalt waterproofing is shown as a protection for back of abutments, retaining walls, or footings. Use asphalt for mopping above ground as defined in DMS-6300, "Waterproofing," for waterproofing on bridge decks.
- 3.2. **Type 1.** Do not apply waterproofing in wet weather or when the ambient temperature is below 50°F. Ensure the rubber membrane is free from punctures, pockets, or folds.
- Turn the membrane into drainage holes and castings without break. Take special care to make the waterproofing effective along the sides and ends of members to be waterproofed.
- Install the butyl rubber membrane by first applying the adhesive as recommended by the membrane manufacturer. Apply the adhesive to the surface to be waterproofed and at necessary splices, in a solid area extending approximately 36 in. back from the edges. Apply the membrane by pressing it firmly and uniformly in place against the previously applied adhesive, avoiding wrinkles and buckles. Make splices, laps, and flashing in accordance with the membrane manufacturer's recommended procedures.
- 3.3. **Type 2.** Place the asphalt primer at least 24 hr. before the asphalt mopping. Ensure the primer is dry before the mopping. Work in the primer to give a uniform coating. Heat the asphalt for mopping in kettles equipped with armored thermometers, but do not heat above 350°F. Stir the asphalt frequently while heating. Apply the mop coating at a rate of at least 4 gal. per 100 square feet of surface. Apply additional coatings, if imperfections appear, until corrected.
- 3.4. **Type 3.** Place the asphalt primer at least 24 hr. before the asphalt mopping. Ensure the primer is dry before the mopping. Work in the primer to give a uniform coating. Heat the asphalt for mopping in kettles equipped

with armored thermometers, but do not heat above 350°F. Stir the asphalt frequently while heating. Use a minimum coverage rate for each mop coating of 4 gal. per 100 square feet of surface. Apply additional coatings, if imperfections appear, until corrected.

Mop the surfaces to be waterproofed in sections at construction joints. Lay a 15-in. wide strip of cotton fabric on the first mopping while the asphalt is still hot and press into place. Apply subsequent moppings to completely cover and seal the cotton fabric. Make the end laps of the cotton fabric at least 12 in. unless otherwise shown on the plans.

- 3.5. **Type 4.** Unwrap the roll of waterproofing and press the adhesive surface into contact with the concrete horizontally. Secure the free end and then unroll slowly, using hand pressure to smooth the membrane into place and help make a tight bond with the concrete. Overlap adjacent strips a minimum of 1 in. over the previously laid strip. Backfilling may be started as soon as the initial horizontal strip has been applied.
- 3.6. **Type 5.** Apply waterproofing in 2 coats to produce a minimum cured film thickness of 1/16 in. Apply using a roller, squeegee, brush, or spray equipment unless otherwise shown on the plans. Apply the second coat within 16 hr. after the initial coat. Follow the manufacturer's instructions with regard to the maximum time allowed between coats and any treatment of the initial coat required if this maximum time is exceeded. The minimum ambient temperature at the time of waterproofing application is 40°F. Do not begin backfilling until the second coat of waterproofing has cured sufficiently to prevent damage by the backfilling operation.
- 3.7. **Type 6.** Apply the primer at a rate of 1 gal. per 100 square feet of surface or at the rate recommended by the manufacturer if different. Allow to dry to a tacky surface before placing the waterproofing membrane. Apply the primer and waterproofing membrane board panels only when the substrate temperature is above 50°F.

Seal joints by centering 6-in. gusset tape over the joint and pressing firmly into position. Roll in the panels and jointing tape with sufficient pressure to assure maximum adhesion, conformance to substrate, and elimination of air bubbles. Follow the manufacturer's recommendations for installation.

Begin backfilling as soon as the application of the waterproofing is complete. Complete backfilling within 48 hr. after the waterproofing material is applied to a non-horizontal surface.

- 3.8. **Type RR-1.** Apply waterproofing to dry surfaces and only when the ambient temperature is above 50°F. Ensure the butyl rubber or EPDM membrane is free from punctures, pockets, or folds. Turn the membrane into drainage castings without break. Take special care to make the waterproofing effective along the sides and ends of girders and at stiffeners, gussets, etc. Fill grooves with plastic cement.

Install the butyl rubber or EPDM membrane by first applying the adhesive as recommended by the membrane manufacturer to ballast retainers, ends of deck, and at necessary splices in a solid area extending from the edges back about 36 in. or as shown on the plans. Apply the membrane and press it firmly and uniformly in place against the previously applied adhesive, avoiding wrinkles and buckles. Make splices, laps, and flashing in accordance with the membrane manufacturer's recommended procedures.

Place the protective cover as soon as practicable after placement of the membrane. Clean the membrane surface of dirt and other foreign material before placing the cover material. Apply a coating of cold asphalt emulsion over the membrane at a minimum rate of 4 gal. per 100 square feet of surface. Place the asphalt plank or mat on the coating of cold asphalt emulsion.

Provide a minimum thickness of protection of 1 in., consisting of asphalt plank or asphalt mat unless otherwise specified on the plans. Coat the edges and ends of adjacent planks already laid with cold asphalt emulsion as successive planks are laid. Lay the planks tightly against those previously laid so the emulsion will completely fill the joints and be squeezed out the top. Fill any joints not completely full after planks have been laid with emulsion. Offset the vertical joints of the second layer at least 4 in. transversely and 1 ft. longitudinally from the joints in the lower layer when 2 layers of planks are used to obtain the required 1-in. cover thickness.

Apply asphalt mat protection in the same manner except stagger the longitudinal butt joints in a single layer by approximately 2 ft. Follow the same procedure with all vertical joints offset by at least 1 ft. when more than 1 thickness of asphalt mat is required Place a follow-up coating of asphalt emulsion approximately 6 in. wide over all joints of the top layer.

Use asphalt for mopping above ground as defined in DMS-6300, "Waterproofing," where deck waterproofing is carried over the back wall and down the back of the abutment for only several feet to provide a proper flashing for the deck waterproofing.

4. MEASUREMENT

When waterproofing is shown on the plans to be a pay item, measurement will be by the square yard.

5. PAYMENT

Unless otherwise specified on the plans, the work performed, materials furnished, equipment, labor, tools, and incidentals will not be paid for directly but will be considered subsidiary to pertinent Items.

When waterproofing is specified as a pay item, the work performed and materials furnished in accordance with this Item and measured as provided under "Measurement" will be paid for at the unit price bid for "Waterproofing," of the type specified. This price is full compensation for materials furnished, equipment, labor, tools, and incidentals.

Item 459

Gabions and Gabion Mattresses



1. DESCRIPTION

Furnish and install gabions and gabion mattresses.

2. MATERIALS

This Item uses the following Items:

- **Gabion.** A wire fabric or mesh container, filled with stone, with a height of 1 ft. or greater.
- **Gabion Mattress.** A wire fabric or mesh container filled with stone and with a height of 6, 9, or 12 in. Referred to as “revet mattress” in ASTM A975.

Furnish welded wire gabions and gabion mattresses in accordance with ASTM A974. Furnish Style 1 or 2 when galvanized wire coating is specified or Style 5 when PVC wire coating is specified.

Furnish twisted wire gabions and gabion mattresses in accordance with ASTM A975. Furnish Style 1 when galvanized wire coating is specified or Style 3 when PVC wire coating is specified.

Furnish producer or supplier certification that wire baskets, stiffeners, lacing wire, and spiral connectors conform to the applicable ASTM specification.

Furnish producer or supplier certification that any alternative wire fasteners that are proposed conform to the strength requirements in Table 1 when tested in accordance with the applicable ASTM specification. Submit certification for approval before beginning work.

Table 1
Minimum Panel-to-Panel Connection Strength

Application	Strength (lb./ft.)
Gabions, galvanized	1,400
Gabions, PVC-coated	1,200
Gabion mattress, galvanized and PVC-coated	700

Provide filler stone consisting of clean, hard, durable stone that does not contain shale, caliche, or other soft particles. Stone appearing to contain such particles will be tested for soundness. Stone with 5-cycle magnesium sulfate soundness of more than 18% when tested in accordance with Tex-411-A will be rejected. Use stones that are between 4 and 8 in. in their least dimension for gabions and between 3 and 6 in. for gabion mattresses. Prevent contamination when storing and handling stone. Use stone with a minimum bulk specific gravity of 2.50 as determined by Tex-403-A.

Provide Type 2 filter fabric when required in accordance with DMS-6200, “Filter Fabric.”

Provide filter material when required consisting of hard, durable, clean sand or gravel with a maximum particle size of 3/8 in.

3. CONSTRUCTION

At the start of construction, the gabion and gabion mattress manufacturer must have a qualified representative available for consultation as needed throughout the gabion and gabion mattress construction.

- 3.1. **Foundation Preparation.** Excavate the foundation to the extent shown on the plans or as directed. Remove all loose or otherwise unsuitable materials. Carefully backfill all depressions to grade with suitable materials from adjacent required excavation or another approved source, and compact the backfill to a density at least equal to the adjacent foundation. Remove any buried debris protruding from the foundation that will impede the proper installation and final appearance of the gabion or gabion mattress, and carefully backfill and compact voids as specified above. Have the Engineer inspect the prepared foundation surface immediately before gabion placement.
- 3.2. **Filter Placement.** Spread filter material, when required, uniformly on the prepared foundation surface to the slopes, lines, and grades indicated on the plans. Do not place filter material by methods that tend to segregate particle sizes. Repair all damage to the foundation surface that occurs during filter placement before proceeding with the work. Compaction of the filter material is not required; but, finish the material to present a reasonably even surface without mounds or windrows.
- 3.3. **Filter Fabric Placement.** Place filter fabric as shown on the plans when required. Any defects, rips, holes, flaws, or damage to the material may be cause for rejection. Place the material with the long axis parallel to the centerline of the structure, highway, or dam. Place securing pins in the lapped longitudinal joints, spaced on approximately 10-ft. centers. Keep the fabric material free of tension, stress, folds, wrinkles, or creases. Lap the material at least 3 ft. along the longitudinal joint of material, or lap the joints 1 ft. and sew them. Lap the ends of rolls at joints by at least 3 ft. Repair torn or punctured fabric by placing a layer of fabric over the damaged area, overlapping at least 3 ft. beyond the damaged area in all directions.
- Place securing pins through both strips of material at lapped joints at approximately the midpoint of the overlap. Place additional securing pins as necessary to hold filter fabric in position. Store filter fabric out of direct sunlight. Cover filter fabric as soon as possible after placing, but within 3 days.
- 3.4. **Assembly and Installation.** Place PVC-coated materials, if wire coating is specified, when the ambient temperature and the temperature of the coated wire are more than 15°F above the brittleness temperature of the PVC.

Assemble empty gabion or gabion mattress units individually, and place them on the approved surface to the lines and grades shown on the plans with the sides, ends, and diaphragms erected to ensure all creases are in the correct position, the tops of all sides are level, and all sides that are to remain exposed are straight and plumb. Fill the basket units after transporting them to their final position in the work.

Place the front row of gabion or gabion mattress units first and successively construct units toward the top of the slope or the back of the structure. Place the initial line of basket units on the prepared surface, and partially fill them to provide anchorage against deformation and displacement during subsequent filling operations. Stretch and hold empty basket units as necessary to remove kinks and provide a uniform alignment. Connect all adjoining empty gabion or gabion mattress units with lacing, wire spiral binders, or approved fasteners along the perimeter of their contact surface to obtain a monolithic structure before filling. Provide continuous stitching with alternating single and double loops at intervals of no more than 5 in. if lacing wire is used. Securely fasten all lacing wire terminals.

Provide connections meeting the joint strength requirements of Article 459.2., "Materials." These requirements apply to all connections including attachment of end panels, diaphragms, and lids.

Join twisted wire baskets through selvage-to-selvage or selvage-to-edge wire connection; do not use mesh-to-mesh or selvage-to-mesh wire connection except where baskets are offset or stacked, in which case join each mesh opening where mesh wire meets selvage or edge wire.

Carefully fill the basket units with stone, using hand placement to avoid damaging wire coating, to ensure as few voids as possible between the stones and to maintain alignment. Machine placement of stone will be allowed if approved. Correct excessive deformation and bulging of the mesh before further filling. Fill the basket units in a row in stages consisting of maximum 12 in. courses to avoid localized deformation. Do not at any time fill a cell to a depth exceeding 1 ft. more than its adjoining cell. Do not drop stones into the basket units from a height greater than 36 in.

Place 2 uniformly spaced internal connecting wires between each stone layer in all front and side gabion units, connecting the back and the front faces of the compartments for gabion units more than 2 ft. high. Loop connecting wires or preformed stiffeners around 2 twisted wire-mesh openings or a welded wire joint at each basket face, and securely twist the wire terminals to prevent loosening.

Place the outer layer of stone carefully along all exposed faces and arrange it by hand to ensure a neat and compact appearance. Overfill the last layer of stone uniformly by 1 to 2 in. for gabions and 1 in. for gabion mattresses to compensate for future settlement in rock while still allowing for the proper closing of the lid and providing an even surface with a uniform appearance. Make final adjustments for compaction and surface tolerance by hand. Stretch lids tight over the stone fill, using an approved lid-closing tool, until the lid meets the perimeter edges of the front and end panels. Do not use crowbars or other single-point leverage bars for lid closing. Close the lid tightly along all edges, ends, and internal-cell diaphragms with spiral binders or lacing wire or with other wire fasteners if approved. Ensure all projections or wire ends are turned into the baskets. Cut, fold, and wire the basket unit together to suit site conditions where a complete gabion or gabion mattress unit cannot be installed because of space limitations, as shown on the plans, or as directed. Fold the mesh back and neatly wire it to an adjacent basket face. Complete the assembling, installation, filling, lid closing, and lacing of the reshaped gabion or gabion mattress units in accordance with this Section.

4. MEASUREMENT

Gabions will be measured in place by the cubic yard of stone-filled gabions. Gabion mattresses will be measured in place by the square yard of surface area or by the cubic yard.

5. PAYMENT

The work performed and materials furnished in accordance with this Item and measured as provided under "Measurement" will be paid for at the unit price bid for "Gabions" of the basket-wire coating specified, and per square yard of "Gabion Mattresses" of the thickness and basket-wire coating specified or per cubic yard of "Gabion Mattresses" of the basket-wire coating specified.

The price bid is full compensation for wire baskets, stone fill, lacing and fasteners, filter fabric, filter material, excavation, grading and backfill, materials, tools, equipment, labor, and incidentals. Filter fabric and filter material, if used, will not be paid for directly but will be considered subsidiary to this Item.

Item 460

Corrugated Metal Pipe



1. DESCRIPTION

Furnish and install corrugated metal pipes, materials for constructing corrugated metal pipe culverts, or corrugated metal storm drain mains, laterals, stubs, and inlet leads.

2. MATERIALS

2.1. **Fabrication.** Furnish corrugated metal pipe in accordance with Table 1.

Table 1
Specifications for Corrugated Metal Pipe

Pipe Type	AASHTO Specification
Galvanized steel and aluminized steel	M 36
Aluminized Type 2	M 36
Polymer Coated	M 36 & M 245
Asphalt Coated	M 36
Aluminum	M 196

The pipe type and corresponding AASHTO designations are shown in Table 2.

Table 2
Corrugated Metal Pipe Types

Pipe Type	AASHTO Classification
Circular	Type I
Circular, smooth-lined	Type IA
Circular, spiral rib	Type IR
Arch	Type II
Arch, smooth-lined	Type IIA
Arch, spiral rib	Type IIR

Provide corrugated metal pipe of all types with annular corrugations, helical corrugations, or spiral ribs (corrugations) projecting outward. Provide pipe with helical end corrugations only when necessary to join new pipe to existing pipe with helical end corrugations.

Provide a minimum polymer coating thickness of 10 mils on each side for pre-coated galvanized steel pipe. Galvanized metal sheets and coils used for galvanized corrugated metal pipe may be sampled and tested in accordance with Tex-708-I.

Repair damaged galvanized coating in accordance with Section 445.3.5., "Repairs." Repair damaged aluminized or polymer coating in accordance with AASHTO M 36 and M 245 respectively.

2.2. **Protective Coating.** Furnish bituminous coating, when required, that meets AASHTO M 190 and that tightly adheres to the metal, does not chip off in handling, and protects the pipe from deterioration as evidenced by samples prepared from the coating material successfully meeting the Shock Test and Flow Test in accordance with Tex-522-C.

Coat the pipe uniformly inside and out to a minimum thickness of 0.05 in. measured on the crests of the corrugations. Coat the pipe with additional material applied to the full inner circumference to form a smooth inside lining with a minimum thickness of 1/8 in. above the crest of the corrugations when smooth lining is specified.

2.3.

Design. The diameter, permissible corrugations, and required gauges for full-circle pipe will be shown. The design size and permissible corrugations for pipe arch will be shown. The required gauges of the shell and the liner for smooth lined pipe will also be shown. Furnish the shape and minimum gauge for steel pipe arch in accordance with Tables 3, 4, 5, or 6 for the specified design size and corrugation. Use Table 7 or 8 for aluminum pipe arch. Refer to U.S. Standard Gauge for uncoated sheets where reference is made to gauge of metal.

Measure dimensions from the inside crests of the corrugations. A tolerance of ± 1 in. or 2% of the equivalent circular diameter, whichever is greater, is allowed for span and rise.

Table 3
Steel Pipe Arch
2-2/3 × 1/2-in. Corrugations

Design Size	Span (in.)	Rise (in.)	Min Cover (in.)	Min Gauge Required	Coated Thickness (in.)	Equivalent Diameter Full-Circle Pipe (in.)
1	17	13	12	16	0.064	15
2	21	15	12	16	0.064	18
2A	23	19	12	16	0.064	21
3	28	20	12	16	0.064	24
4	35	24	12	16	0.064	30
5	42	29	12	14	0.079	36
6	49	33	12	14	0.079	42
7	57	38	12	12	0.109	48
8	64	43	12	12	0.109	54
9	71	47	12	10	0.138	60

Table 4
Steel Pipe Arch
3 × 1-in. Corrugations

Design Size	Span (in.)	Rise (in.)	Min Cover (in.)	Min Gauge Required	Coated Thickness (in.)	Equivalent Diameter Full-Circle Pipe (in.)
7	53	41	12	14	0.079	48
8	60	46	12	14	0.079	54
9	66	51	12	14	0.079	60
10	73	55	12	14	0.079	66
11	81	59	12	14	0.079	72
12	87	63	12	14	0.079	78
13	95	67	12	12	0.109	84
14	103	71	18	12	0.109	90
15	112	75	18	12	0.109	96
16	117	79	18	12	0.109	102
17	128	83	24	10	0.138	108
18	137	87	24	10	0.138	114
19	142	91	24	10	0.138	120

Table 5
Steel Pipe Arch
5 × 1-in. Corrugations

Design Size	Span (in.)	Rise (in.)	Min Cover (in.)	Min Gauge Required	Coated Thickness (in.)	Equivalent Diameter Full-Circle Pipe (in.)
11	81	59	12	12	0.109	72
12	87	63	12	12	0.109	78
13	95	67	12	12	0.109	84
14	103	71	18	12	0.109	90
15	112	75	18	12	0.109	96
16	117	79	18	12	0.109	102
17	128	83	24	10	0.138	108
18	137	87	24	10	0.138	114
19	142	91	24	10	0.138	120

Table 6
Steel Pipe Arch, Spiral Rib
7-1/2 × 3/4 × 3/4-in. Corrugations

Design Size	Span (in.)	Rise (in.)	Min Cover (in.)	Min Gauge Required	Coated Thickness (in.)	Equivalent Diameter Full-Circle Pipe (in.)
2	20	16	12	16	0.064	18
2A	23	19	12	16	0.064	21
3	27	21	12	16	0.064	24
4	33	26	12	16	0.064	30
5	40	31	12	14	0.064	36
6	46	36	12	12	0.064	42
7	53	41	12	12	0.079	48
8	60	46	12	12	0.079	54
9	66	51	15	12	0.079	60

Table 7
Aluminum Pipe Arch
2-2/3 × 1/2-in. Corrugations

Design Size	Span (in.)	Rise (in.)	Min Cover (in.)	Min Gauge Required	Coated Thickness (in.)	Equivalent Diameter Full-Circle Pipe (in.)
1	17	13	12	16	0.060	15
2	21	15	12	16	0.060	18
2A	23	19	12	16	0.060	21
3	28	20	12	14	0.075	24
4	35	24	12	14	0.075	30
5	42	29	18	12	0.105	36
6	49	33	18	12	0.105	42
7	57	38	18	10	0.135	48
8	64	43	18	10	0.135	54
9	71	47	18	8	0.164	60

Table 8
Aluminum Pipe Arch, Spiral Rib
7-1/2 × 3/4 × 3/4-in. Corrugations

Design Size	Span (in.)	Rise (in.)	Min Cover (in.)	Min Gauge Required	Coated Thickness (in.)	Equivalent Diameter Full-Circle Pipe (in.)
2	20	16	12	16	0.064	18
2A	23	19	12	16	0.064	21
3	27	21	15	16	0.064	24
4	33	26	18	16	0.064	30
5	40	31	18	14	0.075	36
6	46	36	18	12	0.105	42
7	53	41	21	12	0.105	48
8	60	46	18	10	0.135	54
9	66	51	21	10	0.135	60

- 2.4. **Coupling Bands.** Furnish coupling bands and other hardware for galvanized or aluminized steel pipe in accordance with AASHTO M 36 for steel pipe and AASHTO M 196 for aluminum pipe. Use coupling bands that are no more than 3 nominal sheet thicknesses lighter than the thickness of the pipe to be connected or no lighter than 0.052 in. for steel or 0.048 in. for aluminum. Provide coupling bands made of the same base metal and coating as the pipe.

3. CONSTRUCTION

- 3.1. **Designation of Type.** The types of pipes will be indicated on the plans by the following descriptions:
- Pipe type: Corrugated metal pipe (CMP), corrugated metal pipe arch (CMP ARCH), spiral rib corrugated metal pipe (SRCMP), or spiral rib corrugated metal pipe arch (SRCMP ARCH);
 - Type of material: Galvanized steel, aluminum-coated (Type 2), or aluminum;
 - Pipe coating: Bituminous coated or polymer coated;
 - Special requirements: Paved invert or smooth lining; and
 - Pipe size: Diameter or design number.

Furnish any of the material types specified above when pipe is designated as "Corrugated Metal Pipe" without a type of material or pipe coating designation.

- 3.2. **Excavation, Shaping, Bedding, and Backfill.** Excavate, shape, bed, and backfill in accordance with Item 400, "Excavation and Backfill for Structures," except where jacking, boring, or tunneling methods are shown on the plans or permitted. Jack, bore, or tunnel in accordance with Item 476, "Jacking, Boring, or Tunneling Pipe or Box."

Provide uniform backfill material and uniformly compacted density throughout the length of the structure so equal pressure is provided. Allow no heavy earth-moving equipment over the structure until a minimum of 4 ft. of compacted fill (permanent or temporary) has been placed over the top of the structure unless otherwise shown on the plans or permitted in writing. Inspect the inside periphery of the structure for local or unequal deformation caused by improper construction methods before adding each new layer of loose backfill material. Continue inspections until a minimum of 24 in. of cover is obtained. Evidence of such deformation will be reason for corrective measures as directed. Remove and replace pipe damaged by the Contractor at no additional cost to the Department.

- 3.3. **Laying Pipe.** Lay pipes on the bedding from the outlet end and join the separate sections firmly together with outside laps of annular joints pointing upstream and longitudinal laps on the sides unless otherwise authorized. Coat any metal in joints not protected by galvanizing or aluminizing with a suitable asphalt paint. Lower sections of pipe into the trench without damaging the pipe or disturbing the bedding and the sides of the trench. Remove and re-lay, without extra compensation, pipe that is not in alignment or shows excessive settlement after laying.

Lay multiple installations of corrugated metal pipe and pipe arches with the centerlines of individual barrels parallel. Maintain the clear distances between outer surfaces of adjacent pipes given in Table 9 unless otherwise indicated on the plans.

Table 9
Required Pipe Clear Distances

Diameter Full-Circle Pipe (in.)	Pipe Arch Design Size	Clear Distance Between Pipes (Full-Circle Pipe and Pipe Arch)
18	2	1 ft. 2 in.
21	2A	1 ft. 3 in.
24	3	1 ft. 5 in.
30	4	1 ft. 8 in.
36	5	1 ft. 11 in.
42	6	2 ft. 2 in.
48	7	2 ft. 5 in.
54	8	2 ft. 10 in.
60 to 84	9	3 ft. 2 in.
90 to 120	10 and over	3 ft. 5 in.

- 3.4. **Jointing.** Provide field joints that maintain pipe alignment during construction and prevent infiltration of side material during the life of the installation. Provide one of the following jointing systems unless otherwise shown on the plans.

- 3.4.1. **Coupling Bands.** Use coupling bands with annular corrugations only with pipe with annular corrugations or with helical pipe or spiral rib pipe in which the ends have been rerolled to form annular corrugations. Provide bands with corrugations that have the same dimensions as the corrugations in the pipe end or are designed to engage the first or second corrugation from the end of each pipe. The band may also include a U-shaped channel to accommodate upturned flanges on the pipe.

Field-join pipe with helically corrugated bands or bands with projections (dimples) when helical end corrugations are allowed.

Coupling bands with projections may be used with pipe that has annular or helical end corrugations or spiral ribs. Provide bands formed with the projections in annular rows with 1 projection for each corrugation of helical pipe or spiral rib pipe. Provide 2 annular rows for bands 10-1/2 in. or 12 in. wide and 4 annular rows of projections for bands 16-1/2 in. or 22 in. wide.

Use a coupling band width that conforms to Table 10. Connect the bands using suitable galvanized devices in accordance with AASHTO M 36. Lap coupling bands equally on each of the pipes to form a tightly closed joint after installation. Provide at least the minimum coupling band width recommended by the manufacturer for corrugations not shown in Table 10.

Table 10
Coupling Band Width Requirements

Nominal Corrugation Size ¹ (in.)	Nominal Pipe Inside Diameter ² (in.)	Minimum Coupling Band Width (in.)		
		Annular Corrugated Bands	Helically Corrugated Bands	Bands with Projections
2-2/3 by 1/2	12 to 36	7	12	10-1/2
	42 to 72	10-1/2	12	10-1/2
	78 to 84 ³	10-1/2	12	16-1/4
3 by 1	36 to 72	12	14	10-1/2
	78 to 120	12	14	16-1/4
5 by 1	36 to 72	20	22	12
	78 to 120	20	22	22
7-1/2 by 3/4 by 3/4	18 to 60	10-1/2	12	10-1/2
	66 to 102	10-1/2	12	16-1/4

1. For helically corrugated pipe or spiral rib pipe with rerolled ends, the nominal size refers to the dimensions of the end corrugations in the pipe.
2. Equivalent circular diameter for Type II pipe.
3. Diameter through 120 in. for annular corrugated bands used on rerolled ends of helically corrugated pipe or spiral rib pipe.

The minimum diameter of bolts for coupling bands is 3/8 in. for pipe diameters 18 in. and less and 1/2 in. for pipe diameters 21 in. and greater. Provide at least 2 bolts for bands 12 in. wide or less. Provide at least 3 bolts for bands wider than 12 in.

Provide galvanized hardware in accordance with Item 445, "Galvanizing."

- 3.4.2. **Bell and Spigot.** Attach the bell to one end of the corrugated metal pipe at the manufacturing plant before shipment. Provide a bell with a minimum 6-in. stab depth. Install the gasket on the spigot end and apply lubricant in accordance with the manufacturer's recommendations. Provide gaskets that meet ASTM F477 with Type A Shore durometer hardness of 45 ±5. Do not use thermoplastic elastomer as the basic polymer. Push the spigot end of the pipe into the bell end of the previously laid pipe during laying of the pipe.
- 3.4.3. **Pipe Connections and Stub Ends.** Make connections of pipe to existing pipe or appurtenances as shown on the plans or as directed. Mortar or concrete the bottom of the existing structure, if necessary, to eliminate any drainage pockets created by the new connection.

Insulate portions of aluminum pipe that are to be in contact with metal other than aluminum by a coating of bituminous material meeting the requirements of Section 460.2.2., "Protective Coating." Extend the coating a minimum of 1 ft. beyond the area of contact.

Restore any damage that results from making the connection when connecting pipe into existing structures that will remain in service. Seal stub ends for connections to future work not shown on the plans by installing watertight plugs into the free end of the pipe.

4. MEASUREMENT

This Item will be measured by the foot. Pipe will be measured between the ends of the barrel along the flow line, not including safety end treatments. Safety end treatments will be measured in accordance with Item 467, "Safety End Treatment." Pipe that is required to be jacked, bored, or tunneled will be measured in accordance with Item 476, "Jacking, Boring, or Tunneling Pipe or Box." Where spurs, branches, or connections to existing pipe lines are involved, measurement of the spur or new connecting pipe will be made from the intersection of the flow line with the outside surface of the pipe into which it connects. Where inlets, headwalls, catch basins, manholes, junction chambers, or other structures are included in lines of pipe, the length of pipe tying into the structure wall will be included for measurement but no other portion of the structure length or width will be included.

For multiple pipes, the measured length will be the sum of the lengths of the barrels.

This is a plans quantity measurement Item. The quantity to be paid is the quantity shown in the proposal, unless modified by Article 9.2., "Plans Quantity Measurement." Additional measurements or calculations will be made if adjustments of quantities are required.

5. PAYMENT

The work performed and materials furnished in accordance with this Item and measured as provided under "Measurement" will be paid for at the unit price bid for "Corrugated Metal Pipe," "Corrugated Metal Pipe Arch," "Spiral Rib Corrugated Metal Pipe," or "Spiral Rib Corrugated Metal Pipe Arch" of the type, size, and coating specified. This price is full compensation for furnishing, hauling, placing, and joining of pipes; jointing materials; all connections to new or existing structures; breaking back, removing, and disposing of portions of the existing structure; replacing portions of the existing structure; cutting pipe ends on skew or slope; and equipment, labor, tools, and incidentals.

Protection methods for excavations greater than 5 ft. deep will be measured and paid for as required under Item 402, "Trench Excavation Protection," or Item 403, "Temporary Special Shoring." Excavation, shaping, bedding, and backfill will be paid for in accordance with Item 400, "Excavation and Backfill for Structures." When jacking, boring, or tunneling is used at the Contractor's option, payment will be made under this Item. When jacking, boring, or tunneling is required, payment will be made under Item 476, "Jacking, Boring, or Tunneling Pipe or Box."

Item 461

Structural Plate Structures



1. DESCRIPTION

Furnish and install structural plate pipes, pipe arches, arches, underpasses, box culverts, and special shapes.

2. MATERIALS

2.1. **General.** Furnish materials in accordance with the following.

- Item 420, "Concrete Substructures,"
- Item 421, "Hydraulic Cement Concrete,"
- Item 440, "Reinforcement for Concrete,"
- Item 442, "Metal for Structures,"
- Item 445, "Galvanizing," and
- Item 447, "Structural Bolting."

Provide galvanized steel plates conforming to AASHTO M 167. Provide aluminum plates conforming to AASHTO M 219.

Use Class C concrete for footings unless otherwise shown on the plans.

Fabrication. Use structural units of corrugated galvanized metal for steel plates. Furnish single plates in standard sizes to permit structure length increments of 2 ft. Provide plates with an approximate 2-in. lip beyond each end crest. Design and construct footings for arches to accommodate this additional length. Fabricate galvanized steel inverts, toe walls, footings, and closure plates when required in accordance with the requirements for the galvanized steel structural plate structure.

Use structural units of corrugated aluminum alloy for aluminum plates. Furnish cut plates on structure ends to permit structure length increments of 1 ft. for aluminum alloy structures. Provide plates with an approximate 2-in. lip beyond each end crest. Design and construct footings for arches to accommodate this additional length. Fabricate aluminum alloy inverts, toe walls, footings, and closure plates in accordance with the requirements for the aluminum structural plate structure when required.

Form plates to provide bolted lap joints. Punch bolt holes so all plates with like dimensions, curvature, and number of bolts per foot of seam will be interchangeable. Curve each plate to the proper radius to provide cross-sectional dimensions of the finished structure as shown on the plans. Stagger joints so no more than 3 plates are joined at any one point.

Provide bolt holes along the edges of the plates, unless otherwise specified, that will form longitudinal seams in the finished structure as follows:

- Stagger holes in rows 2 in. apart, with one row in the valley and one on the crest of the corrugations and at least 4 bolts per foot for galvanized steel structures.
- Provide holes in rows 1-3/4 in. apart with 2 bolts in each valley and on each crest and at least 16 bolts per 3 feet for aluminum alloy structures.

Provide bolt holes at a maximum spacing of 12 in. along the edges of the plates that will form circumferential seams in the finished structure. Ensure a minimum distance from center of hole to edge of plate of at least 1-3/4 times the diameter of the bolt. Provide bolt holes in the longitudinal seams with a hole diameter that

does not exceed the diameter of the bolt by more than 1/8 in. Finish burned edges so they are galvanized and free from oxide and burrs and present a satisfactory appearance. Place legible identification marks on each plate to designate its proper position in the finished structure.

Furnish an itemized statement of the number and size of plates in each shipment and furnish erection drawings showing the position of the plates in the structure. Furnish copies of mill test reports for the base metal. Provide samples of the plates in accordance with Tex-708-I, when directed.

Provide metal headwalls that comply with the details shown on the plans.

- 2.2. **Design.** The gauge or minimum thickness and permissible corrugations of metal plates to be furnished for each structure will be shown on the plans.

3. CONSTRUCTION

- 3.1. **Designation of Type.** The type of structure will be indicated on the plans by the following descriptions:

- Structure type: structural plate pipe, structural plate pipe arch, structural plate arch, structural plate underpass, or structural plate box culvert.
- Type of material: galvanized steel or aluminum.
- Structure size: diameter or horizontal and vertical dimensions.
- When the type of material is not specified: either galvanized steel or aluminum.

- 3.2. **Foundations.** Construct substructure for structural plate arches as shown on the plans. Form and finish footings to established true lines and grades. Set anchors or box culvert slots to true line and grade when placing concrete for each substructure unit. Place substructure units in accordance with Item 420, "Concrete Substructures," and Item 440, "Reinforcement for Concrete."

Place footings entirely on hard materials such as rock or shale or on firm soil or compacted soil cushion. Undercut and replace rock with a minimum 12 in. thick compacted soil cushion when only a portion of the founding area is rock. Remove the soil when a thin layer is partially covering rock within the bearing area and place the footings directly on rock in accordance with details shown on the plans.

- 3.3. **Erection.** Coat any steel in joints not protected by galvanizing with suitable asphalt paint. Handle pipes and plates carefully to avoid damage to any protective coating.

Provide hot-dip galvanized anchor bolts with a minimum 3/4-in. diameter and 6-in. length spaced at maximum 19-in. centers for anchoring plates to headwalls or other concrete end treatment. Place plates for arch structures after the substructure has cured a minimum of 3 days.

Insert all bolts not already in place when all plates are in position, and tighten all nuts progressively and uniformly, beginning at one end of the structure. Tighten all nuts a second time to a torque between 150 and 300 ft. lb. for steel bolts and between 100 and 150 ft. lb. for aluminum bolts. Check at least 20% of the bolts with a torque wrench when using an impact wrench. Replace all service bolts used in drawing the plates together with standard bolts.

The tolerance for span and rise during erection is 2% of design measurements or 5 in., whichever is less.

- 3.4. **Workmanship.** Repair minor damage to galvanized coating in accordance with Section 445.3.5., "Repairs." All other structural plates on which the galvanized coating has been damaged or that show defective workmanship will be rejected. This requirement applies not only to the individual plates but also to the shipment as a whole. The presence of any of the following defects will be cause for rejection:

- uneven laps;
- elliptical shape (unless specified);
- variation from a straight line;

- ragged edges;
- loose bolts;
- uneven bolt lines or spacing;
- illegible brand;
- bruised, scaled, or broken galvanized coating; or
- dents or bends in the metal.

3.5. **Excavation and Backfill.** Excavate and backfill or construct the embankment around and over the structural plate structure in accordance with Item 400, "Excavation and Backfill for Structures," except as modified in this Section. Furnish acceptable devices for monitoring the horizontal and vertical shape of the structure. The tolerance for span and rise during backfilling operations is 2% of design measurements or 5 in., whichever is less.

For arches (except pipe arches), if the headwalls are built after backfilling the arch, place the first material midway between the ends of the arch, forming as narrow a ramp as possible until the top of the arch is reached. Construct the ramp evenly from both sides, and thoroughly compact the backfill as it is placed. Deposit the remainder of the backfill from the top of the arch both ways from the center to the ends and as evenly as possible on both sides of the arch after constructing the 2 ramps to the top of the arch. If the headwalls are built before backfilling the arch, place the fill material first adjacent to one headwall until the top of the arch has been reached and then from the top of the arch toward the other headwall. Deposit the material evenly on both sides of the arch.

Perform the same backfill phases for all structures more or less simultaneously. Do not drop backfill from such a height or concentrate it in such an amount before distribution over the top arch that it will damage the flexible structure. Compact this backfill with hand-operated tamps or other acceptable equipment.

Use only hand-operated, mechanical tamping equipment within vertical planes 2 ft. beyond the horizontal limits of the structure until a minimum of 2 ft. of cover has been compacted over the structure. Ensure all large construction equipment is kept a minimum of 3 ft. from the center of the span to prevent local deformations of the plates due to concentrated loads. Do not use heavy earth-moving equipment over the structure until a minimum of 4 ft. of permanent or temporary compacted fill has been placed over the structure unless otherwise shown on the plans or permitted in writing. Check with the structure manufacturer before crossing the structure with any construction equipment with a 75,000 lb. or greater single-axle load. Additional cover beyond 4 ft. may be required to accommodate these vehicles. Remove and replace damaged plates or structures at no expense to the Department.

Inspect the inside periphery of the structure for local or unequal deformation caused by improper construction methods before adding each new layer of loose backfill material. Continue inspections until a minimum of 24 in. of cover is obtained. Evidence of such deformation will be reason for corrective measures as directed.

4. MEASUREMENT

Structural plate pipes, pipe arches, arches, underpasses, and box culverts will be measured by the foot. Measurement will be made between the ends of the barrel along the flow line, not including safety end treatments. Safety end treatments will be measured in accordance with Item 467, "Safety End Treatment."

For multiple structures, the measured length will be the sum of the lengths of the barrels.

This is a plans quantity measurement item. The quantity to be paid is the quantity shown in the proposal unless modified by Article 9.2., "Plans Quantity Measurement." Additional measurements or calculations will be made if adjustments of quantities are required.

5. PAYMENT

The work performed and materials furnished in accordance with this Item and measured as provided under "Measurement" will be paid for at the price bid for "Structural Plate Pipes," "Structural Plate Pipe Arches," "Structural Plate Underpasses," and "Structural Plate Box Culverts" of the size, gauge or minimum thickness, and material specified. This price is full compensation for furnishing, transporting, and erecting the structural plate structures; bolts, nuts, washers, anchor bolts, and anchor channels or angles; aluminum alloy inverts, toe walls, footings, closure plates, and stiffeners; and equipment, labor, tools, and incidentals.

Inverts, toe walls, footings, closure plates, elbows, skewed sections, and stiffeners will not be paid for directly but are subsidiary to this Item.

Protection methods for excavations greater than 5 ft. in depth will be measured and paid for as required under Item 402, "Trench Excavation Protection," or Item 403, "Temporary Special Shoring." Excavation, shaping, bedding, and backfill will be paid for in accordance with Item 400, "Excavation and Backfill for Structures."

Item 462

Concrete Box Culverts and Drains



1. DESCRIPTION

Furnish, construct, and install concrete box culverts and drains.

2. MATERIALS

2.1. **General.** Furnish materials in accordance with the following.

- Item 420, "Concrete Substructures,"
- Item 421, "Hydraulic Cement Concrete,"
- Item 440, "Reinforcement for Concrete," and
- Item 464, "Reinforced Concrete Pipe."

Provide cast-in-place or precast, formed or machine-made, box culverts, and drains. Use Class S concrete for top slabs of cast-in-place concrete culverts for culverts with overlay, a 1- to 2-course surface treatment or a top slab that is the final riding surface unless otherwise shown on the plans. Use Class C concrete for the rest of the culvert and for all other cast-in-place boxes. Culverts with fill do not require Class S concrete.

Furnish material for machine-made precast boxes in accordance with DMS-7310, "Reinforced Concrete Pipe and Machine-Made Precast Concrete Box Culvert Fabrication and Plant Qualification."

2.2. **Fabrication.**

2.2.1. **Cast-in-Place.** Meet Item 420, "Concrete Substructures" and Item 422, "Concrete Superstructures."

2.2.2. **Formed Precast.** Meet Item 424, "Precast Concrete Structural Members (Fabrication)."

2.2.3. **Machine-Made Precast.** Machine-made precast box culvert fabrication plants must be approved in accordance with DMS-7310, "Reinforced Concrete Pipe and Machine-Made Precast Concrete Box Culvert Fabrication and Plant Qualification." The Department's MPL shows approved machine-made precast box culvert plants. Fabricate machine-made precast boxes in accordance with DMS-7310, "Reinforced Concrete Pipe and Machine-Made Precast Concrete Box Culvert Fabrication and Plant Qualification."

2.3. **Testing.**

2.3.1. **Cast-in-Place.** Provide test specimens that meet Item 421, "Hydraulic Cement Concrete."

2.3.2. **Formed Precast.** Make, cure, and test compressive test specimens in accordance with Tex-704-I.

2.3.3. **Machine-Made Precast.** Make, cure, and test compressive test specimens in accordance with DMS-7310, "Reinforced Concrete Pipe and Machine-Made Precast Concrete Box Culvert Fabrication and Plant Qualification."

2.3.4. **Testing Equipment.** The producer must furnish all equipment required for testing concrete for boxes produced in a precasting plant.

2.4. **Lifting Holes.** Provide no more than 4 lifting holes in each section for precast boxes. Lifting holes may be cast, cut into fresh concrete after form removal, or drilled. Provide lifting holes large enough for adequate

lifting devices based on the size and weight of the box section. Use lifting holes no larger than 3 in. in diameter. Cut no more than 5 in. in any direction of reinforcement per layer for lifting holes.

2.5. **Marking.** Mark precast boxes with the following:

- name or trademark of fabricator and plant location;
- ASTM designation;
- date of manufacture;
- box size;
- minimum and maximum fill heights;
- designated fabricator's approval stamp;
- boxes to be used for jacking and boring (when applicable);
- designation "SR" for boxes meeting sulfate-resistant concrete plan requirements (when applicable); and
- match-marks for proper installation, when required under Section 462.2.6., "Tolerances."

Mark 1 end of each box section, for boxes without lifting holes, on the inside and outside walls to indicate the top or bottom as it will be installed.

Indent markings into the box section or paint them on each box with waterproof paint.

2.6. **Tolerances.** Ensure precast sections meet the permissible variations listed in ASTM C1577 and that the sides of a section at each end do not vary from being perpendicular to the top and bottom by more than 1/2 in. when measured diagonally between opposite interior corners.

Ensure wall and slab thicknesses are not less than shown on the plans except for occasional deficiencies not greater than 3/16 in. or 5%, whichever is greater. If proper jointing is not affected, thicknesses in excess of plan requirements are acceptable.

Deviations from the above tolerances will be acceptable if the sections can be fitted at the plant or jobsite and the joint opening at any point does not exceed 1 in. Use match-marks for proper installation on sections that have been accepted in this manner.

2.6.1. **Boxes for Jacking Operations.** Use boxes for jacking operations as defined in Item 476, "Jacking, Boring, or Tunneling Pipe or Box," meeting the following additional requirements:

- The box ends must be square such that no point deviates more than 3/8 in. from a plane placed on the end of the box that is perpendicular to the box sides, and
- The slab and wall thicknesses must not be less than specified on the plans and must not exceed the specified thickness by more than 1/2 in.

2.7. **Defects and Repair.** Fine cracks on the surface of the member that do not extend to the plane of the nearest reinforcement are acceptable unless the cracks are numerous and extensive. Repair cracks that extend into the plane of the reinforcing steel in an approved manner. Excessive damage, honeycomb, or cracking will be subject to structural review. The Engineer may accept boxes with repairs that are sound, properly finished, and cured in conformance with pertinent specifications. Discontinue further production of precast sections when fine cracks on the surface indicate poor curing practices until corrections are made and proper curing is provided.

Repair machine-made precast boxes in accordance with DMS-7310, "Reinforced Concrete Pipe and Machine-Made Precast Concrete Box Culvert Fabrication and Plant Qualification."

2.8. **Storage and Shipment.** Store precast sections on a level surface. Do not place any load on the sections until design strength is reached and curing is complete. Shipment of sections is permissible when the design strength and curing requirements have been met.

Store and ship machine-made precast boxes in accordance with DMS-7310, "Reinforced Concrete Pipe and Machine-Made Precast Concrete Box Culvert Fabrication and Plant Qualification."

3. CONSTRUCTION

- 3.1. **Excavation, Shaping, Bedding, and Backfill.** Excavate, shape, bed, and backfill in accordance with Item 400, "Excavation and Backfill for Structures," except where jacking, boring, or tunneling methods are shown on the plans or permitted. Jack, bore, or tunnel in accordance with Item 476, "Jacking, Boring, or Tunneling Pipe or Box." Immediate backfilling is permitted for all box structures where joints consist of materials other than mortar. Take precautions in placing and compacting the backfill to avoid any movement of the boxes or damage to the joints. Remove and replace boxes damaged by the Contractor at no expense to the Department.
- 3.2. **Placement of Boxes.** Place the box sections in conformance with the plans or as directed when precast boxes are used to form multiple barrel structures. Place material to be used between barrels as shown on the plans or as directed. Start the laying of boxes on the bedding at the outlet end and proceed toward the inlet end with the abutting sections properly matched unless otherwise authorized. Fit, match, and lay the boxes to form a smooth, uniform conduit true to the established lines and grades. Lower the box sections into the trench, for trench installations, without damaging the box or disturbing the bedding and the sides of the trench. Carefully clean the ends of the box before it is placed. Prevent the earth or bedding material from entering the box as it is laid. Remove and re-lay, without extra compensation, boxes that are not in alignment or show excessive settlement after laying. Form and place cast-in-place boxes in accordance with Item 420, "Concrete Substructures."
- 3.3. **Jointing.** Use any of the jointing materials in accordance with the joint requirements specified in Item 464, "Reinforced Concrete Pipe," unless otherwise shown on the plans. Box joints for rubber gasketed material may be substituted for tongue and groove joints, provided they meet the requirements of ASTM C1677 for design of the joints and permissible variations in dimensions.
- 3.4. **Connections and Stub Ends.** Make connections of boxes to existing boxes, pipes, drains, or drain appurtenances as shown on the plans. Mortar or concrete the bottom of existing structures if necessary to eliminate any drainage pockets created by the connections. Connect boxes to any required headwalls, wingwalls, safety end treatments or riprap, or other structures as shown on the plans or as directed. Repair any damage to the existing structure resulting from making the connections. Finish stub ends for connections to future work not shown on the plans by installing watertight plugs into the free end of the box.
- Fill lifting holes with mortar or concrete and cure for precast boxes. Precast concrete or mortar plugs may be used.
- 3.5. **Extending.** Break back and extend existing culverts in accordance with Section 420.4.8 "Extending Existing Substructures," and Section 422.4.5 "Extending Existing Slabs," as applicable.

4. MEASUREMENT

This Item will be measured by the foot. Measurement will be made between the ends of the culvert or drain along the flow line, not including safety end treatments. Safety end treatments will be measured in accordance with Item 467, "Safety End Treatment." Measurement of spurs, branches, or new connection box section will be made from the intersection of the flow line with the outside surface of the structure into which it connects. Where inlets, headwalls, wingwalls, catch basins, manholes, junction chambers, or other structures are included in lines of culverts or drains, the length of box section tying into the structure wall will be included for measurement, but no other portion of the structure length or width will be included.

The measured length of multiple barrel structures will be the sum of the lengths of the barrels.

This is a plans quantity measurement Item. The quantity to be paid is the quantity shown in the proposal unless modified by Article 9.2., "Plans Quantity Measurement." Additional measurements or calculations will be made if adjustments of quantities are required.

5. PAYMENT

The work performed and materials furnished in accordance with this Item and measured as provided under "Measurement" will be paid for at the unit price bid for "Concrete Box Culvert" of the size specified. This price is full compensation for constructing, furnishing, and transporting sections; preparation and shaping of the bed; backfill material between box sections; jointing of sections; jointing material; cutting of sections on skew or slope; connections to new or existing structures; breaking back, removing and disposing of portions of the existing structure and replacing portions of the existing structure as required to make connections; concrete and reinforcing steel; and equipment, labor, materials, tools, and incidentals.

Protection methods for excavations greater than 5 ft. deep will be measured and paid for as required under Item 402, "Trench Excavation Protection," or Item 403, "Temporary Special Shoring." Excavation, shaping, bedding, and backfill will be paid for in accordance with Item 400, "Excavation and Backfill for Structures." When jacking, boring, or tunneling is used at the Contractor's option, payment will be made under this Item. When jacking, boring, or tunneling is required, payment will be made under Item 476, "Jacking, Boring, or Tunneling Pipe or Box."

Item 464

Reinforced Concrete Pipe



1. DESCRIPTION

Furnish and install reinforced concrete pipe, materials for precast concrete pipe culverts, or precast concrete storm drain mains, laterals, stubs, and inlet leads.

2. MATERIALS

- 2.1. **Fabrication.** Fabrication plants must be approved by the Construction Division in accordance with DMS-7310, "Reinforced Concrete Pipe and Machine-Made Precast Concrete Box Culvert Fabrication and Plant Qualification," before furnishing precast reinforced concrete pipe for Department projects. The Department's MPL has a list of approved reinforced concrete pipe plants.

Furnish material and fabricate reinforced concrete pipe in accordance with DMS-7310, "Reinforced Concrete Pipe and Machine-Made Precast Concrete Box Culvert Fabrication and Plant Qualification."

2.2. Design.

- 2.2.1. **General.** The class and D-load equivalents are shown in Table 1. Furnish arch pipe in accordance with ASTM C506 and the dimensions shown in Table 2. Furnish horizontal elliptical pipe in accordance with ASTM C507 and the dimensions shown in Table 3. For arch pipe and horizontal elliptical pipe the minimum height of cover required is 1 ft.

Table 1
Circular Pipe
ASTM C76 & ASTM C655

Class	D-Load
I	800
II	1,000
III	1,350
IV	2,000
V	3,000

Table 2
Arch Pipe

Design Size	Equivalent Diameter (in.)	Rise (in.)	Span (in.)
1	18	13-1/2	22
2	21	15-1/2	26
3	24	18	28-1/2
4	30	22-1/2	36-1/4
5	36	26-5/8	43-3/4
6	42	31-5/16	51-1/8
7	48	36	58-1/2
8	54	40	65
9	60	45	73
10	72	54	88

Table 3
Horizontal Elliptical Pipe

Design Size	Equivalent Diameter (in.)	Rise (in.)	Span (in.)
1	18	14	23
2	24	19	30
3	27	22	34
4	30	24	38
5	33	27	42
6	36	29	45
7	39	32	49
8	42	34	53
9	48	38	60
10	54	43	68

- 2.2.2. **Jacking, Boring, or Tunneling.** Design pipe for jacking, boring, or tunneling considering the specific installation conditions such as the soil conditions, installation methods, anticipated deflection angles, and jacking stresses. Provide design notes and drawings signed and sealed by a Texas licensed professional engineer when requested.
- 2.3. **Marking.** Furnish each section of reinforced concrete pipe marked with the following information specified in DMS-7310, "Reinforced Concrete Pipe and Machine-Made Precast Concrete Box Culvert Fabrication and Plant Qualification."
- class or D-load of pipe,
 - ASTM designation,
 - date of manufacture,
 - pipe size,
 - name or trademark of fabricator and plant location,
 - designated fabricator's approval stamp,
 - pipe to be used for jacking and boring (when applicable), and
 - designation "SR" for pipe meeting sulfate-resistant concrete plan requirements (when applicable).
- Clearly mark 1 end of each section during the process of manufacture or immediately thereafter for pipe with elliptical reinforcement. Mark the pipe on the inside and outside of opposite walls to show the location of the top or bottom of the pipe as it should be installed unless the external shape of the pipe is such that the correct position of the top and bottom is obvious. Mark the pipe section by indenting or painting with waterproof paint.
- 2.4. **Inspection.** Provide access for inspection of the finished pipe at the project site before and during installation.
- 2.5. **Causes for Rejection.** Individual section of pipe may be rejected for any of the conditions stated in the Annex of DMS-7310, "Reinforced Concrete Pipe and Machine-Made Precast Concrete Box Culvert Fabrication and Plant Qualification."
- 2.6. **Repairs.** Make repairs if necessary as stated in the Annex of DMS-7310, "Reinforced Concrete Pipe and Machine-Made Precast Concrete Box Culvert Fabrication and Plant Qualification."
- 2.7. **Jointing Materials.** Use any of the following materials for the making of joints unless otherwise shown on the plans. Furnish a manufacturer's certificate of compliance for all jointing materials except mortar.
- 2.7.1. **Mortar.** Provide mortar for joints that meets the requirements of Section 464.3.3., "Jointing."
- 2.7.2. **Cold-Applied, Plastic Asphalt Sewer Joint Compound.** Provide a material that consists of natural or processed asphalt base, suitable volatile solvents, and inert filler. Ensure the consistency is such that the ends of the pipe can be coated with a layer of the compound up to 1/2 in. thick by means of a trowel. Provide

a joint compound that cures to a firm, stiff plastic condition after application. Provide a material of a uniform mixture. Stir any small separation found in the container into a uniform mix before using.

Provide a material that meets the requirements of Table 4 when tested in accordance with Tex-526-C.

Table 4
Cold-Applied, Plastic Asphalt Sewer Joint Compound Material Requirements

Composition	Analysis
Asphalt base, 100%–% volatiles–% ash, % by weight	28–45
Volatiles, 212°F evaporation, 24 hr., % by weight	10–26
Mineral matter, determined as ash, % by weight	30–55
Consistency, cone penetration, 150 q, 5 sec., 77°F	150–275

- 2.7.3. **Rubber Gaskets.** Provide gaskets that conform to ASTM C1619 Class A or C. Meet the requirements of ASTM C443 for design of the pipe joints and permissible variations in dimensions.
- 2.7.4. **Pre-Formed Flexible Joint Sealants.** Pre-formed flexible joint sealants may be used for sealing joints of tongue-and-groove concrete pipe. Provide flexible joint sealants that meet the requirements of ASTM C990. Use flexible joint sealants that do not depend on oxidizing, evaporating, or chemical action for its adhesive or cohesive strength. Supply in extruded rope form of suitable cross-section. Provide a size of the pre-formed flexible joint sealant in accordance with the manufacturer's recommendations and large enough to properly seal the joint. Protect flexible joint sealants with a suitable wrapper able to maintain the integrity of the jointing material when the wrapper is removed.

3. CONSTRUCTION

- 3.1. **Excavation, Shaping, Bedding, and Backfill.** Excavate, shape, bed, and backfill in accordance with Item 400, "Excavation and Backfill for Structures," except where jacking, boring, or tunneling methods are permitted. Jack, bore, or tunnel the pipe in accordance with Item 476, "Jacking, Boring, or Tunneling Pipe or Box." Immediate backfilling is permitted if joints consist of materials other than mortar. Take special precautions in placing and compacting the backfill to avoid any movement of the pipe or damage to the joints. Do not use heavy earth-moving equipment to haul over the structure until a minimum of 4 ft. of permanent or temporary compacted fill has been placed over the structure unless otherwise shown on the plans or permitted in writing. Remove and replace pipe damaged by the Contractor at no expense to the Department.
- 3.2. **Laying Pipe.** Start the laying of pipe on the bedding at the outlet end with the spigot or tongue end pointing downstream, and proceed toward the inlet end with the abutting sections properly matched, true to the established lines and grades unless otherwise authorized. Fit, match, and lay the pipe to form a smooth, uniform conduit. Cut cross trenches in the foundation to allow the barrel of the pipe to rest firmly upon the bedding where bell-and-spigot pipe is used. Cut cross trenches no more than 2 in. larger than the bell ends of the pipe. Lower sections of pipe into the trench without damaging the pipe or disturbing the bedding and the sides of the trench. Carefully clean the ends of the pipe before the pipe is placed. Prevent the earth or bedding material from entering the pipe as it is laid. Lay the pipe in the trench, when elliptical pipe with circular reinforcing or circular pipe with elliptical reinforcing is used, so the markings for the top or bottom are not more than 5° from the vertical plane through the longitudinal axis of the pipe. Remove and re-lay, without extra compensation, pipe that is not in alignment or shows excessive settlement after laying.
- Lay multiple lines of reinforced concrete pipe with the centerlines of the individual barrels parallel. Use the clear distances between outer surfaces of adjacent pipes shown in Table 5 unless otherwise shown on the plans. Use the equivalent diameter from Table 2 or Table 3 for arch pipe or horizontal elliptical pipe to determine the clear distance requirement in Table 5.

Table 5
Minimum Clear Distance between Pipes

Equivalent Diameter	Min Clear Distance
18 in.	9 in.
24 in.	11 in.
30 in.	1 ft. 1 in.
36 in.	1 ft. 3 in.
42 in.	1 ft. 5 in.
48 in.	1 ft. 7 in.
54 in.	1 ft. 11 in.
60 to 84 in.	2 ft.

- 3.3. **Jointing.** Make available an appropriate rolling device similar to an automobile mechanic's "creeper" for conveyance through small-size pipe structures.
- 3.3.1. **Joints Sealed with Hydraulic Cement Mortar.** Use Type S mortar meeting the requirements of ASTM C270. Clean and wet the pipe ends before making the joint. Plaster the lower half of the bell or groove and the upper half of the tongue or spigot with mortar. Pack mortar into the joint from both inside and outside the pipe after the pipes are tightly jointed. Finish the inside smooth and flush with adjacent joints of pipe. Form a bead of semicircular cross-section over tongue-and-groove joints outside the pipe, extending at least 1 in. on each side of the joint. Form the mortar for bell-and-spigot joints to a 45° fillet between the outer edge of the bell and the spigot. Cure mortar joints by keeping the joints wet for at least 48 hr. or until the backfill has been completed, whichever comes first. Place fill or backfill once the mortar jointing material has cured for at least 6 hr. Conduct jointing only when the atmospheric temperature is above 40°F. Protect mortared joints against freezing by backfilling or other approved methods for at least 24 hr.
- Driveway culverts do not require mortar banding on the outside of the pipe.
- Furnish pipes, with approval, that are large enough for a person to enter with the groove between 1/2 in. and 3/4 in. longer than the tongue. Such pipe may be laid and backfilled without mortar joints. Clean the space on the interior of the pipe between the end of the tongue and the groove of all foreign material, thoroughly wet and fill with mortar around the entire circumference of the pipe, and finish flush after the backfilling has been completed.
- 3.3.2. **Joints Using Cold-Applied, Plastic Asphalt Sewer Joint Compound.** Ensure both ends of the pipes are clean and dry. Trowel or otherwise place a 1/2-in. thick layer of the compound in the groove end of the pipe covering at least 2/3 of the joint face around the entire circumference. Shove home the tongue end of the next pipe with enough pressure to make a tight joint. Remove any excess mastic projecting into the pipe after the joint is made. Backfill after the joint has been inspected and approved.
- 3.3.3. **Joints Using Rubber Gaskets.** Make the joint assembly according to the recommendations of the gasket manufacturer. Make joints watertight when using rubber gaskets. Backfill after the joint has been inspected and approved.
- 3.3.4. **Joints Using Pre-Formed Flexible Joint Sealants.** Install pre-formed flexible joint sealants in accordance with the manufacturer's recommendations. Place the joint sealer so no dirt or other deleterious materials come in contact with the joint sealing material. Pull or push home the pipe with enough force to properly seal the joint. Remove any joint material pushed out into the interior of the pipe that would tend to obstruct the flow. Store pre-formed flexible joint sealants in an area warmed naturally or artificially to above 70°F in an approved manner when the atmospheric temperature is below 60°F. Apply flexible joint sealants to pipe joints immediately before placing pipe in trench, and connect pipe to previously laid pipe. Backfill after the joint has been inspected and approved.
- 3.4. **Connections and Stub Ends.** Make connections of concrete pipe to existing pipes, pipe storm drains, or storm drain appurtenances as shown on the plans.

Mortar or concrete the bottom of existing structures if necessary to eliminate any drainage pockets created by the connections. Repair any damage to the existing structure resulting from making the connections.

Make connections between concrete pipe and corrugated metal pipe with a suitable concrete collar and a minimum thickness of 4 in. unless otherwise shown on the plans.

Finish stub ends for connections to future work not shown on the plans by installing watertight plugs into the free end of the pipe.

Fill lift holes with concrete, mortar, or precast concrete plugs after the pipe is in place.

4. MEASUREMENT

This Item will be measured by the foot. Measurement will be made between the ends of the pipe barrel along the flow line, not including safety end treatments. Safety end treatments will be measured in accordance with Item 467, "Safety End Treatment." Pipe that will be jacked, bored, or tunneled will be measured in accordance with Item 476, "Jacking, Boring, or Tunneling Pipe or Box." Measurement of spurs, branches, or new connecting pipe will be made from the intersection of the flow line with the outside surface of the pipe into which it connects. Where inlets, headwalls, catch basins, manholes, junction chambers, or other structures are included in lines of pipe, the length of pipe tying into the structure wall will be included for measurement, but no other portion of the structure length or width will be included.

For multiple pipes, the measured length will be the sum of the lengths of the barrels.

This is a plans quantity measurement Item. The quantity to be paid is the quantity shown in the proposal unless modified by Article 9.2., "Plans Quantity Measurement." Additional measurements or calculations will be made if adjustments of quantities are required.

5. PAYMENT

The work performed and materials furnished in accordance with this Item and measured as provided under "Measurement" will be paid for at the unit price bid for "Reinforced Concrete Pipe," "Reinforced Concrete Pipe (Arch)," or "Reinforced Concrete Pipe (Elliptical)" of the size and D-load specified or of the size and class specified. This price is full compensation for constructing, furnishing, transporting, placing, and joining pipes; shaping the bed; cutting pipes on skew or slope; connecting to new or existing structures; breaking back, removing, and disposing of portions of the existing structure; replacing portions of the existing structure; cutting pipe ends on skew or slope; and equipment, labor, tools, and incidentals.

Protection methods for excavations greater than 5 ft. deep will be measured and paid for as required under Item 402, "Trench Excavation Protection," or Item 403, "Temporary Special Shoring." Excavation, shaping, bedding, and backfill will be paid for in accordance with Item 400, "Excavation and Backfill for Structures." When jacking, boring, or tunneling is used at the Contractor's option, payment will be made under this Item. When jacking, boring or tunneling is required, payment will be made under Item 476, "Jacking, Boring or Tunneling Pipe or Box."

Item 465

Junction Boxes, Manholes, and Inlets



1. DESCRIPTION

Construct junction boxes, manholes, and inlets, complete in place or to the stage detailed, including furnishing and installing frames, grates, rings, and covers.

2. MATERIALS

Furnish materials in accordance with the following:

- Item 420, "Concrete Substructures,"
- Item 421, "Hydraulic Cement Concrete,"
- Item 440, "Reinforcement for Concrete," and
- Item 471, "Frames, Grates, Rings, and Covers."

Cast-in-place junction boxes, manholes, inlets, risers, and appurtenances are acceptable unless otherwise shown. Alternate designs for cast-in-place items must be acceptable to the Engineer and must conform to functional dimensions and design loading. Alternate designs must be designed and sealed by a licensed professional engineer.

- 2.1. **Concrete.** Furnish Class H concrete as referenced in Item 421 "Hydraulic Cement Concrete," except that Mix Design Options 1–8 will be allowed for formed precast junction boxes, manholes, and inlets. Furnish concrete per DMS-7310, "Reinforced Concrete Pipe and Machine-Made Precast Concrete Box Culvert Fabrication and Plant Qualification," for machine-made precast junction boxes, manholes, and inlets. Furnish Class C concrete for cast-in-place manholes and inlets unless otherwise shown on the plans.
- 2.2. **Mortar.** Furnish mortar conforming to DMS-4675, "Cementitious Grouts and Mortars for Miscellaneous Applications."
- 2.3. **Timber.** Provide sound timber that is a minimum of 3 in. nominal thickness and reasonably free of knots and warps for temporary covers when used with Stage I construction (see Article 465.3., "Construction").
- 2.4. **Other Materials.** Use commercial-type hardware as approved.

3. CONSTRUCTION

Construct all types of junction boxes, manholes, and inlets either complete or in 2 stages, described as Stage I and Stage II.

Construct the Stage I portion of junction boxes, manholes, and inlets as shown on the plans or as specified in this Item. Furnish and install a temporary cover as approved.

Furnish and install the storm drain pipe and a temporary plug for the exposed end of the storm drain pipe from the storm drain to a point below the top of curb indicated on the plans for Stage I construction of cast iron or steel inlet units.

Construct Stage II after the pavement structure is substantially complete unless otherwise approved.

Construct the remaining wall height and top of junction box, manhole, or inlet for Stage II, and furnish and install any frames, grates, rings and covers, curb beams, or collecting basins required.

Construct cast-in-place junction boxes, manholes, and inlets in accordance with Item 420, "Concrete Substructures." Forms will be required for all concrete walls. Outside wall forms for cast-in-place concrete may be omitted with approval if the surrounding material can be trimmed to a smooth vertical face.

- 3.1. **Precast Junction Boxes, Manholes, and Inlets.** Construct formed precast junction boxes, manholes, and inlets in accordance with Item 420, "Concrete Substructures," except as otherwise noted in this Item. Construct machine-made precast junction boxes, manholes, and inlets in accordance with ASTM C478 except as otherwise noted in this Item. Mix and place concrete for machine-made junction boxes, manholes, and inlets per the requirements of DMS-7310, "Reinforced Concrete Pipe and Machine-Made Precast Concrete Box Culvert Fabrication and Plant Qualification." Conform to the product permissible variations and rejection criteria stated in ASTM C478 for machine-made precast junction boxes, manholes, and inlets. Cure all precast units in accordance with Item 424, "Precast Concrete Structural Members (Fabrication)."
- Multi-project fabrication plants as defined in Item 424 "Precast Concrete Structural Members (Fabrication)," that produce manholes and inlets will be approved by the Construction Division in accordance with DMS-7340, "Qualification Procedure for Multi-Project Fabrication Plants of Precast Concrete Junction Boxes, Manholes and Inlets." The Department's MPL has a list of approved multi-project plants.
- 3.1.1. **Lifting Holes.** Provide no more than 4 lifting holes in each section for precast units. Lifting holes may be cast, cut into fresh concrete after form removal, or drilled. Provide lifting holes large enough for adequate lifting devices based on the size and weight of the section. The maximum hole diameter is 3 in. at the inside surface of the wall and 4 in. at the outside surface. Cut no more than 5 in. in any direction of reinforcement per layer for lifting holes. Repair spalled areas around lifting holes.
- 3.1.2. **Marking.** Clearly mark each precast junction box, manhole, and inlet unit with the following information:
- name or trademark of fabricator and plant location;
 - product designation;
 - ASTM designation (if applicable);
 - date of manufacture;
 - designated fabricator's approval stamp; and
 - designation "SR" for product meeting sulfate-resistant concrete plan requirements (when applicable).
- 3.1.3. **Storage and Shipment.** Store precast units on a level surface. Do not ship units until design strength requirements have been met.
- 3.2. **Excavation, Shaping, Bedding, and Backfill.** Excavate, shape, bed, and backfill in accordance with Item 400, "Excavation and Backfill for Structures." Immediate backfilling is permitted for all junction box, manhole, and inlet structures where joints consist of rubber boots, rubber gaskets, or bulk or preformed joint sealant. Take precautions in placing and compacting the backfill to avoid any movement of junction boxes, manholes, and inlets. Remove and replace junction boxes, manholes, and inlets damaged by the Contractor at no expense to the Department.
- 3.3. **Junction Boxes, Manholes, and Inlets for Precast Concrete Pipe Storm Drains.** Construct junction boxes, manholes, and inlets for precast concrete pipe storm drains before completion of storm drain lines into or through the junction box, manhole, or inlet. Neatly cut all storm drains at the inside face of the walls of the junction box, manhole, or inlet.
- 3.4. **Junction Boxes, Manholes, and Inlets for Box Storm Drains.** Place bases or risers of junction boxes, manholes, and inlets for box storm drains before or in conjunction with placement of the storm drain. Backfill the junction box, manhole, or inlet and storm drain as a whole.
- 3.5. **Inverts.** Shape and route floor inverts passing out or through the junction box, manhole, or inlet as shown on the plans. Shape by adding and shaping mortar or concrete after the base is placed or by placing the required additional material with the base.

- 3.6. **Finishing Complete Junction Boxes, Manholes, and Inlets.** Complete junction boxes, manholes, and inlets in accordance with the plans. Backfill to original ground elevation in accordance with Item 400, "Excavation and Backfill for Structures."
- 3.7. **Finishing Stage I Construction.** Complete Stage I construction by constructing the walls to the elevations shown on the plans and backfilling to required elevations in accordance with Item 400, "Excavation and Backfill for Structures."
- 3.8. **Stage II Construction.** Construct subgrade and base course or concrete pavement construction over Stage I junction box, manhole, or inlet construction unless otherwise approved. Excavate to expose the top of Stage I construction and complete the junction box, manhole or inlet in accordance with the plans and these Specifications, including backfill and cleaning of all debris from the bottom of the junction box, manhole, or inlet.
- 3.9. **Inlet Units.** Install cast iron or steel inlet units in conjunction with the construction of concrete curb and gutter. Set the inlet units securely in position before placing concrete for curb and gutter. Form openings for the inlets and recesses in curb and gutter as shown on the plans. Place and thoroughly consolidate concrete for curb and gutter adjacent to inlets and around the inlet castings and formed openings and recesses without displacing the inlet units.

4. MEASUREMENT

All junction boxes, manholes, and inlets satisfactorily completed in accordance with the plans and specifications will be measured by each junction box, manhole, or inlet, complete, or by each junction box, manhole, or inlet completed to the stage of construction required by the plans.

5. PAYMENT

The work performed and materials furnished in accordance with this Item and measured as provided under "Measurement" will be paid for as follows:

- 5.1. **Complete Manholes.** Payment for complete manholes will be made at the unit price bid for "Manhole (Complete)" of the type specified.
- 5.2. **Complete Inlets.** Payment for inlets will be made at the unit price bid for "Inlet (Complete)," of the type specified.
- 5.3. **Complete Junction Boxes.** Payment for junction boxes will be made at the unit price bid for "Junction Box (Complete)" of the type specified.
- 5.4. **Manholes Stage I.** Payment for Manholes, Stage I, will be made at the unit price bid for each "Manhole (Stage I)" of the type specified.
- 5.5. **Manholes Stage II.** Payment for Manholes, Stage II, will be made at the unit price bid for each "Manhole (Stage II)" of the type specified.
- 5.6. **Inlets Stage I.** Payment for Inlets, Stage I, will be made at the unit price bid for each "Inlet (Stage I)" of the type specified.
- 5.7. **Inlets Stage II.** Payment for Inlets, Stage II, will be made at the unit price bid for each "Inlet (Stage II)" of the type specified.
- 5.8. **Junction Boxes Stage I.** Payment for Junction Boxes, Stage I, will be made at the unit price bid for each "Junction Box (Stage I)" of the type specified.

- 5.9. **Junction Boxes Stage II.** Payment for Junction Boxes, Stage II, will be made at the unit price bid for each "Junction Box (Stage II)" of the type specified.

This price is full compensation for concrete, reinforcing steel, mortar, frames, grates, rings and covers, excavation, and backfill and for all other materials, tools, equipment, labor, and incidentals.

Item 466

Headwalls and Wingwalls



1. DESCRIPTION

Furnish, construct, and install concrete headwalls and wingwalls for drainage structures and underpasses.

2. MATERIALS

2.1. **General.** Furnish materials in accordance with the following.

- Item 420, "Concrete Substructures,"
- Item 421, "Hydraulic Cement Concrete," and
- Item 440, "Reinforcement for Concrete."

Use Class C concrete for cast-in-place and precast concrete units unless otherwise shown on the plans. Furnish cast-in-place or precast headwalls and wingwalls unless otherwise shown on the plans.

2.2. **Fabrication.**

2.2.1. **General.** Fabricate cast-in-place concrete units and precast units in accordance with Item 420 "Concrete Substructures." Use the following definitions for headwalls and wingwalls:

- "Headwalls" refers to all walls, including wings, at the ends of single-barrel and multiple-barrel pipe culvert structures.
- "Wingwalls" refers to all walls at the ends of single-barrel or multiple-barrel box culvert structures.

2.2.2. **Lifting Holes.** Provide no more than 4 lifting holes in each section for precast units. Lifting holes may be cast, cut into fresh concrete after form removal, or drilled. Provide lifting holes large enough for adequate lifting devices based on the size and weight of the section. The maximum hole diameter is 3 in. at the inside surface of the wall and 4 in. at the outside surface. Cut no more than 1 longitudinal wire or 2 circumferential wires per layer of reinforcing steel when locating lift holes. Repair spalled areas around lifting holes.

2.2.3. **Marking.** Clearly mark each precast unit before shipment from the casting or fabrication yard with the following:

- the date of manufacture,
- the name or trademark of the manufacturer, and
- the type and size designation.

2.2.4. **Storage and Shipment.** Store precast units on a level surface. Do not place any loads on precast concrete units until design strength is reached. Do not ship units until design strength requirements have been met.

2.2.5. **Causes for Rejection.** Precast units may be rejected for not meeting any one of the specification requirements. Individual units may also be rejected for fractures or cracks passing through the wall or surface defects indicating honeycombed or open texture surfaces. Remove rejected units from the project, and replace them with acceptable units meeting the requirements of this Item.

2.2.6. **Defects and Repairs.** Occasional imperfections in manufacture or accidental damage sustained during handling may be repaired. The repaired units will be acceptable if they conform to the requirements of this Item and the repairs are sound, properly finished, and cured in conformance with pertinent specifications.

3. CONSTRUCTION

- 3.1. **General.** Remove portions of existing structures and drill, dowel, and grout in accordance with Item 420, "Concrete Substructures."
- 3.2. **Excavation, Shaping, Bedding, and Backfill.** Excavate, shape, bed, and backfill in accordance with Item 400, "Excavation and Backfill for Structures." Take special precautions in placing and compacting the backfill to avoid any movement or damage to the units. Bed precast units on foundations of firm and stable material accurately shaped to conform to the bases of the units.
- 3.3. **Placement of Precast Units.** Provide adequate means to lift and place the precast units. Fill lifting holes with mortar or concrete and cure. Precast concrete or mortar plugs may be used.
- 3.4. **Connections.** Make connections to new or existing structures in accordance with the details shown on the plans. Furnish jointing material in accordance with Item 464, "Reinforced Concrete Pipe," or as shown on the plans.

Remove a length of the existing pipe from the headwall to the joint when removing existing headwalls as shown on the plans or as approved. Re-lay the removed pipe if approved, or furnish and lay a length of new pipe.

4. MEASUREMENT

This is a plans quantity measurement item. The quantity to be paid is the quantity shown in the proposal unless modified by Article 9.2., "Plans Quantity Measurement." Additional measurements or calculations will be made if adjustments of quantities are required.

- 4.1. **Headwalls.** Headwalls will be measured by each end of a structure.
- 4.2. **Wingwalls.** Wingwalls will be measured by one of the following methods:
- 4.2.1. **Square Foot.** Wingwalls will be measured by the square foot of the front surface area of the wall of each type. The area will be measured from the top of the footing or apron to the top of the wall unless otherwise shown on the plans. If there is no footing or apron, then measurement is from the bottom of the wall.
- 4.2.2. **Each.** Wingwalls will be measured by each end of a structure.

5. PAYMENT

The work performed and materials furnished in accordance with this Item and measured as provided under "Measurement" will be paid for at the price bid for "Headwalls" of the type and pipe size (diameter or design) specified, "Wingwalls" of the type specified when measurement is by the square foot, or "Wingwalls" of the type and wall height specified when measurement is by each. For payment purposes, the wingwall height will be rounded to the nearest foot. All wingwalls and headwalls of the same type will be paid for equally when skew does not affect the type. This price is full compensation for constructing, furnishing, transporting, and installing the headwalls or wingwalls; connecting to existing structure; breaking back, removing and disposing of portions of the existing structure, and replacing portions of the existing structure as required to make connections; excavation and backfill; and concrete, reinforcing steel, corrugated metal pipe or reinforced concrete pipe, equipment, labor, tools, and incidentals.

Apron concrete or riprap between or around the wingwalls of single- or multiple-barrel box culvert structures will be measured and paid for in accordance with Item 432, "Riprap."

The removal and re-laying of existing pipe or the furnishing of new pipe to replace existing pipe will not be paid for directly but will be considered subsidiary to this Item.

Item 467

Safety End Treatment



1. DESCRIPTION

Furnish, construct, and install safety end treatments for drainage structures, or install or replace pipe runners or pipe runner assemblies on existing drainage structures.

2. MATERIALS

2.1. **General.** Furnish materials in accordance with the following.

- Item 420, "Concrete Substructures,"
- Item 421, "Hydraulic Cement Concrete,"
- Item 432, "Riprap,"
- Item 440, "Reinforcement for Concrete,"
- Item 442, "Metal for Structures,"
- Item 445, "Galvanizing,"
- Item 460, "Corrugated Metal Pipe," and
- Item 464, "Reinforced Concrete Pipe."

Use Class C concrete for cast-in-place and precast concrete units unless otherwise shown on the plans. Furnish cast-in-place or precast safety end treatments unless otherwise shown on the plans. Furnish Class B concrete for concrete riprap unless otherwise shown on the plans. Provide galvanized steel for prefabricated metal end sections in accordance with Item 460, "Corrugated Metal Pipe."

Furnish pipe runners in accordance with the following:

- ASTM A1085;
- ASTM A53, Type E or S, Grade B;
- ASTM A500, Grade B; or
- API 5L, Grade X42.

Furnish plates and angles in accordance with ASTM A36. Furnish nuts and bolts in accordance with ASTM A307. Galvanize pipes, plates, angles, nuts, and bolts in accordance with Item 445, "Galvanizing."

2.2. **Fabrication.** Fabricate cast-in-place concrete units and precast units in accordance with Item 420, "Concrete Substructures." Provide either prefabricated metal end sections or mitered CMP when specified for the pipe structure unless otherwise shown on the plans.

Provide one of the following when reinforced concrete pipe (RCP) is specified for the pipe structure, unless otherwise shown on the plans:

- mitered RCP or
- precast safety end treatment (SET) units. Provide riprap only if the plans specifically require it for this alternative.

2.2.1. **SET Types.**

2.2.1.1. **Type I.** Provide Type I SET consisting of reinforced concrete headwalls or wingwalls and pipe runners in accordance with the details shown on the plans when required.

- 2.2.1.2. **Type II.** Provide Type II SET in accordance with the details shown on the plans consisting of the following:
- CMP or RCP mitered to the proper slope, concrete riprap and pipe runners, when required;
 - prefabricated metal end sections, concrete riprap and pipe runners, when required; or
 - precast SET units, concrete riprap, when required, and pipe runners, when required.
- 2.2.2. **Lifting Holes.** Provide no more than 4 lifting holes in each section for precast units. Lifting holes may be cast, cut into fresh concrete after form removal, or drilled. Provide lifting holes large enough for adequate lifting devices based on the size and weight of the section. The maximum hole diameter is 3 in. at the inside surface of the wall and 4 in. at the outside surface. Cut no more than 1 longitudinal wire or 2 circumferential wires per layer of reinforcing steel when locating lift holes. Repair spalled areas around lifting holes.
- 2.2.3. **Marking.** Clearly mark the following on each precast unit, mitered CMP, mitered RCP, or metal end section before shipment from the casting or fabrication yard:
- the date of manufacture,
 - the name or trademark of the manufacturer, and
 - the type and size designation.
- 2.2.4. **Storage and Shipment.** Store precast units on a level surface. Do not place any loads on precast units until the design strength is reached. Do not ship units until design strength requirements have been met.
- 2.2.5. **Causes for Rejection.** Precast units may be rejected for not meeting any one of the specification requirements. Individual units may also be rejected for fractures or cracks passing through the wall or surface defects indicating honeycombed or open texture surfaces. Remove rejected units from the project and replace with acceptable units meeting the requirements of this Item.
- 2.2.6. **Defects and Repairs.** Occasional imperfections in manufacture or accidental damage sustained during handling may be repaired. The repaired units will be acceptable if they conform to the requirements of this Item and the repairs are sound and properly finished and cured in conformance with pertinent specifications. Repair damaged galvanizing in accordance with Section 445.3.5., "Repairs."

3. CONSTRUCTION

- 3.1. **General.** Remove portions of existing structures in accordance with Section 420.4.8., "Extending Existing Substructures." Drill, dowel, and grout in accordance with Item 420, "Concrete Substructures." Furnish concrete riprap in accordance with Item 432, "Riprap."
- Provide riprap on all prefabricated metal end sections.
- 3.2. **Excavation, Shaping, Bedding, and Backfill.** Excavate, shape, bed, and backfill in accordance with Item 400, "Excavation and Backfill for Structures." Take special precautions in placing and compacting the backfill to avoid any movement or damage to the units. Bed precast units on foundations of firm and stable material accurately shaped to conform to the bases of the units.
- 3.3. **Placement of Precast Units.** Provide adequate means to lift and place the precast units. Fill lifting holes with mortar or concrete and cure. Precast concrete or mortar plugs may be used.
- 3.4. **Connections.** Make connections to new or existing structures in accordance with the details shown on the plans. Furnish jointing material in accordance with Item 464, "Reinforced Concrete Pipe."
- Also remove a length of the existing pipe from the headwall to the joint when removing existing headwalls as shown on the plans or as approved. Re-lay the removed pipe if approved, or furnish and lay a length of new pipe.
- 3.5. **Install or Replace Pipe Runners or Assemblies.** Install or replace individual pipe runners or pipe runner assemblies on existing drainage structures as indicated on the plans.

4. MEASUREMENT

SETs of all types will be measured by each barrel of each structure end.

Pipe runners or pipe runner assemblies installed or replaced on existing structure will be measured by each installed or replaced on each structure end.

5. PAYMENT

The work performed and materials furnished in accordance with this Item and measured as provided under "Measurement" will be paid for at the unit price bid for the various designations of "Safety End Treatment" specified as follows:

- SET (Type I) (Barrel Span) (Wall Height) (Slope, Horizontal:Vertical) (Orientation, Cross or Parallel)
- SET (Type I) (Pipe Diameter or Design) (Slope, Horizontal:Vertical) (Orientation, Cross or Parallel)
- SET (Type II) (Pipe Diameter or Design) (Pipe Material) (Slope, Horizontal:Vertical) (Orientation, Cross or Parallel)
- SET (Pipe Runner)
- SET (Pipe Runner Assembly)

For payment purposes, the wingwall heights of Type I SETs for box culverts will be rounded to the nearest foot.

This price is full compensation for constructing, furnishing, transporting, and installing the end treatments; pipe runners, or pipe runner assemblies, connecting to existing structure; breaking back, removing and disposing of portions of the existing structure, removing and disposing of existing pipe runner or pipe runner assemblies, and replacing portions of the existing structure as required to make connections; excavation and backfill; furnishing concrete, reinforcing steel, corrugated metal pipe or reinforced concrete pipe, and pipe runners; and concrete riprap, nuts, bolts, plates, angles, equipment, labor, tools, and incidentals.

The removal and re-laying of existing pipe or the furnishing of new pipe to replace existing pipe will not be paid for directly but will be considered subsidiary to this Item.

The mitered length of CMP or RCP that is a part of the SET (Type II) will not be paid for directly but will be considered subsidiary to this Item. The limits for payment for pipe will be as shown on the plans and paid for in accordance with the pertinent bid item.

The limits of riprap to be included in the price bid for each SET will be shown on the plans. Any riprap placed beyond the limits shown will be paid in accordance with Item 432, "Riprap." Riprap between multiple precast SET units will be required as shown on the plans and is included in the price bid for SET.

When precast SETs are provided as an option to mitered RCP, riprap aprons will not be required unless the plans specifically require riprap aprons for precast SET units. The plans will show the limits of the riprap to be included with the precast SET for payment.

Item 471

Frames, Grates, Rings, and Covers



1. DESCRIPTION

Furnish and install frames, grates, rings, and covers for inlets, manholes, and other structures.

2. MATERIALS

- 2.1. **Frame, Grate, Ring, and Cover Castings.** Provide clean castings conforming to the shape and dimensions shown on the plans. Ensure all gray and ductile iron castings conform to the AASHTO Designation M 306. Cast or machine the bearing surfaces for traffic service castings between manhole rings and covers and between grates and frames with such precision as to prevent rocking.

Provide gray iron castings in accordance with ASTM A48 Class 35B and AASHTO M 306 for traffic service applications unless otherwise specified. Provide gray iron castings in accordance with ASTM A48 Class 35B for sidewalk or pedestrian applications unless otherwise specified. Provide ductile iron castings in accordance with ASTM A536, Grade 70-50-05, unless otherwise specified. Provide steel castings in accordance with ASTM A27, Grade 70-36, unless otherwise specified. Ensure all traffic service castings and gratings meet or exceed the H20 proof-load requirements of AASHTO M 306. Load test results and material certifications must be made available upon request.

Ensure all traffic service (heavy duty) rated castings and grating meet the proof-load testing requirements of AASHTO M 306. Ensure all load tests are conducted with a calibrated NIST certified load cell. Ensure materials are loaded with a 9 × 9-in. load block to an applied load of 40,000 lb. for one minute without deformation or failure. Load test results and material certifications must be made available upon request.

Provide castings within $\pm 1/16$ in. per foot of plan dimensions, and within $\pm 5\%$ of plan weight.

- 2.2. **Welded Steel Grates and Frames.** Provide welded steel grates and frames as an assembly in accordance with the member size, dimensions, and details shown on the plans. Fabricate these assemblies in accordance with Item 441, "Steel Structures." Use steel that meets ASTM A36 or equivalent.

- 2.3. **Documentation.** Furnish a manufacturer's certification stating the casting meets the proof-load testing requirements of AASHTO M 306 for traffic service castings.

3. CONSTRUCTION

Construct and install frames, grates, rings, and covers in accordance with the details shown on the plans. Weld in accordance with Item 448, "Structural Field Welding." Tack weld grates and covers to the frame or ring when directed.

Galvanize steel castings, welded steel grates, and frames in accordance with Item 445, "Galvanizing." Galvanizing is not required for iron castings unless used in conjunction with structural steel shapes or shown on the plans.

Provide galvanized bolts and nuts in accordance with Item 445, "Galvanizing."

4. MEASUREMENT

Frames, grates, rings, and covers, when a part of the complete manhole or inlet, will not be measured for payment but will be considered subsidiary to Item 465, "Junction Boxes, Manholes, and Inlets." Frames, grates, rings, and covers, when not a part of a Manhole (complete) or Inlet (complete), will be measured by the each.

5. PAYMENT

When payment is required in accordance with "Measurement," payment for frames, grates, rings, and covers will be made at the unit price bid for "Grate," "Frame," "Grate and Frame," "Frame and Cover," or "Ring and Cover" with the type and number of grates specified, if necessary. This price is full compensation for equipment, materials, labor, tools, and incidentals.

Item 472

Removing and Re-Laying Culvert



1. DESCRIPTION

Remove, transport, clean, and re-lay existing culvert and storm drain pipe.

2. MATERIALS

Bituminous coating must meet the requirements of Section 460.2.2., "Protective Coating."

3. CONSTRUCTION

Culvert and storm drain pipe to be removed and re-laid will be shown on the plans. Remove debris and sediment within the culvert and storm drain pipe. Clean joints to facilitate proper re-laying. Install concrete pipe in accordance with Item 464, "Reinforced Concrete Pipe." Install corrugated metal pipe in accordance with Item 460, "Corrugated Metal Pipe." Excavate, bed, and backfill in accordance with Item 400, "Excavation and Backfill for Structures." Prevent damage to the pipe and fittings. Make connections to existing structures as shown on the plans and in conformance to the requirements for connections as described in pertinent pipe specifications. Connect reinforced concrete pipe to corrugated metal pipe with a suitable concrete collar with a minimum thickness of 4 in. or as shown on the plans. Use a coating of bituminous material to insulate portions of aluminum pipe that are to be in contact with metal other than aluminum. Extend coating at least 1 ft. beyond area of contact. Mark the top and bottom of reinforced concrete pipe before removal and reinstall in the same position. Reuse headwall, aprons, or other appurtenances by severing from the culvert and moving to the new position if shown on the plans. Make connections for joining sections of pipes in accordance with pertinent Items.

Replace any items designated for reuse with new material or restore them to previous condition, as approved. The Contractor may remove and dispose of existing structures and construct new structures at no expense to the Department in accordance with pertinent specifications and designs shown on the plans or as approved.

4. MEASUREMENT

This Item will be measured by the foot between the ends of the pipe barrel along the flow line as installed. Where spurs, branches, or connections to the existing pipe lines are involved, measurement of the spur or connecting pipe will be made from the intersection at the flow line with the outside surface of the pipe into which the pipe connects. Where inlets, catch basins, manholes, safety end treatments, or other structures are included in lines of pipe, the length of pipe tying into the structure wall will be included for measurement but no other portion of the structure length or width will be included.

5. PAYMENT

The work performed and materials furnished in accordance with this Item and measurement as provided under "Measurement" will be paid for at the unit price bid for "Removing and Re-laying Pipe" of the size specified. This price is full compensation for excavating and removing pipe from its original location; loading, hauling, placing, and joining pipe; cutting pipe ends on skew or slope; moving and re-using headwalls and safety end treatments; connections to existing structures; concrete collars and reinforcing; and equipment, materials, labor, tools, and incidentals. Removal and disposal of pipe and appurtenances not reused will be subsidiary to the bid items of the Contract. Protection methods for excavations greater than 5 ft. in depth will be measured and paid for as required under Item 402, "Trench Excavation Protection," or Item 403,

"Temporary Special Shoring." Excavation, bedding, and backfill for re-laying pipe will be paid for in accordance with Item 400, "Excavation and Backfill for Structures." When jacking, boring, or tunneling is used at the Contractor's option, payment will be made under this Item. When jacking, boring, or tunneling is required, payment will be made under Item 476, "Jacking, Boring, or Tunneling Pipe or Box."

Item 474

Linear Drains



1. DESCRIPTION

Furnish and install linear drains of the sizes and descriptions shown on the plans as cast-in-place trench drain, precast trench drain, or slotted drain.

2. MATERIALS

Provide materials conforming to the pertinent requirements of the following Items:

- 2.1. **Cast-in-Place Trench Drain.** Provide a trench with a slope as shown on the plans. Furnish forms capable of maintaining proper alignment during the concrete placement. Ensure connections to structures do not restrict the hydraulic flow of the trench drain. Use Class C Concrete conforming to Item 421, "Hydraulic Cement Concrete."

Provide grates and frames conforming to the requirements of DMS-4370.6 (B), "Grates and Frames." Removable grates with minimum width of 12 in. and length of 36 in. are permissible. Grates with lessor dimensions will not be removable.

Provide shop drawings sealed by a licensed professional engineer stating the trench drain system meets loading requirements. Submit documents showing design loadings if using a proprietary system.

Furnish documentation in accordance with Section 471.2.3., "Documentation."

- 2.2. **Precast Trench Drains.** Furnish precast trench drains for the Department from pre-approved manufacturers in accordance with DMS-4370, "Precast Trench Drain." The Department's MPL is a list of approved manufacturers and their products. Unapproved precast trench drains will not be accepted.

Furnish materials conforming to the following where required.

- Item 420, "Concrete Substructures"
- Item 421, "Hydraulic Cement Concrete" (Use Class C concrete unless otherwise shown on the plans.), and
- Item 440, "Reinforcement for Concrete."

- 2.3. **Slotted Drains.** Fabricate and furnish materials in accordance with Item 460, "Corrugated Metal Pipe." Furnish galvanized steel or aluminized steel (AASHTO M 36, Type 2) pipe with a minimum thickness of 16 gauge.

Slotted drains consist of a drain guide assembly attached to a longitudinal opening in a corrugated metal pipe. Unless otherwise specified on the plans, fabricate slotted drains with bearing bars and crossbar spacers meeting the requirements of ASTM A 36, welded to the longitudinal opening in the corrugated metal pipe. Galvanize the drain guide assembly after fabrication in accordance with Item 445, "Galvanizing." Clean and repair welded areas and heat-affected zones in accordance with Section 445.3.5, "Repairs."

- 2.4. **Slotted Drain Outfalls.** Slotted drain outfalls consist of the corrugated metal pipe that connects the slotted drain to the main drainage line.

- 2.5. **Backfill.** Provide cement-stabilized backfill in accordance with Item 400, "Excavation and Backfill for Structures," or high-slump, low-strength concrete with a minimum of 180 lb. of cement per cubic yard.

3. CONSTRUCTION OF CAST IN PLACE TRENCH DRAINS

Perform excavation in accordance with Item 400, "Excavation and Backfill for Structures." Construct trench with a slope as shown on the plans. Submit shop drawings that provide enough detail to ensure seamless installation of the trench drain adjacent to the proposed or existing pavement structure.

If using a proprietary system, provide shop drawings that contain the manufacturer's installation guidelines and any sequential order of construction. Construct the trench drain with a maximum allowable tolerance of $\pm 1/16$ in. for dimensional accuracy and rail co-planarity. Provide a smooth finish on the surface of the trench that will convey runoff. Make connections to new or existing structures as shown on the plans or as directed.

Remove trench drain forms and dispose of properly. Install grates with retaining pins on each of the 4 corners. Remove all construction debris from the trench drain.

4. CONSTRUCTION OF PRECAST TRENCH DRAINS

Place precast trench drains in concrete pavement or encased in a concrete grade beam and subgrade designed to support H-20 wheel loading.

Perform excavation in accordance with Item 400, "Excavation and Backfill for Structures." Construct trench with a slope as shown on the plans. Use interconnecting end profiles on adjoining channels to maintain channel alignment within $\pm 1/16$ in. Use non-sloping sections where shown on the plans or as directed.

Assemble and install precast trench drains in accordance with approved shop drawings and manufacturer's recommendations at the locations directed on the plans. Provide shop drawings containing the manufacturer's installation guidelines.

Encase precast trench drains, not cast in concrete pavement, in concrete grade beams, as shown on the plans and suitable to support the trench drain and retain the trench grate from pull out. Ensure the grade and alignment of the installed grates matches the grade and alignment of the surrounding pavement.

Do not provide removable trench drain grates at any location where wheeled vehicles may drive over them including roadway lanes, shoulders, and driveways.

Remove all construction debris from the trench drain.

5. CONSTRUCTION OF SLOTTED DRAINS

Install slotted drains and slotted drain outfalls in accordance with details on the plans and the requirements of Item 460, "Corrugated Metal Pipe." Excavate and backfill in accordance with Item 400, "Excavation and Backfill for Structures." Backfill trenches as shown on the plans or as directed. Furnish slotted drains in 20-ft. lengths, minimizing the number of joints required.

6. MEASUREMENT

This Item will be measured by the foot, between the ends of the linear drain along the pavement surface as installed, complete and in place. Where inlets are included in lines of linear drain, that length of drain tying into the structure wall will be included for measurements, but no other portion of the structure length or width will be included.

7. PAYMENT

The work performed and materials furnished in accordance with this Item and measured as provided under "Measurement" will be paid for at the unit price bid for "Cast-in-Place Trench Drain," "Precast Trench Drain

(in Concrete Pavement), "Precast Trench Drain (without Concrete Pavement)," or "Slotted Drain" of the size specified.

This price will be full compensation for structure excavation, installing the trench drain, concrete, reinforcing steel, reinforcement anchors, other connecting devices, furnishing all materials (including forms, rails, anchorages, support bars, and grates), tools, labor, equipment, and incidentals.

Item 476

Jacking, Boring, or Tunneling Pipe or Box



1. DESCRIPTION

Furnish and install pipe or box by jacking, boring, or tunneling.

2. MATERIALS

Use the following types of pipe or box:

- corrugated metal pipe meeting Item 460, "Corrugated Metal Pipe," of the size, type, design, and dimension shown on the plans;
- reinforced concrete pipe meeting the special requirements for jacking, boring, or tunneling of Item 464, "Reinforced Concrete Pipe," of the size, strength, and dimension shown on the plans;
- reinforced concrete box meeting Item 462, "Concrete Box Culverts and Drains," of the size and type shown on the plans; or
- other types specified by the plans.

3. CONSTRUCTION

Excavate suitable shafts or trenches for conducting the jacking, boring, or tunneling operations and for placing end joints of the pipe or box if the grade at the jacking, boring, or tunneling end is below the ground surface. Maintain a 3:1 slope from edge of pavement on the shaft side of the road unless otherwise shown or directed. Provide a positive barrier when the shaft location is within the clear zone of the roadway. Protect excavations deeper than 5 ft. as specified in Item 402, "Trench Excavation Protection," or Item 403, "Temporary Special Shoring."

Install pipe or box so there is no interference with the operation of street, highway, railroad, or other facility and no embankment or structure is weakened or damaged.

Repair any pipe or box damaged in jacking, boring, or tunneling. Remove and replace any pipe or box damaged beyond repair at the Contractor's expense.

Backfill shafts or trenches excavated to facilitate jacking, boring, or tunneling immediately after installation of pipe or box.

- 3.1. **Jacking.** Provide jacks suitable for forcing the pipe or box through the embankment. Use even pressure to all jacks during operation. Provide a suitable jacking head and suitable bracing between the jacks and the jacking head to apply uniform pressure around the ring of the pipe or circumference of the box. Use joint cushioning of plywood or other approved material. For plywood cushioning material, use 1/2-in. minimum thickness for pipe diameter 30 in. or less, and use 3/4-in. minimum thickness for pipe diameter greater than 30 in. Use 3/4-in. minimum thickness for all boxes. Use cushioning rings of single or multiple pieces. Provide a suitable jacking frame or backstop. Set the pipe or box to be jacked on guides that support the section of the pipe or box, and direct it on the proper line and grade. Place the entire jacking assembly in line with the direction and grade of the pipe or box. In general, excavate the embankment material just ahead of the pipe or box, remove the material through the pipe or box, and force the pipe or box through the embankment with jacks into the space bored or tunneled.

Furnish a plan showing the proposed method of jacking for approval. Include the design for the jacking head, jacking support or backstop (thrust block), arrangement and position of jacks, and guides in the plan.

Ensure excavation for the underside of the pipe for at least 1/3 of the circumference of the pipe conforms to the contour and grade of the pipe. Ensure the excavation for the bottom slab of the box conforms to the grade of the box. Over-excavate, if desired, to provide no more than 2 in. of clearance for the upper portion and sides of the pipe or box. Taper this clearance to zero at the point where the excavation conforms to the contour of the pipe or box. Carry out jacking without interruption to prevent the pipe from becoming firmly set in the embankment. Monitor volume of soil excavated to avoid any appreciable over excavation. Pressure-grout any over excavation of more than 1 in. Pressure-grout between the carrier pipe and casing when shown on the plans.

The distance the excavation extends beyond the end of the pipe or box must not exceed 2 ft. Decrease this distance as necessary to maintain stability of the material being excavated.

Jack the pipe or box from the low or downstream end. The final position of the pipe or box must not vary from the line and grade shown on the plans by more than 1 in. in 10 ft. Variation must be regular and in one direction, and the final flow line must be in the direction shown on the plans.

Use a shield or cutting edge of steel plate around the head end of the pipe or box extending a short distance beyond the end if desired. The minimum distance for parallel pipe or box jacking or tunneling is 3 ft. or 2 times the diameter of the pipe or width of box, whichever is greater, unless otherwise shown on the plans.

3.2. **Boring or Tunneling.** Bore from a shaft in an approved location provided for the boring equipment and workmen.

Dispose of excavated material using an approved method. Use water or other appropriate drilling fluids in connection with the boring operation only as necessary to lubricate cuttings and pipe or box; do not use jetting.

Use a gel-forming colloidal drilling fluid consisting of high-grade, carefully processed bentonite to consolidate cuttings of the bit in unconsolidated soil formations. Seal the walls of the bore hole and furnish lubrication for subsequent removal of cuttings and immediate installation of the pipe.

Allowable variations from line and grade are specified in Section 476.3.1., "Jacking." Pressure-grout any over excavation of more than 1 in.

3.2.1. **Larger Diameter Boring Methods.** Use the pilot hole or auger method for drainage and large utility borings. Pressure-grout any over excavation of more than 1 in. Pressure-grout between the carrier pipe and casing when shown on the plans.

3.2.1.1. **Pilot Hole Method.** Bore a 2-in. pilot hole the entire length of the crossing, and check it for line and grade during the boring or tunneling operation on the opposite end of the bore from the work shaft. This pilot hole will serve as centerline for the larger diameter hole to be bored.

3.2.1.2. **Auger Method.** Use a steel encasement pipe of the appropriate diameter equipped with a cutter head to mechanically perform the excavation. Use augers of large enough diameter to convey the excavated material to the work shaft.

3.2.2. **Electrical and Communication Conduit Boring.** Limit over excavation to the dimensions shown in Table 1 for electrical and communication conduit borings. Increased boring diameters will be allowed for outer diameters of casing and couplings. Pressure-grouting will not be required for electrical and communication conduit borings.

Table 1
Allowable Bore Diameter for Electrical or Communication Conduit or Casing

Single Conduit Bores		Multiple Conduit Bores	
Conduit Size (in.)	Maximum Allowable Bore (in.)	Conduit Size (in.) ¹	Maximum Allowable Bore (in.)
2	4	4	6
3	6	5	8
4	6	6	10
6	10	7	12
		8	12

1. The diameter of multiple conduits is the sum of the outside diameter of the 2 largest conduits for placement of up to 4 conduits in one bore. Submit boring diameters for the Engineer's approval when more than 4 conduits are to be placed in a bore.

- 3.3. **Tunneling.** Use an approved tunneling method where the characteristics of the soil, the size of the proposed pipe, or the use of monolithic pipe would make the use of tunneling more satisfactory than jacking or boring, or when shown on the plans.

Ensure the lining of the tunnel is strong enough to support the overburden when tunneling is permitted. Submit the proposed liner method for approval. Approval does not relieve the Contractor of the responsibility for the adequacy of the liner method.

Pressure-grout the space between the liner plate and the limits of excavation.

Pressure-grout between the carrier pipe and liner plate when shown on the plans.

- 3.4. **Joints.** Make joints by field bolting or connecting bands, whichever is feasible if corrugated metal pipe is used. Make the joints in accordance with Item 464, "Reinforced Concrete Pipe," if reinforced concrete pipe is used. Make the joints in accordance with Item 462, "Concrete Box Culverts and Drains," if reinforced concrete box is used.

4. MEASUREMENT

This Item will be measured by the foot between the ends of the pipe or box along the flow line.

This is a plans quantity measurement Item. The quantity to be paid is the quantity shown in the proposal, unless modified by Article 9.2., "Plans Quantity Measurement." Additional measurements or calculations will be made if adjustments of quantities are required.

5. PAYMENT

The work performed and materials furnished in accordance with this Item and measured as provided under "Measurement" will be paid for at the unit price bid for "Jacking, Boring, or Tunneling Pipe" of the type, size, and class specified; or "Jacking, Boring, or Tunneling Pipe" of the type, size, and design specified; or "Jacking or Tunneling Box Culvert" of the size specified.

This price is full compensation for excavation, grouting, backfilling, and disposal of surplus material; furnishing pipe, box, and pipe liner materials required for tunnel operations; preparation, hauling, and installing of pipe, box, and pipe liner materials; and materials, tools, equipment, labor, and incidentals.

Protection methods for open excavations deeper than 5 ft. will be measured and paid for as required under Item 402, "Trench Excavation Protection," or Item 403, "Temporary Special Shoring."

Item 479

Adjusting Manholes and Inlets



1. DESCRIPTION

Adjust or cap existing manholes or inlets. Drainage junction boxes will be classified as manholes.

2. MATERIALS

Reuse removed manhole and inlet rings, plates, grates, and covers if they are in good condition as determined by the Engineer. Provide additional materials in accordance with Item 465, "Junction Boxes, Manholes, and Inlets," at no cost to the Department. Use single- or multiple-piece prefabricated metal, polymer, plastic, or rubber extension rings for the adjustment of manholes as approved. Limit the height of flexible extension rings to 3 in. Provide concrete that meets Item 421, "Hydraulic Cement Concrete."

Ensure frames and grates, or rings and covers, above grade are of single-piece cast iron manufactured in compliance with Item 471, "Frames, Grates, Rings, and Covers." Provide steel riser material compliant with ASTM A36. Provide steel adjustable risers that include a stainless steel adjustable stud with positive lock that adjusts the diameter $\pm 3/8$ in. Provide steel risers that include a minimum of 3 allen head set screws that lock the riser to the manhole or catch basin frame. Ensure seating surfaces are flat and true and provide a non-rocking seating surface.

3. CONSTRUCTION

Perform all work in accordance with Item 465, "Junction Boxes, Manholes, and Inlets." Excavate and backfill in accordance with Item 400, "Excavation and Backfill for Structures." Carefully remove manhole and inlet rings, covers, plates, and grates to be reused. Clean mortar and grease from the contact areas of all reused items. Dispose of unused removed material as directed. Use construction methods described in Section 479.3.1., "Lowering the Top of a Manhole or Inlet," and Section 479.3.2., "Raising the Top of a Manhole or Inlet," unless otherwise shown on the plans.

3.1. **Lowering the Top of a Manhole or Inlet.** Remove a sufficient depth of brick courses or concrete to permit reconstruction on a batter not exceeding 1 in. horizontal to 2 in. vertical. Clean the mortar from the top course of brick where brickwork is present. Rebuild the manhole or inlet to the original top dimensions or to the dimensions shown on the plans. Install the manhole or inlet ring and the cover, plate, or grate to conform to the proposed new surface contour.

3.2. **Raising the Top of a Manhole or Inlet.** Clean the top surface of brick or concrete. Construct to the proper new elevation using new rubber extension rings, concrete rings, or Class A concrete. Provide rubber manhole and catch basin risers of minimum 80% by weight recycled rubber and minimum 10% by volume recycled RFL coated fiber. Provide rubber manhole and catch basin adjustment risers that are of uniform quality, free from cracks, holes, and any other surface defects. Construction must be suitable for AASHTO H20 live loads. Load certifications for materials will be made available upon request. Install the manhole or inlet ring and the cover, plate, or grate to conform to the proposed new surface contour. Install prefabricated extension rings in accordance with manufacturer's instructions.

3.3. **Capping an Inlet or Manhole.** Remove the inlet or manhole to a minimum of 1 ft. below subgrade elevation or as indicated on the plans. Cap as shown on the plans.

4. MEASUREMENT

Adjusted or capped manholes or inlets will be measured as each manhole or inlet adjusted.

5. PAYMENT

The work performed and materials furnished in accordance with this Item and measured as provided under "Measurement" will be paid for at the unit price bid for "Adjusting Manholes," "Adjusting Inlets," or "Adjusting Manholes and Inlets." This price is full compensation for materials, including backfill as required, and for excavation, tools, equipment, labor, and incidentals.

Item 480

Cleaning Existing Culverts



1. DESCRIPTION

Remove all extraneous material from existing culvert barrels and pipes.

2. WORK METHODS

Expose all inside surfaces of the specified culverts. Do not move or damage the culvert. Dispose of material in accordance with federal, state, and local regulations. Place on roadway slopes when approved.

Perform cleaning to maintain drainage during construction. Acceptance of the cleaned culverts occurs at final acceptance of the project in accordance with Article 5.11., "Final Cleanup," unless otherwise shown on the plans.

3. MEASUREMENT

This Item will be measured by each complete culvert cleaned regardless of the number of barrels or pipes at each location or by the cubic yard. If measurement is by the cubic yard, the volume of material to be removed will be computed by the method of average end areas in its original position.

4. PAYMENT

The work performed in accordance with this Item and measured as provided under "Measurement" will be paid for at the unit price bid for "Cleaning Existing Culverts." This price is full compensation for excavation, disposal of excavated material, equipment, labor, tools, and incidentals.

Item 481

Pipe for Drains



1. DESCRIPTION

Furnish and install pipe for drains.

2. MATERIALS

Furnish polyvinyl chloride (PVC) pipe meeting the requirements of ASTM D1785, Schedule 40, and furnish PVC fittings meeting the requirements of ASTM D2466. PVC pipe and fittings meeting the requirements of ASTM D3034, Type SDR 35 may be used for installations encased in concrete or buried in soil.

Furnish a manufacturer's certification stating the material meets the appropriate ASTM specification.

Furnish pipe marked with:

- manufacturer's name or trademark and code;
- nominal size;
- PVC cell classification (example: 12454-B);
- schedule, size, or other legend (example: SDR-35 PVC Sewer Pipe); and
- specification designation (example: ASTM D1785).

Furnish fittings marked with:

- manufacturer's name or trademark;
- nominal size;
- material designation (example: PVC);
- schedule, size, or other legend (example: Schedule 40); and
- specification designation (example: ASTM D3034).

Furnish solvent meeting the requirements of ASTM D2564 for solvent-welding of fittings.

Provide other types of pipe and fittings as indicated.

Provide fittings, hangers, clamps, straps, anchors, and guard plates in accordance with the details shown on the plans.

3. CONSTRUCTION

Excavate and backfill for pipe installation in accordance with Item 400, "Excavation and Backfill for Structures." Install pipe as shown on the plans or as directed. Solvent-weld all fittings, including splice fittings, to provide a watertight fit. Do not splice straight sections of pipe at intervals shorter than 20 ft. unless at the end of a run or otherwise approved.

Degrease all exposed PVC pipe and fittings, and apply an acrylic water-based primer followed by a coating of the same color used for adjacent concrete surface unless otherwise shown on the plans.

Follow manufacturer's specifications for installation of other types of pipe (material other than PVC) when indicated.

4. MEASUREMENT

This Item will be measured by the foot along the centerline of the installed pipe of the nominal size shown on the plans.

5. PAYMENT

The work performed and materials furnished in accordance with this Item and measured as provided under "Measurement" will be paid for at the unit price bid for "Pipe" of the sizes and types specified. This price is full compensation for furnishing and installing the pipe and for fittings, hangers, clamps, straps, anchors, guard plates, painting, equipment, labor, tools, and incidentals. Excavation and backfill will not be paid for directly but will be considered subsidiary to this Item.

Item 483

Concrete Bridge Deck Surfacing



1. DESCRIPTION

Surface concrete bridge deck as specified to provide prepared substrate for concrete overlay or to remediate a finished surface.

2. EQUIPMENT

Use equipment within the maximum allowed legal load or provide analysis showing equipment will not overstress the bridge. Use machines equipped with dust controls measures and shielding to prevent flying debris from leaving the work area.

- 2.1. **Milling.** Use concrete milling equipment capable of maintaining constant depth of cut as specified. Equip machine with automated debris collection system.
- 2.2. **Hydro-Demolition.** Use equipment consisting of ultra-high pressure water jets (> 10,000 psi) capable of removing concrete to depth specified. Provide machine that can to be calibrated to remove an incremental depth of uniform strength concrete.
- 2.3. **Shot Blasting.** Use self-propelled shot blasting equipment utilizing steel abrasive being propelled at the concrete surface and equipped with a self-contained vacuum system to collect all removed debris.
- 2.4. **Diamond Grinding.** Use self-propelled diamond grinding equipment capable of removing concrete surface and producing corduroy type texture. Provide machine equipped with dual longitudinal controls capable of operating on both sides automatically from any longitudinal grade reference and have cutting wheel containing 50 to 60 diamond blades per foot. Minimize dust escaping into environment by equipping machine with self-contained vacuum system to collect all debris removed.
- 2.5. **Saw Grooving.** Use sawing equipment capable of cutting grooves in completed bridge slabs and top slabs of direct traffic culverts. Provide grooves that are 1/8 to 3/16 in. deep, nominally 1/8 in. wide, and spaced at 1 in. Use sawing equipment capable of cutting grooves in hardened concrete to within 18 in. of the barrier rail or curb.

3. CONSTRUCTION

Protect bridge joints, drains, and other appurtenances from surfacing operations. Following surfacing, clean the surface to remove all cuttings and debris. Dispose of all cuttings and debris properly.

Use chipping tools and other smaller approved concrete surfacing equipment in small areas not accessible to the large surfacing equipment.

Approval to begin work is not an endorsement of proposed equipment. If equipment fails to meet specification requirements, replacing equipment may be required. No additional time or compensation to adjust or replace equipment will be granted.

Perform concrete bridge deck surfacing as specified in accordance with the following listed methods:

- 3.1. **Milling.** Mill the existing deck to remove concrete to the depth specified. Provide a uniformly rough surface with a chipped appearance suitable for bonding a concrete overlay. Scarify at locations shown on the plans

or as directed to the depths shown on the plans. Measure the depth from the level of the existing surface to the high points on the scarified surface.

Ensure damage does not occur to the bridge slab reinforcing steel, armored joints, slab joints, drainage hardware, and other appurtenances. Stop milling operations if reinforcing steel is encountered. Proceed with further milling only when approved to do so.

Establish and maintain independent grade control for concrete scarifying operations when appropriate or required.

Use chipping tools to remove concrete in small areas not accessible to the mechanical scarifier.

- 3.2. **Hydro-Demolition.** Submit for approval water disposal plan associated with the work. Follow all water disposal requirements per federal, state, and local law. Temporarily plug all bridge drains near the area of work to prevent runoff as a result of the work from being released. Protect surrounding property and traffic from water spray and material dislodged.

Demonstrate hydro-demolition on test areas as designated to calibrate machine to obtain concrete removal depth and finish as specified and as approved. At a minimum, calibrate machine to remove all unsound concrete and sound concrete to the specified depth.

Remove additional concrete to obtain a minimum of 3/4 in. around the bars by hydro-demolition or other approved method if reinforcing steel is exposed.

Stop and recalibrate machine when depth of removal or surface roughness is different than approved.

- 3.3. **Shot Blasting.** Demonstrate shot blasting on test areas as designated to calibrate machine to obtain depth of surface removal required and to obtain finish as specified and as approved.

Do not alter grade or cross slope unless shown otherwise.

Maintain and adjust machine calibration to produce surfacing required.

- 3.4. **Diamond Grinding.** Demonstrate diamond grinding on designated area and obtain approval of finish produced.

Perform grinding in longitudinal direction. Grind surfaces on both sides of transverse joints to be flush (same elevation). Eliminate minor depressions by extra grinding as directed.

Produce a uniform surface with a longitudinal corduroy type texture that eliminates joint and crack faults. Maintain transverse cross slope to provide drainage across surface.

Repeat grinding until surface grade and cross slope satisfies ride requirements. Minimum ride requirements are 1/4 in. in 10 ft. unless shown otherwise.

Saw-cut transversely the ground areas to provide grooved surface in accordance with Section 483.3.5., "Sawing Grooving," unless otherwise directed.

- 3.5. **Sawing Grooving.** Cut grooves into concrete surface perpendicular to the structure centerline. Cut grooves across the slab to within 18 in. of the barrier rail, curb, or median divider. At skewed metal expansion joints in bridge slabs, adjust groove cutting by using narrow-width cutting heads so all grooves end within 6 in. of the joint, measured perpendicular to the centerline of the metal joint. Leave no ungrooved surface wider than 6 in. adjacent to either side of the joint. Ensure the minimum distance to the first groove, measured perpendicular to the edge of the concrete joint or from the junction between the concrete and the metal leg of the joint, is 1 in. Cut grooves continuously across construction joints or other joints in the concrete less than 1/2 in. wide. Apply the same procedure described above where barrier rails, curbs, or median dividers are

not parallel to the structure centerline to maintain the 18-in. maximum dimension from the end of the grooves to the gutter line. Cut grooves continuously across formed concrete joints.

4. MEASUREMENT

This Item will be measured by the square yard of concrete bridge deck surfaced.

5. PAYMENT

The work performed and equipment furnished in accordance with the Item and measured as provided under "Measurement" will be paid for at the unit price bid for "Milling Concrete Slab" to the depth required, "Hydro-Demolition" to the depth required, "Shot Blasting," "Diamond Grinding Slab," and "Saw Grooving." This price is full compensation for removing all material to the depths shown; preparing the surface; texturing the surface; saw grooving the surface; loading, hauling, unloading, and disposing of the cuttings; and equipment, labor, tools, and incidentals.

Item 490

Timber Structures



1. DESCRIPTION

Construct timber structures and timber portions of structures.

2. MATERIALS

Supply materials in accordance with details shown on the plans.

- 2.1. **Timber.** Supply timber in accordance with Item 491, "Timber for Structures."
- 2.2. **Hardware.** Galvanize all hardware including nails, except cast and malleable iron washers, in accordance with Item 445, "Galvanizing." Hardware may be cast or malleable iron or cut from steel plate as specified. Use bolts, pins, washers, and spikes of the size and type specified.

3. CONSTRUCTION

Construct structures in accordance with the plans. Complete all cutting and boring of timber before treatment if practical. Ensure all framing is true and exact. Drive nails and spikes to set the heads flush with the surface of the wood without making deep hammer marks in wood surfaces. Accurately cut all lumber and timber, and frame it so the joints have even bearing over the entire contact surface. Use washers under bolt heads and nuts. Countersink hardware when smooth or flush surfaces are required. Remove all bolt stock projecting beyond 1/4 in. from the top of the nut.

- 3.1. **Storage and Handling of Timber.** Store timber in piles at the worksite. Stack timber at least 12 in. above the ground surface. Arrange timber to shed water and allow air circulation to prevent warping. Protect it from weather. Clear the ground of weeds and rubbish underneath and near material piles. Handle timber without dropping, breaking outer fibers, or bruising. Use slings or other approved equipment. Provide corner protectors when using metal bands to bundle members.
- 3.2. **Stringers.** Size stringers to uniform depth at bearings, and place in position so knots near edges will be in the top portions of the stringers. Lay stringers with the crown up if practical. Stringers may have butt joints or lapped joints. Stagger the joints when stringers are 2 panels in length. Fasten all stringers securely by bolts or nails as shown on the plans.
- 3.3. **Bridging.** Frame cross-bridging or diaphragms between stringers neatly and accurately, and securely toenail with at least 2 nails in each end.
- 3.4. **Flooring.** Use glued laminated deck panels or single planks as shown on the plans. Place planks for single-plank floors with the heart side down. Provide 1/4-in. openings between planks for seasoned materials and tight joints for unseasoned or treated material. Spike each plank to each stringer or nailing strip firmly with spikes at least 3 in. longer than the thickness of the plank. Cut off the ends of the plank on a line parallel with the centerline of the roadway. Select the planks according to thickness, and lay them so no 2 adjacent planks vary in thickness by more than 1/8 in.
- 3.5. **Wheel Guards.** Lay wheel guards in sections at least 12 ft. long except where shorter sections are necessary to match end joints.
- 3.6. **Railings.** Stagger butt joints so adjacent rail joints do not occur on the same post. Bolt connections wherever possible.

- 3.7. **Holes for Bolts, Dowels, Rods, and Lag Screws.** Bore holes for round drift bolts and dowels with a bit 1/16 in. less in diameter than the bolt or dowel. Bore holes for square drift bolts or dowels equal to the least dimension of the bolt or dowel. Bore holes for machine bolts the same diameter as the bolt. Bore holes for rods 1/16 in. greater than the diameter of the rod. Bore holes for lag screws with a bit no larger than the root of the thread and 1/2 in. deeper than the penetration of the lag screws and equal to the diameter of the shank for the length of the shank.
- 3.8. **Field Treatment.** Treat cuts and drilled holes in treated piling or timbers and all abrasions after cutting and drilling as specified in Item 492, "Timber Preservative and Treatment."
- 3.9. **Painting.** Paint in accordance with details shown on the plans.

4. MEASUREMENT AND PAYMENT

The work performed, materials furnished, equipment, labor, tools, and incidentals will not be measured or paid for directly but will be subsidiary to bid items of the Contract.

Item 491

Timber for Structures



1. DESCRIPTION

Furnish and place lumber and timber.

2. MATERIALS

Furnish materials in accordance with details shown on the plans. Treat all lumber and timber in accordance with Item 492, "Timber Preservative and Treatment," unless otherwise shown on the plans. All material must bear the grade mark of an approved American Lumber Standards Committee agency. A grade mark must be on the timber before treating.

2.1. **Finish.** Provide material for railings, flooring, and wheel guards that is surfaced on 4 sides. Dress other timber as indicated on the plans.

2.2. **Timber and Lumber.** Use No. 1 Southern Pine or other materials required by the plans. Use the stress grade indicated on the plans. Timber grade designations refer to standard designations of the Southern Pine Inspection Bureau Standard Grading Rules. Use grading methods and general requirements that conform to the "General Requirements for Stress Grades" in ASTM D245.

2.3. **Structural Glued Laminated Timber.** Meet the grade, species, and other requirements outlined in ANSI/AITC A 190.1, "Structural Glued Laminated Timber." Bond all members with wet-use adhesive conforming to ASTM D2559. For individual laminations preservative treated before gluing, dry treated laminations to a moisture content of 16% or less and surface all lamination mating faces immediately before gluing.

Furnish glued laminated timber from a fabricator certified by AITC or who is a member of the APA Engineered Wood Systems (APA EWS) quality assurance program. AITC maintains a list of certified fabricators of structural glued laminated timber. The APA maintains a list of APA EWS trademarked glulam timber fabricators. Provide glued laminated timber marked with an AITC quality inspection mark or an APA EWS trademark as applicable.

3. EQUIPMENT

Use slings or other approved equipment for handling. Use equipment that will not damage the surface of the wood.

4. CONSTRUCTION

Construct timber structures in accordance with requirements of Item 490, "Timber Structures."

5. MEASUREMENT

Timber will be measured by the 1,000 board feet, computed on nominal sizes and the shortest commercial lengths practical for use.

6. PAYMENT

The work performed and materials furnished in accordance with this Item and measured as provided under "Measurement" will be paid for at the unit price bid for "Treated Timber" or "Untreated Timber." This price is full compensation for materials, hardware, equipment, tools, labor, painting, preservative treatment, and incidentals.

Timber used for erection purposes that is not part of the permanent structure will not be paid for directly but will be subsidiary to this Item. Timber piling will be paid for under Item 406, "Timber Piling."

Item 492

Timber Preservative and Treatment



1. DESCRIPTION

Pressure-treat piles, posts, timbers, and lumber with preservative.

2. MATERIALS

Treating plants furnishing treated timber products must meet the requirements of AWPA Standard M3, Part A. All treaters except those of structural glued laminated timber must be Department-approved. The Department's MPL has a list of approved treating plants. Treaters and suppliers of metal beam guard fence posts and blocks must enter into a stocking agreement with the Department. AWPA standards govern materials and methods of treatments including seasoning, preservatives, and inspection for treatment. Provide the level of preservative indicated in Table 1.

2.1. **Inspection.** Provide access for the inspector to all parts of facilities used in the conditioning and treating of timber products in accordance with Article 6.5., "Plant Inspection and Testing." The supplier must provide necessary assistance for the proper inspection of the materials being furnished.

2.2. **Identification.** Each piece or bundle of treated timber products must have a legible brand mark or tag indicating the name of the treater, date of treatment or lot number, and the AWPA treatment specification symbol. Furnish a completed Department "Certification of Compliance" Form 2148 with every shipment of treated timber products.

Table 1
Minimum Retention of Preservative

Product	Creosote (pcf)	Creosote–Coal Tar Solution (pcf)	PCP ¹ (pcf)	Copper Naphthenate (pcf)	ACZA ² or CCA ³ (pcf)	AWPA Use Category	AWPA Commodity Specification
AWPA Preservative Standard	P1/P13	P2	P8/P9	P8/P9	P5		
Timber piling for land or freshwater use, including foundation piles ⁴	12	12	0.6	0.10	0.8	UC4C	E
Timber piling for brackish or salt water use ⁴	25	25			2.5	UC5C	G
Round guard fence posts ⁵	10	10	0.5	0.069	0.5	UC4B	B
Rectangular guard fence posts ⁵	10	10	0.5	0.075	0.6	UC4B	A
Guard fence blocks ⁵	10	10	0.5	0.069	0.5	UC4B	B
Wire fence posts (round) ⁵	8	8	0.4	0.055	0.4	UC4A	B
Timber and lumber for land or freshwater use, or when subject to salt water splash ⁶	12	12	0.5	0.075	0.6	UC4C	A
Timber and lumber for use in brackish or salt water ⁷	25	25			2.5	UC5C	G
Structural glued laminated timber, laminations treated after gluing ⁷	12	12	0.6	0.060		UC4A	F
Structural glued laminated timber, laminations treated before gluing ⁸	10		0.6 (Type C)		0.4	UC4A	F

1. Pentachlorophenol Type A and Type C
2. Ammoniacal copper zinc arsenate.
3. Chromated copper arsenate Type C.
4. Retention determined by assay (0 to 3.0-in. zone except 0 to 2.0-in. zone for foundation piles in land and freshwater use).
5. Retention determined by assay (0 to 1.0-in. zone).
6. Retention determined by assay (0 to 0.6-in. zone for up to 2-in. thick material, and 0 to 1.0-in. zone for over 2-in. thick material).
7. Retention determined by assay (0 to 0.6-in. zone).
8. Retention determined by assay (0.5 to 1.0-in. zone).

- 2.3. **Field Treatment.** When it is necessary to bore holes or to cut pressure-treated materials after treatment or when any treated surface is badly scarred, treat the hole, cut, or scarred surface per AWPA Standard M4.

3. MEASUREMENT AND PAYMENT

The work performed, materials furnished, equipment, labor, tools, equipment, and incidentals will not be measured or paid for directly but will be subsidiary to pertinent Items.

Item 495

Raising Existing Structures



1. DESCRIPTION

Raise existing structures as shown on the plans.

2. MATERIALS

Furnish materials in accordance with the following.

- Item 420, "Concrete Substructures,"
- Item 421, "Hydraulic Cement Concrete,"
- Item 442, "Metal for Structures," and
- Item 434, "Bridge Bearings."

3. CONSTRUCTION

Submit detailed plans to raise structure. Approval of plans is required before beginning raising work. A licensed professional engineer must sign and seal the plans. Clearly indicate the methods, materials, cribbing, falsework or other supports, and equipment proposed. Repair or replace by an approved method any portions of the structure damaged by the raising operation. Approval of these plans does not relieve the Contractor from responsibility for the completion of the work nor from liability for repair or replacement of damaged portions of the structure due to the methods approved and employed.

- 3.1. **Preparation of Plans.** Apply vertical and horizontal loads such that the load capacities in bearing, shear, and flexure are not exceeded for any material or member carrying the load. Indicate jack positions and capacities and temporary hardware attachments on the plans.

Avoid jacking against the bottom of the slab. Use a jack with a minimum capacity of 2 times the unfactored dead load. Higher jacking capacity may be required if a single member is to be lifted individually in a multi-girder unit. Prohibit traffic on the structure until the structure is supported by cribbing, falsework, or the final supports.

Provide suitable cribbing, falsework, or other supports once the span or unit is resting on its final supports to prevent the various spans or units from dropping due to jack failure or other causes during the lifting operation.

- 3.2. **Temporary Support Load Factors.** Factor dead, live, and horizontal loads, including dynamic load allowance, per AASHTO LRFD *Bridge Design Specifications*. Design temporary supports to carry 2 times the dead load if traffic will not be allowed until permanent supports are in place.

It is not necessary to factor dead, live, and horizontal loads if design capacities of temporary supports include minimum safety factors of 2.0. Documentation on proprietary or project-specific temporary supports must include acceptable loads and safety factors.

- 3.3. **Raising of Spans.** Verify anchor bolts, closed joints, or other appurtenances do not restrict vertical movement before jacking. Jack spans from the existing bent cap or temporary falsework unless otherwise shown on the plans.

Loosen and remove all anchor bolt nuts or cut the anchor bolts to allow free vertical movement before raising. Replace all damaged or cut anchor bolts either by butt welding to existing bolts or by drilling into the

existing concrete cap a minimum of 12 in. and grouting in new bolts. Do not damage the bent cap reinforcing steel when installing new anchor bolts. Replace all damaged or lost anchor bolt nuts. Weld in accordance with Item 448, "Structural Field Welding."

Provide adequate guides or force to ensure vertical lifting and prevent drifting of the structure during the jacking operation. Immediately cease jacking operation if lifting causes damage to any portion of the structure. Provide pedestals as shown on the plans.

- 3.3.1. **Simple Spans with an Expansion Joint in the Deck at Every Bent.** Raise the span by jacking as shown on the plans. Raise all of the beams on one side of the bent simultaneously. Do not raise one end of a simple span more than 4 in. before raising the opposite end.
- 3.3.2. **Simple Beam Spans with a Continuous Deck Over the Bent.** Raise all beams on both sides of the bent simultaneously by jacking according to the plans. Do not raise one end of a span more than 2 in. before raising the opposite end of the span.
- 3.3.3. **Continuous Beams.** Raise the unit by jacking according to the approved plans. Raise all beams at a single bent simultaneously. The unit may be raised incrementally from bent to bent. Do not raise the unit more than 2 in. at any bent before raising it at the adjacent bents.

4. MEASUREMENT

This Item will be measured by the lump sum. Material for permanent steel pedestals will be measured in accordance with Item 442, "Metal for Structures," and material for permanent concrete pedestals will be measured in accordance with Item 420, "Concrete Substructures."

5. PAYMENT

The work performed and materials furnished in accordance with this Item and measured as provided under "Measurement" will be paid at the unit price bid for "Raising Existing Structure." This price is full compensation for shoring, falsework, jacking, fabric pads or elastomeric bearings, labor, tools, and equipment and for all materials except new pedestals. Pedestals will be paid for in accordance with Item 442, "Metal for Structures," or Item 420, "Concrete Substructures."

Item 496

Removing Structures



1. DESCRIPTION

Remove and either dispose of or salvage structures.

2. CONSTRUCTION

- 2.1. **Demolition Plans.** Follow the demolition sequence shown on the plans for bridge structures to be removed, or submit a demolition plan if indicated on the plans. Include in the required demolition plan the type and location of equipment to be used, the method and sequence of removal of the structural elements, and a narrative indicating the stability of the partially demolished structure is maintained throughout the demolition process. Have these plans signed and sealed by a licensed professional engineer when demolished structure intersects active roadways and as otherwise shown on the plans. Submit required demolition plans at least 14 days before starting work unless otherwise directed. Department approval of these plans is not required, but the Department reserves the right to request modifications to the plans when work could affect the safety of the traveling public and when around other transportation facilities to remain in place. Notify the Department 30 days before starting any bridge demolition work to allow for required notifications to other agencies.
- 2.2. **Removal.**
- 2.2.1. **Pipes.** Avoid damaging appurtenances determined by the Engineer to be salvageable.
- 2.2.2. **Concrete, Brick, or Stone Structures.** Portions of structures that will not interfere with the proposed construction may remain in place 2 ft. or more below the permanent ground line. Square off remaining structures and cut reinforcement flush with the surface of the concrete.
- 2.2.3. **Steel Structures.** Dismantle steel to be retained by the Department or re-erected by cold-cutting fastener heads and punching or drilling the remaining portion of the fastener, air-arc gouging welded connections, and flame-cutting beams along a straight line. The Engineer may approve other methods of cutting. Cut beams at the locations shown on the plans. Match-mark steel to be re-erected with paint in accordance with the erection drawings. Remove steel piles or cut off 2 ft. or more below the permanent ground line.
- 2.2.4. **Timber Structures.** Remove all fasteners from timber determined by the engineer to be salvageable. Remove timber piles or cut off 2 ft. or more below the permanent ground line.
- 2.3. **Salvage.** Avoid damage to materials shown on the plans to be salvaged. Deliver materials to be retained by the Department to the location shown on the plans. Block up salvaged steel materials off the ground.
- 2.4. **Disposal.** Material removed that is not deemed to be salvageable is the property of the Contractor. Dispose of removed material off the right of way in accordance with federal, state, and local regulations.
- 2.5. **Backfill.** Backfill excavation and voids to the original ground line if resulting from the removal of structures. Place backfill that will support any portion of the roadbed or embankment to the same requirements for placing embankment. Backfill other areas in 10 in. layers, loose measurement, and compact to the density of adjacent undisturbed material.

3. MEASUREMENT

This Item will be measured by each structure or by the foot.

4. PAYMENT

The work performed in accordance with this Item and measured as provided under "Measurement" will be paid for at the unit price bid for "Removing Structures" of the type of structure specified. This price is full compensation for demolition plan preparation, loading, hauling, disposal, stockpiling, removal of appurtenances, excavation and backfill, equipment, labor, tools, and incidentals.

Item 497

Sale of Salvageable Material



1. DESCRIPTION

Salvage and remove from existing structures the structural steel, steel railing, or any other material designated for sale to the Contractor. Materials to be salvaged will be shown on the plans.

2. CONSTRUCTION

Salvage material for sale to the limits indicated on the plans or as required by other specifications. Remove all materials designated for sale from the project site before final acceptance of the project.

3. MEASUREMENT

All salvaged structural steel, steel railing, or other material designated for sale to the Contractor will be measured as a lump sum unit.

4. PAYMENT

Salvaged material is a credit item to the Department and will be deducted from the Contractor's monthly construction estimate upon completion of the removal.

Item 499

Adjusting Steel Shoes



1. DESCRIPTION

Adjust and reset steel shoes as shown on the plans.

2. CONSTRUCTION

Remove the existing welds between the shoes and the girder flanges by arc-air gouging. Loosen or remove anchor bolt nuts as required to allow free vertical movement before raising. Jack the girders up to free the shoes and allow the pin between the top and bottom bolsters to rotate freely. Drive out the pin if it does not rotate freely, then clean and lubricate it before reinstalling. Reset the shoes relatively plumb for a temperature of 70°F. Lower the girders and reweld the shoes in this position. Use the same weld size as the original weld unless directed otherwise. Weld and grind smooth any excess gouges caused by weld removal. Grind any original weld metal not removed by arc-air gouging. Grind all exposed corners to a 1/16-in. radius.

Use jacks with a capacity adequate to raise the girders free of the shoes without exceeding a bearing pressure on the concrete cap of 1,500 psi. Use jacks with a capacity of at least 1.5 times the shoe design load or as indicated on the plans. Repair any concrete spalls caused by the Contractor's operations in accordance with Item 429, "Concrete Structure Repair."

Replace any shoes or parts of shoes as shown on the plans. Repair or replace anchor bolts, nuts, or other steel elements damaged during the shoe adjustment in accordance with Item 442, "Metal for Structures," and Item 448, "Structural Field Welding."

3. MEASUREMENT

This Item will be measured by each shoe adjusted.

4. PAYMENT

The work performed and materials furnished in accordance with this Item and measured as provided under "Measurement" will be paid for at the price bid for "Adjusting Steel Shoes." This price is full compensation for adjusting, resetting, and repairing steel shoes as shown on the plans. Price includes materials, jacking and other equipment, labor, tools, and incidentals. No additional payment will be made for repairs necessitated by the Contractor's operations or for members that the Contractor elects to replace rather than repair.

This page intentionally left blank

500 Items

Miscellaneous Construction

This page intentionally left blank

Item 500

Mobilization



1. DESCRIPTION

Establish and remove offices, plants, and facilities. Move personnel, equipment, and supplies to and from the project or the vicinity of the project site to begin work or complete work on Contract Items. Bonds and insurance are required for performing mobilization.

For Contracts with emergency mobilization, provide a person and method of contact available 24 hrs. a day, 7 days a week unless otherwise shown on the plans. The time of notice will be the transmission time of the written notice or notice provided orally by the Department's representative.

2. MEASUREMENT

This Item will be measured by the lump sum or each as the work progresses. Mobilization is calculated on the base bid only and will not be paid for separately on any additive alternate items added to the Contract.

3. PAYMENT

For this Item, the adjusted Contract amount will be calculated as the total Contract amount less the lump sum for mobilization. Except for Contracts with callout or emergency work, mobilization will be paid in partial payments as follows:

- Payment will be made upon presentation of a paid invoice for the payment or performance bonds and required insurance,
- Payment will be made upon verification of documented expenditures for plant and facility setup. The combined amount for all these facilities will be no more than 10% of the mobilization lump sum or 1% of the total Contract amount, whichever is less,
- When 1% of the adjusted Contract amount for construction Items is earned, 50% of the mobilization lump sum bid or 5% of the total Contract amount, whichever is less, will be paid. Previous payments under this Item will be deducted from this amount,
- When 5% of the adjusted Contract amount for construction Items is earned, 75% of the mobilization lump sum bid or 10% of the total Contract amount, whichever is less, will be paid. Previous payments under the Item will be deducted from this amount,
- When 10% of the adjusted Contract amount for construction Items is earned, 90% of the mobilization lump sum bid or 10% of the total Contract amount, whichever is less, will be paid. Previous payments under this Item will be deducted from this amount,
- Upon final acceptance, 97% of the mobilization lump sum bid will be paid. Previous payments under this Item will be deducted from this amount, and
- Payment for the remainder of the lump sum bid for "Mobilization" will be made after all submittals are received, final quantities have been determined and when any separate vegetative establishment and maintenance, test, and performance periods provided for in the Contract have been successfully completed.

For projects with extended maintenance or performance periods, payment for the remainder of the lump sum bid for "Mobilization" will be made 6 months after final acceptance.

For Contracts with callout or emergency work, "Mobilization," will be paid as follows:

- Payment will be made upon presentation of a paid invoice for the payment of performance bonds and required insurance,
- Mobilization for callout work will be paid for each callout work request, and
- Mobilization for emergency work will be paid for each emergency work request.

Item 502

Barricades, Signs, and Traffic Handling



1. DESCRIPTION

Provide, install, move, replace, maintain, clean, and remove all traffic control devices shown on the plans and as directed.

2. CONSTRUCTION

Comply with the requirements of Article 7.2., "Safety."

Implement the traffic control plan (TCP) shown on the plans.

Install traffic control devices straight and plumb. Make changes to the TCP only as approved. Minor adjustments to meet field conditions are allowed.

Submit Contractor-proposed TCP changes, signed and sealed by a licensed professional engineer, for approval. The Engineer may develop, sign, and seal Contractor-proposed changes. Changes must conform to guidelines established in the TMUTCD using approved products from the Department's Compliant Work Zone Traffic Control Device List.

Maintain traffic control devices by taking corrective action when notified. Corrective actions include, but are not limited to, cleaning, replacing, straightening, covering, and removing devices. Maintain the devices such that they are properly positioned and spaced, legible, and have retroreflective characteristics that meet requirements day or night and in all weather conditions.

The Engineer may authorize or direct in writing the removal or relocation of project limit advance warning signs. When project limit advance warning signs are removed before final acceptance, provide traffic control in accordance with the TMUTCD for minor operations as approved.

Remove all traffic control devices upon completion of the work as shown on the plans or as directed.

3. MEASUREMENT

Barricades, Signs, and Traffic Handling will be measured by the month. Law enforcement personnel with patrol vehicles will be measured by the hour for each person.

4. PAYMENT

- 4.1. **Barricades, Signs, and Traffic Handling.** Except for Contracts with callout work and work orders, the work performed and materials furnished in accordance with this Item and measured as provided under "Measurement" will be paid for at the unit price bid for "Barricades, Signs, and Traffic Handling." This price is full compensation for installation, maintenance, adjustments, replacements, removal, materials, equipment, labor, tools, and incidentals.

The work performed and materials furnished in accordance with this Item and measured as provided under "Measurement" will be paid for at the unit price bid for "Barricades, Signs, and Traffic Handling." This price is full compensation for installation, maintenance, adjustments, replacements, removal, materials, equipment, labor, tools, and incidentals.

When the plans establish pay items for particular work in the TCP, that work will be measured and paid under pertinent Items.

- 4.1.1. **Initiation of Payment.** Payment for this Item will begin on the first estimate after barricades, signs, and traffic handling devices have been installed in accordance with the TCP and construction has begun.
- 4.1.2. **Paid Months.** Monthly payment will be made each succeeding month for this Item provided the barricades, signs, and traffic handling devices have been installed and maintained in accordance with the TCP until the Contract amount has been paid.
- If, within the time frame established by the Engineer, the Contractor fails to provide or properly maintain signs and barricades in compliance with the Contract requirements, as determined by the Engineer, the Contractor will be considered in noncompliance with this Item. No payment will be made for the months in question, and the total final payment quantity will be reduced by the number of months the Contractor was in noncompliance.
- 4.1.3. **Maximum Total Payment Before Acceptance.** The total payment for this Item will not exceed 10% of the total Contract amount before final acceptance in accordance with Article 5.12., "Final Acceptance." The remaining balance will be paid in accordance with Section 502.4.1.5., "Balance Due."
- 4.1.4. **Total Payment Quantity.** The quantity paid under this Item will not exceed the total quantity shown on the plans except as modified by change order and as adjusted by Section 502.4.1.2., "Paid Months." An overrun of the plans quantity for this Item will not be allowed for approving designs; testing; material shortages; closed construction seasons; curing periods; establishment, performance, test, and maintenance periods; failure to complete the work in the number of months allotted; nor delays caused directly or indirectly by requirements of the Contract.
- 4.1.5. **Balance Due.** The remaining unpaid months of barricades less non-compliance months will be paid on final acceptance of the project, if all work is complete and accepted in accordance with Article 5.12., "Final Acceptance."
- 4.1.6. **Contracts with Callout Work and Work Orders.** The work performed and the materials furnished with this Item and measured as provided under "Measurement," will be considered subsidiary to pertinent Items, except for federally funded Contracts.
- 4.2. **Law Enforcement Personnel.** The work performed and materials furnished in accordance with this Item and measured as provided under "Measurement," will be paid by Contractor force account for "Law Enforcement Personnel." This price is full compensation for furnishing all labor, materials, supplies, equipment, patrol vehicle, fees, and incidentals necessary to complete the work as directed.

Item 504

Field Office and Laboratory



1. DESCRIPTION

Provide field offices and laboratories for exclusive use of the Engineer and inspection staff.

2. EQUIPMENT

2.1. **General.** Furnish facilities after receipt of the work order and before beginning physical work on the project. Provide field offices of the type and number specified near the worksite at an acceptable location. If desired, use permanent buildings or rental space meeting the requirements for field offices instead of portable buildings only if approved. Maintain the field office until the Department accepts the project. Furnish other equipment as required.

Provide inspection laboratories of the type specified before beginning the fabrication of products required by the Contract. Locate the building so that plant operations are visible from the building. Maintain the laboratories until the production of the associated product is complete.

Immediately repair or replace facilities if damaged in any manner. Payment for repair will not be made unless it is the result of negligence by the Department. Reimburse the Department for equipment damaged by the Contractor's operations. Remove buildings and other facilities and restore the right of way before project acceptance when facilities are allowed in the right of way.

2.1.1. **Parking and Fencing.** Provide an all-weather parking area for the sole use of at least 2 State-owned vehicles unless otherwise shown on the plans. Situate the area near the field office or laboratory at an acceptable location. Maintain the parking area until the project is completed and restore the area to a condition acceptable to the Engineer upon project completion.

Enclose the field office or laboratory and the parking area with a 6-ft. chain-link fence, a top-mounted 3-strand barbed wire, and a 12-ft. gate when shown on the plans.

2.1.2. **Buildings.**

2.1.2.1. **Field Office.** Provide field offices with roof, floor, doors, and screened windows. Ensure the floor is strong enough to support testing equipment and has an impervious floor covering. Ensure that the field office is tied down, weatherproof, piped for water and fuel, and electrically wired by personnel meeting the requirements of Article 7.18., "Electrical Requirements."

Furnish and install adequate equipment, outlets, lighting, air-conditioning, heating, and ventilation. Provide a partitioned restroom furnished with restroom supplies, a lavatory, and a flush toilet connected to a sewer or septic tank. If desired, furnish a portable toilet only when approved.

Provide secured and controlled access to the field office or laboratory through security measures such as bars, alarms, or security fencing. Furnish steps to the structures if directed.

2.1.2.2. **Laboratory.** Provide laboratories with all of the requirements described in Section 504.2.1.2.1., "Field Office." In addition, provide the following items unless otherwise directed:

- a 10 lb. ABC fire extinguisher with up-to-date inspection tag and a working smoke detector;
- laboratory equipment necessary for testing when shown on the plans;
- water (for testing purposes) from an approved source;

- an exhaust fan for concrete curing, asphalt, or other operations to meet Department and OSHA requirements (Vent all exhaust to the outside of the structure.);
- a work platform at least 18 in. long and 12 in. wide, mounted on a lumber post at least 6 × 6 in. extending through the floor and firmly fixed in the ground (The work platform support can be provided by other methods as shown on the plans or as directed.);
- a minimum of 20 ft. of total work counter length at least 3 ft. wide and 3 ft. above the floor and strong enough to support required testing equipment; and
- a laboratory sink measuring 24 × 30 in. and 12 in. deep.

- 2.1.3. **Field Office and Laboratory Appurtenances.** Provide workbenches and tables at least 3 ft. wide and 6 ft. long, chairs, and filing cabinets in an approved quantity. Provide solar screens, blinds, or shades if directed. Provide approved potable water, electricity, collection and disposal of trash, and janitorial services.

Provide internet connectivity, a printer/fax/scan/copier, and telephone if shown on the plans.

Provide a closet within the facility for Contracts that require a nuclear gauge for moisture or density determination, or a separate structure for storage of the gauge located as far as possible from normal office work. Provide internal keyed deadbolt locks and hinges with pins on the inside of the storage area for all doors allowing access to the nuclear gauge.

2.2. **Structure Types.**

- 2.2.1. **Type A Structure (Field Laboratory).** Provide at least 200 sq. ft. of gross floor area in rooms 8 ft. high. Partition the building into at least 2 rooms, each furnished with an exterior door and at least 2 windows.
- 2.2.2. **Type B Structure (Field Office and Laboratory).** Provide at least 600 sq. ft. of gross floor area in rooms 8 ft. high. Partition the floor area into at least 3 interconnected rooms with doors, 2 exterior doors, and at least 2 windows in each room.
- 2.2.3. **Type C Structure (Field Office).** Provide at least 400 sq. ft. of gross floor area in rooms 8 ft. high. Partition the floor area into at least 2 interconnected rooms with doors, 2 exterior doors, and at least 2 windows in each room.
- 2.2.4. **Type D Structure (Asphalt Mix Control Laboratory).** Provide at least 700 sq. ft. of gross floor area in rooms 8 ft. high. Partition the floor area into at least 2 interconnected rooms with doors, 2 exterior doors, and at least 2 windows in each room.
- 2.2.4.1. **Asphalt Content by Ignition Method.** Provide enough power ventilation for the room, a NEMA 6-50R (208/240 V, 50 A) outlet within 3 ft. of the ignition oven location, and an independent exhaust outlet no farther than 8 ft. from the oven when asphalt content is determined by the ignition method. Provide a surface for the ignition oven that is level, sturdy, and fireproof with at least 6 in. of clearance between the furnace and other vertical surfaces.
- Vent the ignition oven to the outside.
- 2.2.5. **Type E Structure.** Provide building as shown on the plans.

3. **MEASUREMENT AND PAYMENT**

The work performed, materials furnished, utilities and utility service (including phone if required), appurtenances (including office equipment and Internet service), testing equipment, labor, tools, and incidentals will not be measured or paid for directly but will be subsidiary to pertinent items.

Item 506

Temporary Erosion, Sedimentation, and Environmental Controls



1. DESCRIPTION

Install, maintain, and remove erosion, sedimentation, and environmental control measures to prevent or reduce the discharge of pollutants in accordance with the Storm Water Pollution Prevention Plan (SWP3) on the plans and the Texas Pollutant Discharge Elimination System (TPDES) General Permit TXR150000. Control measures are defined as Best Management Practices used to prevent or reduce the discharge of pollutants. Control measures include, but are not limited to, rock filter dams, temporary pipe slope drains, temporary paved flumes, construction exits, earthwork for erosion control, pipe, construction perimeter fence, sandbags, temporary sediment control fence, biodegradable erosion control logs, vertical tracking, temporary or permanent seeding, and other measures. Erosion and sediment control devices must be selected from the *Erosion Control Approved Products* or *Sediment Control Approved Products* lists. Perform work in a manner to prevent degradation of receiving waters, facilitate project construction, and comply with applicable federal, state, and local regulations. Ensure the installation and maintenance of control measures is performed in accordance with the manufacturer's or designer's specifications.

Provide the Contractor Certification of Compliance before performing SWP3 or soil disturbing activities. By signing the Contractor Certification of Compliance, the Contractor certifies they have read and understand the requirements applicable to this project pertaining to the SWP3, the plans, and the TPDES General Permit TXR150000. The Contractor is responsible for any penalties associated with non-performance of installation or maintenance activities required for compliance. Ensure the most current version of the certificate is executed for this project.

2. MATERIALS

Furnish materials in accordance with the following:

- Item 161, "Compost,"
- Item 432, "Riprap," and
- Item 556, "Pipe Underdrains."

2.1. Rock Filter Dams.

2.1.1. **Aggregate.** Furnish aggregate with approved hardness, durability, cleanliness, and resistance to crumbling, flaking, and eroding. Provide the following:

- Types 1, 2, and 4 Rock Filter Dams. Use 3 to 6 in. aggregate.
- Type 3 Rock Filter Dams. Use 4 to 8 in. aggregate.

2.1.2. **Wire.** Provide minimum 20 gauge galvanized wire for the steel wire mesh and tie wires for Types 2 and 3 rock filter dams. Type 4 dams require:

- a double-twisted, hexagonal weave with a nominal mesh opening of 2-1/2 × 3-1/4 in.;
- minimum 0.0866 in. steel wire for netting;
- minimum 0.1063 in. steel wire for selvages and corners; and
- minimum 0.0866 in. for binding or tie wire.

2.1.3. **Sandbag Material.** Furnish sandbags meeting Section 506.2.8., "Sandbags," except that any gradation of aggregate may be used to fill the sandbags.

- 2.2. **Temporary Pipe Slope Drains.** Provide corrugated metal pipe, polyvinyl chloride (PVC) pipe, flexible tubing, watertight connection bands, grommet materials, prefabricated fittings, and flared entrance sections that conform to the plans. Recycled and other materials meeting these requirements are allowed if approved.
- Furnish concrete in accordance with Item 432, "Riprap."
- 2.3. **Temporary Paved Flumes.** Furnish asphalt concrete, hydraulic cement concrete, or other comparable non-erodible material that conforms to the plans. Provide rock or rubble with a minimum diameter of 6 in. and a maximum volume of 1/2 cu. ft. for the construction of energy dissipaters.
- 2.4. **Construction Exits.** Provide materials that meet the details shown on the plans and this Section.
- 2.4.1. **Rock Construction Exit.** Provide crushed aggregate for long- and short-term construction exits. Furnish aggregates that are clean, hard, durable, and free from adherent coatings such as salt, alkali, dirt, clay, loam, shale, soft or flaky materials, and organic and injurious matter. Use 4- to 8-in. aggregate for Type 1. Use 2- to 4-in. aggregate for Type 3.
- 2.4.2. **Timber Construction Exit.** Furnish No. 2 quality or better railroad ties and timbers for long-term construction exits, free of large and loose knots and treated to control rot. Fasten timbers with nuts and bolts or lag bolts, of at least 1/2 in. diameter, unless otherwise shown on the plans or allowed. Provide plywood or pressed wafer board at least 1/2 in. thick for short-term exits.
- 2.4.3. **Foundation Course.** Provide a foundation course consisting of flexible base, bituminous concrete, hydraulic cement concrete, or other materials as shown on the plans or directed.
- 2.5. **Embankment for Erosion Control.** Provide rock, loam, clay, topsoil, or other earth materials that will form a stable embankment to meet the intended use.
- 2.6. **Pipe.** Provide pipe outlet material in accordance with Item 556, "Pipe Underdrains," and details shown on the plans.
- 2.7. **Construction Perimeter Fence.**
- 2.7.1. **Posts.** Provide essentially straight wood or steel posts that are at least 60 in. long. Furnish soft wood posts with a minimum diameter of 3 in., or use nominal 2 × 4 in. boards. Furnish hardwood posts with a minimum cross-section of 1-1/2 × 1-1/5 in. Furnish T- or L-shaped steel posts with a minimum weight of 1.25 lb. per foot.
- 2.7.2. **Fence.** Provide orange construction fencing as approved.
- 2.7.3. **Fence Wire.** Provide 14 gauge or larger galvanized smooth or twisted wire. Provide 16 gauge or larger tie wire.
- 2.7.4. **Flagging.** Provide brightly-colored flagging that is fade-resistant and at least 3/4 in. wide to provide maximum visibility both day and night.
- 2.7.5. **Staples.** Provide staples with a crown at least 1/2 in. wide and legs at least 1/2 in. long.
- 2.7.6. **Used Materials.** Previously used materials meeting the applicable requirements may be used if approved.
- 2.8. **Sandbags.** Provide sandbag material of polypropylene, polyethylene, or polyamide woven fabric with a minimum unit weight of 4 oz. per square yard, a Mullen burst-strength exceeding 300 psi, and an ultraviolet stability exceeding 70%.

Use natural coarse sand or manufactured sand meeting the gradation given in Table 1 to fill sandbags. Filled sandbags must be 24 to 30 in. long, 16 to 18 in. wide, and 6 to 8 in. thick.

Table 1
Sand Gradation

Sieve Size	Retained (% by Weight)
#4	Maximum 3%
#100	Minimum 80%
#200	Minimum 95%

Aggregate may be used instead of sand for situations where sandbags are not adjacent to traffic. The aggregate size must not exceed 3/8 in.

- 2.9. **Temporary Sediment Control Fence.** Provide a net-reinforced fence using woven geo-textile fabric. Logos visible to the traveling public will not be allowed.
- 2.9.1. **Fabric.** Provide fabric materials in accordance with DMS-6230, "Temporary Sediment Control Fence Fabric."
- 2.9.2. **Posts.** Provide essentially straight wood or steel posts with a minimum length of 48 in., unless otherwise shown on the plans. Furnish soft wood posts at least 3 in. in diameter, or use nominal 2 × 4 in. boards. Furnish hardwood posts with a minimum cross-section of 1-1/2 × 1-1/2 in. Furnish T- or L-shaped steel posts with a minimum weight of 1.25 lb. per foot.
- 2.9.3. **Net Reinforcement.** Provide net reinforcement of at least 12.5 gauge (SWG) galvanized welded wire mesh, with a maximum opening size of 2 × 4 in., at least 24 in. wide, unless otherwise shown on the plans.
- 2.9.4. **Staples.** Provide staples with a crown at least 3/4 in. wide and legs 1/2 in. long.
- 2.9.5. **Used Materials.** Use recycled material meeting the applicable requirements if approved.
- 2.10. **Biodegradable Erosion Control Logs.**
- 2.10.1. **Core Material.** Furnish core material that is biodegradable or recyclable. Use compost, mulch, aspen excelsior wood fibers, chipped site vegetation, agricultural rice or wheat straw, coconut fiber, 100% recyclable fibers, or any other acceptable material unless specifically called out on the plans. Permit no more than 5% of the material to escape from the containment mesh. Furnish compost meeting the requirements of Item 161, "Compost."
- 2.10.2. **Containment Mesh.** Furnish containment mesh that is 100% biodegradable, photodegradable, or recyclable such as burlap, twine, UV photodegradable plastic, polyester, or any other acceptable material.
- Furnish biodegradable or photodegradable containment mesh when log will remain in place as part of a vegetative system.
- Furnish recyclable containment mesh for temporary installations.
- 2.10.3. **Size.** Furnish biodegradable erosion control logs with diameters shown on the plans or as directed. Stuff containment mesh densely so logs do not deform.

3. QUALIFICATIONS, TRAINING, AND EMPLOYEE REQUIREMENTS

- 3.1. **Contractor Responsible Person Environmental (CRPE) Qualifications and Responsibilities.** Provide and designate in writing at the preconstruction conference a CRPE and alternate CRPE who have overall responsibility for the storm water management program. The CRPE will implement storm water and erosion control practices; will oversee and observe storm water control measure monitoring and management; will monitor the project site daily and produce daily monitoring reports as long as there are BMPs in place or soil disturbing activities are evident to ensure compliance with the SWP3 and TPDES General Permit TXR150000. During time suspensions when work is not occurring or on contract non-work days, daily inspections are not required unless a rain event has occurred. The CRPE will provide recommendations on

how to improve the effectiveness of control measures. Attend the Department's preconstruction conference for the project. Ensure training is completed as identified in Section 506.3.3., "Training," by all applicable personnel before employees work on the project. Document and submit a list, signed by the CRPE, of all applicable Contractor and subcontractor employees who have completed the training. Include the employee's name, the training course name, and date the employee completed the training. Provide the most current list at the preconstruction conference or before SWP3 or soil disturbing activities. Update the list as needed and provide the updated list when updated.

- 3.2. **Contractor Superintendent Qualifications and Responsibilities.** Provide a superintendent that is competent, has experience with and knowledge of storm water management, and is knowledgeable of the requirements and the conditions of the TPDES General Permit TXR150000. The superintendent will manage and oversee the day to day operations and activities at the project site; work with the CRPE to provide effective storm water management at the project site; represent and act on behalf of the Contractor; and attend the Department's preconstruction conference for the project.
- 3.3. **Training.** All Contractor and subcontractor employees involved in soil disturbing activities, small or large structures, storm water control measures, and seeding activities must complete training as prescribed by the Department.

4. CONSTRUCTION

- 4.1. **Contractor Responsibilities.** Implement the SWP3 for the project site in accordance with the plans and specifications, TPDES General Permit TXR150000, and as directed. Coordinate storm water management with all other work on the project. Develop and implement an SWP3 for project-specific material supply plants within and outside of the Department's right of way in accordance with the specific or general storm water permit requirements. Prevent water pollution from storm water associated with construction activity from entering any surface water or private property on or adjacent to the project site.
- 4.2. **Implementation.** The CRPE, or alternate CRPE, must be accessible by phone and able to respond to project-related storm water management or other environmental emergencies 24 hr. per day.
- 4.2.1. **Commencement.** Implement the SWP3 as shown and as directed. Contractor-proposed recommendations for changes will be allowed as approved. Conform to the established guidelines in the TPDES General Permit TXR150000 to make changes. Do not implement changes until approval has been received and changes have been incorporated into the plans. Minor adjustments to meet field conditions are allowed and will be recorded in the SWP3.
- 4.2.2. **Phasing.** Implement control measures before the commencement of activities that result in soil disturbance. Phase and minimize the soil disturbance to the areas shown on the plans. Coordinate temporary control measures with permanent control measures and all other work activities on the project to assure economical, effective, safe, and continuous water pollution prevention. Provide control measures that are appropriate to the construction means, methods, and sequencing allowed by the Contract. Exercise precaution throughout the life of the project to prevent pollution of ground waters and surface waters. Schedule and perform clearing and grubbing operations so that stabilization measures will follow immediately thereafter if project conditions permit. Bring all grading sections to final grade as soon as possible and implement temporary and permanent control measures at the earliest time possible. Implement temporary control measures when required by the TPDES General Permit TXR150000 or otherwise necessitated by project conditions.
- Do not prolong final grading and shaping. Preserve vegetation where possible throughout the project, and minimize clearing, grubbing, and excavation within stream banks, bed, and approach sections.
- 4.3. **General.**
- 4.3.1. **Temporary Alterations or Control Measure Removal.** Altering or removal of control measures is allowed when control measures are restored within the same working day.

- 4.3.2. **Stabilization.** Initiate stabilization for disturbed areas no more than 14 days after the construction activities in that portion of the site have temporarily or permanently ceased. Establish a uniform vegetative cover or use another stabilization practice in accordance with the TPDES General Permit TXR150000.
- 4.3.3. **Finished Work.** Remove and dispose of all temporary control measures upon acceptance of vegetative cover or other stabilization practice unless otherwise directed. Complete soil disturbing activities and establish a uniform perennial vegetative cover. A project will not be considered for acceptance until a vegetative cover of 70% density of existing adjacent undisturbed areas is obtained or equivalent permanent stabilization is obtained in accordance with the TPDES General Permit TXR150000. An exception will be allowed in arid areas as defined in the TPDES General Permit TXR150000.
- 4.3.4. **Restricted Activities and Required Precautions.** Do not discharge onto the ground or surface waters any pollutants such as chemicals, raw sewage, fuels, lubricants, coolants, hydraulic fluids, bitumens, or any other petroleum product. Operate and maintain equipment on-site to prevent actual or potential water pollution. Manage, control, and dispose of litter on-site such that no adverse impacts to water quality occur. Prevent dust from creating a potential or actual unsafe condition, public nuisance, or condition endangering the value, utility, or appearance of any property. Wash out concrete trucks only as described in the TPDES General Permit TXR150000. Use appropriate controls to minimize the offsite transport of suspended sediments and other pollutants if it is necessary to pump or channel standing water (i.e., dewatering). Prevent discharges that would contribute to a violation of Edwards Aquifer Rules, water quality standards, the impairment of a listed water body, or other state or federal law.
- 4.4. **Installation, Maintenance, and Removal Work.** Perform work in accordance with the SWP3, according to manufacturers' guidelines, and in accordance with the TPDES General Permit TXR150000. Install and maintain the integrity of temporary erosion and sedimentation control devices to accumulate silt and debris until soil disturbing activities are completed and permanent erosion control features are in place or the disturbed area has been adequately stabilized as approved.

The Department will inspect and document the condition of the control measures at the frequency shown on the plans and will provide the Construction SWP3 Field Inspection and Maintenance Reports to the Contractor. Make corrections as soon as possible before the next anticipated rain event or within 7 calendar days after being able to enter the worksite for each control measure. The only acceptable reason for not accomplishing the corrections with the time frame specified is when site conditions are "Too Wet to Work." Take immediate action if a correction is deemed critical as directed. When corrections are not made within the established time frame, all work will cease on the project and time charges will continue while the control measures are brought into compliance. Commence work once the Engineer reviews and documents the project is in compliance. Commencing work does not release the Contractor of the liability for noncompliance of the SWP3, plans, or TPDES General Permit TXR150000.

The Engineer may limit the disturbed area if the Contractor cannot control soil erosion and sedimentation resulting from the Contractor's operations. Implement additional controls as directed.

Remove devices upon approval or as directed. Finish-grade and dress the area upon removal. Stabilize disturbed areas in accordance with the permit, and as shown on the plans or directed. Materials removed are considered consumed by the project. Retain ownership of stockpiled material and remove it from the project when new installations or replacements are no longer required.

- 4.4.1. **Rock Filter Dams for Erosion Control.** Remove trees, brush, stumps, and other objectionable material that may interfere with the construction of rock filter dams. Place sandbags as a foundation when required or at the Contractor's option.

Place the aggregate to the lines, height, and slopes specified, without undue voids for Types 1, 2, 3, and 5. Place the aggregate on the mesh and then fold the mesh at the upstream side over the aggregate and secure it to itself on the downstream side with wire ties, or hog rings for Types 2 and 3, or as directed. Place rock filter dams perpendicular to the flow of the stream or channel unless otherwise directed. Construct filter dams according to the following criteria unless otherwise shown on the plans:

- 4.4.1.1. **Type 1 (Non-Reinforced).**
- **Height.** At least 18 in. measured vertically from existing ground to top of filter dam.
 - **Top Width.** At least 2 ft.
 - **Slopes.** No steeper than 2:1.
- 4.4.1.2. **Type 2 (Reinforced).**
- **Height.** At least 18 in. measured vertically from existing ground to top of filter dam.
 - **Top Width.** At least 2 ft.
 - **Slopes.** No steeper than 2:1.
- 4.4.1.3. **Type 3 (Reinforced).**
- **Height.** At least 36 in. measured vertically from existing ground to top of filter dam.
 - **Top Width.** At least 2 ft.
 - **Slopes.** No steeper than 2:1.
- 4.4.1.4. **Type 4 (Sack Gabions).** Unfold sack gabions and smooth out kinks and bends. Connect the sides by lacing in a single loop–double loop pattern on 4- to 5-in. spacing for vertical filling. Pull the end lacing rod at one end until tight, wrap around the end, and twist 4 times. Fill with stone at the filling end, pull the rod tight, cut the wire with approximately 6 in. remaining, and twist wires 4 times.
- Place the sack flat in a filling trough, fill with stone, connect sides, and secure ends as described above for horizontal filling.
- Lift and place without damaging the gabion. Shape sack gabions to existing contours.
- 4.4.1.5. **Type 5.** Provide rock filter dams as shown on the plans.
- 4.4.2. **Temporary Pipe Slope Drains.** Install pipe with a slope as shown on the plans or as directed. Construct embankment for the drainage system in 8-in. lifts to the required elevations. Hand-tamp the soil around and under the entrance section to the top of the embankment as shown on the plans or as directed. Form the top of the embankment or earth dike over the pipe slope drain at least 1 ft. higher than the top of the inlet pipe at all points. Secure the pipe with hold-downs or hold-down grommets spaced a maximum of 10 ft. on center. Construct the energy dissipaters or sediment traps as shown on the plans or as directed. Construct the sediment trap using concrete or rubble riprap in accordance with Item 432, "Riprap," when designated on the plans.
- 4.4.3. **Temporary Paved Flumes.** Construct paved flumes as shown on the plans or as directed. Provide excavation and embankment (including compaction of the subgrade) of material to the dimensions shown on the plans unless otherwise indicated. Install a rock or rubble riprap energy dissipater, constructed from the materials specified above, to a minimum depth of 9 in. at the flume outlet to the limits shown on the plans or as directed.
- 4.4.4. **Construction Exits.** Prevent traffic from crossing or exiting the construction site or moving directly onto a public roadway, alley, sidewalk, parking area, or other right of way areas other than at the location of construction exits when tracking conditions exist. Construct exits for either long- or short-term use.
- 4.4.4.1. **Long-Term.** Place the exit over a foundation course as required. Grade the foundation course or compacted subgrade to direct runoff from the construction exits to a sediment trap as shown on the plans or as directed. Construct exits with a width of at least 14 ft. for one-way and 20 ft. for two-way traffic for the full width of the exit, or as directed.
- 4.4.4.1.1. **Type 1.** Construct to a depth of at least 8 in. using crushed aggregate as shown on the plans or as directed.
- 4.4.4.1.2. **Type 2.** Construct using railroad ties and timbers as shown on the plans or as directed.

- 4.4.4.2. **Short-Term.**
- 4.4.4.2.1. **Type 3.** Construct using crushed aggregate, plywood, or wafer board. This type of exit may be used for daily operations where long-term exits are not practical.
- 4.4.4.2.2. **Type 4.** Construct as shown on the plans or as directed.
- 4.4.5. **Earthwork for Erosion Control.** Perform excavation and embankment operations to minimize erosion and to remove collected sediments from other erosion control devices.
- 4.4.5.1. **Excavation and Embankment for Erosion Control Features.** Place earth dikes, swales, or combinations of both along the low crown of daily lift placement, or as directed, to prevent runoff spillover. Place swales and dikes at other locations as shown on the plans or as directed to prevent runoff spillover or to divert runoff. Construct cuts with the low end blocked with undisturbed earth to prevent erosion of hillsides. Construct sediment traps at drainage structures in conjunction with other erosion control measures as shown on the plans or as directed.
- Create a sediment basin, where required, providing 3,600 cu. ft. of storage per acre drained, or equivalent control measures for drainage locations that serve an area with 10 or more disturbed acres at one time, not including offsite areas.
- 4.4.5.2. **Excavation of Sediment and Debris.** Remove sediment and debris when accumulation affects the performance of the devices, after a rain, and when directed.
- 4.4.6. **Construction Perimeter Fence.** Construct, align, and locate fencing as shown on the plans or as directed.
- 4.4.6.1. **Installation of Posts.** Embed posts 18 in. deep or adequately anchor in rock, with a spacing of 8 to 10 ft.
- 4.4.6.2. **Wire Attachment.** Attach the top wire to the posts at least 3 ft. from the ground. Attach the lower wire midway between the ground and the top wire.
- 4.4.6.3. **Flag Attachment.** Attach flagging to both wire strands midway between each post. Use flagging at least 18 in. long. Tie flagging to the wire using a square knot.
- 4.4.7. **Sandbags for Erosion Control.** Construct a berm or dam of sandbags that will intercept sediment-laden storm water runoff from disturbed areas, create a retention pond, detain sediment, and release water in sheet flow. Fill each bag with sand so that at least the top 6 in. of the bag is unfilled to allow for proper tying of the open end. Place the sandbags with their tied ends in the same direction. Offset subsequent rows of sandbags 1/2 the length of the preceding row. Place a single layer of sandbags downstream as a secondary debris trap. Place additional sandbags as necessary or as directed for supplementary support to berms or dams of sandbags or earth.
- 4.4.8. **Temporary Sediment-Control Fence.** Provide temporary sediment-control fence near the downstream perimeter of a disturbed area to intercept sediment from sheet flow. Incorporate the fence into erosion-control measures used to control sediment in areas of higher flow. Install the fence as shown on the plans, as specified in this Section, or as directed.
- 4.4.8.1. **Installation of Posts.** Embed posts at least 18 in. deep, or adequately anchor, if in rock, with a spacing of 6 to 8 ft. and install on a slight angle toward the runoff source.
- 4.4.8.2. **Fabric Anchoring.** Dig trenches along the uphill side of the fence to anchor 6 to 8 in. of fabric. Provide a minimum trench cross-section of 6 × 6 in. Place the fabric against the side of the trench and align approximately 2 in. of fabric along the bottom in the upstream direction. Backfill the trench, then hand-tamp.
- 4.4.8.3. **Fabric and Net Reinforcement Attachment.** Attach the reinforcement to wooden posts with staples, or to steel posts with T-clips, in at least 4 places equally spaced unless otherwise shown on the plans. Sewn

vertical pockets may be used to attach reinforcement to end posts. Fasten the fabric to the top strand of reinforcement by hog rings or cord every 15 in. or less.

- 4.4.8.4. **Fabric and Net Splices.** Locate splices at a fence post with a minimum lap of 6 in. attached in at least 6 places equally spaced unless otherwise shown on the plans. Do not locate splices in concentrated flow areas.

Requirements for installation of used temporary sediment-control fence include the following:

- fabric with minimal or no visible signs of biodegradation (weak fibers),
- fabric without excessive patching (more than 1 patch every 15 to 20 ft.),
- posts without bends, and
- backing without holes.

- 4.4.9. **Biodegradable Erosion Control Logs.** Install biodegradable erosion control logs near the downstream perimeter of a disturbed area to intercept sediment from sheet flow. Incorporate the biodegradable erosion control logs into the erosion measures used to control sediment in areas of higher flow. Install, align, and locate the biodegradable erosion control logs as specified below, as shown on the plans, or as directed.

Secure biodegradable erosion control logs in a method adequate to prevent displacement as a result of normal rain events, prevent damage to the logs, and as approved, such that flow is not allowed under the logs. Temporarily removing and replacing biodegradable erosion logs as to facilitate daily work is allowed at the Contractor's expense.

- 4.4.10. **Vertical Tracking.** Perform vertical tracking on slopes to temporarily stabilize soil. Provide equipment with a track undercarriage capable of producing a linear soil impression measuring a minimum of 12 in. long × 2 to 4 in. wide × 1/2 to 2 in. deep. Do not exceed 12 in. between track impressions. Install continuous linear track impressions where the 12 in. length impressions are perpendicular to the slope. Vertical tracking is required on projects where soil disturbing activities have occurred unless otherwise approved.

- 4.5. **Monitoring and Documentation.** Monitor the control measures on a daily basis as long as there are BMPs in place and/or soil disturbing activities are evident to ensure compliance with the SWP3 and TPDES General Permit TXR150000. During time suspensions when work is not occurring or contract non-work days, daily inspections are not required unless a rain event has occurred. Monitoring will consist of, but is not limited to, observing, inspecting, and documenting site locations with control measures and discharge points to provide maintenance and inspection of controls as described in the SWP3. Keep written records of daily monitoring. Document in the daily monitoring report the control measure condition, the date of inspection, required corrective actions, responsible person for making the corrections, and the date corrective actions were completed. Maintain records of all monitoring reports at the project site or at an approved place. Provide copies within 7 days. Together, the CRPE and an Engineer's representative will complete the Construction Stage Gate Checklist on a periodic basis as directed.

5. MEASUREMENT

- 5.1. **Rock Filter Dams.** Installation or removal of rock filter dams will be measured by the foot or by the cubic yard. The measured volume will include sandbags, when used.
- 5.1.1. **Linear Measurement.** When rock filter dams are measured by the foot, measurement will be along the centerline of the top of the dam.
- 5.1.2. **Volume Measurement.** When rock filter dams are measured by the cubic yard, measurement will be based on the volume of rock computed by the method of average end areas.
- 5.1.2.1. **Installation.** Measurement will be made in final position.
- 5.1.2.2. **Removal.** Measurement will be made at the point of removal.

- 5.2. **Temporary Pipe Slope Drains.** Temporary pipe slope drains will be measured by the foot.
- 5.3. **Temporary Paved Flumes.** Temporary paved flumes will be measured by the square yard of surface area. The measured area will include the energy dissipater at the flume outlet.
- 5.4. **Construction Exits.** Construction exits will be measured by the square yard of surface area.
- 5.5. **Earthwork for Erosion and Sediment Control.**
- 5.5.1. **Equipment and Labor Measurement.** Equipment and labor used will be measured by the actual number of hours the equipment is operated and the labor is engaged in the work.
- 5.5.2. **Volume Measurement.**
- 5.5.2.1. **In Place.**
- 5.5.2.1.1. **Excavation.** Excavation will be measured by the cubic yard in its original position and the volume computed by the method of average end areas.
- 5.5.2.1.2. **Embankment.** Embankment will be measured by the cubic yard in its final position by the method of average end areas. The volume of embankment will be determined between:
- the original ground surfaces or the surface upon that the embankment is to be constructed for the feature and
 - the lines, grades and slopes of the accepted embankment for the feature.
- 5.5.2.2. **In Vehicles.** Excavation and embankment quantities will be combined and paid for under "Earthwork (Erosion and Sediment Control, In Vehicle)." Excavation will be measured by the cubic yard in vehicles at the point of removal. Embankment will be measured by the cubic yard in vehicles measured at the point of delivery. Shrinkage or swelling factors will not be considered in determining the calculated quantities.
- 5.6. **Construction Perimeter Fence.** Construction perimeter fence will be measured by the foot.
- 5.7. **Sandbags for Erosion Control.** Sandbags will be measured as each sandbag or by the foot along the top of sandbag berms or dams.
- 5.8. **Temporary Sediment-Control Fence.** Installation or removal of temporary sediment-control fence will be measured by the foot.
- 5.9. **Biodegradable Erosion Control Logs.** Installation or removal of biodegradable erosion control logs will be measured by the foot along the centerline of the top of the control logs.
- 5.10. **Vertical Tracking.** Vertical tracking will not be measured or paid for directly but is considered subsidiary to this item.

6. PAYMENT

The following will not be paid for directly but are subsidiary to pertinent Items:

- erosion-control measures for Contractor project-specific locations (PSLs) inside and outside the right of way (such as construction and haul roads, field offices, equipment and supply areas, plants, and material sources);
- removal of litter, unless a separate pay item is shown on the plans;
- repair to devices and features damaged by Contractor operations;
- added measures and maintenance needed due to negligence, carelessness, lack of maintenance, and failure to install permanent controls;

- removal and reinstallation of devices and features needed for the convenience of the Contractor;
- finish grading and dressing upon removal of the device; and
- minor adjustments including but not limited to plumbing posts, reattaching fabric, minor grading to maintain slopes on an erosion embankment feature, or moving small numbers of sandbags.

Stabilization of disturbed areas will be paid for under pertinent Items except vertical tacking which is subsidiary.

Furnishing and installing pipe for outfalls associated with sediment traps and ponds will not be paid for directly but is subsidiary to the excavation and embankment under this Item.

6.1. **Rock Filter Dams.** The work performed and materials furnished in accordance with this Item and measured as provided under "Measurement" will be paid for at the unit price bid as follows:

6.1.1. **Installation.** Installation will be paid for as "Rock Filter Dams (Install)" of the type specified. This price is full compensation for furnishing and operating equipment, finish backfill and grading, lacing, proper disposal, labor, materials, tools, and incidentals.

6.1.2. **Removal.** Removal will be paid for as "Rock Filter Dams (Remove)." This price is full compensation for furnishing and operating equipment, proper disposal, labor, materials, tools, and incidentals.

When the Engineer directs that the rock filter dam installation or portions thereof be replaced, payment will be made at the unit price bid for "Rock Filter Dams (Remove)" and for "Rock Filter Dams (Install)" of the type specified. This price is full compensation for furnishing and operating equipment, finish backfill and grading, lacing, proper disposal, labor, materials, tools, and incidentals.

6.2. **Temporary Pipe Slope Drains.** The work performed and materials furnished in accordance with this Item and measured as provided under "Measurement" will be paid for at the unit price bid for "Temporary Pipe Slope Drains" of the size specified. This price is full compensation for furnishing materials, removal and disposal, furnishing and operating equipment, labor, tools, and incidentals.

Removal of temporary pipe slope drains will not be paid for directly but is subsidiary to the installation Item. When the Engineer directs that the pipe slope drain installation or portions thereof be replaced, payment will be made at the unit price bid for "Temporary Pipe Slope Drains" of the size specified, which is full compensation for the removal and reinstallation of the pipe drain.

Earthwork required for the pipe slope drain installation, including construction of the sediment trap, will be measured and paid for under "Earthwork for Erosion and Sediment Control."

Riprap concrete or stone, when used as an energy dissipater or as a stabilized sediment trap, will be measured and paid for in accordance with Item 432, "Riprap."

6.3. **Temporary Paved Flumes.** The work performed and materials furnished in accordance with this Item and measured as provided under "Measurement" will be paid for at the unit price bid for "Temporary Paved Flume (Install)" or "Temporary Paved Flume (Remove)." This price is full compensation for furnishing and placing materials, removal and disposal, equipment, labor, tools, and incidentals.

When the Engineer directs that the paved flume installation or portions thereof be replaced, payment will be made at the unit prices bid for "Temporary Paved Flume (Remove)" and "Temporary Paved Flume (Install)." These prices are full compensation for the removal and replacement of the paved flume and for equipment, labor, tools, and incidentals.

Earthwork required for the paved flume installation, including construction of a sediment trap, will be measured and paid for under "Earthwork for Erosion and Sediment Control."

- 6.4. **Construction Exits.** Contractor-required construction exits from off right of way locations or on-right of way PSLs will not be paid for directly but are subsidiary to pertinent Items.

The work performed and materials furnished in accordance with this Item and measured as provided under "Measurement" for construction exits needed on right of way access to work areas required by the Department will be paid for at the unit price bid for "Construction Exits (Install)" of the type specified or "Construction Exits (Remove)." This price is full compensation for furnishing and placing materials, excavating, removal and disposal, cleaning vehicles, labor, tools, and incidentals.

When the Engineer directs that a construction exit or portion thereof be removed and replaced, payment will be made at the unit prices bid for "Construction Exit (Remove)" and "Construction Exit (Install)" of the type specified. These prices are full compensation for the removal and replacement of the construction exit and for equipment, labor, tools, and incidentals.

Construction of sediment traps used in conjunction with the construction exit will be measured and paid for under "Earthwork for Erosion and Sediment Control."

- 6.5. **Earthwork for Erosion and Sediment Control.**

- 6.5.1. **Initial Earthwork for Erosion and Sediment Control.** The work performed and materials furnished in accordance with this Item and measured as provided under "Measurement" will be paid for at the unit price bid for "Excavation (Erosion and Sediment Control, In Place)," "Embankment (Erosion and Sediment Control, In Place)," "Excavation (Erosion and Sediment Control, In Vehicle)," "Embankment (Erosion and Sediment Control, (In Vehicle)," or "Earthwork (Erosion and Sediment Control, In Vehicle)."

This price is full compensation for excavation and embankment including hauling, disposal of material not used elsewhere on the project; embankments including furnishing material from approved sources and construction of erosion-control features; and equipment, labor, tools, and incidentals.

Sprinkling and rolling required by this Item will not be paid for directly but will be subsidiary to this Item.

- 6.5.2. **Maintenance Earthwork for Erosion and Sediment Control for Cleaning and Restoring Control Measures.** The work performed and materials furnished in accordance with this Item and measured as provided under "Measurement" will be paid under a Contractor Force Account Item from invoice provided to the Engineer.

This price is full compensation for excavation, embankment, and re-grading including removal of accumulated sediment in various erosion control installations as directed, hauling, and disposal of material not used elsewhere on the project; excavation for construction of erosion-control features; embankments including furnishing material from approved sources and construction of erosion-control features; and equipment, labor, tools, and incidentals.

Earthwork needed to remove and obliterate erosion-control features will not be paid for directly but is subsidiary to pertinent Items unless otherwise shown on the plans.

Sprinkling and rolling required by this Item will not be paid for directly but will be subsidiary to this Item.

- 6.6. **Construction Perimeter Fence.** The work performed and materials furnished in accordance with this Item and measured as provided under "Measurement" will be paid for at the unit price bid for "Construction Perimeter Fence." This price is full compensation for furnishing and placing the fence; digging, fence posts, wire, and flagging; removal and disposal; and materials, equipment, labor, tools, and incidentals.

Removal of construction perimeter fence will be not be paid for directly but is subsidiary to the installation Item. When the Engineer directs that the perimeter fence installation or portions thereof be removed and replaced, payment will be made at the unit price bid for "Construction Perimeter Fence," which is full compensation for the removal and reinstallation of the construction perimeter fence.

- 6.7. **Sandbags for Erosion Control.** Sandbags will be paid for at the unit price bid for “Sandbags for Erosion Control” (of the height specified when measurement is by the foot). This price is full compensation for materials, placing sandbags, removal and disposal, equipment, labor, tools, and incidentals.
- Removal of sandbags will not be paid for directly but is subsidiary to the installation Item. When the Engineer directs that the sandbag installation or portions thereof be replaced, payment will be made at the unit price bid for “Sandbags for Erosion Control,” which is full compensation for the reinstallation of the sandbags.
- 6.8. **Temporary Sediment-Control Fence.** The work performed and materials furnished in accordance with this Item and measured as provided under “Measurement” will be paid for at the unit price bid as follows:
- 6.8.1. **Installation.** Installation will be paid for as “Temporary Sediment-Control Fence (Install).” This price is full compensation for furnishing and operating equipment finish backfill and grading, lacing, proper disposal, labor, materials, tools, and incidentals.
- 6.8.2. **Removal.** Removal will be paid for as “Temporary Sediment-Control Fence (Remove).” This price is full compensation for furnishing and operating equipment, proper disposal, labor, materials, tools, and incidentals.
- 6.9. **Biodegradable Erosion Control Logs.** The work performed and materials furnished in accordance with this Item and measured as provided under “Measurement” will be paid for at the unit price bid as follows:
- 6.9.1. **Installation.** Installation will be paid for as “Biodegradable Erosion Control Logs (Install)” of the size specified. This price is full compensation for furnishing and operating equipment finish backfill and grading, staking, proper disposal, labor, materials, tools, and incidentals.
- 6.9.2. **Removal.** Removal will be paid for as “Biodegradable Erosion Control Logs (Remove).” This price is full compensation for furnishing and operating equipment, proper disposal, labor, materials, tools, and incidentals.
- 6.10. **Vertical Tracking.** Vertical tracking will not be measured or paid for directly but is considered subsidiary to this Item.

Item 508

Constructing Detours



1. DESCRIPTION

Construct and maintain detours. Remove detours when required.

2. MATERIALS

2.1. **Embankment.** Use roadway excavation for embankment material or use material from other approved sources.

2.2. **Temporary Drainage Pipe.** Furnish pipe required for temporary drainage in accordance with details shown on the plans or as directed. Pipe will become the property of the Contractor upon removal.

Temporary use of permanent pipe is allowable if the sequence of work permits. If pipe used temporarily is damaged so that it is not acceptable in accordance with applicable Items, it will not be acceptable for incorporation in the final project. The damaged pipe remains the property of the Contractor.

2.3. **Base and Surfacing.** Furnish base and surfacing materials in accordance with Items as shown on the plans.

3. CONSTRUCTION

Construct the detour at the locations and to the lines, grades, and typical sections shown on the plans or as directed, in accordance with pertinent Items. Maintain detours for public travel in a safe and passable condition. Public traffic safety and convenience is essential. Maintain detours in accordance with Section 7.2.4., "Public Safety and Convenience"; Article 7.17., "Contractor's Responsibility for Work"; and this Item.

Remove detours after they are no longer needed for traffic. Removed materials will become the property of the Contractor unless otherwise shown on the plans or directed. Dispose of the materials off the right of way, unless otherwise directed, in accordance with federal, state, and local requirements. If desired, dispose of materials by spreading along the adjacent roadway slopes if allowed. Salvage or stockpile in accordance with pertinent Items if embankment, base, or surfacing is to be reused within the roadway construction or stockpiled for future use.

4. MEASUREMENT

This Item will be measured by the square yard of pavement area, or surface area if not paved.

5. PAYMENT

The work performed and materials furnished in accordance with this Item and measured as provided under "Measurement" will be paid for at the unit price bid for "Constructing Detours," for Constructing Detours by Type as shown on the plans, or for "Constructing Detours (EBSS)." Embankment Base Surface Separate (EBSS) is used when embankment, base, and surface are paid for separately.

The price bid for "Constructing Detours" or for Constructing Detours by Type as shown on the plans is full compensation for furnishing all materials required, including embankment, base, and surfacing; excavation and hauling of excavated material; sprinkling and compacting; furnishing, installing, and removing drainage structures; removal of detour; disposal of materials; and equipment, labor, tools, and incidentals.

The price bid for "Construction Detours (EBSS)" is full compensation for furnishing, installing, and removing drainage structures; removal of detour; disposal of materials; and equipment, labor, tools, and incidentals, except that embankment, flexible base, and surfacing will be measured and paid for in accordance with other pertinent Items.

Maintenance of detours constructed will not be paid for directly but will be subsidiary to this Item. Maintenance of pavement on detours that use existing pavement will be paid for in accordance with Article 7.17., "Contractor's Responsibility for Work."

When the plans require the base and surfacing to be removed and incorporated in the final roadway or stockpiled after use on the detour, the work will be performed, measured, and paid for in accordance with the pertinent Items shown for salvaging, replacing, or stockpiling materials.

All other items not specifically addressed in this Article will be paid for under pertinent Items unless otherwise shown on the plans.

Item 510

One-Way Traffic Control



1. DESCRIPTION

Provide one-way traffic control using one of the methods shown on the plans.

2. WORK METHODS

- 2.1. **Flagger Control Method.** Furnish flaggers in accordance with the requirements of Article 7.2., "Safety," at all entry points to the work zone, to stop traffic. Furnish a Stop/Slow paddle that meets the requirements of the TMUTCD for each flagger. If desired, use Automated Flagger Assistance Devices if approved.
- 2.2. **Pilot Car Method.** Furnish a licensed driver and pilot vehicle with required signs attached. Furnish flaggers on each approach to the activity area to control traffic. Provide Stop/Slow paddles and signs that meet the requirements of the TMUTCD. Instruct drivers to follow the pilot vehicle and to not pass the cars ahead.
- 2.3. **Portable Traffic Signal Method.** Furnish, operate, and maintain new or used portable traffic signal units. Assure used units are in good working condition and are approved before use. A list of approved units can be found in the Department's *Compliant Work Zone Traffic Control Device List*. Units will remain the property of the Contractor.

3. MEASUREMENT

When shown on the plans as a bid item, this Item will be measured as follows:

- 3.1. **Flagger Control Method.** By the actual number of hours flaggers are engaged in flagging activities. Each flagger will be measured separately.
- 3.2. **Pilot Car Method.** By the actual number of hours of use for the combination of flaggers and pilot vehicle.
- 3.3. **Portable Traffic Signal Method.** By the month, including 2 units operated by a single controller set up and operational on the worksite.

4. PAYMENT

Unless otherwise shown on the plans, the work performed and materials furnished in accordance with this Item will not be paid for directly but will be subsidiary to pertinent Items.

When shown on the plans as a bid item, the work performed and materials furnished in accordance with this Item and measured as provided under "Measurement" will be paid for at the unit price bid for the method specified. This price is full compensation for furnishing and operating equipment, pilot car, pilot vehicle driver, flaggers, signs, labor, tools, and incidentals. Payment for Portable Traffic Signal units and Portable Traffic Signals will be full compensation for the units, set up, relocating, removing, replacing parts, batteries, fuel, oil, and incidentals.

Item 512

Portable Traffic Barrier



1. DESCRIPTION

Furnish, install, move, and remove portable traffic barrier.

2. MATERIALS

2.1. Furnished by the Contractor.

2.1.1. Concrete. Furnish barrier of the class of concrete shown and using materials that meet the pertinent requirements of the following Items:

- Item 420, "Concrete Substructures"
- Item 421, "Hydraulic Cement Concrete"
- Item 424, "Precast Concrete Structural Members (Fabrication)"
- Item 440, "Reinforcement for Concrete"
- Item 442, "Metal for Structures"

2.1.2. Steel. Barrier sections will be furnished when shown on the plans. Barrier sections must meet the crash testing requirements of NCHRP 350 or MASH TL-3 or TL-4 specifications as per test matrix for Longitudinal Barriers.

2.1.3. Concrete and Steel. When barrier is to be furnished and retained by the Contractor, products from nonapproved sources or previously used products may be provided if the Contractor submits written certification that the barrier sections and materials substantially conform to the requirements of this Item. The Engineer may approve the use of the product if:

- the barrier sections substantially meet typical cross-section dimension requirements,
- there is no evidence of structural damage such as major spalls or cracks,
- the general condition of both the barrier sections and their connectors is acceptable,
- the barrier is new, and
- the barrier is being reused.

2.2. Furnished by the Department. Department-furnished barrier sections will be at a stockpile location or an existing traffic barrier installation shown on the plans.

3. CONSTRUCTION

Notify the Engineer of the location of the casting site and the date on which the work will begin. Multi-project fabrication plants as defined in Item 424, "Precast Concrete Structural Members (Fabrication)," that produce concrete traffic barrier, except temporary barrier furnished and retained by the Contractor, must be qualified in accordance with DMS-7350, "Qualification Procedure for Multi-Project Fabrication Plants of Precast Concrete Traffic Barrier." See the Department's MPL for approved fabricators. Construct barrier in accordance with Item 420, "Concrete Substructures," to the dimensions and cross-sections shown on the plans. Provide forms and cure concrete in accordance with Item 424, "Precast Concrete Structural Members (Fabrication)."

Provide a rough texture to the bottom surface of Single Slope or F-Shape barriers and to the top of Low Profile barriers similar to a wood float finish.

Remove formwork after the concrete has reached sufficient strength to prevent physical damage to the member. Move barrier sections to a storage area and place them on blocking to prevent damage when they have attained sufficient strength to permit handling without causing visible damage.

Produce precast barrier to the tolerances given in Table 1 unless otherwise shown on the plans.

Table 1
Precast Barrier Tolerances

Dimension	Tolerance
Length	±1 in.
Insert Placement	±1/2 in.
Horizontal Alignment	±1/8 in. per 10 feet of length
Deviation of Ends:	
Horizontal Skew	±1/4 in.
Vertical Batter	±1/8 in. per foot of depth

Install the barrier sections in accordance with the details shown on the plans or as directed.

After use, stockpile barrier sections and connection hardware that are to be retained by the Department at the location shown on the plans or as otherwise directed. Obtain assembly and installation information for the portable steel traffic barrier from the manufacturer, and provide the Engineer with an installation and repair manual specific to the portable steel traffic barrier.

Repair or replace all traffic barrier or connecting hardware damaged by the Contractor's operations at the Contractor's expense.

Repair or replace any pavement damaged in the process of installing, moving, or removing barrier sections at the Contractor's expense.

4. MEASUREMENT

This Item will be measured by the foot based on the nominal lengths of the barrier sections.

5. PAYMENT

The work performed and materials furnished in accordance with this Item and measured as provided under "Measurement" will be paid for at the unit price as follows:

- For concrete barrier only, bid for "Portable Traffic Barrier" of the work category (Furnish and Install, Designated Source, Move, Stockpile, or Remove), shape (e.g., Single Slope, F-Shape, or Low Profile) and Type (1, 2, 3, etc.) of barrier sections specified. This price includes equipment, labor, tools, and incidentals.
- For concrete and steel barrier, bid for "Portable Traffic Barrier" of the work category (Furnish and Install, Designated Source, Move, Stockpile, or Remove), shape (e.g., Single Slope, F-Shape, or Low Profile) and Type (1, 2, 3, etc.) of barrier sections specified or "Steel". This price includes equipment, labor, tools, and incidentals.

- 5.1. **Furnish and Install.** This price is full compensation for furnishing and installing barrier sections and connection hardware.
- 5.2. **Designated Source.** This price is full compensation for delivering and installing Department-furnished barrier sections and connection hardware from a designated source.
- 5.3. **Move.** This price is full compensation for moving barrier section installations on the project from one location to another (including disassembly and reassembly costs), moving barrier sections from an installation on the project to a temporary storage area (including disassembly costs), and moving barrier sections from a temporary storage area to an installation site on the project (including assembly costs).

- 5.4. **Stockpile.** This price is full compensation for removing barrier sections and connection hardware from the project and delivering to the Department stockpile area shown on the plans or as directed.
- 5.5. **Remove.** This price is full compensation for removing barrier and connection hardware from the project and retained by the Contractor.

Item 514

Permanent Concrete Traffic Barrier



1. DESCRIPTION

Construct permanent concrete traffic barrier.

2. MATERIALS

Furnish new barrier using materials that meet the pertinent requirements of the following Items:

- Item 416, "Drilled Shaft Foundations"
- Item 420, "Concrete Substructures"
- Item 421, "Hydraulic Cement Concrete"
- Item 424, "Precast Concrete Structural Members (Fabrication)"
- Item 440, "Reinforcement for Concrete"
- Item 442, "Metal for Structures"

Furnish the class of concrete shown on the plans.

3. CONSTRUCTION

- 3.1. **General.** Perform excavation and embankment work in accordance with Item 400, "Excavation and Backfill for Structures," except for measurement and payment.

Place reinforcing steel in accordance with Item 440, "Reinforcement for Concrete." Welding of additional bars to the reinforcing cage is allowable, if approved, when slipform placement is used. Weld in accordance with Item 448, "Structural Field Welding."

Cast barrier in place, slipform barrier, or construct barrier using precast concrete sections unless otherwise shown on the plans. Use forms meeting the requirements of Item 424, "Precast Concrete Structural Members (Fabrication)" for precast sections. Wood forms are allowable for curves and transitions. Construct formwork in accordance with Item 420, "Concrete Substructures."

Multi-project fabrication plants (as defined in Item 424, "Precast Concrete Structural Members (Fabrication)") that produce concrete traffic barrier must be qualified in accordance with DMS-7350, "Qualification Procedure for Multi-Project Fabrication Plants of Precast Concrete Traffic Barrier." See the Department's MPL for approved fabricators. Construct drilled shaft foundations in accordance with Item 416, "Drilled Shaft Foundations," when required.

Construct barrier in accordance with Item 420, "Concrete Substructures." Form-cure or water-cure concrete, except for precast sections, for at least 4 days, or cure with Type 1-D or Type 2 membrane curing compound. Cure precast sections in accordance with Item 424, "Precast Concrete Structural Members (Fabrication)."

Remove concrete, mortar, oil, and other substances leaked onto the roadway.

- 3.2. **Cast-in-Place Barrier.**

- 3.2.1. **Conventionally Formed Barrier.** Accurately set forms for conventionally formed barrier. Secure the forms in a manner that is not detrimental to roadway pavement and will maintain barrier in a true position during concrete placement. Remove forms after the concrete has reached sufficient strength to prevent physical damage to the barrier.

- 3.2.2. **Slipformed Barrier.** Ensure slipformed barriers are within a vertical and horizontal alignment tolerance of $\pm 1/4$ in. in 10 ft. Construct barrier with a smooth and uniform appearance. Remove and replace unsatisfactory barrier at the Contractor's expense. Consolidate concrete so it is free of honeycomb. Provide concrete with a consistency that will maintain the shape of the barrier without support. Minimize starting and stopping of the slipform operation by ensuring a continuous supply of concrete. Provide a wire line to maintain vertical and horizontal alignment of the slipform machine. Attach a grade line gauge or pointer to the machine so a continuous comparison can be made between the barrier being placed and the established grade line. Do not exceed the manufacturer's recommended speed for the slipform machine. Rails or supports at the required grade are allowed instead of sensor controls.
- 3.3. **Precast Sections.** Notify the Engineer of the location of the casting site and date on which work will begin if precast sections are used. Form cure concrete until the concrete has reached sufficient strength to permit handling without visible cracks or other damage to the sections. Produce precast barrier sections to the tolerances of Table 1 unless otherwise shown on the plans.

Table 1
Precast Barrier Tolerances

Dimension	Tolerance
Length	± 1 in.
Insert Placement	$\pm 1/2$ in.
Horizontal Alignment	$\pm 1/8$ in. per 10 feet of length
Deviation of Ends	
Horizontal Skew	$\pm 1/4$ in.
Vertical Batter	$\pm 1/8$ in. per foot of depth

Repair or replace concrete traffic barrier damaged during fabrication, curing, handling or placing, as directed.

4. MEASUREMENT

This Item will be measured by the foot. Barriers with 2 longitudinal half-sections will be measured once along the centerline between the 2 halves.

5. PAYMENT

The work performed and materials furnished in accordance with this Item and measured as provided under "Measurement" will be paid for at the unit price bid for "Permanent Concrete Traffic Barrier" of the shape (e.g., Single Slope or "F" Shape), Type (1, 2, 3, etc.), and height (for Single Slope) specified. This price is full compensation for furnishing and placing materials, including footings and drilled-shaft anchors; and excavation and embankment, equipment, labor, tools, and incidentals.

Unless shown on the plans as a bid item, asphalt concrete pavement used for lateral support will not be paid for directly but will be subsidiary to this Item.

Item 520

Weighing and Measuring Equipment



1. DESCRIPTION

Provide weighing and measuring equipment for materials measured or proportioned by weight or volume.

2. EQUIPMENT

Provide certified scales, scale installations, and measuring equipment meeting the requirements of *NIST Handbook 44*, except that the required accuracy must be 0.4% of the material being weighed or measured.

Provide personnel, facilities, and equipment for checking the scales as approved. Check all weighing and measuring equipment after each move and at least once each 6 mo. or when requested.

Calibrate all scales using weights certified by the Texas Department of Agriculture (TDA) or an equivalent agency as approved. Provide a written calibration report from a scale mechanic for all calibrations. Cease plant operations during the checking operation. Do not use inaccurate or inadequate scales. Bring performance errors as close to zero as practicable when adjusting equipment.

Furnish enough certified weights to check the accuracy and sensitivity of the scales. Insulate scales against shock, vibrations, or movement of other operating equipment. Provide an automated ticket printout for each truckload of material on a daily basis where payment is determined by weight. Each loading ticket must show the ticket number, truck number, gross weight, tare weight, and net weight.

Provide a summary spreadsheet that lists separately the ticket number, truck number, gross weight, tare weight, net weight, overload weight, and payment weight amounts as shown in Table 1 if required on the plans for materials paid by the ton. Provide this spreadsheet:

- for each lot when materials are paid for in increments of sublots or lots, and
- daily for other materials.

Provide the totals for net weight and overload amounts to be deducted for all summary sheets within 2 days of delivery of materials. Include the overload deduction in the total amount reported for payment. Submissions are subject to verification.

Table 1
Example Spreadsheet

Ticket No.	Truck No.	Gross Wt.	Tare Wt.	Net Wt.	Overload Wt.	Payment Wt.
				Totals	Totals	Totals

Furnish leak-free weighing containers large enough to hold a complete batch of the material being measured.

- 2.1. **Truck Scales.** Furnish platform truck scales capable of weighing the entire truck or truck-trailer combination in a single draft.

- 2.2. **Aggregate Batching Scales.** Equip scales used for weighing aggregate with a quick adjustment at zero that provides for any change in tare. Provide a visual means that indicates the required weight for each aggregate.
- 2.3. **Suspended Hopper.** Provide a means for the addition or the removal of small amounts of material to adjust the quantity to the exact weight per batch. Ensure the scale equipment is level.
- 2.4. **Belt Scales.** Use belt scales for proportioning aggregate that are accurate to within 1.0% based on the average of 3 test runs, where no individual test run exceeds 2.0% when checked in accordance with Tex-920-K.
- 2.5. **Asphalt Material Meter.** Provide an asphalt material meter with an automatic digital display of the volume or weight of asphalt material. Verify the accuracy of the meter in accordance with Tex-921-K. Ensure the accuracy of the meter is within 0.4% when using the asphalt meter for payment purposes. Ensure the accuracy of the meter is within 1.0% when used to measure component materials only and not for payment.
- 2.6. **Liquid Asphalt Additive Meters.** Provide a means to check the accuracy of meter output for asphalt primer, fluxing material, and liquid additives. Furnish a meter that reads in increments of 0.1 gal. or less. Verify accuracy of the meter in accordance with Tex-923-K. Ensure the accuracy of the meter within 5.0%.
- 2.7. **Particulate Solid and Slurry Additive Meters.** Provide a means to check the accuracy of meter output for particulate solids (such as hydrated lime or mineral filler) and slurries (such as hydrated lime slurry). Ensure the accuracy of the meter within 5.0%.

3. MEASUREMENT AND PAYMENT

The work performed, materials furnished, equipment, labor, tools, and incidentals will not be measured or paid for directly but will be subsidiary to pertinent items.

Item 528

Colored Textured Concrete and Landscape Pavers



1. DESCRIPTION

- 1.1. **Colored Textured Concrete.** Furnish and place colored textured concrete.
- 1.2. **Landscape Pavers.** Furnish and install landscape pavers.
- 1.3. **Landscape Pavers (Furnished).** Landscape pavers will be furnished by the Department. Load and transport from the location shown on the plans to the project, and install.
- 1.4. **Remove, Store, and Relay Landscape Pavers.** Remove, store, and relay landscape pavers as shown on the plans or as directed. Furnish and lay replacement pavers.

2. MATERIALS

- 2.1. **Colored Textured Concrete.** Furnish materials in accordance with the following:

- Item 420, "Concrete Substructures"
- Item 421, "Hydraulic Cement Concrete"
- Item 440, "Reinforcement for Concrete"

Use Class A concrete unless otherwise shown on the plans.

When approved, use fibers listed on the Department's MPL or fibers meeting the requirements of DMS-4550, "Fibers for Concrete," to replace reinforcing steel in Class A concrete.

Use approved dry-shake color hardener or integral concrete colorant shown on the plans. Provide colored wax as a curing membrane meeting the requirements of ASTM C309 or as shown on the plans.

- 2.2. **Landscape Pavers.** Furnish materials in accordance with the details shown on the plans and the following:

- Item 132, "Embankment"
- Item 247, "Flexible Base"
- Item 275, "Cement Treatment (Road-Mixed)"
- Item 401, "Flowable Backfill"
- Item 421, "Hydraulic Cement Concrete"

- 2.2.1. **Pavers.** Furnish pavers meeting the requirements of ASTM C936; made using normal-weight aggregates conforming to ASTM C33; and conforming to the shape, color, laying pattern, and dimensions shown on the plans. Furnish certification from the manufacturer stating that the interlocking paving units have been tested and meet all the requirements of ASTM C936. Furnish additional paving units when required for testing by the Department.

- 2.2.2. **Bedding Sand.** Furnish fine aggregate as specified in Item 421, "Hydraulic Cement Concrete," with the gradation given in Table 1.

Table 1
Bedding Sand Gradation

Sieve Size	Percent Passing
3/8"	100
#4	85-100
#100	10-30

Spread the sand at a uniform moisture content of 3% to 7%. Protect the sand against rain if it is stockpiled on-site before spreading.

- 2.2.3. **Joint-Filling Sand.** Meet the requirements for bedding sand, except with the gradation given in Table 2.

Table 2
Joint-Filling Sand Gradation

Sieve Size	Percent Passing
#4	100
#8	90–100
#16	60–100
#30	25–70
#50	10–30
#100	2–15
#200	Less than 10

3. CONSTRUCTION

- 3.1. **Colored Textured Concrete.** Prepare for approval a 9-sq. ft., 3-in. thick specimen for each color, pattern, and texture required before beginning work.

Prepare the subgrade, base, or both in accordance with the plans and pertinent Items. Place and screed concrete to the proper grade and wood-float to a uniform surface, in accordance with Item 420, "Concrete Substructures."

Apply colorant in accordance with the manufacturer's recommendations. Apply dry-shake color hardener, if used, evenly to the plastic surface, following the manufacturer's directions. Use at least 65 lb. per 12 square yard. Apply in 2 separate applications and wood-float after each application. Trowel only after the final floating.

Place dies with a repetitive pattern on the concrete surface and hand-tamp to create the required texture or imprint shown on the plans. Use a brick pattern if no texture is specified. Apply colored curing and finishing compound in accordance with the manufacturer's directions.

- 3.2. **Landscape Pavers.**

- 3.2.1. **Removing and Relaying Existing Pavers.** Exercise care when removing existing pavers, making an effort to remove the pavers with minimal damage. Removal by mechanical means is allowed unless otherwise shown on the plans. Ensure that any removed pavers remain in good, reusable condition. Dispose of stained or damaged pavers. Palletize reusable pavers and completely wrap the pavers and pallets with plastic to protect during storage. Safeguard the pavers from theft and/or vandalism while the Contract is in progress. Deliver salvageable excess pavers to a stockpile location on the project unless otherwise shown on the plans. Dispose of unsalvageable pavers in accordance with federal, state, and local regulations. Replace any pavers deemed unusable with new materials as necessary and as directed. Remove paver units damaged during compaction and replace with pavers of equivalent size, shape, and color.

- 3.2.2. **Base Installation.** Perform excavation and embankment work for the subgrade. Replace unsuitable material encountered in the subgrade and compact to a uniform grade. Stabilize subgrade if specified. Place and compact the base to ordinary compaction requirements in accordance with the pertinent Item, and to the depth specified on the plans. Grade the base surface so that the finished grade of the pavers meets the requirements shown on the plans.

- 3.2.3. **Bedding Sand Installation.** Screed a layer of uncompacted sand to a depth of 1 to 1-1/2 in. over the compacted base. Do not use bedding sand for leveling.

Maintain the spread sand in a loose condition and protect against precompaction before and after screeding. Protect screeded sand against accidental precompaction, including compaction by rain or dew. Loosen precompacted sand or screeded sand in advance of the laying face only to an extent to which paving will be

completed that day. Lightly screed the sand in a loose condition to the predetermined depth slightly ahead of laying the paving units.

- 3.2.4. **Paver Installation.** Place paving units on an uncompacted, screeded sand bed to the required laying pattern shown on the plans. Align all joints and provide nominal 1/8-in. gaps between adjacent units.

Place the first row to abut an edge restraint with a gap of 1/8 in. Place at a suitable angle to the edge restraint to achieve the required visual orientation of paving units in the completed pavement. Lay full-size units in each row first, followed by closure units consisting of at least 25% of a full unit. Cut units using a power saw. To fill smaller edge spaces, use a grout mix matching the color of the pavers that consists of 1 part hydraulic cement to 2 parts concrete sand. Use cement and sand that meet Item 421, "Hydraulic Cement Concrete."

Do not allow construction traffic on pavers during installation and compaction.

- 3.2.5. **Paver Compaction.** Provide a high-frequency, low-amplitude mechanical flat plate vibrator compactor with a plate area large enough to cover at least 12 paving units and that can deliver a 3,500- to 5,000-lb. centrifugal compaction force. Compact paving units immediately after placement to achieve consolidation of the sand bedding before any traffic is allowed. Bring to design levels and profiles by at least 2 passes of the plate compactor.

Do not compact within 3 ft. of the laying face. Continue compaction until lipping has been eliminated between the adjoining units. Compact all work to within 3 ft. of the laying face at the completion of each work day.

Spread joint-filling sand as soon as practical after compaction but in all cases before the termination of each work day, before acceptance of the day's work, and before permitting construction traffic. Allow joint-filling sand to dry, and then sweep to fill the joints. Compact the pavers and joint-filling sand with a single pass of the compactor.

4. MEASUREMENT

This Item will be measured by the square yard. Removed pavers to be relayed, salvaged, or disposed of will be measured by the square yard in their original position. Replacement pavers will be measured by the square yard in the final position of replacement pavers.

5. PAYMENT

Excavation and embankment will not be paid for directly but will be subsidiary to this Item unless otherwise shown on the plans.

- 5.1. **Colored Textured Concrete.** The work performed and measured as provided under "Measurement" will be paid for at the unit price bid for "Colored Textured Concrete" of the thickness specified. This price is full compensation for surface preparation of subgrade and base; furnishing, placing, finishing, and curing colored, textured concrete; and equipment, labor, materials, tools, and incidentals.

Preparation of approval specimens will not be paid for directly but will be considered subsidiary to this Item. Base under colored textured concrete will be paid for under pertinent Items unless otherwise shown on the plans.

- 5.2. **Landscape Pavers.** The work performed and measured as provided under "Measurement" will be paid for at the unit price bid for "Landscape Pavers." This price is full compensation for furnishing, placing, and compacting pavers; bedding and joint-filling sand; and equipment, labor, materials, tools, and incidentals. Paver units damaged during compaction will be replaced at the Contractor's expense. Base required for landscape pavers will not be paid for directly but will be subsidiary to this Item.

- 5.3. **Landscape Pavers (Furnished).** The work performed and measured as provided under “Measurement” will be paid for at the unit price bid for “Landscape Pavers (Furnished).” This price is full compensation for loading and transporting, placing, and compacting pavers; bedding and joint-filling sand; and equipment, labor, materials, tools, and incidentals. Paver units damaged during loading, transport, or compaction will be replaced at the Contractor’s expense. Base required for landscape pavers will not be paid for directly but will be subsidiary to this Item.
- 5.4. **Removing and Relaying Existing Pavers.** The work performed and measured as provided under “Measurement” will be paid for at the unit price bid for in accordance with “Remove and Relay Pavers” and “Replacement Pavers.” Base required for landscape pavers will not be paid for directly but will be subsidiary to this Item. Paver units damaged during removal, loading, transport, or compaction will be replaced at the Contractor’s expense.
- 5.4.1. **Remove and Relay Pavers.** Removing and relaying pavers will be paid for at the unit price for “Remove and Relay Landscape Pavers.” This price is full compensation for removing and storing pavers; placing and compacting salvaged pavers; preparing bedding; bedding and joint-filling sand; stockpiling salvaged pavers; disposing of pavers; and equipment, labor, materials, tools, and incidentals.
- 5.4.2. **Replacement Pavers.** Furnishing and placement of replacement pavers will be paid for at the unit price bid for “Replacement Pavers.” This price is full compensation for furnishing replacement pavers; placing and compacting pavers; preparing bedding; bedding and joint-filling sand; and equipment, labor, materials, tools, and incidentals.

Item 529

Concrete Curb, Gutter, and Combined Curb and Gutter



1. DESCRIPTION

Construct hydraulic cement concrete curb, gutter, and combined curb and gutter.

2. MATERIALS

Furnish materials conforming to:

- Item 360, "Concrete Pavement"
- Item 420, "Concrete Substructures"
- Item 421, "Hydraulic Cement Concrete"
- Item 440, "Reinforcement for Concrete"

Use Class A concrete or material specified on the plans. Use Grade 8 coarse aggregate for extruded Class A concrete. Use other grades if approved.

When approved, use fibers meeting the requirements of DMS-4550, "Fibers for Concrete," to replace reinforcing steel in Class A concrete. Dose fibers in accordance with the Department's MPL of pre-qualified fibers for concrete.

3. CONSTRUCTION

Provide finished work with a well-compacted mass and a surface free from voids and honeycomb, in the required shape, line, and grade. Round exposed edges with an edging tool of the radius shown on the plans. Mix, place, and cure concrete in accordance with Item 420, "Concrete Substructures." Construct joints at locations shown on the plans. Cure for at least 72 hr.

Furnish and place reinforcing steel in accordance with Item 440, "Reinforcement for Concrete."

Set and maintain a guideline that conforms to alignment data shown on the plans, with an outline that conforms to the details shown on the plans. Ensure that changes in curb grade and alignment do not exceed 1/4 in. between any 2 contacts on a 10-ft. straightedge.

- 3.1. **Conventionally Formed Concrete.** Shape and compact subgrade, foundation, or pavement surface to the line, grade, and cross-section shown on the plans. Lightly sprinkle subgrade or foundation material immediately before concrete placement.

Pour concrete into forms, and strike off with a template 1/4 to 3/8 in. less than the dimensions of the finished curb unless otherwise approved. After initial set, plaster surface with mortar consisting of 1 part hydraulic cement and 2 parts fine aggregate. Brush exposed surfaces to a uniform texture.

Place curbs, gutters, and combined curb and gutters in 50-ft. maximum sections unless otherwise approved.

- 3.2. **Extruded or Slipformed Concrete.** Hand-tamp and sprinkle subgrade or foundation material before concrete placement. Provide clean surfaces for concrete placement. Coat cleaned surfaces, if required, with approved adhesive or coating at the rate of application shown on the plans or as directed. Place concrete with approved self-propelled equipment.

The forming tube of the extrusion machine or the form of the slipform machine must be easily adjustable vertically during the forward motion of the machine to provide variable heights necessary to conform to the established gradeline.

Attach a pointer or gauge to the machine so that a continual comparison can be made between the extruded or slipform work and the grade guideline. Other methods may be used when approved.

Finish surfaces immediately after extrusion or slipforming.

4. MEASUREMENT

This Item will be measured by the foot.

5. PAYMENT

The work performed and materials furnished in accordance with this Item and measured as provided under "Measurement" will be paid for at the unit price bid for "Concrete Curb," "Concrete Curb (Mono)," or "Concrete Curb and Gutter" of the type specified. This price is full compensation for surface preparation of curb foundation, equipment, labor, materials, tools, and incidentals.

Item 530

Intersections, Driveways, and Turnouts



1. DESCRIPTION

Construct and pave intersections, driveways, and turnouts. Pave existing intersections, driveways, and turnouts.

Intersections are considered to be areas off the travel lanes and shoulders of the Contract highway on the intersecting highway on the state system. The intersecting on-system highway work will be paid for under this Item only when shown on the plans.

Driveways are defined as private (residential or commercial) and public (county road and city street) access areas off the travel lanes and shoulders.

Turnouts include but are not limited to mailbox and litter barrel widenings.

2. MATERIALS

Furnish materials that meet the following:

- Item 247, "Flexible Base"
- Item 260, "Lime Treatment (Road-Mixed)"
- Item 263, "Lime Treatment (Plant-Mixed)"
- Item 275, "Cement Treatment (Road-Mixed)"
- Item 276, "Cement Treatment (Plant-Mixed)"
- Item 292, "Asphalt Treatment (Plant-Mixed)"
- Item 316, "Seal Coat"
- Item 330, "Limestone Rock Asphalt Pavement"
- Item 334, "Hot-Mix Cold-Laid Asphalt Concrete Pavement"
- Item 340, "Dense-Graded Hot-Mix Asphalt (Small Quantity)"
- Item 360, "Concrete Pavement"
- Item 421, "Hydraulic Cement Concrete"
- Item 440, "Reinforcement for Concrete"

3. CONSTRUCTION

Construct and pave intersections, driveways, and turnouts, and pave existing intersections, driveways, and turnouts as shown on the plans or as directed. Place materials in accordance with construction Articles of pertinent Items. Provide uninterrupted access to adjacent property unless otherwise directed. Ensure that abrupt elevation changes in driveway or turnout areas that serve as sidewalks do not exceed 1/4 in. and that the sidewalk area cross slope does not exceed 2%. Ready-mix concrete and hand finishing will be permitted when concrete pavement is specified unless otherwise shown on the plans for intersections.

4. MEASUREMENT

This Item will be measured by the square yard of the final pavement surface.

5. PAYMENT

The work performed and materials furnished in accordance with this Item and measured as provided under "Measurement" will be paid for at the unit price bid for "Intersections," "Driveways," "Turnouts," "Intersections, Driveways, and Turnouts," or "Driveways and Turnouts" of the surface specified.

This price is full compensation for furnishing and operating equipment; excavation and embankment; base and pavement materials; and labor, materials, tools and incidentals. Drainage structures will be measured and paid for in accordance with the pertinent bid items.

Item 531

Sidewalks



1. DESCRIPTION

Construct hydraulic cement concrete sidewalks.

2. MATERIALS

Furnish materials conforming to the following:

- Item 360, "Concrete Pavement"
- Item 420, "Concrete Substructures"
- Item 421, "Hydraulic Cement Concrete"
- Item 440, "Reinforcement for Concrete"

Use Class A concrete unless otherwise shown on the plans. Use Grade 8 course aggregate for extruded Class A concrete. Use other grades if approved.

3. CONSTRUCTION

Shape and compact subgrade, foundation, or pavement surface to the line, grade, and cross-section shown on the plans. Lightly sprinkle subgrade or foundation material immediately before concrete placement. Hand-tamp and sprinkle foundation when placement is directly on subgrade or foundation materials. Remove and dispose of existing concrete in accordance with Item 104, "Removing Concrete." Provide a clean surface for concrete placement directly on the surface material or pavement.

Mix and place concrete in accordance with the pertinent Items. Hand-finishing is allowed for any method of construction. Finish exposed surfaces to a uniform transverse broom finish surface. Curb ramps must include a detectable warning surface and conform to details shown on the plans. Install joints as shown on the plans. Ensure that abrupt changes in sidewalk elevation do not exceed 1/4 in., sidewalk cross slope does not exceed 2%, curb ramp grade does not exceed 8.3%, and flares adjacent to the ramp do not exceed 10% slope. Ensure that the sidewalk depth and reinforcement are not less than the driveway cross-sectional details shown on the plans where a sidewalk crosses a concrete driveway.

Provide finished work with a well-compacted mass, a surface free from voids and honeycomb, and the required true-to-line shape and grade. Cure for at least 72 hr. in accordance with Item 420, "Concrete Substructures."

3.1. **Conventionally Formed Concrete.** Provide pre-molded or board expansion joints of the thickness shown on the plans for sidewalk section lengths greater than 8 ft. but less than 40 ft., unless otherwise directed. Terminate workday production at an expansion joint.

3.2. **Extruded or Slipformed Concrete.** Provide any additional surface finishing immediately after extrusion or slipforming as required on the plans. Construct joints at locations as shown on the plans or as directed.

4. MEASUREMENT

Sidewalks will be measured by the square yard of surface area. Curb ramps will be measured by the square yard of surface area or by each. A curb ramp consists of the ramp, landing, adjacent flares or side curb, and detectable warning surface as shown on the plans.

5. PAYMENT

The work performed and materials furnished in accordance with this Item and measured as provided under "Measurement" will be paid for at the unit price bid for "Concrete Sidewalks" of the depth specified and "Curb Ramps" of the type specified. This price is full compensation for surface preparation of sidewalk foundation; materials; removal and disposal of existing concrete; excavation, hauling and disposal of excavated material; drilling and doweling into existing concrete curb, sidewalk, and pavement; repair of adjacent street or pavement structure damaged by these operations; and equipment, labor, materials, tools, and incidentals.

Sidewalks that cross and connect to concrete driveways or turnouts will be measured and paid for in accordance with Item 530, "Intersections, Driveways, and Turnouts."

Item 533

Milled Rumble Strips



1. DESCRIPTION

Construct milled rumble strips.

2. EQUIPMENT

Provide a rotary-type cutting head with a maximum outside diameter of 24 in. and a minimum length of 16 in. Arrange cutting tips to provide a relatively smooth cut with approximately 1/16 in. difference in texture deviation. Provide a cutting head with independent suspension from the power unit that will self-align with the shape of the surface and irregularities in the surface. Provide a cutting tool with guides to assure consistent alignment of each cut relative to the roadway and to provide uniformity throughout the project.

3. CONSTRUCTION

Construct milled rumble strips in a uniform position according to dimensions and at locations shown on the plans. The depressions must have well-defined edges, a smooth interior finish, and not snag or tear the finished pavement. Control dust during grinding operations.

Do not place rumble strips across exit or entrance ramps, acceleration and deceleration lanes, crossovers, gore areas, or intersections with other roadways, or at locations not shown on the plans. Correct misplaced rumble strips at the Contractor's expense.

Clean debris from the milled depressions by blowing with compressed air or flushing with water. Remove and dispose of debris by vacuuming or sweeping before opening the adjacent lane to traffic as directed.

4. MEASUREMENT

Rumble strips will be measured longitudinally by the foot. Measurement will only include the actual work performed. Measurement will not include interruptions across ramps, acceleration or deceleration lanes, crossovers, gore areas, or intersections with other roadways.

5. PAYMENT

The work performed in accordance with this Item and as provided for under "Measurement" will be paid for at the unit price bid for "Rumble Strips (Shoulder) and Rumble Strips (Centerline)." This price is full compensation for equipment, labor, materials, tools, and incidentals.

Item 536

Concrete Medians and Directional Islands



1. DESCRIPTION

Construct cast-in-place concrete medians and directional islands.

2. MATERIALS

Furnish materials in accordance with the following:

- Item 420, "Concrete Substructures"
- Item 421, "Hydraulic Cement Concrete"
- Item 440, "Reinforcement for Concrete"
- Item 529, "Concrete Curb, Gutter, and Combined Curb and Gutter"

Use Class A concrete unless otherwise shown on the plans.

When approved, use fibers meeting the requirements of DMS-4550, "Fibers for Concrete," to replace reinforcing steel in Class A concrete. Dose fibers in accordance with the Department's MPL of pre-qualified fibers for concrete.

3. CONSTRUCTION

Provide wood or metal forms securely held in place. Properly position and secure reinforcing steel and dowels. Place concrete for each section on the prepared foundation to line, grade, and cross-section in accordance with Item 420, "Concrete Substructures." Separate sections from adjacent curbs or adjoining sections using expansion or contraction joints of the type and size specified on the plans. A curb section may be used for the perimeter of the median or island when shown. Construct curbs in conformance with Item 529, "Concrete Curb, Gutter, and Combined Curb and Gutter."

Finish exposed surfaces with a wood or metal float after sufficient concrete set. Round exposed edges as shown on the plans.

Remove forms after concrete has set. Point up exposed surfaces. Provide an ordinary surface finish in accordance with Item 427, "Surface Finishes for Concrete." Use mortar consisting of 1 part hydraulic cement and 2 parts fine aggregate to plaster exposed formed surfaces when required. Apply the mortar with a template made to conform to the cross-section shown on the plans.

Cure at least 72 hr. using a method specified in Item 420, "Concrete Substructures."

4. MEASUREMENT

This Item will be measured by the foot or by the square yard to the face of the curb.

5. PAYMENT

The work performed and materials furnished in accordance with this Item and measured as provided under "Measurement" will be paid for at the unit price bid for "Concrete Median" or "Concrete Directional Island." This price is full compensation for preparing foundation surfaces; furnishing and operating equipment; curbs

and gutters used as part of the concrete median or directional island; and labor, materials, tools, and incidentals.

Item 538

Right of Way Markers



1. DESCRIPTION

Install cast-in-place concrete right of way markers.

2. MATERIALS

Furnish materials in accordance with the following:

- Item 421, "Hydraulic Cement Concrete" and
- Item 440, "Reinforcement for Concrete."

The Department will furnish bronze disks.

Provide Class A concrete. When approved, use fibers meeting the requirements of DMS-4550, "Fibers for Concrete," to replace reinforcing steel in Class A concrete. Dose fibers in accordance with the Department's MPL of pre-qualified fibers for concrete.

3. CONSTRUCTION

Cast and finish right of way markers in accordance with Item 420, "Concrete Substructures," and details shown on the plans. Install right of way markers at designated points to the required horizontal and vertical locations. Center the bronze disk within 1/2 in. of the location shown. Reposition any marker that is outside this tolerance.

The Department will provide a survey crew working under the direction of a registered professional land surveyor, licensed to practice in Texas, to make the final alignment checks on each right of way marker installed and to place the right of way location punch mark on the bronze disk unless otherwise shown on the plans. Do not disturb or destroy the original points before installing right of way markers with bronze disks or before placing punch marks.

4. MEASUREMENT

This Item will be measured by each marker.

5. PAYMENT

The work performed and materials furnished in accordance with this Item and measured as provided under "Measurement" will be paid for at the unit price bid for "Right of Way Markers." This price includes materials, labor (including work of the registered professional land surveyor when required by the plans), tools, equipment, and incidentals. Removal and disposal of existing right of way markers will not be paid for directly but is subsidiary to pertinent Items.

Item 540

Metal Beam Guard Fence



1. DESCRIPTION

Furnish, install, replace, or adjust metal beam guard fence consisting of metal beam rail elements, hardware, blocks, and support posts.

2. MATERIALS

Provide samples of metal beam rail elements, terminal sections, bolts, and nuts for compliance testing according to Tex-708-I and Tex-713-I to verify physical and chemical properties meet AASHTO M 180 when directed.

Obtain materials at the locations shown on the plans when the plans designate that the Department will furnish materials.

- 2.1. **Metal Beam Rail Elements.** Furnish new metal beam rail elements, transitions, anchor sections, and terminals that meet the requirements of Table 1 and are from a manufacturer on the Department's MPL of rail element manufacturers.

Type I or II is required, unless otherwise shown on the plans. Base metal for metal beam rail elements must not contain more than 0.04% phosphorous or more than 0.05% sulfur.

Warped or deformed rail elements will be rejected.

Table 1
Rail Element Requirements

Specification	AASHTO M 180
Class	A— Base metal nominal thickness 0.105 in. B— Base metal nominal thickness 0.135 in.
Type	I— Zinc-coated 1.80 oz. per square foot minimum single-spot. II— Zinc-coated 3.60 oz. per square foot minimum single-spot. IV— Weathering Steel (required when shown on the plans).
Shape	W-Beam Thrie Beam W-Beam to Thrie Beam Transition
Markings	Permanently mark each metal beam rail element with the information required in AASHTO M 180. In addition, permanently mark all curved sections of metal beam rail element with the radius of the curved section in the format "R=XX ft." Markings must be on the back of the metal beam rail section away from traffic and visible after erection.

- 2.2. **Posts.** Furnish new round timber, rectangular timber, or rolled steel section posts in accordance with details shown on the plans and the following requirements:

- 2.2.1. **Timber Posts.** Meet the requirements of DMS-7200, "Timber Posts and Blocks for Metal Beam Guard Fence." Purchase from a manufacturer or supplier on the Department's MPL of timber treating plants and suppliers.

- 2.2.2. **Steel Posts.** Provide rolled sections conforming to the material requirements of ASTM A36. Drill or punch posts for standard rail attachment as shown on the plans. Galvanize according to Item 445, "Galvanizing." Low-fill culvert posts may be fabricated as galvanized "blanks" with the rail hole and the final height field

fabricated. Treat all exposed post surfaces caused by the field fabrication in accordance with Section 445.3.5., "Repairs."

- 2.3. **Blocks.** Furnish new rectangular timber or composite blocks in accordance with details shown on the plans and the following requirements:
 - 2.3.1. **Timber.** Meet the requirements of DMS-7200 "Timber Posts and Blocks for Metal Beam Guard Fence." Purchase from a manufacturer or supplier on the Department's MPL of timber treating plants and suppliers.
 - 2.3.2. **Composite.** Meet the requirements of DMS-7210 "Composite Material Posts and Blocks for Metal Beam Guard Fence." Purchase from a manufacturer on the Department's MPL of composite material blocks and posts.
- 2.4. **Fittings.** Furnish new fittings (bolts, nuts, and washers) according to the details shown on the plans and galvanized according to Item 445, "Galvanizing."
- 2.5. **Terminal Connectors.** Furnish new terminal connectors, where required, meeting the material and galvanizing requirements specified for metal beam rail elements.
- 2.6. **Concrete.** Furnish concrete for terminal anchor posts meeting the requirements for Class A concrete as required in Item 421, "Hydraulic Cement Concrete."
- 2.7. **Curb.** If indicated in the details, furnish the curb shown with metal beam guard fence transition as required by Item 529, "Concrete Curb, Gutter, and Combined Curb and Gutter."
- 2.8. **Terminal Anchor Posts.** Furnish new terminal anchor posts from steel conforming to the material requirements of ASTM A36. Fabricate posts according to Item 441, "Steel Structures." Galvanize terminal anchor posts after fabrication according to Item 445, "Galvanizing."
- 2.9. **Driveway Terminal Anchor Posts.** Furnish new terminal anchor posts from steel conforming to the material requirements of ASTM A36. Fabricate posts according to Item 441, "Steel Structures." Galvanize terminal anchor posts after fabrication according to Item 445, "Galvanizing."
- 2.10. **Downstream Anchor Posts.** Furnish new terminal anchor posts consisting of new rectangular timber and new steel foundation tubes according to details shown on the plans.
- 2.11. **Downstream Anchor Hardware.** Furnish new hardware (brackets, plates, struts, cable, etc.) according to the details shown on the plans and galvanized according to Item 445, "Galvanizing."
- 2.12. **Controlled Released Terminal (CRT) Posts.** Furnish new CRT posts according to the details shown on the plans and conforming to the requirements of DMS-7200, "Timber Posts and Blocks for Metal Beam Guard Fence." Purchase from a manufacturer or supplier on the Department's MPL of timber treating plants and suppliers.

3. CONSTRUCTION

Install posts and rail elements according to details shown on the plans.

- 3.1. **Posts.** Install posts by either drilling or driving.
 - 3.1.1. **Drilling.** Drill holes and set posts plumb and firm to the line and grade shown. Backfill posts by thoroughly compacting material to the density of adjacent undisturbed material.
 - 3.1.2. **Driving.** Drive posts plumb with approved power hammers (steam, compressed air, vibratory, or diesel) or gravity hammers to the line and grade shown while preventing damage to the post. Use pilot holes when required and approved. Determine the size and depth of pilot holes based on results of the first few posts

driven. Thoroughly tamp loosened soil around the post, fill voids with suitable material, and thoroughly compact to the density of adjacent undisturbed material.

- 3.2. **Rail Elements.** Erect metal beam rail elements to produce a smooth, continuous rail paralleling the line and grade of the roadway surface or as shown on the plans. Bolt rail elements end-to-end and lap splices in the direction of traffic. Field-drill or punch holes in rail elements for special details, only when approved.
- 3.3. **Short Radius.** Special rail fabrication with a required radius must be as shown on the plans.
- 3.4. **Terminal Anchor Posts.** Embed terminal anchor posts in concrete, unless otherwise shown on the plans.
- 3.5. **Galvanizing Repair.** Repair all parts of galvanized steel posts, washers, bolts, and rail elements after erection where galvanizing has become scratched, chipped, or otherwise damaged. Repair in accordance with Section 445.3.5., "Repairs."
- 3.6. **Guardrail Adjustment.** Work includes vertical adjustment, horizontal shift, and overlap of the rail element to meet the detail shown on the plans.
- 3.7. **Curb.** If indicated in the details, construct the curb shown with metal beam guard fence transition as required by Item 529, "Concrete Curb, Gutter, and Combined Curb and Gutter."
- 3.8. **Driveway Terminal Anchor Posts.** Embed terminal anchor posts in concrete, unless otherwise shown on the plans.

4. MEASUREMENT

- 4.1. **Guard Fence.** Measurement will be by the foot of fence. Fence will be measured on the face of the rail in place, from center-to-center of end splice locations.
- 4.2. **Terminal Anchor Sections.** Measurement will be by each section, complete in place, consisting of a terminal anchor post and one 25-ft. section of rail element.
- 4.3. **Transitions.** Transitions for rail connection will be measured by each transition.
- 4.4. **Short Radius.** Measurement will be by the foot to the nearest whole foot along the face of the rail in place, from beginning of radius (first CRT post) to the end of radius.
- 4.5. **Driveway Terminal Anchor Section.** Measurement will be by each section, complete in place, consisting of a driveway terminal anchor post and one 6-ft. section of rail element.
- 4.6. **Downstream Anchor Terminal.** Measurement will be by each section, complete in place, consisting of one W-Beam end section, 2 downstream anchor posts, and one rail section.
- 4.7. **Long Span System.** Measurement will be by the foot of fence. Fence will be measured on the face of the rail, in place, between the first CRT and last CRT posts in the system.

5. PAYMENT

The work performed and material furnished in accordance with this Item and measured as provided under "Measurement" will be paid at the unit price bid for "Metal W-Beam Guard Fence" of the post type specified; "Metal Thrie Beam Guard Fence" of the post type specified; "Terminal Anchor Section"; "Metal Beam Guard Fence Transition" of the type specified; "Metal W-Beam Guard Fence Adjustment"; "Metal Thrie Beam Guard Fence Adjustment"; "Terminal Anchor Section Adjustment"; "Transition Adjustment"; "Short Radius"; "Driveway Terminal Anchor Section"; "Downstream Anchor Terminal"; or "Metal Beam Guard Fence (Long Span System)." When weathering steel is required, Type IV will be specified.

Samples furnished to the Department for testing purposes, special backfill materials, and concrete curbs will not be paid directly but are subsidiary to this Item.

- 5.1. **Guard Fence.** The price bid for “Metal W-Beam Guard Fence” or “Metal Thrie Beam Guard Fence” is full compensation for materials, hauling, erection, setting posts in concrete, blocks, driving posts, excavating, backfilling, equipment, labor, tools, and incidentals.
- 5.2. **Terminal Anchor Section.** When a separate bid item is specified, the price bid for “Terminal Anchor Section” is full compensation for furnishing the rail element, anchor assembly, terminal anchor post, and foundations; installing the rail element anchor assembly and the terminal anchor post and foundations; excavation and backfilling; and equipment, labor, tools, and incidentals.
- 5.3. **Transition.** The price bid for “Metal Beam Guard Fence Transition” is full compensation for furnishing nested sections of Thrie Beam; nested sections of W-Beam; Thrie Beam to W-Beam transitional rail piece, posts, concrete, curb, and connections to W-Beam guard fence and bridge rails; Thrie Beam terminal connectors; excavation and backfilling; and equipment, labor, tools, and incidentals.
- 5.4. **Guardrail Adjustment.** The price bid for “Metal W-Beam Guard Fence Adjustment,” “Metal Thrie Beam Guard Fence Adjustment,” “Terminal Anchor Section Adjustment,” and “Transition Adjustment” is full compensation for furnishing materials not supplied by the Department, drilling holes in posts, hauling, erection, blocks, excavation, backfill, cleaning, salvaging materials, setting rail element anchor assembly and terminal anchor post, removal of rail element, concrete, curb, equipment, labor, tools, and incidentals.
- 5.5. **Short Radius.** The price bid for “Short Radius” is full compensation for furnishing special rail fabricated metal beam guard fence, CRT posts, steel posts, sand barrels, end terminal, cable anchor, materials, hauling, erection, blocks, driving posts, excavating, backfilling, equipment, labor, tools, and incidentals.
- 5.6. **Driveway Terminal Anchor Section.** The price bid for “Driveway Terminal Anchor Section” is full compensation for furnishing the rail element, driveway anchor assembly, driveway terminal anchor post, and foundations; installing the rail element anchor assembly and the driveway terminal anchor post and foundations; excavation and backfilling; and equipment, labor, tools, and incidentals.
- 5.7. **Downstream Anchor Terminal.** The price bid for “Downstream Anchor Terminal” is full compensation for furnishing the rail element, W-Beam end section, guardrail anchor bracket, shelf angle bracket, channel strut, downstream anchor posts, breakaway cable terminal (BCT) cable anchor assembly, and foundations; installing the BCT cable anchor assembly and the downstream anchor post and foundations; excavation and backfilling; and equipment, labor, tools, and incidentals.
- 5.8. **Long Span System.** The price bid for “Metal Beam Guard Fence (Long Span System)” is full compensation for furnishing the rail element, CRT posts, materials, hauling, erection, blocks, driving posts, excavating, backfilling, equipment, labor, tools, and incidentals.

Item 542

Removing Metal Beam Guard Fence



1. DESCRIPTION

Remove existing metal beam guard fence and store at locations shown on the plans or as directed.

2. CONSTRUCTION

Remove rail elements in original lengths. Remove fittings from the posts and the metal rail and then pull the posts. Do not mar or damage salvageable materials during removal.

Completely remove posts and any concrete surrounding the posts. Furnish backfill material and backfill the hole with material equal in composition and density to the surrounding soil unless otherwise directed.

Cut off or bend down deadman eyebolts to an elevation at least 1 ft. below the new subgrade elevation and leave in place along with the deadman.

Neatly stack salvaged materials to be retained by the Department at designated sites shown on the plans. Properly dispose of unsalvageable materials in accordance with federal, state, and local regulations. Repair or replace Contractor-damaged salvageable material at the Contractor's expense.

3. MEASUREMENT

This Item will be measured by the foot for "Remove Metal Beam Guard Fence" in its original position. Measurement will be made along the face of the rail, in place, including metal beam guard fence transitions, from center-to-center of end posts and from terminal points shown on the plans.

When "Remove Terminal Anchor Section" is specified as a separate bid item, measurement will be made for each removed section. A terminal anchor section consists of one post, one 25-ft. rail element, and associated hardware.

When "Remove Downstream Anchor Terminal" is specified as a separate bid item, measurement will be made for each removed section. Downstream anchor terminal consists of 2 posts, 1 section, and associated hardware.

4. PAYMENT

The work performed and measured as provided under "Measurement" will be paid at the unit price bid for "Remove Metal Beam Guard Fence," "Remove Terminal Anchor Section," and "Remove Downstream Anchor Terminal." This price will be full compensation for removing materials; loading, hauling, unloading, and storing or disposal; furnishing backfill material; backfilling postholes; and equipment, labor, tools, and incidentals.

Removal of curb associated with the metal beam guard fence transitions will not be paid directly but will be subsidiary to this Item.

Item 543

Cable Barrier System



1. DESCRIPTION

Furnish and install a cable barrier system and cable barrier terminal sections at the locations shown on the plans.

2. MATERIALS

Furnish a new cable barrier system and cable barrier terminal sections in accordance with the details shown on the plans and on the manufacturer's shop drawings, or equal as approved. Cable barrier systems approved for use have passed NCHRP Report 350 or MASH of the test level specified (TL-3, TL-4, etc.) with a maximum deflection of 8 ft.

Furnish pre-stretched cable.

Furnish Class A concrete in accordance with Item 421, "Hydraulic Cement Concrete."

Furnish delineators as shown on the plans and in accordance with Item 658, "Delineator and Object Marker Assemblies."

3. CONSTRUCTION

Install cable barrier system in accordance with the details, dimensions, and requirements shown on the plans and manufacturer's recommendations. Install cable barrier terminal sections in accordance with the details shown on the plans and manufacturer's recommendations.

Place posts into steel sleeves in a concrete foundation unless otherwise shown on the plans. Locate terminal sections at locations as shown on the plans. Repair or replace damaged parts immediately. Provide an installation and repair manual specific to the cable barrier system and cable barrier terminal sections.

Locate barrier delineators at a maximum spacing of 100 ft. and according to TMUTCD or as shown on the plans. Install barrier delineators in accordance with manufacturer's recommendations.

3.1. **Training.** Provide training as specified by the Department.

4. MEASUREMENT

This Item will be measured by the foot of cable barrier system and by each cable barrier terminal section installed.

5. PAYMENT

The work performed and the materials furnished in accordance with this Item and measured as provided under "Measurement" will be paid for at the unit price bid for "Cable Barrier System" of the test level specified (TL-3, TL-4, etc.), "Cable Barrier System" of the test level specified (TL-3, TL-4, etc.) and post spacing specified, and "Cable Barrier Terminal Section" of the test level specified (TL-3, TL-4, etc.). This price is full compensation for furnishing cable barrier system, cable barrier terminal section, concrete, delineators, equipment, labor, tools, and incidentals.

Delineators will not be measured or paid for directly but will be considered subsidiary to this Item.

Item 544

Guardrail End Treatments



1. DESCRIPTION

Furnish and install, move, or remove guardrail end treatments.

2. MATERIALS

Furnish new materials from the Department's MPL of rail element manufacturers. Obtain materials at the location shown on the plans when furnished by the Department.

3. CONSTRUCTION

Install guardrail end treatments in accordance with manufacturer's assembly and installation requirements and the details shown on the plans. Provide the Engineer with manufacturer's installation and repair manuals specific to the guardrail end treatment.

Move or remove guardrail end treatments in accordance with the plans and as directed. Deliver salvageable materials in accordance with the plans or as directed. Dispose of unsalvageable materials in accordance with federal, state, and local regulations.

4. MEASUREMENT

This Item will be measured by each guardrail end treatment.

5. PAYMENT

The work performed and the materials furnished in accordance with this Item and measured as provided for under "Measurement" will be paid for at the unit price bid for "Guardrail End Treatment (Install)" of the post and type specified where applicable, "Guardrail End Treatment (Move and Reset)," or "Guardrail End Treatment (Remove)." This price is full compensation for foundations, materials, stockpiling, disposal of unsalvageable materials, equipment, labor, tools, and incidentals.

Payment for "Guardrail End Treatment (Move and Reset)" will include each guardrail end treatment removed from a stockpile or from an existing location and reset in a new location as detailed on the plans or as directed.

Payment for "Guardrail End Treatment (Remove)" will include each guardrail end treatment removed from an existing location and stockpiled at the location designated on the plans, disposed, or as otherwise directed.

Item 545

Crash Cushion Attenuators



1. DESCRIPTION

Furnish and install, move and reset, or remove crash cushion attenuators.

2. MATERIALS

- 2.1. **Crash Cushion Attenuators.** Furnish new crash cushion attenuators in accordance with the details shown on the plans and on the manufacturer's shop drawings. Obtain crash cushion attenuators at the location shown on the plans when furnished by the Department.
- 2.2. **Concrete.** Furnish Class S concrete for pads that meets Item 421, "Hydraulic Cement Concrete."

3. CONSTRUCTION

Perform the following as shown on the plans:

- 3.1. **Installation.** Assemble and install crash cushion attenuators in accordance with the details shown on the plans and manufacturer recommendations. Obtain assembly and installation information for the crash cushion attenuators from the manufacturer and provide the Engineer with an installation and repair manual specific to the crash cushion attenuators.
- 3.2. **Moving and Resetting.** Remove crash cushion attenuators from a stockpile or from an existing location and reset in a new location as shown on the plans or as directed. Install crash cushion attenuators in accordance with pertinent standards and manufacturer recommendations. Provide additional materials to complete the installation as needed. Dispose of unsalvageable materials in accordance with federal, state, and local regulations.
- 3.3. **Removal.** Remove crash cushion attenuators from an existing location and stockpile in the area designated on the plans, as directed, or dispose. Clean and repair salvageable units before inspection and return them to the Department. Dispose of unsalvageable materials in accordance with federal, state, and local regulations.

4. MEASUREMENT

This Item will be measured by each crash cushion attenuator.

5. PAYMENT

The work performed and the materials furnished in accordance with this Item and measured as provided for under "Measurement" will be paid for at the unit price bid for "Crash Cushion Attenuator (Furnish and Install, Designated Source, Move and Reset, Stockpile, or Remove)" of the category, width (N or W), and test level. This price is full compensation for foundations; materials, stockpiling, moving and removing, hauling, installing and resetting, disposal of unsalvageable materials, equipment, labor, tools, and incidentals.

- 5.1. **Furnish and Install.** This price is full compensation for furnishing and installing crash cushion attenuator.
- 5.2. **Designated Source.** This price is full compensation for delivering and installing Department-furnished crash cushion attenuator from a designated source.

- 5.3. **Move and Reset.** This price is full compensation for moving crash cushion attenuator installations on the project from one location to another (including disassembly and reassembly costs), moving crash cushion attenuator from an installation on the project to a temporary storage area (including disassembly costs), and moving crash cushion attenuator from a temporary storage area to an installation site on the project (including assembly costs).
- 5.4. **Stockpile.** This price is full compensation for removing crash cushion attenuator from the project and delivering to the Department stockpile area shown on the plans or as directed.
- 5.5. **Remove.** This price is full compensation for removing crash cushion attenuator from the project and retained by the Contractor.

Item 550

Chain Link Fence



1. DESCRIPTION

Furnish, install, remove, repair, or replace chain link fence and gates.

2. MATERIALS

Furnish certification from the chain link fence materials manufacturer stating that all fencing materials comply with the requirements of this Item before installation of the fence. Use only new materials.

2.1. **General.** Furnish materials in accordance with the following:

- Item 421, "Hydraulic Cement Concrete," Class B
- Item 445, "Galvanizing"

2.2. **Wire Fabric.** Provide wire fabric with:

- 9 gauge (0.148 in. diameter) steel wire with a minimum breaking strength of 1,290 lb. meeting ASTM A392 Class I or ASTM A491;
- mesh size of 2 in. \pm 1/8 in. between parallel wires with at least 7 meshes in a vertical dimension of 23 in. along the diagonals of the openings; and
- knuckled selvages at the top and bottom edge of the fabric, unless otherwise shown on the plans.

2.3. **Posts.** Provide posts of the size and weight shown on the plans. Do not provide rerolled or open-seam posts. Use material for all posts meeting ASTM F1043 Group 1A Regular Grade or Group 1C High Strength.

2.4. **Post Caps.** Provide malleable iron post caps designed to exclude all moisture. Furnish barbed wire support arms integral with the post caps if barbed wire is shown on the plans. Furnish post caps with an opening for the top rail if top rail is shown on the plans. Post caps must have a 2-in. skirt.

2.5. **Gates.** Provide gates fabricated from round sections of pipe of the size and weight shown on the plans. Use material for all gate pipes meeting ASTM F1043 Group 1A Regular Grade or Group 1C High Strength. For each gate, include:

- corner and tee fittings of malleable iron or pressed steel with means for attaching diagonal bracing members;
- hinges of malleable iron allowing a full 180° swing, easily operated by one person;
- ball-and-socket-type bottom hinges that do not twist or turn from the action of the gate and prevent the closed gate from being lifted off the hinges;
- a positive stop that prevents any portion of the gate from swinging over an adjacent traffic lane;
- malleable iron pulley systems for roll type gate (only when required);
- diagonal braces consisting of 3/8-in. diameter cable with turnbuckles, 2 to each gate frame, and, for vehicle gates, a vertical pipe brace of the size and weight shown on the plans at the center of each gate leaf;
- latches of malleable iron or steel for single gates with a single-fork latch and padlock eye that will keep the gate closed;
- 2 fork latches mounted on a center plunger rod with a padlock eye for double-leaf gates;
- holdbacks for each leaf of vehicular gates, with a semi-automatic holdback catch anchored at least 12 in. into a 12-in. diameter by 24-in. deep concrete footing; and

- a malleable iron center rest, designed to receive the plunger rod anchored as shown on the plans for all double-leaf gates.
- 2.6. **Top Rail.** Use material meeting ASTM F1043 Group 1A or 1C for all top rail pipes. Provide 1.660 in. OD top rail manufactured from Group 1A standard weight (Schedule 40) steel pipe weighing 2.27 lb. per foot or from Group 1C high-strength pipe weighing 1.84 lb. per foot when shown on the plans. Provide pipe in sections at least 18 ft. long joined with outside steel sleeve couplings at least 6 in. long with a minimum wall thickness of 0.70 in. Use couplings designed to allow for expansion of the top rail.
- 2.7. **Tension Wire.** Use 7 gauge (0.177-in.) carbon steel wire with a minimum breaking strength of 1,950 lb. for the bottom edge of all fence fabric, and for the top edge of fence fabric when a top rail is not specified.
- 2.8. **Truss Bracing.** Provide truss bracing as shown on the plans.
- 2.9. **Cables.** Provide 7-wire strand cables manufactured of galvanized annealed steel at least 3/8 in. in diameter.
- 2.10. **Barbed Wire.** Provide 3 strands of twisted 12.5 gauge barbed wire with 2-point, 14 gauge barbs spaced approximately 5 in. apart conforming to ASTM A121 or ASTM A585 when specified on the plans.
- 2.11. **Barbed Wire Support Arms.** Provide support arms at an angle of 45° from vertical, with clips for attaching 3 strands of barbed wire to each support arm and sufficient strength to support a 200-lb. weight applied at the outer strand when barbed wire is specified on the plans.
- 2.12. **Stretcher Bars.** Provide stretcher bars made of flat steel at least 3/16 × 3/4 in. and not more than 2 in. shorter than the fabric height. Provide one stretcher bar for each gate and end post and 2 stretcher bars for each corner and pull post.
- 2.13. **Grounds.** Provide copper-clad steel rods 8 ft. long with a minimum diameter of 5/8 in., or other UL-listed ground rods.
- 2.14. **Miscellaneous Fittings and Fasteners.** Furnish enough fittings and fasteners to erect all fencing materials in a proper manner. Furnish fittings for posts from pressed or rolled steel, forged steel, malleable iron or wrought iron of good commercial quality spaced as shown on the plans.
- 2.15. **Coatings.** Hot-dip galvanize all materials unless specified otherwise in this Item or on the plans. Fabric, tension wire, and barbed wire may be aluminum-coated or alloy-coated if approved. Additionally coat all material except bolts, nuts, washers, and pipe material with thermally fused polyvinyl chloride (PVC) in accordance with ASTM F668, Class 2b, meeting the specified color when shown on the plans.
 - 2.15.1. **Fabric.**
 - 2.15.1.1. **Galvanizing.** Hot-dip galvanize in accordance with ASTM A392, Class I.
 - 2.15.1.2. **Aluminum Coating.** Aluminum-coat in accordance with ASTM A491.
 - 2.15.1.3. **Alloy Coating.** Coat with zinc-5% aluminum-mischmetal alloy (Zn-5A1-MM) in accordance with ASTM F1345, Class I.
 - 2.15.2. **Posts, Braces, and Gates.**
 - 2.15.2.1. **Standard Weight (Schedule 40) Pipe.** Hot-dip galvanize inside and outside according to ASTM F1043 (1.8 oz./sq. ft. galvanized zinc weight).
 - 2.15.2.2. **High Strength Pipe.** Hot-dip galvanize before or after forming pipe according to ASTM F1043 Group 1C and as follows:
 - Outside—minimum 0.9 oz./sq. ft. galvanized zinc weight with a verifiable polymer overcoat.

Penetrate solid rock by at least 12 in. (18 in. for end, corner, gate, and pull posts) or to plan depth where the rock is encountered before reaching plan depth. Drill holes in the solid rock with a diameter at least 1 in. greater than the outside diameter of the post.

Fill the hole in the solid rock with grout consisting of 1 part hydraulic cement and 3 parts clean, well-graded sand after the posts are set and plumbed. If desired, other grouting materials may be used only if approved. Thoroughly work the grout into the hole, leaving no voids. Construct concrete footings from the solid rock to the top of the ground.

- 3.2.3. **Gate Posts.** Align the tops of all gate frames with the fencing top tension wire or top rail. Provide vehicular gates that are greater in overall height than the adjacent fencing by the height necessary to extend to within 2 in. of the pavement between the curbs if curbs are shown on the plans.

- 3.2.4. **Concrete Footings.** Center posts in their footings. Place concrete and compact by tamping or other approved methods. Machine mix all batches of concrete over 1/2 cu. yd. Hand mixing concrete is allowed on batches under 1/2 cu. yd.

Use forms for footings where the ground cannot be satisfactorily excavated to neat lines. Crown the concrete or grout (for solid rock) to carry water from the post. Keep the forms in place for at least 24 hr. Backfill the footing with moistened material as soon as each form is removed, and thoroughly tamp. Cover concrete with at least 4 in. of loose moist material, free of clods and gravel, immediately after placing concrete. No other curing is required.

Spread all excess excavated and loose material used for curing neatly and uniformly. Remove excess concrete and other construction debris from the site.

- 3.3. **Erection of Fabric.** Place the fabric with the cables drawn taut with the turnbuckles after all posts have been permanently positioned and anchorages firmly set. Secure one end and apply enough tension to the other end to remove all slack before making attachments. Cut the fabric and independently attach each span at all corner posts and pull posts unless otherwise shown on the plans.

Follow the finished contour of the site with the bottom edge of fabric located approximately 2 in. above the grade. Grade uneven areas so the maximum distance between the bottom of fabric and ground is 6 in. or less.

Fasten fabric at 12 in. intervals to the top and bottom tension wires between posts. Fasten the fabric in the same manner when top rail is shown on the plans. Fasten the fabric on gate frames to the top and bottom of the frame at 12 in. intervals. Use steel wire fabric ties of 9 gauge steel or larger. Fasten fabric to terminal posts by steel stretcher bars and stretcher bar bands fitted with carriage bolts and nuts of the size and spacing shown on the plans. Use stretcher bars to fasten end posts, pull posts, corner posts, and gateposts with stretcher bar bands at intervals of no more than 15 in. Attach stretcher bars to terminal posts with 1 × 1/8 in. flat steel bands with 3/8-in. carriage bolts at intervals up to 15 in.

- 3.4. **Electrical Grounds.** Provide at least one electrical ground for each 1,000 ft. of fence, located near the center of the run. Provide additional grounds directly under the point where power lines pass over the fence.

Vertically drive or drill in the grounding rod until the top of the rod is approximately 6 in. below the top of the ground. Connect a No. 6 solid copper conductor to the rod and to the fence by a UL-listed method so that each element of the fence is grounded.

- 3.5. **Repair of Coatings.** Repair damaged zinc coating in accordance with Section 445.3.5., "Repairs."

4. MEASUREMENT

Chain link fence will be measured by the foot of fence installed, repaired, replaced, or removed, measured at the bottom of the fabric along the centerline of the fence from center to center of posts, excluding gates.

Gates will be measured as each gate installed, repaired, replaced, or removed.

5. PAYMENT

The work performed and materials furnished in accordance with this Item and measured as provided under "Measurement" will be paid for at the unit price bid for "Chain Link Fence (Install)" or "Chain Link Fence (Repair)" of the height specified or "Chain Link Fence (Remove)" and "Gate (Install)" or "Gate (Repair)" of the type, height, and width of opening specified or "Gate (Remove)." Clearing and grading for fencing and gates will not be paid for directly but is subsidiary to this Item.

- 5.1. **Chain Link Fence (Install).** This price is full compensation for furnishing and installing fencing, except gates; cleaning, grading, and backfilling; removing and disposing of surplus material; and equipment, labor, tools, and incidentals.
- 5.2. **Chain Link Fence (Repair).** This price is full compensation for furnishing materials; repairing or replacing fencing, except gates; cleaning, grading, and backfilling; removing and disposing of surplus or damaged material; and equipment, labor, tools, and incidentals.
- 5.3. **Chain Link Fence (Remove).** This price is full compensation for removing all fencing, except gates; cleaning, grading, and backfilling; removing and disposing of surplus material; and equipment, labor, tools, and incidentals.
- 5.4. **Gate (Install).** This price is full compensation for installing gate and for providing materials, center anchorages, equipment, labor, tools, and incidentals.
- 5.5. **Gate (Repair).** This price is full compensation for repairing or replacing gate and for furnishing materials; removing and disposing of damaged materials; and equipment, labor, tools, and incidentals.
- 5.6. **Gate (Remove).** This price is full compensation for removing gate and for materials, equipment, labor, tools, and incidentals.

Item 552

Wire Fence



1. DESCRIPTION

Furnish and construct fence of barbed wire or a combination of woven fence fabric and barbed wire, supported on metal or wood posts.

2. MATERIALS

Furnish materials in accordance with details shown on the plans and with the requirements of this Article.

- 2.1. **Metal Posts and Braces.** Furnish steel pipe in accordance with ASTM A53 if used for posts and braces. Use steel that meets ASTM A702 for T-posts. Use only new steel. Do not use rerolled or open-seam material. Furnish galvanized steel sections in accordance with Item 445, "Galvanizing." Use an approved anticorrosive coating when painting is specified. Spot-coat damaged areas with the same paint color after installation of painted posts and braces. Use paint with at least the same anticorrosive properties as the original paint. Use the size, weight, and area of posts, braces, and anchor plates shown on the plans.
- 2.2. **Wood Posts and Braces.**
- 2.2.1. **Untreated Wood.** Provide cedar or juniper timber.
- 2.2.2. **Treated Wood.** Provide pine timber treated in accordance with Item 492, "Timber Preservative and Treatment." Remove outer bark and all inner cambium bark on treated posts; occasional strips of bark may remain if not over 1/2 in. wide or over 3 in. long.
- Use sound timber that is free from decay, shakes, splits, or other defects that would weaken the posts or braces or otherwise make them structurally unsuitable for the purposes intended. Knots that are sound, tight, trimmed flush, and not in clusters will be allowed, provided they do not exceed 1/3 of the small diameter or the least dimension of the posts and braces. Remove spurs and splinters, cutting the ends square.
- 2.3. **Gates and Gateposts.** Furnish materials to the dimensions shown on the plans or as directed.
- 2.4. **Barbed Wire.** Furnish barbed wire in accordance with ASTM A121, Class 1. Use barbed wire consisting of 2 strands of 12-1/2 gauge wire, twisted with 2-point 14 gauge barbs spaced no more than 5 in. apart, or other barbed wire as directed.
- 2.5. **Wire Mesh.** Furnish wire mesh fabric in accordance with ASTM A116, Class 1 to the height and design shown on the plans. Use at least 10 gauge wire for the top and bottom wires and at least 12-1/2 gauge wire for the intermediate wires and vertical stays.
- 2.6. **Miscellaneous.** Furnish galvanized bolts, nuts, washers, braces, straps, and suitable devices for holding barbed wire and wire mesh firmly to metal posts. Use material of good commercial quality and design. Provide galvanized staples at least 1-1/2 in. long.

3. CONSTRUCTION

Space fence posts as shown on the plans. Set fence posts plumb and firm at the intervals, depth, and grade shown on the plans. Brace corner and pull posts in 2 directions. Brace end posts and gateposts in one direction. Install a corner post where the alignment changes 30° or more. Brace the angle post to the adjacent line posts with diagonal tension wires at alignment angles between 15° and 30°.

Snub or guy fencing at the critical point of grade depressions where stresses tend to pull posts out of the ground with a double 9 gauge galvanized wire. Connect the wire to the top horizontal line of the barbed wire or to the top and bottom wire or wire mesh fabric, and to a deadman weighing at least 100 lb. Stretch the fence before guying and snubbing.

Install corner, end, or angle post assembly before stretching the wire between posts. Connect existing cross fences to the new fences and corner posts at junctions with existing fences. Fasten to posts using galvanized ties or staples while drawing barbed wire and wire fabric taut, or as shown on the plans. Install pull post assemblies at 500-ft. intervals for steel posts and at 1,000-ft. intervals for wood posts. Metal line posts may be driven provided driving does not damage the posts. Metal corners, ends, pull posts, and braces must be set in concrete footings crowned at the top to shed water. Thoroughly tamp backfill in 4-in. layers. Notch timber posts as shown on the plans.

4. MEASUREMENT

Fencing will be measured by the foot of wire fence, excluding gates. Gates will be measured as each gate.

5. PAYMENT

The work performed and materials furnished in accordance with this Item and measured as provided under "Measurement" will be paid for at the unit price bid for "Wire Fence" or "Gate" of the type specified. This price is full compensation for furnishing, preparing, hauling, and installing fence and gate materials; excavation, backfilling, and disposal of surplus material; removal and trimming of brush and tree limbs; and equipment, labor, tools, and incidentals.

Removal of existing fence and gates will not be paid for directly but will be subsidiary to pertinent Items unless otherwise shown on the plans.

Item 556

Pipe Underdrains



1. DESCRIPTION

Install pipe underdrains.

2. MATERIALS

2.1. **Pipe.** Furnish the types and sizes of pipe specified on the plans. Use only one type of pipe for any underdrain system on the project. Use perforated pipe in areas to be drained, and use non-perforated pipe between the perforated pipe and the outfall.

2.1.1. **Type 1.** Corrugated steel pipe (CSP) conforming to any type specified in AASHTO M 36, fabricated from corrugated galvanized sheet.

2.1.2. **Type 2.** Corrugated aluminum pipe conforming to AASHTO M 196, Type I or IA, fabricated from corrugated sheet.

2.1.3. **Type 3.** Bituminous-coated corrugated steel pipe conforming to the requirements of Type 1 and uniformly coated inside and out with a minimum thickness of 0.05 in. of bituminous material meeting the requirements of Table 1 when tested in accordance with ASTM A849, Material Class A or Material Class PA.

Table 1
Requirements of Bituminous Material

Test	Requirements
Solubility, % by wt., in trichloroethylene	99.5 Min
Brittleness	Pass
Flow, in.	0.25 Max

2.1.4. **Type 4.** Bituminous-coated corrugated aluminum pipe conforming to the requirement of Type 2 and uniformly coated inside and out with a minimum thickness of 0.05 in. of bituminous material meeting the requirements of Table 1 when tested in accordance with ASTM A849, Material Class A or Material Class PA.

2.1.5. **Type 5.** Acrylonitrile-butadiene-styrene (ABS) pipe conforming to ASTM D2751, SDR-35. Perforations must meet the requirements of AASHTO M 278.

2.1.6. **Type 6.** Corrugated polyethylene plastic tubing conforming to AASHTO M 252.

2.1.7. **Type 7.** Corrugated polyvinyl chloride (PVC) pipe conforming to ASTM F949.

2.1.8. **Type 8.** Smooth-wall PVC pipe conforming to AASHTO M 278, Class PS 46.

2.1.9. **Type 9.** As shown on the plans.

2.2. **Filter Material.** Furnish hard, durable, and clean sand, gravel, crushed stone, or crushed shell meeting the gradation by percent weight specified in Table 2 unless otherwise shown on the plans. Filter material must be free of clay balls or other organic or deleterious matter as determined by Tex-413-A. Do not furnish crushed limestone unless shown on the plans. Use only one type of filter material for any underdrain system on a project.

Table 2
Percent Retained on Sieve (Tex-401-A)

Sieve Size	Type A	Type B	Type C	Type D
1-1/2"	–	–	0–10	
3/4"	–	0–10	20–40	
3/8"	–	15–35	–	–
#4	0–10	35–55	40–60	0–5
#8				0–20
#16				15–50
#20	35–65 ¹	35–65 ¹	35–65 ¹	
#30				40–75
#50	75–100 ¹	75–100 ¹	75–100 ¹	70–90
#100				90–100

1. Of the portion finer than No. 4 sieve.

Loss by decantation as determined by Tex-406-A must not exceed 1% of the material retained on a No. 4 sieve or 4% of the material passing a No. 4 sieve. Use Type B or Type C filter material around the underdrains unless otherwise shown on the plans. Do not place Type A or Type D filter material within 6 in. of perforations.

- 2.3. **Filter Fabric.** Meet DMS-6200, "Filter Fabric," Type 1.
- 2.4. **Riprap.** Provide concrete riprap in accordance with Item 432, "Riprap," when required.

3. CONSTRUCTION

Begin excavation of the trench at the outfall and proceed toward its upper end, following the lines and grades shown on the plans or as directed. Hold the minimum horizontal limits of excavation for filter material to the dimensions shown in Table 3 or as shown on the plans.

Table 3
Minimum Horizontal Limits of Excavation for Filler Material

Depth of Trench (ft.)	Distance Outside Neat Lines of Pipe Underdrains (ft.)
0 to 6	1.00
Over 6 to 10	1.50
Over 10 to 15	2.00
Over 15	2.50

Place filter fabric in the bottom and sides of the trench in areas to be drained before placing pipe or filter material, as shown in Figure 1. Provide enough width of fabric to overlap on top of the filter material. Center perforated pipe in the excavated ditch with the perforations below the horizontal axis. Join the pipe with appropriate couplers if required. Join plastic pipe in accordance with the manufacturer's recommendations. Do not use tarpaper strips. Obtain approval for pipe placement before placing filter material.

Place filter material at least 12 in. above the bottom of the pipe or as shown on the plans. Do not allow filter material to displace the pipe.

Lap filter fabric over the top of the filter material after placing pipe and filter material according to the manufacturer's recommendation or as shown on the plans.

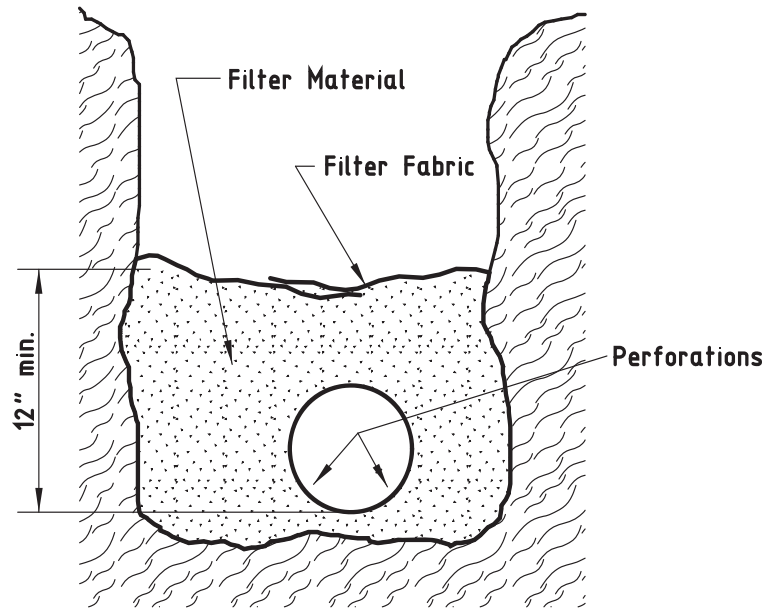

Trench
Figure 1
Installation Process

Install non-perforated pipe sections between the perforated pipe and the outfall. The sections of non-perforated pipe do not require filter fabric or filter material.

Place approved plugs in the upper ends of all pipe. Cover exposed outfall ends with 1/2-in. galvanized hardware cloth as directed. Provide Class B concrete riprap, when required, in accordance with Item 432, "Riprap," and details shown on the plans. Place the riprap to the contour and grade of the embankment slope. Cut the pipe to the slope of the riprap.

Backfill the remainder of the trench with suitable material in layers not to exceed 6 in.

4. MEASUREMENT

This Item will be measured by the foot along the top of the pipe and will include the length of elbows, Y's, T's, and other branches.

5. PAYMENT

The work performed and material furnished in accordance with this Item and measured as provided under "Measurement" will be paid for at the unit price bid for "Pipe Underdrains" of the pipe type and size specified. This price is full compensation for pipe, couplers, plugs, screens, filter material, filter fabric, riprap, excavation, backfill, equipment, labor, materials, tools, and incidentals.

Protection methods for excavations deeper than 5 ft. will be measured and paid for in accordance with Item 402, "Trench Excavation Protection."

Item 560

Mailbox Assemblies



1. DESCRIPTION

Install, remove, temporarily relocate, or replace mailbox assemblies of the type specified.

2. MATERIAL

Furnish mailbox assemblies in accordance with the plans. An assembly does not include the mailbox unless shown otherwise on the plans. Provide new mailbox assemblies for permanent installations.

3. CONSTRUCTION

Temporarily relocate mailbox assemblies as shown on the plans or as directed. Furnish and install approved mailbox assemblies and mount mailboxes on those assemblies. Maintain mailbox assemblies in a serviceable condition. Furnish and install additional mailbox assemblies as directed. Relocate mailbox and assemblies to permanent locations upon completion of construction work.

4. MEASUREMENT

This Item will be measured by each permanent mailbox assembly installed.

5. PAYMENT

The work performed, materials furnished, and measured according to "Measurement" will be paid at the unit price bid for "Mailbox Installation (Single)," of the type specified; "Mailbox Installation (Double)," of the type specified; or "Mailbox Installation (Multiple)," of the type specified. This price is full compensation for installing mailboxes and reflectors in permanent locations, materials, equipment, labor, tools, and incidentals. Removing existing or installing and moving temporary mailbox assemblies will not be paid directly but will be subsidiary to pertinent Items.

Item 585

Ride Quality for Pavement Surfaces



1. DESCRIPTION

Measure and evaluate the ride quality of pavement surfaces.

2. EQUIPMENT

2.1. **Surface Test Type A.** Provide a 10-ft. straightedge or where allowed, a high-speed or lightweight inertial profiler, certified at the Texas A&M Transportation Institute.

2.2. **Surface Test Type B.** Provide a high-speed or lightweight inertial profiler, certified at the Texas A&M Transportation Institute. Provide equipment certification documentation. Display a current decal on the equipment indicating the certification expiration date.

Use a certified profiler operator from the Department's MPL. When requested, furnish documentation for the person certified to operate the profiler.

2.3. **Diamond Grinding Equipment.** Provide self-propelled powered grinding equipment specifically designed to smooth and texture pavements using circular diamond blades when grinding is required. Provide equipment with automatic grade control capable of grinding at least 3 ft. of width longitudinally in each pass without damaging the pavement.

3. WORK METHODS

Measure and evaluate profiles using Surface Test Types A and B on surfaces as described below unless otherwise shown on the plans.

3.1. **Transverse Profile.** Measure the transverse profile of the finished riding surface in accordance with Surface Test Type A.

3.2. **Longitudinal Profile.** Measure the longitudinal profile of the surface, including horizontal curves.

3.2.1. **Travel Lanes.** Unless otherwise shown on the plans, use Surface Test Type B on the final riding surface of all travel lanes except as follows:

3.2.1.1. **Service Roads and Ramps.** Use Surface Test Type A on service roads and ramps unless Surface Test Type B is shown on the plans.

3.2.1.2. **Short Projects.** Use Surface Test Type A when project pavement length is less than 2,500 ft. unless otherwise shown on the plans.

3.2.1.3. **Bridge Structures.** Measure the profile in accordance with the pertinent item or use Surface Test Type A for span type bridge structures, approach slabs, and the 100 ft. leading into and away from such structures.

3.2.1.4. **Leave-Out Sections.** Use Surface Test Type A for leave-out sections and areas between leave-out sections that are less than 100 ft.

3.2.1.5. **Ends.** Use Surface Test Type A on the first and last 100 ft. of the project pavement length.

- 3.2.2. **Shoulders and Other Areas.** Use Surface Test Type A for shoulders and all other areas including intermediate pavement layers.
- 3.3. **Profile Measurements.** Measure the finished surface in accordance with Surface Test Type A or B in accordance with Section 585.3.1., "Transverse Profile," Section 585.3.2., "Longitudinal Profile," and the plans.
- 3.3.1. **Surface Test Type A.** Test the surface with a 10-ft. straightedge as directed. Use an inertial profiler to measure the surface when allowed. The Engineer will use Department software to evaluate the surface.
- 3.3.2. **Surface Test Type B.**
- 3.3.2.1. **QC Testing.** Perform QC tests on a daily basis throughout the duration of the project. Use a 10-ft. straightedge, inertial profiler, profilograph, or any other means to perform QC tests.
- 3.3.2.2. **QA Testing.** Perform QA tests using either a high-speed or lightweight inertial profiler. Coordinate with and obtain authorization from the Engineer before starting QA testing. Perform QA tests on the finished surface of the completed project or at the completion of a major stage of construction, as approved. Perform QA tests within 7 days after receiving authorization.
- The Engineer may require QA testing to be performed at times of off-peak traffic flow. Operate the inertial profiler in a manner that does not unduly disrupt traffic flow as directed. When using a lightweight inertial profiler to measure a surface that is open to traffic, use a moving traffic control plan in accordance with Part 6 of the TMUTCD and the plans.
- In accordance with Tex-1001-S, operate the inertial profiler and deliver test results within 24 hr. of testing. Provide all profile measurements in electronic data files using the format specified in Tex-1001-S.
- 3.3.2.2.1. **Verification Testing.** The Engineer may perform ride quality verification testing within 10 working days after the Contractor's QA testing is complete for the project or major stage of construction. When the Department's profiler produces an overall average international roughness index (IRI) value over 3.0 in. per mile higher than the value calculated using Contractor data, the Engineer will decide whether to accept the Contractor's data, use the Department's data, use an average of both parties' data, or request a referee test. Referee testing is mandatory if the difference is greater than 6.0 in. per mile.
- 3.3.2.2.2. **Referee Testing.** The Construction Division will conduct referee testing, and the results are final. The Construction Division may require recertification for the Contractor's or Department's inertial profiler.
- 3.4. **Acceptance Plan and Payment Adjustments.** The Engineer will evaluate profiles for determining acceptance, payment adjustment, and corrective action.
- 3.4.1. **Surface Test Type A.** Use diamond grinding or other approved work methods to correct surface areas that have more than 1/8-in. variation between any 2 contacts on a 10-ft. straightedge. For asphalt concrete pavements, fog seal the aggregate exposed from diamond grinding. Following corrective action, retest the area to verify compliance with this Item.
- 3.4.2. **Surface Test Type B.** The Engineer will use the QA test results to determine payment adjustments for ride quality using Department software. IRI values will be calculated using the average of both wheel paths. When taking corrective actions to improve a deficient 0.1-mi. section, payment adjustments will be based on the data obtained from reprofiling the corrected area.
- 3.4.2.1. **IRI Payment Adjustment for 0.1-mi. Sections.** Unless payment adjustment Schedule 1 or 2 is shown on the plans, Schedule 3 from Table 1 and Table 2 will be used to determine the level of payment adjustment for each 0.1-mi. section on the project.

No payment adjustment will be paid for any 0.1-mi. section that contains localized roughness.

- 3.4.2.2. **IRI Deficient 0.1-mi. Sections.** When payment adjustment Schedule 1 or 2 is specified, correct any 0.1-mi. section with an average IRI over 95.0 in. per mile. Correct the deficient section to an IRI of 65 in. per mile or less when Schedule 1 is specified or correct to an IRI of 75 in. per mile or less when Schedule 2 is specified. No corrective action is required for Schedule 3. After making corrections, reprofile the pavement section to verify that corrections have produced the required improvements.

The associated payment adjustment shown in Table 1 applies when successful corrective action improves the IRI of a deficient 0.1-mi. section.

If corrective action does not produce the required improvement, the Engineer may require:

- continued corrective action, or
- apply the pertinent payment adjustment shown in Table 2 if the reprofiled IRI is greater than 65 in. per mile.

- 3.4.2.2.1. **Corrective Action.** Use diamond grinding or other approved work methods to correct any deficient 0.1-mi. section. For asphalt concrete pavements, fog seal the aggregate exposed from diamond grinding or other approved work methods allowed.

- 3.4.2.3. **Localized Roughness.** Measure localized roughness using an inertial profiler in accordance with Tex-1001-S. The Engineer will determine areas of localized roughness using the individual profile from each wheel path.

Use a 10-ft. straightedge, when allowed, to locate areas that have more than 1/8-in. variation between any 2 contacts on the straightedge when Schedule 3 is specified.

The Engineer may waive localized roughness requirements for deficiencies resulting from manholes or other similar appurtenances near the wheel paths.

- 3.4.2.3.1. **Corrective Action.** Use diamond grinding or other approved work methods to correct localized roughness. For asphalt concrete pavements, fog seal the aggregate exposed from diamond grinding or other approved work methods allowed. Reprofile the corrected area, and provide results that show the corrective action was successful. If the corrective action is not successful, the Engineer will require continued corrective action or apply a localized roughness payment adjustment.

- 3.4.2.3.2. **Localized Roughness Payment Adjustment.** Instead of continued corrective action, the Engineer may assess a payment adjustment for each occurrence of localized roughness. No more than one payment adjustment will be applied for any 5 ft. of longitudinal distance. For Schedule 1, a localized roughness payment adjustment of \$500 per occurrence will be applied. For Schedule 2, a localized roughness payment adjustment of \$250 per occurrence will be applied. For Schedule 3, a localized roughness payment adjustment will not be applied.

Localized roughness payment adjustments will be evaluated within 0.1-mi. sections and applied unless the IRI deficient 0.1-mi. section payment adjustment is greater. When the IRI deficient payment adjustment is greater, the payment adjustment in Table 2 will be applied.

4. MEASUREMENT AND PAYMENT

The work performed, materials furnished, certification and recertification, traffic control for all testing, materials and work needed for corrective action, equipment, labor, tools, and incidentals will not be measured or paid for directly but will be subsidiary to pertinent Items. Sections shorter than 0.1 mi. and longer than 50 ft. will be prorated in accordance with Tex-1001-S.

Table 1
Payment Adjustments for Ride Quality

Average IRI for each 0.10 mi. of Traffic Lane (in./mi.)	Payment Adjustment \$/0.10 mi. of Traffic Lane	
	Schedule 1 and Schedule 2	Schedule 3
≤ 30	600	300
31	580	290
32	560	280
33	540	270
34	520	260
35	500	250
36	480	240
37	460	230
38	440	220
39	420	210
40	400	200
41	380	190
42	360	180
43	340	170
44	320	160
45	300	150
46	280	140
47	260	130
48	240	120
49	220	110
50	200	100
51	180	90
52	160	80
53	140	70
54	120	60
55	100	50
56	80	40
57	60	30
58	40	20
59	20	10
60 to 65	0	0

Table 2
Payment Adjustments for Ride Quality

Average IRI for each 0.10 mi. of Traffic Lane (in./mi.)	Payment Adjustment \$/0.10 mi. of Traffic Lane	
	Schedule 1	Schedule 2
66	-20	0
67	-40	0
68	-60	0
69	-80	0
70	-100	0
71	-120	0
72	-140	0
73	-160	0
74	-180	0
75	-200	0
76	-220	-20
77	-240	-40
78	-260	-60
79	-280	-80
80	-300	-100
81	-320	-120
82	-340	-140
83	-360	-160
84	-380	-180
85	-400	-200
86	-420	-220
87	-440	-240
88	-460	-260
89	-480	-280
90	-500	-300
91	-520	-320
92	-540	-340
93	-560	-360
94	-580	-380
95	-600	-400
> 95	-3,000	

600 Items

Lighting, Signing, Markings, and Signals

This page intentionally left blank

Item 610

Roadway Illumination Assemblies



1. DESCRIPTION

- **Installation.** Furnish, fabricate, and install roadway illumination assemblies.
- **Relocation.** Remove and relocate existing roadway illumination assemblies.
- **Removal.** Remove existing roadway illumination assemblies.
- **Replace Luminaires (Light Fixtures).** Remove and replace existing luminaires.

2. MATERIALS

Provide new materials that comply with the details shown on the plans, the requirements of this Item, and the pertinent requirements of the following Items:

- Item 416, "Drilled Shaft Foundations"
- Item 421, "Hydraulic Cement Concrete"
- Item 441, "Steel Structures"
- Item 442, "Metal for Structures"
- Item 445, "Galvanizing"
- Item 449, "Anchor Bolts"
- Item 616, "Performance Testing of Lighting Systems"
- Item 618, "Conduit"
- Item 620, "Electrical Conductors"

Fabrication plants that produce roadway illumination poles, including luminaire arms, must be approved in accordance with DMS-7380, "Steel Non-Bridge Member Fabrication Plant Qualification." This includes fabricators of aluminum roadway illumination poles and luminaire arms. The Construction Division maintains a list of approved fabrication plants of roadway illumination poles.

Furnish light fixtures from new materials that are in accordance with DMS-11010, "Roadway Illumination Light Fixtures."

Provide prequalified light fixtures from the Department's MPL. When required by the Engineer, notify the Department in writing of selected materials from the MPL intended for use on each project.

Do not provide shop drawings for complete assemblies that are fabricated in accordance with this Item and the details shown on the plans. Electronically submit shop drawings in accordance with Item 441, "Steel Structures," for optional multi-sided steel pole designs; optional aluminum pole designs; and non-standard designs, required when basic wind speeds or pole base mounting heights at the installation locations are in excess of those shown on the Roadway Illumination Pole (RIP) standard. Manufacturers may request that the Department add their submitted shop drawings and design calculations to a pre-approved list of optional and non-standard pole designs, maintained by the Traffic Operations Division.

Hot-dip galvanize fabricated pole sections and associated parts in accordance with Item 445, "Galvanizing." Punch or drill holes in steel parts or members, when allowed, before galvanizing.

When shown on the plans, paint poles in accordance with the plans for uncoated structures and in accordance with Item 445, "Galvanizing" for galvanized structures.

3. CONSTRUCTION

Perform work in accordance with the details shown on the plans and the requirements of this Item. Permanently mark roadway illumination pole base plates, at a visible location when erected, with the fabrication plant's insignia or trademark. Sample fixtures for testing in accordance with Tex-1110-T.

Use established industry and utility safety practices when installing, relocating, or removing poles or luminaires located near overhead or underground utilities. Consult with the appropriate utility company before beginning work.

Prevent scarring or marring of the poles, luminaire arms, and luminaires. Replace damaged components. Repair damaged galvanizing in accordance with Section 445.3.5., "Repairs." Repair damaged painted areas of a roadway illumination assembly in accordance with Item 441, "Steel Structures" or Item 445, "Galvanizing."

Stake, install, and align each roadway illumination assembly as shown on the plans.

The Engineer may shift an assembly's location, if necessary, to secure a more desirable location or avoid conflict with utilities.

Construct foundations for roadway illumination assemblies in accordance with Item 416, "Drilled Shaft Foundations," and the details shown on the plans.

- 3.1. **Installation.** Furnish and install roadway illumination assembly components in accordance with the details, dimensions, and requirements shown on the plans. Do not use screw-in type foundations. Install anchor bolts and coat anchor bolt threads in accordance with Item 449, "Anchor Bolts." Erect structures after foundation concrete has attained its design strength as required on the plans and Item 421, "Hydraulic Cement Concrete." Tighten anchor bolts for poles with shoe bases and concrete traffic barrier base poles in accordance with Item 449, "Anchor Bolts." Do not place grout between base plate and foundation. Test installed roadway illumination assemblies in accordance with Item 616, "Performance Testing of Lighting Systems."

- 3.2. **Relocation.** Relocate roadway illumination assembly components in accordance with the details, dimensions, and requirements shown on the plans. Do not use screw-in type foundations. Install existing structures on new foundations in accordance with Section 610.3.1., "Installation." Do not place grout between base plate and foundation. Test installed roadway illumination assemblies in accordance with Item 616, "Performance Testing of Lighting Systems."

Disconnect and remove conductors from abandoned circuits. Remove abandoned conduit or ducts to a point 6 in. below final grade. Reconnect conduit and ducts to be reused. Replace damaged conduit and ducts. Replace conductors.

Unless otherwise shown on the plans, remove abandoned concrete foundations and replace surfacing in accordance with Section 610.3.3., "Removal." Do not remove existing concrete bridge lighting brackets.

Furnish and install new internal conductors, fused and unfused connectors, and lamps. Furnish and install new transformer bases that meet AASHTO and plan requirements when relocating transformer base poles. Destroy existing transformer bases to prevent reuse.

Accept ownership of unsalvageable materials and dispose of in accordance with federal, state, and local regulations.

- 3.3. **Removal.** Remove roadway illumination assembly components in accordance with established industry and utility safety practices.

Remove transformer bases from transformer base poles. Destroy removed transformer bases to prevent reuse. Remove luminaires and luminaire arms from the pole shaft. Stockpile pole shafts, luminaire arms, and assembly hardware at a location designated by the Department. Pole shafts, luminaire arms, and assembly hardware will remain Department property unless otherwise shown on the plans or as directed.

Disconnect and remove conductors from abandoned circuits. Remove abandoned conduit and ducts to a point 6 in. below final grade.

Unless otherwise shown on the plans, remove abandoned concrete foundations, including steel, to a point 2 ft. below final grade. Backfill the hole with material that is equal in composition and density to the surrounding area. Replace surfacing material with similar material to an equivalent condition. Do not remove existing concrete bridge lighting brackets.

Accept ownership of unsalvageable materials and dispose of in accordance with federal, state, and local regulations.

- 3.4. **Replace Luminaires.** Remove existing luminaires. Furnish and install luminaires in accordance with the details, dimensions, and requirements shown on the plans. Test installed luminaires in accordance with Item 616, "Performance Testing of Lighting Systems."

4. MEASUREMENT

This Item will be measured as each roadway illumination assembly installed, relocated, or removed; or by each luminaire replaced.

5. PAYMENT

The work performed and materials furnished in accordance with this Item and measured as provided under "Measurement" will be paid for at the unit price bid for "Install Roadway Illumination Assemblies" of the types specified, "Relocate Roadway Illumination Assemblies" of the types specified, "Remove Roadway Illumination Assemblies" of the types specified, or "Replace Luminaires" of the types specified. The Department will pay for electrical energy consumed by the lighting system.

New drilled shaft foundations will be paid for under Item 416, "Drilled Shaft Foundations." New concrete riprap placed around foundations will be paid for under Item 432, "Riprap." New conduit will be paid for under Item 618, "Conduit." New conductors, except the conductors internal to the pole, will be paid for under Item 620, "Electrical Conductors." New duct cable will be paid for under Item 622, "Duct Cable." New ground boxes will be paid for under Item 624, "Ground Boxes." New electrical services will be paid for under Item 628, "Electrical Services."

- 5.1. **Installation.** This price is full compensation for furnishing, installing, and testing luminaires; furnishing and installing lamps, luminaire arms, brackets, poles, anchor bolt assemblies, templates, internal conductors, and connections; conducting system performance testing; and materials, equipment, labor, tools, and incidentals.
- 5.2. **Relocation.** This price is full compensation for salvaging and relocating the existing conduit and duct; removing existing foundations, backfilling, and surface placement; removing, erecting, connecting, and testing illumination assemblies; removing existing conductors; furnishing and installing new anchor bolt assemblies, templates, transformer bases, lamps, connections, and conductors; replacing damaged components; disposing of unsalvageable materials; and materials, equipment, labor, tools, and incidentals.
- 5.3. **Removal.** This price is full compensation for removing, salvaging, disassembling, and stockpiling illumination assemblies; salvaging and relocating existing conduit; removing existing foundations; backfilling and surface placement; splicing existing conductors; disposing of unsalvageable materials; and materials, equipment, labor, tools, and incidentals.

- 5.4. **Replace Luminaires.** This price is full compensation for removing, salvaging, disassembling, and stockpiling existing luminaires; furnishing and installing new luminaires, connections, and conductors internal to the pole; replacing damaged components; disposing of unsalvageable materials; and materials, equipment, labor, tools, and incidentals.

Item 613

High Mast Illumination Poles



1. DESCRIPTION

Furnish and install high mast illumination poles.

2. MATERIALS

Provide new materials that comply with the details shown on the plans, the requirements of this Item, and the pertinent requirements of the following Items:

- Item 416, "Drilled Shaft Foundations"
- Item 421, "Hydraulic Cement Concrete"
- Item 432, "Riprap"
- Item 441, "Steel Structures"
- Item 442, "Metal for Structures"
- Item 445, "Galvanizing"
- Item 449, "Anchor Bolts"
- Item 618, "Conduit"

Use alloy steel or medium strength mild steel anchor bolts that comply with Section 449.2.1., "Bolts and Nuts."

3. CONSTRUCTION

Perform work in accordance with the details shown on the plans, and the requirements of this Item. Provide components that fit together properly.

Use established industry and utility safety practices when installing high mast poles located near overhead or underground utilities. Consult with the appropriate utility company before beginning work.

- 3.1. **Standard Design.** Fabricate poles in accordance with this Item and the plans. Alternate designs are not permitted.
- 3.2. **Shop Drawings.** Do not submit shop drawings for high mast illumination poles fabricated in accordance with this Item and the plans.
- 3.3. **Fabrication.** Fabricate and weld in accordance with Item 441, "Steel Structures," AWS D1.1, *Structural Welding Code—Steel*, and the requirements of this Item. Match-mark pole shaft sections as shown on the plans.

Fabrication plants that produce high mast illumination poles must be approved in accordance with DMS-7380, "Steel Non-Bridge Member Fabrication Plant Qualification." The Construction Division maintains a list of approved high mast illumination pole fabrication plants.

Provide circumferential welds only at the top attachment and base plates. Grind or smooth the longitudinal seam welds to the same radius as contacted shaft corners for the length of the lap plus at least 6 in. at each slip joint splice. Ensure acceptable seam weld profiles for the remainder of the pole exterior. Provide full-penetration longitudinal seam welds for a length of 1.5 diameters plus at least 6 in. in outer sections at splices and base plates. Provide 85% minimum penetration in longitudinal seam welds at other pole sections.

Provide longitudinal seam weld and fit-up that will minimize acid entrapment during later galvanizing. Use at most 2 longitudinal seam welds in each section.

Permanently mark each pole base plate with the insignia or trademark of the fabrication plant. Place the mark on the pole base plate adjacent to the handhole access compartment.

Hot-dip galvanize fabricated pole sections and associated parts in accordance with Item 445, "Galvanizing." Punch or drill holes in steel parts or members, when allowed, before galvanizing. Fabrication tolerances are given in Table 1.

Provide ultrasonic testing (UT) of the shaft to base plate weld joint with a procedure approved by the Department. Perform UT at this joint after galvanizing.

Table 1
Fabrication Tolerances

Part	Dimension	Tolerance (in.)
Pole shaft	Length (unassembled sections)	±1
	Shaft Thickness ¹	+0.12, -0.02
	I.D. of outside slip fitting	+1/8, -1/16
	O.D. of inside slip fitting	+1/32, -1/8
	Difference between flats or diameter	±1/4
	Straightness	1/8 in 10 ft.
	Attachment locations	±1
Assembled pole shaft	Perpendicular to base plate	1/8 in 24 in.
	Shaft centered on base plate	±1/4
	Twist in shaft ²	4° in 100 ft.
	Position of winch channel	±1/4
Base plate	Overall	±1/4
	Thickness	+1/4, -1/16
	Deviations from flat	3/16 in 24 in.
	Spacing between holes	±3/16
	Bolt hole size	±1/16
Anchor bolt templates	Outside diameter	±1/8
	Inside diameter	+1/4
	Thickness	+1/4, -1/32
	Spacing between holes	±1/16
	Bolt hole size	±1/16
Anchor bolts	Length	±1/2
	Threaded Length	±1/2
	Galvanized Length	-1/4
Misc.	Bolt hole spacing	±1/16

1. Adjust pole diameter if shaft thickness exceeds nominal thickness by 0.02 in. or more. Change the splice length for this adjustment.
2. The Department may accept an excessive twist for individual pole sections, provided the top of pole is within twist tolerance for assembled sections.

3.4.

Installation. Stake and install high mast illumination poles as shown on the plans. The Engineer may shift the assembly locations, within design guidelines, where necessary to secure a more desirable location or to avoid conflict with utilities.

Use established industry and utility safety practices when installing poles located near overhead or underground utilities. Consult with the appropriate utility before beginning work.

Prevent scarring or marring of the poles. Repair galvanized surfaces damaged in assembly, transit, or installation; or for steel parts or members welded after galvanizing in accordance with Section 445.3.5., "Repairs."

Provide riprap around pole foundations in accordance with Item 432, "Riprap," and the details shown on the plans.

- 3.4.1. **Foundations.** Construct foundations for high mast illumination poles in accordance with Item 416, "Drilled Shaft Foundations," and the details shown on the plans.

Before placing concrete for the drilled shaft foundation, inspect anchor bolts to verify proper projecting length of bolts, bolt pattern, orientation of pattern, bolt alignment, and bolt galvanizing are as shown on the plans. Orient anchor bolts to provide 2 bolts on the reference line as shown on the plans. Ensure the anchor bolts are electrically bonded to the reinforcing steel as shown on the plans.

Ensure anchor bolts and templates are rigidly held in position during concrete placement. Positioning devices may be tack welded to steel template, but not to any portion of the anchor bolts. Hold conduit in place with a bar attached to the upper template and cap conduit before placing concrete. Ream conduit to remove burrs and sharp edges after placing concrete. Install bell ends or bushings on the conduit.

- 3.4.2. **Pole Assembly.** Assemble poles on blocking using a minimum of 2 hydraulic rams at the splices. Support the free end of the section being assembled with hoist equipment. Apply assembly force using hydraulic rams with sufficient capacity to properly draw the sections together with little or no remaining gaps. Mark poles with permanent ink to indicate designed lap length. Ensure splices are a minimum of 90% or a maximum of 110% of the planned lap. Mark the 90% and 110% locations before assembling the pole. Obtain written approval from the Department for splices that do not meet lap tolerances before erecting the pole.

- 3.4.3. **Pole Installation.** Install structures after foundation concrete has attained its design strength as required on the plans and Item 421, "Hydraulic Cement Concrete." Coat anchor bolt threads and tighten anchor bolts in accordance with Item 449, "Anchor Bolts." Erect and align the poles within 12 in. of vertical. Use enough temporary slings, chains, or wire rope to prevent unintentional separation of the pole sections. Orient poles so a worker can see into the access hole while facing oncoming traffic.

After the high mast pole has been plumbed and all nuts are tight, tack-weld each anchor bolt nut to its washer in 2 places and tack-weld each washer to the base plate in 2 places. Tack weld in accordance with Item 441, "Steel Structures," the AWS D1.1, *Structural Welding Code—Steel*, and the requirements of this Item. Never weld components to the bolt. Repair galvanizing damage on bolts, nuts, and washers in accordance with Section 445.3.5., "Repairs," after tack welding. Do not grout between the base plate and foundation.

4. MEASUREMENT

This Item will be measured as each high mast illumination pole installed.

5. PAYMENT

The work performed and materials furnished in accordance with this Item and measured as provided under "Measurement" will be paid for at the unit price bid for "High Mast Illumination Poles" of the wind design and height specified. This price is full compensation for furnishing, fabricating, galvanizing, assembling and installing the pole on a foundation; anchor bolts, nuts, washers, and templates; conduit, ground rods, and wiring; and materials, equipment, labor, tools, and incidentals.

New drilled shaft foundations will be paid for under Item 416, "Drilled Shaft Foundations." New riprap will be paid for under Item 432, "Riprap." New high mast illumination assemblies will be paid for under Item 614, "High Mast Illumination Assemblies." New ground boxes will be paid for under Item 624, "Ground Boxes." New electrical services will be paid for under Item 628, "Electrical Services."

Item 614

High Mast Illumination Assemblies



1. DESCRIPTION

Furnish and install high mast illumination assemblies.

2. MATERIALS

Provide new materials that comply with the details shown on the plans, the requirements of this Item, and the pertinent requirements of the following Items:

- Item 441, "Steel Structures"
- Item 442, "Metal for Structures"
- Item 445, "Galvanizing"
- Item 616, "Performance Testing of Lighting Systems"
- Item 620, "Electrical Conductors"

Fabrication plants that produce high mast rings and support assemblies must be approved in accordance with DMS-7380, "Steel Non-Bridge Member Fabrication Plant Qualification." The Department maintains an MPL of approved high mast ring and support assembly fabrication plants.

Furnish light fixtures from new materials that are in accordance with DMS-11020, "High Mast Light Fixtures."

Furnish other high mast components from new material that are in accordance with DMS-11021, "High Mast Illumination Assembly Kits."

Provide prequalified high mast illumination assembly kits and light fixtures from the Department's MPL. When required by the Engineer, notify the Department in writing of selected materials from the MPL intended for use on each project.

Do not provide shop drawings for high mast ring and support assemblies fabricated in accordance with this Item and the details on the plans. For proposed deviations that do not affect the basic structural behavior of the high mast ring and support assembly, electronically submit shop drawings in accordance with Item 441, "Steel Structures." The submission of shop drawings is only required the first time each proposed non-structural deviation is used. Structural deviations from the approved drawings are not permitted.

3. CONSTRUCTION

Perform work in accordance with the details shown on the plans and the requirements of this Item. Permanently mark each high mast ring and support assembly with the insignia or trademark of the fabrication plant. Place the mark at an approved location. Galvanize the ring assemblies, assemble the ring halves in the shop to ensure proper fit, and match-mark the ring halves before shipping. Prevent scarring or marring of the ring assemblies. Replace damaged components.

Repair damaged galvanized areas of the ring assembly in accordance with Section 445.3.5., "Repairs."

Before installation, sample and test fixtures in accordance with Tex-1110-T. Test installed fixtures in accordance with Item 616, "Performance Testing of Lighting Systems."

4. MEASUREMENT

This Item will be measured as each high mast illumination assembly installed.

5. PAYMENT

The work performed and materials furnished in accordance with this Item and measured as provided under "Measurement" will be paid for at the unit price bid for "High Mast Illumination Assemblies" of the types specified. This price is full compensation for furnishing, installing and testing light fixtures, ballasts, lamps, wire rope, rings and ring support assemblies; aiming light fixtures; furnishing and installing obstruction lights, hoisting assemblies, power drive assemblies, transformers, conductors on the load side of the high mast pole's disconnect, electrical equipment, electrical cord, junction boxes and enclosures; conducting system performance testing; and materials, equipment, labor, tools, and incidentals.

New poles for high mast illumination assemblies will be paid for under Item 613, "High Mast Illumination Poles." New electrical services will be paid for under Item 628, "Electrical Services." The Department will pay for electrical energy consumed by the lighting system.

Item 616

Performance Testing of Lighting Systems



1. DESCRIPTION

Test the performance of roadway and high mast lighting systems.

2. CONSTRUCTION

Perform tests on the lighting system and tests required by Item 618, "Conduit," Item 620, "Electrical Conductors," and Item 622, "Duct Cable." Ensure all components are properly installed.

Place the lighting system in operation for a 14-day test period. Burn the lighting system steadily for 48 hr. Then cycle the photocell or other control device for 12 days.

Pass a 14-day performance test of the lighting system.

Replace materials that are damaged or have failed before acceptance. Damaged illumination assemblies, except those damaged by the Contractor, and minor failures of lamps, ballasts, and photocells are not cause for modifying or restarting the performance test.

Replace failed or damaged existing lighting system components when caused by the Contractor.

The Department will relieve the Contractor of maintenance responsibilities upon passing a 14-day performance test of the lighting system and acceptance of the Contract.

3. MEASUREMENT AND PAYMENT

The work performed, materials furnished, equipment, labor, tools, and incidentals will not be measured or paid for directly but will be subsidiary to pertinent Items. The Department will pay for electrical energy consumed by the lighting system.

Item 617

Temporary Roadway Illumination



1. DESCRIPTION

Furnish and install temporary roadway illumination.

2. MATERIALS

Furnish new or used materials that comply with the details shown on the plans, the requirements of this Item, and the pertinent requirements of the following Items, except for measurement and payment:

- Item 416, "Drilled Shaft Foundations"
- Item 610, "Roadway Illumination Assemblies"
- Item 613, "High Mast Illumination Poles"
- Item 614, "High Mast Illumination Assemblies"
- Item 618, "Conduit"
- Item 620, "Electrical Conductors"
- Item 621, "Tray Cable"
- Item 622, "Duct Cable"
- Item 624, "Ground Boxes"
- Item 627, "Treated Timber Poles"
- Item 628, "Electrical Services"

Provide utility-grade aluminum service drop cable consisting of one bare aluminum conductor, steel reinforced (ACSR), supporting 2 insulated conductors for overhead electrical work.

Use materials provided by the Department only in authorized locations on the Contract for which the materials were intended. Materials furnished by the Department and the location for pickup will be shown on the plans or as directed.

3. CONSTRUCTION

Perform work in accordance with the details shown on the plans, the NEC, the NESC, and the requirements of this Item.

Use established industry and utility safety practices when installing, relocating, or removing electrical and lighting equipment located near overhead or underground utilities. Consult with the appropriate utility before beginning work.

Tension and sag overhead conductors with guys and anchors in accordance with utility distribution practices.

Install conduit and electrical conductors, tray cable, or duct cable as shown on the plans. Install ground boxes as shown on the plans. Install electrical services as shown on the plans. Install concrete foundations as shown on the plans.

Install roadway illumination assemblies (poles with luminaire arms and light fixtures) as shown on the plans. The Engineer may shift the locations, within design guidelines, where necessary to secure a more desirable location or to avoid conflict with utilities.

Use utility grade materials for overhead electrical work. Maintain a minimum of 22-ft. clearance above the roadway for overhead electrical work. Do not support overhead wiring with existing luminaire poles or breakaway luminaire poles.

Operate and maintain the temporary illumination system. Relocate temporary illumination system as shown on the plans.

Remove temporary illumination system when no longer needed. Remove abandoned concrete foundations to a point 2 ft. below final grade. Backfill the hole with material equal in composition and density to the surrounding area. Replace surfacing material with similar material to an equivalent condition.

Replace materials furnished by the Department that are scarred, battered, broken, or lost. Replace damaged temporary illumination materials intended for permanent installation. Return all Department-owned material not used during the Contract upon completion of the work, in original condition, to the location from which the material was obtained, or as directed.

4. MEASUREMENT

This Item will be measured by each roadway illumination assembly installed or relocated; or by the month the system is operated and maintained.

5. PAYMENT

The work performed and materials furnished in accordance with this Item and measured as provided under "Measurement" will be paid for at the unit price bid for "Temporary Roadway Illumination" of the type specified. This price is full compensation for installing, relocating, and removing illumination assemblies temporary wiring, foundations and electrical services; and materials, equipment, labor, tools, and incidentals.

Electrical energy consumed by the Contractor on an existing Department electrical service will be paid for by the Department.

Costs for utility-owned power line extensions, connection charges, meter charges, consumption charges, and other charges will be paid for by the Department. The Department will reimburse the Contractor the amount billed by the utility plus an additional 5% of the invoice cost will be paid for labor, equipment, administrative costs, superintendence, and profit.

Item 618

Conduit



1. DESCRIPTION

Furnish and install conduit.

2. MATERIALS

Provide new materials that comply with the details shown on the plans, the requirements of this Item, and the pertinent requirements of the following Items:

- Item 400, "Excavation and Backfill for Structures"
- Item 476, "Jacking, Boring, or Tunneling Pipe or Box"

When specified on the plans, provide:

- rigid metal conduit (RMC);
- intermediate metal conduit (IMC);
- electrical metallic tubing (EMT);
- polyvinyl chloride (PVC) conduit;
- high density polyethylene (HDPE) conduit;
- liquidtight flexible metal conduit (LFMC); or
- liquidtight flexible nonmetallic conduit (LFNC).

Furnish conduit from new materials in accordance with DMS-11030, "Conduit."

Provide prequalified conduit from the Department's MPL. When required by the Engineer, notify the Department in writing of selected materials from the MPL intended for use on each project.

Provide other types of conduit not on the MPL that comply with the details shown on the plans and the NEC. Fabricate fittings such as junction boxes and expansion joints from a material similar to the connecting conduit, unless otherwise shown on the plans. Use watertight fittings. Do not use set screw and pressure-cast fittings. Steel compression fittings are permissible. When using HDPE conduit, provide fittings that are UL-listed as electrical conduit connectors or thermally fused using an electrically heated wound wire resistance welding method.

Use red 3-in. 4-mil polyethylene underground warning tape that continuously states "Caution Buried Electrical Line Below."

3. CONSTRUCTION

Perform work in accordance with the details shown on the plans and the requirements of this Item.

Use established industry and utility safety practices when installing conduit located near underground utilities. Consult with the appropriate utility company before beginning work.

Install conduit a minimum of 18 in. deep below finished grade unless otherwise shown on the plans. Meet the requirements of the NEC when installing conduit. Secure and support conduit placed for concrete encasement in such a manner that the alignment will not be disturbed during placement of the concrete. Cap ends of conduit and close box openings before concrete is placed.

Ream conduit to remove burrs and sharp edges. Use a standard conduit cutting die with a 3/4-in. taper per foot when conduit is threaded in the field. Fasten conduit placed on structures with conduit straps or hangers as shown on the plans or as directed. Fasten conduit within 3 ft. of each box or fitting and at other locations shown on the plans or as directed. Use metal conduit clamps that are galvanized malleable or stainless steel unless otherwise shown on the plans. Use 2-hole type clamps for 2-in. diameter or larger conduit.

Fit PVC and HDPE conduit terminations with bushings or bell ends. Fit metal conduit terminations with a grounding type bushing, except conduit used for duct cable casing that does not terminate in a ground box and is not exposed at any point. Conduit terminating in threaded bossed fittings does not need a bushing. Before installation of conductors or final acceptance, pull a properly sized mandrel or piston through the conduit to ensure that it is free from obstruction. Cap or plug empty conduit placed for future use.

Perform trench excavation and backfilling as shown on the plans or as directed, and in accordance with Item 400, "Excavation and Backfill for Structures." Excavation and backfilling will be subsidiary to the installation of the conduit.

Jack and bore as shown on the plans or as directed, and in accordance with Item 476, "Jacking, Boring, or Tunneling Pipe or Box."

Place warning tape approximately 10 in. above trenched conduit. Where existing surfacing is removed for placing conduit, repair by backfilling with material equal in composition and density to the surrounding areas and by replacing any removed surfacing, such as asphalt pavement or concrete riprap, with like material to equivalent condition. Mark conduit locations as directed.

4. MEASUREMENT

This Item will be measured by the foot of conduit.

This is a plans quantity measurement Item. The quantity to be paid is the quantity shown in the proposal, unless modified by Article 9.2., "Plans Quantity Measurement." Additional measurements or calculations will be made if adjustments of quantities are required.

5. PAYMENT

The work performed and materials furnished in accordance with this Item and measured as provided under "Measurement" will be paid for at the unit price bid for "Conduit" of the type and size specified and the installation method specified as applicable. This price is full compensation for furnishing and installing conduit; hanging, strapping, jacking, boring, tunneling, trenching, and furnishing and placing backfill; encasing in steel or concrete; replacing pavement structure, sod, riprap, curbs, or other surface; marking location of conduit (when required); furnishing and installing fittings, junction boxes, and expansion joints; and materials, equipment, labor, tools, and incidentals.

Flexible conduit will not be paid for directly but will be subsidiary to pertinent Items. Unless otherwise shown on the plans, no payment will be allowed under this Item for conduit used on electrical services or in foundations.

Item 620

Electrical Conductors



1. DESCRIPTION

Furnish and install electrical conductors, except conductors specifically covered by other Items.

2. MATERIALS

Provide new materials that comply with the details shown on the plans and the requirements of this Item. Use stranded insulated conductors that are rated for 600 volts; approved for wet locations; and marked in accordance with UL, NEC, and CSA requirements. Furnish electrical conductors in accordance with DMS-11040, "Electrical Conductors."

Provide prequalified electrical conductors from the Department's MPL. When required by the Engineer, notify the Department in writing of selected materials from the MPL intended for use on each project.

Ensure all grounding conductors size 8 AWG and larger are stranded, except for the grounding electrode conductor at the electrical service, which will be a solid conductor.

Use white insulation for grounded (neutral) conductors, except grounded conductors size 4 AWG and larger may be black with white tape marking at every accessible location. Do not use white insulation or marking for any other conductor except control wiring specifically shown on the plans.

Ensure insulated grounding conductors are green except insulated grounding conductors size 4 AWG and larger may be black with green tape marking at every accessible location. Do not use green insulation or marking for any other conductor except control wiring specifically shown on the plans.

3. CONSTRUCTION

Perform work in accordance with the details shown on the plans and the requirements of this Item.

Splice conductors only in junction boxes, ground boxes, and transformer bases, and in poles and structures at the handholes. Splice as shown on the plans. Do not exceed the manufacturer's recommended pulling tension. Use lubricant as recommended by the manufacturer. Install conductors in accordance with the NEC.

Make insulation resistance tests on the conductors before making final connections, and ensure each continuous run of insulated conductor has a minimum DC resistance of 5 megohms when tested at 1,000 volts DC. The Engineer may require verification testing of all or part of the conductor system. The Engineer will witness these verification tests. Replace conductors exhibiting an insulation resistance of less than 5 megohms at no additional cost to the Department.

4. MEASUREMENT

This Item will be measured by the foot of each single conductor.

This is a plans quantity measurement Item. The quantity to be paid is the quantity shown in the proposal, unless modified by Article 9.2., "Plans Quantity Measurement." Additional measurements or calculations will be made if adjustments of quantities are required.

5. PAYMENT

The work performed and materials furnished in accordance with this Item and measured as provided under "Measurement" will be paid for at the unit price bid for "Electrical Conductors" of the types and sizes specified. This price is full compensation for furnishing, installing, and testing electrical conductors; furnishing and installing breakaway connectors; and for materials, equipment, labor, tools, and incidentals, except:

- conductors used in connecting the components of electrical services will be paid for under Item 628, "Electrical Services";
- conductors inside roadway illumination assemblies will be paid for under Item 610, "Roadway Illumination Assemblies";
- conductors inside of traffic signal pole assemblies will be paid for under this Item; and
- conductors used for internal wiring of equipment will not be paid for directly but will be subsidiary to pertinent Items.

Item 621

Tray Cable



1. DESCRIPTION

Furnish and install tray cable.

2. MATERIALS

Provide new materials that comply with the details shown on the plans and meet the requirements of Item 620, "Electrical Conductors."

Furnish tray cable from new materials in accordance with DMS-11050, "Tray Cable."

Provide prequalified tray cable from the Department's MPL. When required by the Engineer, notify the Department in writing of selected materials from the MPL intended for use on each project.

3. CONSTRUCTION

Perform work in accordance with the details shown on the plans and the requirements of this Item.

Provide an additional 5 ft. of cable coiled in each ground box when installing cable in underground conduit. Splice tray cable conductors only at locations shown on the plans. Obtain the Engineer's written approval for each splice. Ensure allowed splices are watertight. Test the cable's conductors after installation and before any connection. Remove and replace tray cable exhibiting a DC insulation resistance of less than 5 megohms at 1,000 volts DC at no additional cost to the Department.

4. MEASUREMENT

This Item will be measured by the foot of tray cable.

This is a plans quantity measurement Item. The quantity to be paid is the quantity shown in the proposal unless modified by Article 9.2., "Plans Quantity Measurement." Additional measurements or calculations will be made if adjustments of quantities are required.

5. PAYMENT

The work performed and materials furnished in accordance with this Item and measured as provided under "Measurement" will be paid for at the unit price bid for "Tray Cable" of the types and sizes specified. This price is full compensation for furnishing and installing materials and for equipment, labor, tools, and incidentals.

Item 622

Duct Cable



1. DESCRIPTION

Furnish and install duct cable consisting of a complete assembly of conductors enclosed in a high density polyethylene conduit.

2. MATERIALS

Provide new materials that comply with the details shown on the plans, with conductors that meet the material requirements of Item 620, "Electrical Conductors." Furnish duct cable from new materials in accordance with DMS-11060, "Duct Cable."

Provide prequalified duct cable from the Department's MPL. When required by the Engineer, notify the Department in writing of selected materials from the MPL intended for use on each project.

Ensure the complete assembly is packaged on reels with sufficient diameter to prevent permanent set or damage to the duct cable. Ensure each reel is clearly and durably marked to show the voltage rating, type of insulation, number of conductors, conductor size, length, duct size, and either the name or the trademark of the manufacturer.

3. CONSTRUCTION

Perform work in accordance with the details shown on the plans and the requirements of this Item.

Use established industry and utility safety practices when installing duct cable located near underground utilities. Consult with the appropriate utility company before beginning work.

Install duct cable by open trench methods in accordance with the NEC. Backfill the trench in accordance with Item 400, "Excavation and Backfill for Structures," except for measurement and payment. When removal of existing pavement or concrete surface is allowed, backfill with material equal in composition and density to the surrounding area and replace removed surfacing, such as asphalt pavement or concrete riprap, with like material to equivalent condition or as shown on the plans.

Splicing the duct is not allowed. Make all connections in ground boxes or pole bases. Form bends with large radii to provide free movement of conductors. After installation, demonstrate the conductors can move freely. Duct cable that has been kinked or in which the conductors cannot move freely is not acceptable and will be repaired or replaced at no cost to the Department. Splice conductors and test insulation in accordance with Item 620, "Electrical Conductors."

4. MEASUREMENT

This Item will be measured by the foot of duct cable.

This is a plans quantity measurement Item. The quantity to be paid is the quantity shown in the proposal unless modified by Article 9.2., "Plans Quantity Measurement." Additional measurements or calculations will be made if adjustments of quantities are required.

5. PAYMENT

The work performed and materials furnished in accordance with this Item and measured as provided under "Measurement" will be paid for at the unit price bid for "Duct Cable" of the types and sizes specified. This price is full compensation for furnishing and installing all duct cable; excavating and backfilling the trenches; replacing riprap, pavement structure, topsoil, sod, or other surface; testing insulation resistance; and materials, equipment, labor, tools, and incidentals.

Item 624

Ground Boxes



1. DESCRIPTION

- **Installation.** Construct, furnish, and install ground boxes complete with lids.
- **Removal.** Remove existing ground boxes.

2. MATERIALS

Provide new materials that comply with the details shown on the plans, the requirements of this Item, and the pertinent requirements of the following items:

- Item 420, "Concrete Substructures"
- Item 421, "Hydraulic Cement Concrete"
- Item 432, "Riprap"
- Item 440, "Reinforcement for Concrete"
- Item 618, "Conduit"
- Item 620, "Electrical Conductors"

Provide fabricated precast polymer concrete ground boxes in accordance with DMS-11070, "Ground Boxes." Provide prequalified ground boxes from the Department's MPL. When required by the Engineer, notify the Department in writing of selected materials from the MPL intended for use on each project.

Provide other precast or cast-in-place ground boxes that comply with the details shown on the plans.

3. CONSTRUCTION

Perform work in accordance with the details shown on the plans and the requirements of this Item.

Use established industry and utility safety practices when installing or removing ground boxes located near underground utilities. Consult with the appropriate utility company before beginning work.

- 3.1. **Installation.** Fabricate and install ground boxes in accordance with the details, dimensions, and requirements shown on the plans. Install ground box to approved line and grade.

Construct precast and cast-in-place concrete ground boxes in accordance with Item 420, "Concrete Substructures," and Item 440, "Reinforcement for Concrete."

Construct concrete aprons as shown on the plans and in accordance with Item 432, "Riprap," and Item 440, "Reinforcement for Concrete."

- 3.2. **Removal.** Remove existing ground boxes and concrete aprons to at least 6 in. below the conduit level. Uncover conduit to a sufficient distance so that 90 degree bends can be removed and conduit reconnected. Clean the conduit in accordance with Item 618, "Conduit." Replace conduit within 5 ft. of the ground box. Remove old conductors and install new conductors as shown on the plans. Backfill area with material equal in composition and density to the surrounding area. Replace surfacing material with similar material to an equivalent condition.

4. MEASUREMENT

This Item will be measured by each ground box installed complete in place or each ground box removed.

5. PAYMENT

The work performed and materials furnished in accordance with this Item and measured as provided under "Measurement" will be paid for at the unit price bid for "Ground Box" of the types and sizes specified and for "Remove Ground Box."

- 5.1. **Installation.** This price is full compensation for excavating and backfilling; constructing, furnishing, and installing ground boxes and concrete aprons; and material, equipment, labor, tools, and incidentals. All wiring connections required inside the ground box will be considered subsidiary to this bid item. Conduit will be paid for under Item 618, "Conduit." Electrical conductors will be paid for under Item 620, "Electrical Conductors."
- 5.2. **Removal.** This price is full compensation for removing and disassembling ground boxes and concrete aprons; excavating, backfilling, and surface placement; removing old conductors; disposal of unsalvageable materials; and materials, equipment, labor, tools, and incidentals. Cleaning of conduit is subsidiary to this Item. Conduit replaced within 5 ft. of the ground box will be subsidiary to this Item. Additional conduit will be paid for under Item 618, "Conduit." Installation of conductors will be paid for under Item 620, "Electrical Conductors."

Item 625

Zinc-Coated Steel Wire Strand



1. DESCRIPTION

Furnish and install zinc-coated steel wire strand.

2. MATERIALS

Provide new materials in accordance with ASTM A475, Utilities Grade or better, Class A coating. These requirements include, but are not limited to, the properties given in Table 1. Furnish 7 wires per strand.

Table 1
Dimensions and Properties

Nominal Diameter of Strand (in.)	Nominal Diameter of Coated Wires (in.)	Approx. Weight per 1,000 ft. (lb.)	Minimum Breaking Strength (lb.)	Minimum Zinc Coating Wt. Class A (oz./sq. ft.)
3/16	0.065	80	2,400	0.50
1/4	0.080	121	4,750	0.60
9/32	0.093	164	4,600	0.70
5/16	0.109	225	6,000	0.80
3/8	0.120	273	11,500	0.85
7/16	0.145	399	18,000	0.90
1/2	0.165	517	25,000	0.90

Supply new material. Remove drips, runs, sharp points, voids, and damage from the zinc coating. Samples from each roll of each diameter of strand will be taken. Replace strands failing to meet the requirements of this Item.

3. CONSTRUCTION

Install strands as shown on the plans. Splicing is not permitted.

When the strand is used as a messenger cable or span wire, ground it to the grounding conductor at each pole. Metal poles may be used as the grounding conductor. Ensure a resistance less than 1 ohm from the strand to the ground rod.

4. MEASUREMENT

This Item will be measured by foot of wire strand.

5. PAYMENT

The work performed and materials furnished in accordance with this Item and measured as provided under "Measurement" will be paid for at the unit price bid for "Zinc-Coated Steel Wire Strand" of the sizes specified. This price is full compensation for furnishing, installing, and testing wire strands; and materials, equipment, labor, tools, and incidentals.

Item 627

Treated Timber Poles



1. DESCRIPTION

Furnish and install treated timber poles.

2. MATERIALS

Use new treated southern pine timber poles in accordance with ANSI O5.1, *Specifications and Dimensions for Wood Poles*, and the additional requirements of this Item. Use ANSI Class 5 treated timber poles for electrical services and ANSI Class 2 for all other applications, unless otherwise shown on the plans.

Ensure poles are free from pith holes at the tops and butts. Do not use poles that have a trimmed scar with a depth greater than 2 in., if the diameter is 10 in. or less, or 1/5 the pole diameter at the scar location, if the diameter is more than 10 in. Provide poles that do not deviate from straightness by more than 1 in. for each 10 ft. of length. A pole may only have sweep in one plane and one direction (single sweep), provided a straight line joining the midpoint of the pole at the butt and the midpoint of the pole at the top does not at any intermediate point pass through the external surface of the pole. Timber poles with more than one complete twist of spiral grain are not acceptable.

Butt slivering due to felling is permitted if the distance from the outside circumference is at least 1/4 of the butt diameter and the height is not more than 1 ft. Use preservative treatment in accordance with AWWA U1, Commodity Specification D. Furnish poles with a minimum net retention of preservative treatment in accordance with Table 1.

Mark all poles by branding in accordance with Table 2.

Table 1
Retention of Preservative Treatment

Treatment	Minimum Retention
Creosote	9.0 lb./ft. ³
Pentachlorophenol	0.45 lb./ft. ³
CCA	0.6 lb./ft. ³

Table 2
Timber Pole Markings

Marking	Description of Marking
PTC	Supplier's code or trademark (for example, Pole Treating Company).
F-01	Plant location and year of treatment (for example, Forestville, 2001).
SPC	Species and preservative code (for example, southern pine, creosote).
5-35	Class-length (for example, Class 5, 35-ft. pole).

Place the bottom of the brand squarely on the face of the pole 10 ft. (plus or minus 2 in.) from the butt.

Furnish a treatment certification with every shipment of treated timber poles that includes:

- name of treating company,
- location of treating plant,
- applicable product standard (AWPA U1),
- charge number,
- date of treatment,
- contents of charge (poles),

- preservative treatment, and
- actual preservative retention values.

3. CONSTRUCTION

Perform work in accordance with the details shown on the plans and the requirements of this Item.

Use established industry and utility safety practices while installing poles located near overhead or underground utilities. Consult with the appropriate utility company before beginning work.

Set the pole a minimum depth in accordance with Table 3, unless otherwise shown on the plans.

Table 3
Pole Setting Depth

Pole Length (ft.)	Min Setting Depth (ft.)
25 or less	4.5
26–30	5.0
31–35	5.5
36–40	6.0
41–45	6.5
46–50	7.0

Locate timber poles as shown on the plans or as directed. Drill holes for setting poles a minimum of 1.5 diameters of the pole butt. Set the poles plumb, unless otherwise shown on the plans. Backfill the holes thoroughly by tamping in 6-in. lifts. After tamping to grade, place additional backfill material in a 6-in. high cone around the pole to allow for settling. Use material equal in composition and density to the surrounding area. Repair surface where existing surfacing material is removed, such as asphalt pavement or concrete riprap, with like material to equivalent condition.

4. MEASUREMENT

This Item will be measured by each timber pole installed.

5. PAYMENT

The work performed and materials furnished in accordance with this Item and measured as provided under "Measurement" will be paid for at the unit price bid for "Treated Timber Pole" of the various lengths and classes specified. This price is full compensation for furnishing and installing timber poles; and for all hardware; and materials, equipment, labor, tools, and incidentals.

This payment clause excludes payment for Treated Timber Poles when subsidiary to another Item.

Item 628

Electrical Services



1. DESCRIPTION

- Installation. Furnish and install electrical services.
- Relocation. Relocate existing electrical services.
- Removal. Remove existing electrical services.

2. MATERIALS

Provide materials that comply with the details shown on the plans, the requirements of this Item, and the pertinent requirements of the following Items:

- Item 441, "Steel Structures"
- Item 445, "Galvanizing"
- Item 449, "Anchor Bolts"
- Item 618, "Conduit"
- Item 620, "Electrical Conductors"
- Item 627, "Treated Timber Poles"
- Item 656, "Foundations for Traffic Control Devices"

For the installation of electrical services, use new materials that meet the requirements of the NEC, UL, CSA, and NEMA, and are in accordance with DMS-11080, "Electrical Services."

Provide prequalified electrical services prequalified from the Department's MPL. When required by the Engineer, notify the Department in writing of selected materials from the MPL intended for use on each project.

3. CONSTRUCTION

Perform work in accordance with the details shown on the plans and the requirements of this Item. Use established industry and utility safety practices when installing, relocating, or removing electrical services located near overhead or underground utilities. Consult with the appropriate utility company before beginning work.

- 3.1. **Installation.** Furnish and install electrical service equipment. Ensure components of the electrical service meet the requirements of the Electrical Detail Standards. Follow NEC and local utility company requirements when installing the electrical equipment. Coordinate the utility companies' work for providing service.
- 3.2. **Relocation.** Coordinate relocation with the appropriate utility company before beginning work. Remove existing electrical service according to "Removal" under this Item. Reinstall existing electrical service according to "Installation" of this Item. Replace or add circuit breakers as noted on the plans.
- 3.3. **Removal.** Coordinate removal with the appropriate utility company before beginning work. Before the removal of the electrical service, disconnect and isolate any existing electrical service equipment in accordance with the utility company's requirements.

Remove existing electrical service support a minimum of 2 ft. below finish grade unless otherwise shown on the plans. Repair the remaining hole by backfilling with material equal in composition and density to the surrounding area. Replace any surfacing such as asphalt pavement or concrete riprap with like material to equivalent condition.

Disconnect conductors and remove them from the conduit. Cut off all protruding conduit 6 in. below finished grade. Abandoned conduit need not be removed unless shown on the plans.

Reconnect conductors and conduit to be reused when shown on the plans. Make all splices in ground boxes unless otherwise shown on the plans.

Accept ownership of unsalvageable materials, and dispose of them in accordance with federal, state, and local regulations.

4. MEASUREMENT

This Item will be measured by each electrical service installed, relocated, or removed.

5. PAYMENT

The work performed and materials furnished in accordance with this Item and measured as provided under "Measurement" will be paid for at the unit price bid for "Electrical Services" of the types specified, "Relocate Electrical Services," or "Remove Electrical Services."

- 5.1. **Installation.** This price is full compensation for paying all fees, permits, and other costs; making arrangements with the utility company for all work and materials provided by the utility company; furnishing, installing, and connecting all components including poles, service supports, foundations, anchor bolts, riprap, enclosures, switches, breakers, service conduit (from the service equipment including the elbow below ground), fittings, service conductors (from the service equipment including the elbow below ground), brackets, bolts, hangers, hardware; and materials, equipment, labor, tools, and incidentals.
- Costs for utility-owned power line extensions, connection charges, meter charges, consumption charges, and other charges will be paid for by the Department. The Department will reimburse the Contractor the amount billed by the utility plus an additional 5% of the invoice cost will be paid for labor, equipment, administrative costs, superintendence, and profit.
- 5.2. **Relocation.** This price is full compensation for disconnecting and isolating the existing electrical service; relocating the service supports; new service support foundation; backfilling holes; paying all fees, permits, and other costs; making arrangements with the utility company for all work and materials provided by the utility company; removing, disconnecting, installing, and connecting all components including poles, service supports, foundations, anchor bolts, riprap, enclosures, switches, breakers, service conduit (from the service equipment including the elbow below ground), fittings, service conductors (from the service equipment including the elbow below ground), brackets, bolts, hangers, hardware; and materials, equipment, labor, tools, and incidentals.
- Costs for utility-owned power line extensions, connection charges, meter charges, consumption charges, and other charges will be paid for by the Department. The Department will reimburse the Contractor the amount billed by the utility plus an additional 5% of the invoice cost will be paid for labor, equipment, administrative costs, superintendence, and profit.
- 5.3. **Removal.** This price is full compensation for coordinating with the utility company to disconnect and isolate the electrical service; removing the service supports; backfilling holes; and materials, equipment, labor, tools, and incidentals.

Item 636

Signs



1. DESCRIPTION

- **Installation.** Furnish, fabricate, and erect aluminum signs. Sign supports are provided for under other Items.
- **Replacement.** Replace existing signs on existing sign supports.
- **Refurbishing.** Refurbish existing aluminum signs on existing sign supports.

2. MATERIALS

- 2.1. **Sign Blanks.** Furnish sign blank substrates in accordance with DMS-7110, "Aluminum Sign Blanks," and in accordance with the types shown on the plans. Use single-piece sheet-aluminum substrates for Type A (small) signs and extruded aluminum substrates for Type G (ground-mounted) or Type O (overhead-mounted) signs.
- 2.2. **Sign Face Retroreflectorization.** Retroreflectorize the sign faces with flat surface reflective sheeting. Furnish sheeting that meets DMS-8300, "Sign Face Materials." Use retroreflective sheeting from the same manufacturer for the entire sign face background. Ensure that sign legend, symbols, borders, and background exhibit uniform color, appearance, and retroreflectivity when viewed both day and night.
- 2.3. **Sign Messages.** Fabricate sign messages to the sizes, types, and colors shown on the plans. Use sign message material from the same manufacturer for the entire message of a sign. Use screen ink and background reflective sheeting that are from the same manufacturer when fabricating signs.
- Ensure that the screened messages have clean, sharp edges and exhibit uniform color and retroreflectivity. Prevent runs, sags, and voids. Furnish screen inks in accordance with DMS-8300, "Sign Face Materials."
 - Fabricate colored, transparent film legend, and retroreflectorized sheeting legend from materials that meet DMS-8300, "Sign Face Materials."
 - Fabricate non-reflective black film legend from materials meeting DMS-8300, "Sign Face Materials."
 - Furnish direct-applied route markers and other attachments within the parent sign face unless otherwise specified on the plans.
- 2.4. **Hardware.** Use galvanized steel, stainless steel, or dichromate-sealed aluminum for bolts, nuts, washers, lock washers, screws, and other sign assembly hardware. Use plastic or nylon washers to avoid tearing the reflective sheeting. Furnish steel or aluminum products in accordance with DMS-7120, "Sign Hardware."

When dissimilar metals are used, select or insulate metals to prevent corrosion.

3. CONSTRUCTION

- 3.1. **Fabrication.** Sign fabrication plants that produce permanent highway signs must be approved in accordance with DMS-7390, "Permanent Highway Sign Fabrication Plant Qualification." Furnish signs from prequalified fabrication plants listed in the Department's MPL.
- 3.1.1. **Sign Blanks.** Furnish sign blanks to the sizes and shapes shown on the plans and that are free of buckles, warps, burrs, dents, cockles, or other defects. Do not splice individual extruded aluminum panels.

Complete the fabrication of sign blanks, including the cutting and drilling or punching of holes, before cleaning and degreasing. After cleaning and degreasing, ensure the substrate does not come into contact with grease, oils, or other contaminants before the application of the reflective sheeting.

- 3.1.2. **Sheeting Application.** Apply sheeting to sign blanks in conformance with the sheeting manufacturer's recommended procedures.

When using rotational sensitive white sheeting, fabricate signs by applying the sheeting for cut-out legend, symbols, borders, and route marker attachments within the parent sign face with the identification marks or other orientation features in the optimum rotation as identified by the sheeting manufacturer.

Clean and prepare the outside surface of extruded aluminum flanges in the same manner as the sign panel face.

Minimize the number of splices in the sheeting. Overlap the lap-splices by at least 1/4 in. for encapsulated glass bead sheeting unless otherwise recommended by the reflective sheeting manufacturer. Use butt splices for prismatic reflective sheeting. Provide a 1 ft. minimum dimension for any piece of sheeting. Do not splice sheeting for signs fabricated with transparent screen inks or colored transparent films.

- 3.1.3. **Sign Assembly.** Assemble extruded aluminum signs in accordance with the details shown on the plans. Sign face surface variation must not exceed 1/8 in. per foot. Surface misalignment between panels in multi-panel signs must not exceed 1/16 in. at any point.

- 3.1.4. **Decals.** Code and apply sign identification decals in accordance with Item 643, "Sign Identification Decals."

- 3.2. **Storage and Handling.** Ship, handle, and store completed sign blanks and completed signs so that corners, edges, and faces are not damaged. Damage to the sign face that is not visible when viewed at a distance of 50 ft., night or day, will be acceptable. Replace unacceptable signs.

Store all finished signs off the ground and in a vertical position until erected. Store finished sheet aluminum substrate signs in a weatherproof building. Extruded aluminum substrate signs may be stored outside.

Stockpile salvageable materials at the location shown on the plans or as directed. Accept ownership of unsalvageable materials and dispose of them in accordance with federal, state, and local regulations.

- 3.3. **Cleaning.** Wash completed signs in the fabrication shop with a biodegradable cleaning solution acceptable to the manufacturers of the sheeting, colored transparent film, and screen ink to remove grease, oil, dirt, smears, streaks, finger marks, and other foreign material. Wash again before final inspection after erection.

- 3.4. **Installation.** Install signs as shown on the plans or as directed.

- 3.5. **Replacement.** Remove the existing signs from the existing supports and replace with new signs, including mounting hardware, as shown on the plans.

- 3.6. **Refurbishing.** Refurbish existing signs by providing and installing new messages and mounting hardware. Install new retroreflectorized legend and supplemental signs as shown on the plans.

- 3.7. **Documentation.** Provide the following documentation from the sign fabricator with each shipment of furnished signs:

- A notarized original of the Signing Material Statement (Form 2273) with the proper attachments for verification of compliance, and
- A notarized certification stating that the completed signs were fabricated in accordance with this Item and the plans.

4. MEASUREMENT

Signs installed or replaced will be measured by the square foot of the sign face. Signs refurbished will be measured by each sign.

This is a plans quantity measurement item. The quantity to be paid is the quantity shown in the proposal, unless modified by Article 9.2., "Plans Quantity Measurement." Additional measurements or calculations will be made if adjustments of quantities are required.

5. PAYMENT

The work performed and materials furnished in accordance with this item and measured as provided under "Measurement" will be paid for at the unit price bid for "Aluminum Signs," "Replacing Existing Aluminum Signs," or "Refurbishing Aluminum Signs," of the type specified.

- 5.1. **Installation.** This price is full compensation for furnishing and installing new signs and hardware; fabrication of sign panels; treatment of sign panels required before application of the background materials; application of the background materials and messages to the sign panels; furnishing and fabricating frames, wind beams and stiffeners; furnishing bolts, rivets, screws, fasteners, clamps, brackets, and sign support connections; assembling and erecting the signs; preparing and cleaning the signs; and materials, equipment, labor, tools, and incidentals.
- 5.2. **Replacement.** This price is full compensation for furnishing and installing new aluminum signs and hardware; removal of existing signs; fabrication of sign panels; treatment of sign panels required before application of the background materials; application of the background materials and messages to the sign panels; furnishing and fabricating frames, wind beams and stiffeners; furnishing bolts, rivets, screws, fasteners, clamps, brackets, and sign support connections; assembling and erecting the signs; preparing and cleaning the signs; salvaging and disposing of unsalvageable materials; and materials, equipment, labor, tools, and incidentals.
- 5.3. **Refurbishing.** This price is full compensation for modifying existing sign messages; removing and replacing existing route markers, reflectorized legend, or supplemental signs attached to the parent sign; preparing and cleaning the signs; furnishing sheeting and hardware; salvaging and disposing of unsalvageable materials; and materials, equipment, labor, tools, and incidentals.

Item 643

Sign Identification Decals



1. DESCRIPTION

Furnish and install sign identification decals.

2. MATERIALS

Furnish materials that meet the requirements of DMS-8315, "Sign Identification Decals."

Figure 1 shows the sign identification decal design. Table 1 describes the information required in each row of the decal.

Texas Department of Transportation											
C	Fabrication Date										T
J	F	M	A	M	J	J	A	S	O	N	D
	201		202		203		204		205		
	0	1	2	3	4	5	6	7	8	9	
Sheeting MFR - Substrate											
A	B	C	D	E	F	G	H	J	K	L	M
Film MFR											
A	B	C	D	E	F	G	H	J	K	L	M
Sheeting MFR - Legend											
A	B	C	D	E	F	G	H	J	K	L	M
Installation Date											
				0	1	2	3				
	0	1	2	3	4	5	6	7	8	9	
J	F	M	A	M	J	J	A	S	O	N	D
	201		202		203		204		205		
	0	1	2	3	4	5	6	7	8	9	

Figure 1
Decal Design (Row numbers explained in Table 1.)

Table 1
Decal Description
Row Explanation

1 – Sign Fabricator
2 – Month Fabricated
3 – First 3 Digits of Year Fabricated
4 – Last Digit of Year Fabricated
5 – Manufacturer of the Sheeting Applied to the Substrate
6 – Film (colored transparent or non-reflective black) Manufacturer
7 – Manufacturer of the Sheeting for the Legend
8 – Tens digit of Date Installed
9 – Ones Digit of Date Installed
10 – Month Installed
11 – First 3 Digits of Year Installed
12 – Last Digit of Year Installed

3. CONSTRUCTION

- 3.1. **Sign Fabricator.** Code the decal by punching out the following:
- “C” if fabricated by a commercial sign fabricator or “T” if fabricated by the Department or the Texas Department of Criminal Justice;
 - month fabricated;
 - first 3 digits of the year fabricated;
 - fourth digit of the year fabricated; and
 - sheeting, film, and ink manufacturers. (Codes for these manufacturers are located in the Department’s MPL.)

Affix decal to lower left corner of the sign back in an upright position.

4. MEASUREMENT AND PAYMENT

The work performed, materials furnished, equipment, labor, tools, and incidentals will not be measured or paid for directly but will be subsidiary to pertinent Items.

Item 644

Small Roadside Sign Assemblies



1. DESCRIPTION

- **Installation.** Furnish, fabricate, and erect small roadside sign assemblies or bridge mounted clearance sign assemblies consisting of the signs, sign supports, foundations (when required), and associated mounting hardware.
- **Relocation.** Relocate existing small roadside sign assemblies or bridge mounted clearance sign assemblies, and furnish and fabricate material as required.
- **Removal.** Remove existing small roadside sign assemblies or bridge mounted clearance sign assemblies.

2. MATERIALS

Furnish all materials unless otherwise shown on the plans. Furnish only new materials. Furnish and fabricate materials that comply with the following Items and details shown on the plans:

- Item 421, "Hydraulic Cement Concrete"
- Item 440, "Reinforcement for Concrete"
- Item 441, "Steel Structures"
- Item 442, "Metal for Structures"
- Item 445, "Galvanizing"
- Item 636, "Signs"
- Item 643, "Sign Identification Decals"
- Item 656, "Foundations for Traffic Control Devices"

Use galvanized steel, stainless steel, dichromate sealed aluminum, or other materials shown on the plans for pipe, bolts, nuts, washers, lock washers, screws, and other sign assembly hardware. When dissimilar metals are used, select or insulate metals to prevent corrosion.

3. CONSTRUCTION

Construct foundations in accordance with Item 656, "Foundations for Traffic Control Devices." Plumb sign supports. Do not spring or rake posts to secure proper alignment. Use established safety practices when working near underground or overhead utilities. Consult the appropriate utility company before beginning work.

- 3.1. **Fabrication.** Fabricate sign supports in accordance with Item 441, "Steel Structures." Ensure all components fit properly.

Verify the length of each post for each sign before fabrication to meet field conditions and sign-mounting heights shown on the plans.

Hot-dip galvanize fabricated parts in accordance with Item 445, "Galvanizing." Punch or drill any holes in steel parts or members before galvanizing. Repair galvanizing for any steel part or member damaged during assembly, transit, erection; or for any steel part or member welded, when permitted, after galvanizing. Perform all galvanizing repairs in accordance with Section 445.3.5., "Repairs."

- 3.2. **Installation.** Locate and install sign supports as shown on the plans, unless directed to shift the sign supports within design guidelines to secure a more desirable location or avoid conflict with utilities and underground appurtenances. Stake sign support locations for verification by the Engineer.
- Install stub posts of the type, spacing, orientation, and projection shown on the plans. Remove and replace posts damaged during installation at the Contractor's expense.
- Connect the upper post sections to the stub post sections as shown on the plans. Torque connection bolts as shown on the plans.
- Attach signs to supports in accordance with the plans and pertinent Items.
- 3.3. **Relocation.** Reuse the existing signs as required unless otherwise shown on the plans. Furnish and install new stub posts in new foundations for relocated sign assemblies. Erect the new supports on the new stub posts, and attach the existing signs to the supports in accordance with the plans and pertinent Items. Remove existing foundations to be abandoned in accordance with Section 644.3.4., "Removal."
- 3.4. **Removal.** Remove abandoned concrete foundations to 2 ft. below finish grade unless otherwise shown on the plans. Cut off and remove steel protruding from the remaining concrete. Backfill the remaining hole with material equal in composition and density to the surrounding area. Replace any surfacing with like material to equivalent condition.
- 3.5. **Handling and Storage.** Handle and store existing signs or portions of signs removed so they are not damaged. Prevent any damage to the various sign assembly components. Replace any portion of the sign damaged by the Contractor designated for reuse or salvage, including messages removed.
- Stockpile all removed sign components that will be reused or become the property of the Department at designated locations. Accept ownership of unsalvageable materials, and dispose of them in accordance with federal, state, and local regulations.
- 3.6. **Cleaning.** Wash the entire sign after installation with a biodegradable cleaning solution acceptable to the sign face materials manufacturer to remove dirt, grease, oil smears, streaks, finger marks, and other foreign materials.

4. MEASUREMENT

This Item will be measured as each small roadside assembly or bridge mounted clearance sign assembly installed, removed, or relocated.

5. PAYMENT

The work performed and materials furnished in accordance with this Item and measured as provided under "Measurement" will be paid for at the unit price bid for "Install Small Roadside Sign Assemblies" of the type specified, "Install Bridge Mounted Clearance Sign Assemblies" of the type specified, "Relocate Small Roadside Sign Assemblies" of the type specified, "Relocate Bridge Mounted Clearance Sign Assemblies" of the type specified, "Remove Small Roadside Sign Assemblies," or "Remove Bridge Mounted Clearance Sign Assemblies."

- 5.1. **Installation.** This price is full compensation for furnishing, fabricating, galvanizing, and erecting the supports; constructing foundations including concrete (when required); furnishing complete signs including sign connections and all hardware; attaching the signs to the supports; preparing and cleaning the signs; and materials, equipment, labor, tools, and incidentals.
- 5.2. **Relocation.** This price is full compensation for removing existing sign assemblies and related materials; furnishing and installing new stub posts and new sign supports; constructing foundations including concrete (when required); and new hardware; reinstallation of signs; preparing and cleaning the signs; salvaging;

disposal of unsalvageable materials; removing existing foundations, backfilling, and surface placement; and materials, equipment, labor, tools, and incidentals.

- 5.3. **Removal.** This price is full compensation for removing existing sign assemblies and related materials; salvaging; disposal of unsalvageable materials; removing existing foundations, backfilling, and surface placement; and materials, equipment, labor, tools, and incidentals.

Item 647

Large Roadside Sign Supports and Assemblies



1. DESCRIPTION

- **Installation.** Furnish, fabricate, and erect steel supports for large roadside signs.
- **Relocation.** Relocate existing large roadside sign assemblies, and furnish and fabricate materials as required.
- **Removal.** Remove existing large roadside sign assemblies.

2. MATERIALS

Furnish all materials unless otherwise shown on the plans. Furnish only new materials. Furnish and fabricate materials that comply with the following Items and details shown on the plans:

- Item 416, "Drilled Shaft Foundations"
- Item 421, "Hydraulic Cement Concrete"
- Item 440, "Reinforcement for Concrete"
- Item 441, "Steel Structures"
- Item 442, "Metal for Structures"
- Item 445, "Galvanizing"

Use material for perforated fuse plates that does not exceed the ultimate tensile strength shown on the plans.

Use galvanized steel, stainless steel, dichromate sealed aluminum, or other materials shown on the plans for bolts, nuts, washers, lock washers, screws, and other sign-assembly hardware. When dissimilar metals are used, select or insulate the metals to prevent corrosion.

3. CONSTRUCTION

Construct foundations for large roadside sign supports and assemblies in accordance with Item 416, "Drilled Shaft Foundations," and the details shown on the plans. Plumb sign supports. Do not spring or rake posts to secure proper alignment. Use established safety practices when working near underground or overhead utilities. Consult with the appropriate utility company before beginning work.

- 3.1. **Fabrication.** Fabricate in accordance with Item 441, "Steel Structures." Ensure all components fit properly.

Verify the length of each post for each sign before fabrication to meet field conditions and sign-mounting heights shown on the plans. Obtain approval for any necessary field fabrication or adjustments.

Hot-dip galvanize fabricated parts in accordance with Item 445, "Galvanizing." Punch or drill any holes in steel parts or members before galvanizing. Repair galvanizing for any steel part or member on which the galvanizing has been damaged during assembly, transit, erection; or for any steel part or member welded when permitted, after galvanizing. Make all galvanizing repairs in accordance with Section 445.3.5., "Repairs."

- 3.2. **Installation.** Locate sign supports as shown on the plans, unless directed to shift the sign supports within design guidelines to secure a more desirable location or avoid conflict with utilities and underground appurtenances. Stake the sign support locations for verification by the Engineer.

Install stub posts of the type and at the spacing, orientation, and projection shown on the plans. Secure the stub posts rigidly in position during concrete placement.

At the Contractor's option, sign supports may be cast in the concrete foundation as a unit. However, if installation is made with the upper post section attached, do not expose the support to traffic until the sign panel is properly affixed, unless otherwise approved.

Connect the upper post sections to the stub post sections as shown on the plans. Ensure a flat washer is positioned on top of the bolt keeper plates between the upper and lower slip base sections, and a flat washer is positioned under the head and nut of each connection bolt. Torque connection bolts as shown on the plans.

Attach signs to supports in accordance with the plans and pertinent Items.

- 3.3. **Relocation.** Reuse the existing supports and shorten or lengthen them as required, unless otherwise shown on the plans. Furnish and install new breakaway stub posts in new foundations for relocated sign assemblies. Erect the supports on the new stub posts and attach the signs to the supports in accordance with the plans and pertinent Items.

Unless otherwise shown on the plans, remove abandoned concrete foundations and replace surfacing in accordance with Section 647.3.4., "Removal."

- 3.4. **Removal.** Remove abandoned concrete foundations including steel to 2 ft. below finish grade, unless otherwise shown on the plans. Cut off and remove steel protruding from the remaining concrete. Backfill the remaining hole with material equal in composition and density to the surrounding area. Replace any surfacing with like material to equivalent condition.

- 3.5. **Handling and Storage.** Handle and store existing signs or portions of signs removed so they are not damaged. Prevent any damage to the various sign assembly components. Replace any portion of the sign damaged by the Contractor designated for reuse or salvage, including messages removed.

Stockpile all removed sign components that will be reused or become the property of the Department at designated locations. Accept ownership of unsalvageable materials and dispose of them in accordance with federal, state, and local regulations.

- 3.6. **Cleaning.** Wash the entire sign after installation with a biodegradable cleaning solution acceptable to the sign face material manufacturers to remove dirt, grease, oil smears, streaks, finger marks, and other foreign materials.

4. MEASUREMENT

Installation will be measured by the pound of large roadside sign support steel. Sign assemblies removed or relocated will be measured by each large roadside sign assembly.

This is a plans quantity measurement Item. The quantity to be paid is the quantity shown in the proposal, unless modified by Article 9.2., "Plans Quantity Measurement." Additional measurements or calculations will be made if adjustments of quantities are required.

5. PAYMENT

This work performed and materials furnished in accordance with this Item and measured as provided under "Measurement" will be paid for at the unit price bid for "Install Large Roadside Sign Supports" of the type specified, "Remove Large Roadside Sign Assemblies," or "Relocate Large Roadside Sign Assemblies."

New drilled shaft foundations will be paid for in accordance with Item 416, "Drilled Shaft Foundations." New signs will be paid for in accordance with Item 636, "Signs."

- 5.1. **Installation.** This price is full compensation for furnishing, fabricating, galvanizing, and erecting the supports and stub posts; furnishing fuse plate and slip base connections; and materials, equipment, labor, tools, and incidentals.
- 5.2. **Relocation.** This price is full compensation for furnishing and installing new stub posts, and new sign supports (when required); removing existing sign assemblies and related materials; modifying existing sign supports; reinstallation of signs and sign supports; preparing and cleaning the signs; hardware; salvaging and disposing of unsalvageable materials; removing existing foundations, backfilling, and surface placement; and materials, equipment, labor, tools, and incidentals.
- 5.3. **Removal.** This price is full compensation for removing existing sign assemblies and related materials; salvaging; disposal of unsalvageable materials; removing existing foundations, backfilling, and surface placement; and materials, equipment, labor, tools, and incidentals.

Item 650

Overhead Sign Supports



1. DESCRIPTION

- **Installation.** Furnish, fabricate, and erect overhead sign supports.
- **Relocation.** Remove and relocate existing overhead sign supports.
- **Removal.** Remove existing overhead sign supports.

2. MATERIALS

Provide new materials that comply with the details shown on the plans, the requirements of this Item, and the pertinent requirements of the following Items:

- Item 416, "Drilled Shaft Foundations"
- Item 421, "Hydraulic Cement Concrete"
- Item 441, "Steel Structures"
- Item 442, "Metal for Structures"
- Item 445, "Galvanizing"
- Item 449, "Anchor Bolts"
- Item 618, "Conduit"

Furnish alloy steel or medium-strength mild steel anchor bolts in accordance with Section 449.2.1., "Bolts and Nuts," unless otherwise shown on the plans. Furnish galvanized steel, non-corroding stainless steel, or dichromate-sealed aluminum brackets, clamps, bolts, and other hardware, in accordance with DMS-7120, "Sign Hardware."

Reuse undamaged components when relocating an existing overhead sign structure. Provide new components to replace any damaged during removal or relocation, in accordance with the Items listed in this Article, unless otherwise directed.

3. CONSTRUCTION

- 3.1. **Alternate Design.** Alternate designs of monotube overhead sign supports are not permitted. The Department will consider alternate designs for cantilevered-truss type overhead sign support columns that meet the requirements of this specification and the plans.
- Submit design calculations and a list of proposed materials, including anchor bolts, before submitting shop drawings. Computer-generated design parameters and calculations are not acceptable unless accompanied by the appropriate supporting documentation.
 - Determine the size of pipe to be used for the column from the appropriate Cantilever Overhead Sign Supports (COSS) or High Level Cantilever Overhead Sign Supports (HCOSS) standard plan tables for the height and span specified on the plans.
 - Determine the maximum design parameters from the COSS or HCOSS standard plan tables for that size of pipe.
 - Ensure alternate designs meet or exceed these maximum design parameters.
 - Provide top column dimensions compatible with the sign truss mounting details.
 - Ensure bottom diameter of the column is compatible with foundation details.
 - Limit welds to 2 longitudinal seam welds per column.

- Provide full penetration longitudinal seam welds within 6 in. of circumferential welds, and 85% minimum penetration seam welds at other column locations.
- Provide longitudinal seam weld and fit-up that will minimize acid entrapment during later galvanizing.

- 3.2. **Shop Drawings.** Electronically submit shop drawings for overhead sign supports in accordance with Item 441, "Steel Structures." Include details for anchor bolts, highway and dynamic message sign sizes and positions, walkways, and other required attachments on shop drawings.

Submit only 1 drawing for 2 or more supports of identical design and dimensions. Submit shop drawings to the Bridge Division, unless otherwise shown on the plans.

- 3.3. **Fabrication.** Fabricate and weld in accordance with Item 441, "Steel Structures," AWS D1.1, *Structural Welding Code—Steel*; and the requirements of this Item.

Fabrication plants that produce overhead sign support structures must be approved in accordance with DMS-7380, "Steel Non-Bridge Member Fabrication Plant Qualification." The Construction Division maintains a list of approved overhead sign support structure fabrication plants.

For cantilevered-truss type overhead sign support columns with diameters exceeding 30 in., one circumferential weld splice is permitted per column. Locate the splice at the height of 1/2 the column length. Provide mounting channels for the installation of traffic control devices unless otherwise shown on the plans.

Permanently mark sign support base plates with the fabrication plant's insignia or trademark. For monotube type supports, place the mark on the base plate adjacent to the hand hole access compartment.

Conformance to plans and other approved drawings does not relieve the Contractor of responsibility for proper fit of components.

- 3.4. **Galvanizing.** Punch or drill permitted holes in steel parts or members before galvanizing. Hot-dip galvanize all fabricated parts in accordance with Item 445, "Galvanizing."

- 3.5. **Galvanizing Repair.** Repair galvanizing for steel parts or members damaged in assembly, transit, or erection; for permitted field-drilled holes; or for steel parts or members welded after galvanizing in accordance with the pertinent requirements of Section 445.3.5., "Repairs."

- 3.6. **Installation.** Stake sign support locations for verification by the Engineer. Install overhead sign support structures at verified locations.

Use established industry and utility safety practices when erecting sign supports near overhead or underground utilities. Consult with appropriate utility companies before beginning work.

Construct concrete overhead sign support columns, spans, or both, as shown on the plans and in accordance with Item 420, "Concrete Substructures."

Construct foundations for new overhead sign supports in accordance with Item 416, "Drilled Shaft Foundations," and the details shown on the plans. Orient anchor bolts as shown on the plans. Cap conduit before concrete placement. Ensure the anchor bolt and template assembly is held in position during concrete placement. Use bracing attached to the upper template to ensure conduit is held in place during concrete placement. Remove top template after the concrete achieves initial set.

Erect structures after foundation concrete has attained its design strength as required on the plans and Item 421, "Hydraulic Cement Concrete." Coat anchor bolt threads and tighten anchor bolts in accordance with Item 449, "Anchor Bolts." Ensure that the structure is plumb. Do not use springing or raking of columns, towers, or anchor bolts to achieve plumb.

Tack weld each anchor bolt nut to its washer in 2 places and tack weld each washer to the base plate in 2 places after the overhead sign support has been plumbed and all nuts are tight. Tack weld in accordance with Item 441, "Steel Structures," AWS D1.1, *Structural Welding Code—Steel*; and the requirements of this Item. Do not weld components to the bolt. Repair galvanizing damage on bolts, nuts, and washers after tack welding in accordance with Section 445.3.5., "Repairs." Do not grout between the base plate and foundation.

Ensure sign faces are vertical.

- 3.7. **Relocation.** Disconnect and isolate electrical power supplies before removing the structure. Remove existing overhead sign support structures as directed. Ensure the structures or attached components suffer no undue stress or damage. Signs, sign walkways, mounting brackets, etc., may be left on the structures, unless otherwise shown on the plans or as directed. Repair or replace damaged components as directed.

Remove abandoned concrete foundations and replace surfacing in accordance with Section 650.3.8., "Removal," unless otherwise shown on the plans.

Move existing overhead sign supports to locations shown on the plans or as directed. Construct foundations for relocated overhead sign supports in accordance with Item 416, "Drilled Shaft Foundations," and the details shown on the plans. Install existing structures on new foundations in accordance with Section 650.3.6., "Installation."

Never reuse or replace lighting materials. Reuse other existing components, with the exception of conductors, unless otherwise directed. Accept ownership of unsalvageable materials and dispose of in accordance with federal, state, and local regulations.

- 3.8. **Removal.** Disconnect and isolate electrical power supplies before removing the structure. Remove sign panels, walkways, lighting fixtures, lighting brackets, ballast boxes, and other accessories from overhead sign supports. Remove and store items designated for reuse or salvage at locations shown on the plans or as directed. Store sign panels above the ground in a vertical position. Accept ownership of unsalvageable materials and dispose of in accordance with federal, state, and local regulations.

Remove abandoned concrete foundations, including steel, to 2 ft. below finished grade unless otherwise shown on the plans. Cut off and remove steel protruding from the remaining concrete. Backfill with material equal in composition and density to the surrounding area, and replace surfacing with like material to an equivalent condition.

4. MEASUREMENT

This Item will be measured as each overhead sign support installed, relocated, or removed.

5. PAYMENT

The work performed and materials furnished in accordance with this Item and measured as provided under "Measurement" will be paid for at the unit price bid for "Install Overhead Sign Supports" of the type and span lengths specified, "Relocate Existing Overhead Sign Supports," and "Remove Overhead Sign Supports." The span lengths will be the design span lengths shown on the plans rounded up to the next 5-ft. increment.

New drilled shaft foundations will be paid for under Item 416, "Drilled Shaft Foundations." New concrete columns and spans will be paid for under Item 420, "Concrete Substructures." New signs will be paid for under Item 636, "Signs." New sign walkways will be paid for under Item 654, "Sign Walkways."

- 5.1. **Installation.** This price is full compensation for furnishing, fabricating, galvanizing, assembling, and erecting the overhead sign supports; furnishing and placing anchor bolts, nuts, washers, and templates; furnishing and placing conduit, ground rods, and wiring; and materials, equipment, labor, tools, and incidentals.

- 5.2. **Relocation.** This price is full compensation for removing overhead sign supports; removing existing foundations; backfilling and surface placement; storing the components to be reused or salvaged; disposal of unsalvageable materials; furnishing, fabricating, and installing required new components including anchor bolts, nuts, washers, and templates; placing and securing sign supports on new foundations; furnishing and placing conduit, ground rods, and wiring; loading and hauling; and materials, equipment, labor, tools, and incidentals.
- 5.3. **Removal.** This price is full compensation for removing overhead sign support components; removing the foundations; storing the components to be reused or salvaged; disposal of unsalvageable materials; backfilling and surface placement; loading and hauling; and materials, equipment, labor, tools, and incidentals.

Item 654

Sign Walkways



1. DESCRIPTION

- **Installation.** Furnish, fabricate, and erect sign walkways.
- **Removal.** Remove sign walkways.

2. MATERIALS

Provide materials and construct sign walkways and handrails in accordance with the details shown on the plans, the requirements of this Item, and the pertinent requirements of the following Items:

- Item 441, "Steel Structures"
- Item 445, "Galvanizing"

3. CONSTRUCTION

- 3.1. **Standard Designs.** Provide sign walkways as shown on the plans. Electronically submit shop drawings in accordance with Item 441, "Steel Structures." Submit shop drawings for sign walkways with shop drawings for overhead sign supports. Electronically submit separate shop drawings for sign walkways when installing sign walkways on existing overhead sign supports. Walkways of identical design and dimensions require only a single shop drawing submission. Electronically submit shop drawings to the Bridge Division unless otherwise shown on the plans.
- 3.2. **Fabrication.** Fabricate and weld sign walkways in accordance with Item 441, "Steel Structures," the requirements of this Item, and AWS D1.1, *Structural Welding Code—Steel*.
- Conformance to the plans and other approved drawings does not relieve the Contractor of the responsibility for proper fit of components.
- 3.3. **Galvanizing.** Hot-dip galvanize all fabricated parts in accordance with Item 445, "Galvanizing." Punch or drill permitted holes in steel parts or members before galvanizing. Repair galvanizing for any steel part or member damaged in assembly, transit, or erection or for any steel part or member welded when permitted after galvanizing. Make all galvanizing repairs in accordance with Item 445, "Galvanizing."
- 3.4. **Delivery and Installation.** Deliver each sign walkway as a complete unit or with sub-assemblies marked for field assembly. Install all fittings and hardware, or package all parts together with their associated major components during shipment. Erect the sign walkway in accordance with the details shown on the plans.
- 3.5. **Removal.** Remove sign walkways without damaging materials, and salvage them when indicated on the plans. Stockpile salvaged materials at the location shown on the plans and as directed. Accept ownership of unsalvageable materials, and dispose of them in accordance with federal, state, and local regulations.

4. MEASUREMENT

This Item will be measured by the foot installed or each sign walkway removed.

This is a plans quantity measurement Item. The quantity to be paid for is the quantity shown in the proposal, unless modified by Article 9.2., "Plans Quantity Measurement." Additional measurements or calculations will be made if adjustments of quantities are required.

5. PAYMENT

The work performed and materials furnished in accordance with this Item and measured as provided under "Measurement" will be paid for at the unit price bid for "Sign Walkways" of the types and widths specified or for "Remove Sign Walkways."

- 5.1. **Installation.** This price is full compensation for furnishing, fabricating, galvanizing, assembling, and erecting sign walkways; furnishing and placing required handrails, including connections, latches, plates, bolts, nuts, and washers; and materials, equipment, labor, tools, and incidentals.
- 5.2. **Removal.** This price is full compensation for removing various components; stockpiling; disposal of unsalvageable materials; and materials, equipment, labor, tools, and incidentals.

Item 656

Foundations for Traffic Control Devices



1. DESCRIPTION

Construct concrete foundations for small roadside signs, traffic signal controllers, pedestal poles, roadside flashing beacon assemblies, electrical services, and other small traffic control devices.

2. MATERIALS

Ensure materials and construction methods conform to the requirements of this Item and the pertinent requirements of the following Items:

- Item 400, "Excavation and Backfill for Structures"
- Item 416, "Drilled Shaft Foundations"
- Item 420, "Concrete Substructures"
- Item 421, "Hydraulic Cement Concrete"
- Item 432, "Riprap"
- Item 440, "Reinforcement for Concrete"
- Item 441, "Steel Structures"
- Item 442, "Metal for Structures"
- Item 445, "Galvanizing"
- Item 447, "Structural Bolting"
- Item 449, "Anchor Bolts"
- Item 618, "Conduit"

Use Class A concrete for non-reinforced drilled shafts. Use Class C concrete for reinforced drilled shafts. Use Class B concrete or polymer concrete composed of borosilicate glass fiber, catalyzed polyester resin, and aggregate for traffic signal controller foundations. Use drilled shaft or galvanized steel screw-in type foundations for roadside flashing beacon assemblies.

Use reinforcing steel when required.

3. CONSTRUCTION

Stake and install foundations as shown on the plans. The Engineer may shift the foundation locations within design guidelines where necessary to secure a more desirable location or avoid conflict with utilities. Use established industry and utility safety practices when working near underground or overhead utilities. Consult the appropriate utility before beginning work.

Hold anchor bolts in place with templates during concrete placement. Hold embedded items such as conduit or other hardware in place during concrete placement with templates or other approved means. Cap conduits before placing concrete. Ream conduit to remove burrs and sharp edges. Install bell ends or bushings on the conduit.

Carefully align foundation, posts, and anchor bolts. Do not spring or rake posts or anchor bolts.

Remove the top template after concrete has achieved initial set. Keep forms and other bracing intact until the concrete has cured at least one curing day.

Allow concrete for pedestal poles and roadside flashing beacon assemblies to cure at least 7 days before placing bases and poles on the foundation unless otherwise permitted in writing.

Allow concrete for traffic signal controller foundations and small roadside signs to cure at least 4 days before placing cabinets and posts on the foundation unless otherwise permitted.

Provide an ordinary surface finish to the concrete foundation extending above ground in accordance with Section 420.4.13., "Ordinary Surface Finish."

Place concrete riprap around the foundation in accordance with the plans.

Backfill disturbed surface with material equal in composition and density to the surrounding area. Replace surfacing material with similar material to an equivalent condition.

4. MEASUREMENT AND PAYMENT

The work performed, materials furnished, equipment, labor, tools, and incidentals will not be measured or paid for directly but will be subsidiary to pertinent items.

Item 658

Delineator and Object Marker Assemblies



1. DESCRIPTION

- **Installation.** Install delineator or object maker assembly.
- **Removal.** Remove delineator or object marker assembly.

2. MATERIALS

Furnish only new materials in accordance with details shown on the plans unless otherwise directed. The Engineer will sample in accordance with Tex-725-I or Tex-737-I.

2.1. **Delineator and Object Marker Assemblies.** Fabricate in accordance with the following:

- DMS-8600, "Delineators, Object Markers, and Barrier Reflectors."
- DMS-4400, "Flexible Delineator and Object Marker Posts (Embedded and Surface-Mount Types)."

2.2. **Wing Channel Post.** Furnish material of the size shown on the plans. Supply a notarized original of the Form D-9-USA-1 (Department Form 1818) with supporting mill test report certifying that the base metal is in accordance with the following:

- ASTM A1011, SS Grade 50.
- ASTM A499.

Galvanize material in accordance with Item 445, "Galvanizing."

3. CONSTRUCTION

3.1. **Installation.** Locate delineators and object markers as shown on the plans or as directed.

Locate barrier reflectors as shown on the plans or as directed, and install in accordance with manufacturers recommendations.

Install winged channel post and flexible delineator posts to allow the reflector units and reflectorized panels to be installed at the specified height and orientation. Align post as shown or as directed.

Drive post plumb using a driving cap to prevent visible cross-section dimension distortion. Drill or drive a pilot hole when post cannot be driven without visibly distorting the cross-section dimension. Backfill pilot holes thoroughly by tamping in 6-in. lifts to grade.

Install surface-mount and other types of delineators and object markers in accordance with details shown on the plans.

Repair damaged galvanizing in accordance with Section 445.3.5., "Repairs." Install reflector units on wing channel posts after the posts have been erected.

3.2. **Removal.** Remove post assemblies without damaging materials and salvage when indicated on the plans. Remove post to a minimum of 6 in. below finish grade. Stockpile salvaged materials at the location shown on the plans or as directed. Accept ownership of unsalvageable materials and dispose of in accordance with federal, state, and local requirements.

4. MEASUREMENT

Installation will be measured by each delineator or object marker assembly installed. When removal is specified on the plans to be a pay item, it will be measured by each delineator or object marker assembly removed.

This is a plans quantity measurement item. The quantity to be paid for is shown in the proposal unless modified by Article 9.2., "Plans Quantity Measurement." Additional measurements or calculations will be made if adjustments of quantities are required.

5. PAYMENT

The work performed and materials furnished in accordance with this item and measured as provided under "Measurement" will be paid for at the unit price bid for "Install Delineator Assemblies" or "Install Object Marker Assemblies" of the types and colors specified and for "Remove Delineator or Object Marker Assemblies."

5.1. **Installation.** This price is full compensation for furnishing and fabricating when required, and installing and mounting the delineator or object marker assemblies including posts, adhesive or pads for surface mount assemblies, back plates, reflector units, fastening plates, brackets, bolts, nuts, and washers; and materials, equipment, labor, tools, and incidentals.

5.2. **Removal.** Unless otherwise shown on the plans, removal will not be paid for directly but is subsidiary to bid items of the Contract.

When removal is shown on the plans as a bid item, this price is full compensation for removal and disposal of delineator and object marker assemblies and for materials, equipment, labor, tools, and incidentals.

Item 662

Work Zone Pavement Markings



1. DESCRIPTION

Furnish, place, and maintain work zone pavement markings.

2. MATERIALS

Provide thermoplastic, paint and beads, raised pavement markers (RPMs), prefabricated pavement markings, temporary flexible reflective roadway marker tabs, or other approved materials for work zone pavement markings.

Supply materials meeting:

- DMS-4200, "Pavement Markers (Reflectorized),"
- DMS-4300, "Traffic Buttons,"
- DMS-8200, "Traffic Paint,"
- DMS-8220, "Hot Applied Thermoplastic,"
- DMS-8240, "Permanent Prefabricated Pavement Markings,"
- DMS-8241, "Temporary (Removable) Prefabricated Pavement Markings,"
- DMS-8242, "Temporary Flexible, Reflective Roadway Marker Tabs," and
- DMS-8290, "Glass Traffic Beads."

2.1. **Nonremovable Markings.** Use hot-applied thermoplastic or permanent prefabricated pavement markings for nonremovable markings. Paint and beads or other materials are not allowed for nonremovable markings unless shown on the plans.

2.2. **Removable and Short-Term Markings.** Use RPMs, removable prefabricated pavement markings, temporary flexible reflective roadway marker tabs, or other approved materials for removable and short-term markings. Do not use hot-applied thermoplastic or traffic paint for removable markings. Use removable prefabricated pavement markings on the final pavement surface when the plans specify removable markings.

3. CONSTRUCTION

Apply pavement markings in accordance with the following Items.

- Item 666, "Retroreflectorized Pavement Markings"
- Item 668, "Prefabricated Pavement Markings"
- Item 672, "Raised Pavement Markers"

3.1. **Placement.** Install longitudinal markings on pavement surfaces before opening to traffic. Maintain lane alignment traffic control devices and operations until markings are installed. Install markings in proper alignment in accordance with the TMUTCD and as shown on the plans. Short-term markings will be allowed when standard markings (removable or nonremovable) cannot be placed before opening to traffic, if shown on the plans or directed.

When short-term markings are allowed for opening to traffic, place standard longitudinal markings no later than 14 calendar days after the placement of the surface. When inclement weather prohibits placement of markings, the 14-day period may be extended until weather permits proper application.

Place standard longitudinal markings no sooner than 3 calendar days after the placement of a surface treatment, unless otherwise shown on the plans.

Apply thermoplastic markings to a minimum thickness of 0.060 in. (60 mils). When paint and beads are allowed, apply to a minimum dry thickness of 0.012 in. (12 mils).

Place short-term markings in proper alignment with the location of the final pavement markings. Remove and replace short-term markings not in alignment at the Contractor's expense.

For removable placements, use of RPMs to simulate longitudinal markings is at the Contractor's option. Use side-by-side RPMs to simulate longitudinal lines wider than 4 in. Do not use RPMs for words, symbols, shapes, or diagonal or transverse lines.

- 3.2. **Marking Removal.** Remove markings that conflict with succeeding markings in accordance with Item 677, "Eliminating Existing Pavement Markings and Markers." Remove short-term markings that interfere or conflict with final marking placement immediately before placing final pavement markings, unless otherwise directed. Remove the remainder of the short-term markings before final acceptance.

Remove all temporary markings with minimal damage to the roadway to the satisfaction of the Engineer.

- 3.3. **Performance Requirements.** Ensure all markings are visible from a distance at least 300 ft. in daylight conditions and at least 160 ft. in nighttime conditions when illuminated by automobile low-beam headlights. Determine visibility distances using an automobile traveling on the roadway under dry conditions.

Maintain the markings for 30 calendar days after installation. The end of the 30-day maintenance period does not relieve the Contractor from the performance deficiencies requiring corrective action identified during the 30-day period. Remove and replace markings at the Contractor's expense if they fail to meet the requirements of this Item during the 30-day period. The 30-calendar day performance requirement will begin again after replacement of the markings.

Ensure daytime and nighttime reflected color of the markings are distinctly white or yellow. Ensure markings exhibit uniform retroreflective characteristics.

4. MEASUREMENT

This Item will be measured by the foot or each word, shape, symbol, or temporary flexible reflective roadway marker tab. Each stripe will be measured separately. RPMs used to simulate a marking will be measured by the foot of marking or each RPM.

This is a plans quantity measurement Item. The quantity to be paid is the quantity shown in the proposal, unless modified by Article 9.2., "Plans Quantity Measurement." Additional measurements or calculations will be made if adjustments of quantities are required.

5. PAYMENT

The work performed and materials furnished in accordance with this Item and measured as provided under "Measurement" will be paid for at the unit price bid for "Work Zone Pavement Markings" of the type and color specified and the shape, width, and size specified as applicable. This price is full compensation for furnishing, placing, maintaining, and removing work zone pavement markings and for materials, equipment, labor, tools, and incidentals.

Elimination of nonremovable markings will be paid for under Item 677, "Eliminating Existing Pavement Markings and Markers." Removal of short-term and removable markings will not be paid for directly but will be subsidiary to this Item.

Type II work zone pavement markings (paint and beads) used as a sealer for Type I pavement markings (thermoplastic) will be paid for under this Item.

Item 666

Retroreflectorized Pavement Markings



1. DESCRIPTION

Furnish and place retroreflectorized, non-retroreflectorized (shadow) and profile pavement markings.

2. MATERIALS

2.1. **Type I Marking Materials.** Furnish in accordance with DMS-8220, "Hot Applied Thermoplastic."

Furnish pavement marking material used for Type I profile markings and shadow markings that have been approved by the Construction Division, and in accordance with DMS-8220, "Hot Applied Thermoplastic."

2.2. **Type II Marking Materials.** Furnish in accordance with DMS-8200, "Traffic Paint."

2.3. **Glass Traffic Beads.** Furnish drop-on glass beads in accordance with DMS-8290, "Glass Traffic Beads" or as approved. Furnish a double-drop of Type II and Type III drop-on glass beads where each type bead is applied separately in equal portions (by weight), unless otherwise approved. Apply the Type III beads before applying the Type II beads.

2.4. **Labeling.** Use clearly marked containers that indicate color, mass, material type, manufacturer, and batch number.

3. EQUIPMENT

3.1. **General Requirements.** Use equipment that:

- is maintained in satisfactory condition,
- meets or exceeds the requirements of the National Board of Fire Underwriters and the Texas Railroad Commission for this application,
- applies beads by an automatic bead dispenser attached to the pavement marking equipment in such a manner that the beads are dispensed uniformly and almost instantly upon the marking as the marking is being applied to the road surface. The bead dispenser must have an automatic cut-off control, synchronized with the cut-off of the pavement marking equipment,
- has an automatic cut-off device with manual operating capabilities to provide clean, square marking ends,
- is capable of producing the types and shapes of profiles specified, and
- can provide continuous mixing and agitation of the pavement marking material. The use of pans, aprons, or similar appliances which the die overruns will not be permitted for longitudinal striping applications.

Provide a hand-held thermometer capable of measuring the temperature of the marking material when applying Type I material.

When pavement markings are required to meet minimum retroreflectivity requirements on the plans:

- Use a mobile retroreflectometer approved by the Construction Division and certified by the Texas A&M Transportation Institute Mobile Retroreflectometer Certification Program.
- Use a portable retroreflectometer that:
 - uses 30-meter geometry and meets the requirements described in ASTM E1710;
 - has either an internal global positioning system (GPS) or the ability to be linked with an external GPS with a minimum accuracy rating of 16 ft. 5 in., in accordance with the circular error probability

(CEP) method (CEP is the radius of the circle with its origin at a known position that encompasses 50% of the readings returned from the GPS instrument);

- can record and print the GPS location and retroreflectivity reading for each location where readings are taken.

3.2. **Material Placement Requirements.** Use equipment that can place:

- at least 40,000 ft. of 4-in. solid or broken non-profile markings per working day at the specified thickness;
- at least 15,000 ft. of solid or broken profile pavement markings per working day at the specified thickness;
- linear non-profile markings up to 8 in. wide in a single pass;
- non-profile pavement markings other than solid or broken lines at an approved production rate;
- a centerline and no-passing barrier-line configuration consisting of 1 broken line and 2 solid lines at the same time to the alignment, spacing, and thickness for non-profile pavement markings shown on the plans;
- solid and broken lines simultaneously;
- white line from both sides;
- lines with clean edges, uniform cross-section with a tolerance of $\pm 1/8$ in. per 4 in. width, uniform thickness, and reasonably square ends;
- skip lines between 10 and 10-1/2 ft., a stripe-to-gap ratio of 10 to 30, and a stripe-gap cycle between 39-1/2 ft. and 40-1/2 ft., automatically;
- beads uniformly and almost instantly on the marking as the marking is being applied;
- beads uniformly during the application of all lines (each line must have an equivalent bead yield rate and embedment); and
- double-drop bead applications using both Type II and Type III beads from separate independent bead applicators, unless otherwise approved by the Engineer.

4. CONSTRUCTION

Place markings before opening to traffic unless short-term or work zone markings are allowed.

4.1. **General.** Obtain approval for the sequence of work and estimated daily production. Minimize interference to roadway operations when placing markings on roadways open to traffic. Use traffic control as shown on the plans or as approved. Protect all markings placed under open-traffic conditions from traffic damage and disfigurement.

Establish guides to mark the lateral location of pavement markings as shown on the plans or as directed, and have guide locations verified. Use material for guides that will not leave a permanent mark on the roadway.

Apply markings on pavement that is completely dry and passes the following tests:

- **Type I Marking Application**—Place a sample of Type I marking material on a piece of tarpaper placed on the pavement. Allow the material to cool to ambient temperature, and then inspect the underside of the tarpaper in contact with the pavement. Pavement will be considered dry if there is no condensation on the tarpaper.
- **Type II Marking Application**—Place a 1-sq. ft. piece of clear plastic on the pavement, and weight down the edges. The pavement is considered dry if, when inspected after 15 min., no condensation has occurred on the underside of the plastic.

Apply markings:

- that meet the requirements of Tex-828-B,

- that meet minimum retroreflectivity requirements when specified on the plans (applies to Type I markings only),
- using widths and colors shown on the plans,
- at locations shown on the plans,
- in proper alignment with the guides without deviating from the alignment more than 1 in. per 200 ft. of roadway or more than 2 in. maximum,
- without abrupt deviations,
- free of blisters and with no more than 5% by area of holes or voids,
- with uniform cross-section, density and thickness,
- with clean and reasonably square ends,
- that are retroreflectorized with drop-on glass beads, and
- using personnel skilled and experienced with installation of pavement markings.

Remove all applied markings that are not in alignment or sequence as stated on the plans, or in the specifications, at the Contractor's expense in accordance with Item 677, "Eliminating Existing Pavement Markings and Markers," except for measurement and payment.

- 4.2. **Surface Preparation.** Prepare surfaces in accordance with this Section unless otherwise shown on the plans.
- 4.2.1. **Cleaning for New Asphalt Surfaces and Retracing of All Surfaces.** Air blast or broom the pavement surface for new asphalt surfaces (less than 3 years old) and for retracing of all surfaces to remove loose material, unless otherwise shown on the plans. A sealer for Type I markings is not required unless otherwise shown on the plans.
- 4.2.2. **Cleaning for Old Asphalt and Concrete Surfaces (Excludes Retracing).** Clean old asphalt surfaces (more than 3 years old) and all concrete surfaces in accordance with Item 678, "Pavement Surface Preparation for Markings," to remove curing membrane, dirt, grease, loose and flaking existing construction markings, and other forms of contamination.
- 4.2.3. **Sealer for Type I Markings.** Apply a pavement sealer to old asphalt surfaces (more than 3 years old) and to all concrete surfaces before placing Type I markings on locations that do not have existing markings, unless otherwise approved. The pavement sealer may be either a Type II marking or an acrylic or epoxy sealer as recommended by the Type I marking manufacturer unless otherwise shown on the plans. Follow the manufacturer's directions for application of acrylic or epoxy sealers. Clean sealer that becomes dirty after placement by washing or in accordance with Section 666.4.2.1., "Cleaning for New Asphalt Surfaces and Retracing of All Surfaces," as directed. Place the sealer in the same configuration and color (unless clear) as the Type I markings unless otherwise shown on the plans.
- 4.3. **Application.** Apply markings during good weather unless otherwise directed. If markings are placed at Contractor option when inclement weather is impending and the markings are damaged by subsequent precipitation, the Contractor is responsible for all required replacement costs.
- 4.3.1. **Type I Markings.** Place the Type I marking after the sealer cures. Apply within the temperature limits recommended by the material manufacturer. Flush the spray head if spray application operations cease for 5 min or longer by spraying marking material into a pan or similar container until the material being applied is at the recommended temperature.
- Apply on clean, dry pavements passing the moisture test described in Section 666.4.1., "General," and with a surface temperature above 50°F when measured in accordance with Tex-829-B.
- 4.3.1.1. **Non-Profile Pavement Markings.** Apply Type I non-profile markings with a minimum thickness of:
- 0.100 in. (100 mils) for new markings and retracing water-based markings on surface treatments involving Item 316, "Seal Coat,"

- 0.060 in. (60 mils) for retracing on thermoplastic pavement markings, or
- 0.090 in. (90 mils) for all other Type I markings.

The maximum thickness for Type I non-profile markings is 0.180 in. (180 mils). Measure thickness for markings in accordance with Tex-854-B using the tape method.

4.3.1.2. **Profile Pavement Markings.** Apply Type I profile markings with a minimum thickness of:

- 0.060 in. (60 mil) for edgeline markings, or
- 0.090 in. (90 mil) for gore and centerline/no-passing barrier line markings.

In addition, at a longitudinal spacing indicated on the plans, the markings must be profiled in a vertical manner such that the profile is transverse to the longitudinal marking direction. The profile must not be less than 0.30 in. (300 mil) nor greater than 0.50 in. (500 mil) in height when measured above the normal top surface plane of the roadway. The transverse width of the profile must not be less than 3.25 in., and the longitudinal width not less than 1 in., when measured at the top surface plane of the profile bar. The profile may be either a 1 or 2 transverse bar profile. When the 2 transverse bar profile is used, the spacing between the bases of the profile bars must not exceed 0.50 in. The above transverse bar width is for each 4 in. of line width.

4.3.2. **Type II Markings.** Apply on surfaces with a minimum surface temperature of 50°F. Apply at least 20 gal. per mile on concrete and asphalt surfaces and at least 22 gal. per mile on surface treatments for a solid 4-in. line. Adjust application rates proportionally for other widths. When Type II markings are used as a sealer for Type I markings, apply at least 15 gal. per mile using Type II drop-on beads.

4.3.3. **Bead Coverage.** Provide a uniform distribution of beads across the surface of the stripe for Type I and Type II markings, with 40% to 60% bead embedment.

4.4. **Retroreflectivity Requirements.** When specified on the plans, Type I markings must meet the following minimum retroreflectivity values for edgeline markings, centerline or no passing barrier-line, and lane lines when measured any time after 3 days, but not later than 10 days after application:

- White markings: 250 millicandelas per square meter per lux (mcd/m²/lx)
- Yellow markings: 175 mcd/m²/lx

4.5. **Retroreflectivity Measurements.** Use a mobile retroreflectometer for projects requiring minimum retroreflectivity requirements to measure retroreflectivity for Contracts totaling more than 200,000 ft. of pavement markings, unless otherwise shown on the plans. For Contracts with less than 200,000 ft. of pavement markings or Contracts with callout work, mobile or portable retroreflectometers may be used at the Contractor's discretion.

4.5.1. **Mobile Retroreflectometer Measurements.** Provide mobile measurements averages for every 0.1 miles unless otherwise specified or approved. Take measurements on each section of roadway for each series of markings (i.e., edgeline, center skip line, each line of a double line, etc.) and for each direction of traffic flow. Measure each line in both directions for centerlines on two-way roadways (i.e., measure both double solid lines in both directions and measure all center skip lines in both directions). Furnish measurements in compliance with Special Specification, "Mobile Retroreflectivity Data Collection for Pavement Markings," unless otherwise approved. The Engineer may require an occasional field comparison check with a portable retroreflectometer meeting the requirements listed above to ensure accuracy. Use all equipment in accordance with the manufacturer's recommendations and directions. Inform the Engineer at least 24 hr. before taking any measurements.

A marking meets the retroreflectivity requirements if:

- the combined average retroreflectivity measurement for a one-mile segment meets the minimum retroreflectivity values specified, and
- no more than 30% of the retroreflectivity measurement values are below the minimum retroreflectivity requirements value within the one-mile segment.

The Engineer may accept failing one-mile segments if no more than 20% of the retroreflectivity measurements within that mile segment are below the minimum retroreflectivity requirement value.

The one-mile segment will start from the beginning of the data collection and end after a mile worth of measurements have been taken; each subsequent mile of measurements will be a new segment. Centerlines with 2 stripes (either solid or broken) will result in 2 miles of data for each mile segment. Each centerline stripe must be tested for compliance as a stand-alone stripe.

Restripe at the Contractor's expense with a minimum of 0.060 in. (60 mils) of Type I marking if the marking fails retroreflectivity requirements. Take measurements every 0.1 miles a minimum of 10 days after this second application within that mile segment for that series of markings.

If the markings do not meet minimum retroreflectivity after 10 days of this second application, the Engineer may require removal of all existing markings, a new application as initially specified, and a repeat of the application process until minimum retroreflectivity requirements are met.

- 4.5.2. **Portable Retroreflectometer Measurements.** Take a minimum of 20 measurements for each 1-mi. section of roadway for each series of markings (i.e., edgeline, center skip line, each line of a double line, etc.) and direction of traffic flow when using a portable reflectometer. Measure each line in both directions for centerlines on two-way roadways (i.e., measure both double solid lines in both directions and measure all center skip lines in both directions). The spacing between each measurement must be at least 100 ft. The Engineer may decrease the mileage frequency for measurements if the previous measurements provide satisfactory results. The Engineer may require the original number of measurements if concerns arise.

Restripe once at the Contractor's expense with a minimum of 0.060 in. (60 mils) of Type I marking material if the average of these measurements fails. Take a minimum of 10 more measurements after 10 days of this second application within that mile segment for that series of markings. Restripe again at the Contractor's expense with a minimum of 0.060 in. (60 mils) of Type I marking material if the average of these measurements fall below the minimum retroreflectivity requirements. If the markings do not meet minimum retroreflectivity after this third application, the Engineer may require removal of all existing markings, a new application as initially specified, and a repeat of the application process until minimum retroreflectivity requirements are met.

- 4.5.3. **Traffic Control.** Provide traffic control, as required, when taking retroreflectivity measurements after marking application. On low volume roadways (as defined on the plans), refer to the figure, "Temporary Road Closure" in Part 6 of the *Texas Manual on Uniform Traffic Control Devices* for the minimum traffic control requirements. For all other roadways, the minimum traffic control requirements will be as shown on the Traffic Control Plan (TCP) standard sheets TCP (3-1) and TCP (3-2). The lead vehicle will not be required on divided highways. The TCP and traffic control devices must meet the requirements listed in Item 502, "Barricades, Signs, and Traffic Handling." Time restrictions that apply during striping application will also apply during the retroreflectivity inspections except when using the mobile retroreflectometer unless otherwise shown on the plans or approved.

- 4.6. **Performance Period.** All markings must meet the requirements of this specification for at least 30 calendar days after installation. Unless otherwise directed, remove pavement markings that fail to meet requirements, and replace at the Contractor's expense. Replace failing markings within 30 days of notification. All replacement markings must also meet all requirements of this Item for a minimum of 30 calendar days after installation.

5. MEASUREMENT

This Item will be measured by the foot; by each word, symbol, or shape; or by any other unit shown on the plans. Each stripe will be measured separately.

This is a plans quantity measurement item. The quantity to be paid is the quantity shown in the proposal unless modified by Article 9.2., "Plans Quantity Measurement." Additional measurements or calculations will be made if adjustments of quantities are required.

Acrylic or epoxy sealer, or Type II markings when used as a sealer for Type I markings, will be measured by the foot; by each word, symbol, or shape; or by any other unit shown on the plans.

6. PAYMENT

The work performed and materials furnished in accordance with this Item and measured as provided under "Measurement" will be paid for at the unit price bid for "Pavement Sealer" of the size specified, "Retroreflectorized Pavement Markings" of the type and color specified and the shape, width, size, and thickness specified as applicable, "Retroreflectorized Pavement Markings with Retroreflective Requirements" of the types, colors, sizes, widths, and thicknesses specified or "Retroreflectorized Profile Pavement Markings" of the various types, colors, shapes, sizes, and widths specified.

This price is full compensation for application of pavement markings, materials, equipment, labor, tools, and incidentals.

Surface preparation of new concrete and asphalt concrete pavements more than 3 years old, where no stripe exists, will be paid for under Item 678, "Pavement Surface Preparation for Markings." Surface preparation of all other asphalt and old concrete pavement, except for sealing, will not be paid for directly but is subsidiary to this Item.

Work zone pavement markings (Type II, paint and beads) used as a sealer for Type I markings (thermoplastic) will be paid for under Item 662, "Work Zone Pavement Markings."

If the Engineer requires that markings be placed in inclement weather, repair or replacement of markings damaged by the inclement weather will be paid for in addition to the original plans quantity.

Item 668

Prefabricated Pavement Markings



1. DESCRIPTION

Furnish and place retroreflectorized or non-reflectorized (contrast) prefabricated pavement markings.

2. MATERIALS

Furnish prefabricated pavement marking materials in accordance with DMS-8240, "Permanent Prefabricated Pavement Markings."

Furnish prefabricated pavement marking materials used for contrast markings in accordance with DMS-8240, "Permanent Prefabricated Pavement Markings," with the exception that the color requirement for the black contrast portion does not have to meet the color requirements specified for white or yellow markings. Store all materials in a weatherproof enclosure and prevent damage during storage.

3. CONSTRUCTION

3.1. **General.** Obtain approval for the sequence of work and estimated daily production. Remove all waste generated from the jobsite before the end of each working day.

Establish guides to mark the lateral location of pavement markings as shown on the plans or as directed, and have guide locations verified. Use guide material that will not leave a permanent mark on the roadway.

Place pavement markings in alignment with the guides without deviating from the alignment more than 1 in. per 200 ft. of roadway or more than 2 in. maximum and with no abrupt deviations.

3.2. **Placement Limitations.** Do not place Type B pavement-marking materials between September 30 and March 1 unless otherwise directed.

3.2.1. **Moisture.** Apply material to pavement that is completely dry. Pavement will be considered dry if, on a sunny day after 15 min., no condensation occurs on the underside of a 1-sq. ft. piece of clear plastic that has been placed on the pavement and weighted on the edges.

3.2.2. **Temperature.** Follow pavement and ambient air temperature requirements recommended by the material manufacturer. Do not place material when the pavement temperature is below 60°F or above 120°F if the material manufacturer does not establish temperature requirements.

3.3. **Dimensions.** Place markings in accordance with the color, length, width, shape, and configuration shown on the plans. Locate alignment as shown on the plans or as directed.

3.4. **Methods.** Place all materials in accordance with the material manufacturer's instructions, as well as the surface condition, moisture and temperature requirements of this Item, unless otherwise directed.

3.5. **Surface Preparation.** Prepare surface by any approved cleaning method that effectively removes contaminants, loose materials, and conditions deleterious to proper adhesion. Abrasive or water-blast cleaning is not required unless shown on the plans. Blast clean, when required, in accordance with Item 678, "Pavement Surface Preparation for Markings." Prepare surfaces further after cleaning by sealing or priming as recommended by the pavement-marking material manufacturer or as directed. Use adhesive, when required, of the type and quality recommended by the pavement-marking material manufacturer. Do not clean concrete pavement surfaces by grinding.

- 3.6. **Performance Requirements.**
- 3.6.1. **Adhesion.** Ensure markings do not lift, shift, smear, spread, flow, or tear by traffic action.
- 3.6.2. **Appearance.** Ensure markings present a neat, uniform appearance that is free of excessive adhesive, ragged edges, and irregular lines or contours.
- 3.6.3. **Visibility.** Ensure markings have uniform and distinctive retroreflectance when inspected in accordance with Tex-828-B.
- 3.7. **Performance Period.** All markings must meet the requirements of this Item for at least 30 calendar days after installation. Remove and replace all pavement markings that fail to meet requirements at the Contractor's expense unless otherwise directed. Replace failing markings within 30 days of notification. All replacement markings must also meet all requirements of this Item for a minimum of 30 calendar days after installation.

4. MEASUREMENT

This Item will be measured by the foot or by each word, shape, or symbol.

This is a plans quantity measurement Item. The quantity to be paid is the quantity shown in the proposal, unless modified by Article 9.2., "Plans Quantity Measurement." Additional measurements or calculations will be made if adjustments of quantities are required.

5. PAYMENT

The work performed and materials furnished in accordance with this Item and measured as provided under "Measurement" will be paid for at the unit price bid for "Prefabricated Pavement Markings" of the type and color specified and the shape, width, and size specified as applicable. This price is full compensation for cleaning the pavement by any means other than required abrasive or water-blast cleaning or milling; furnishing and placing materials; and equipment, labor, tools, and incidentals.

Abrasive or water-blast cleaning and milling, when shown on the plans, will be paid for under Item 678, "Pavement Surface Preparation for Markings."

Item 672

Raised Pavement Markers



1. DESCRIPTION

Furnish and install raised pavement markers (RPMs).

2. MATERIALS

2.1. **Markers.** Furnish RPMs in accordance with the following Department Material Specifications:

- **Reflectorized Pavement Markers.** DMS-4200, "Pavement Markers (Reflectorized)," types I-A, I-C, I-R, II-A-A, and II-C- R.
- **Traffic Buttons.** DMS-4300, "Traffic Buttons," types I-A, I-C, I-R, II-A-A, II-C- R, W, Y and B. Round or oval unless otherwise specified on the plans.
- **Plowable Reflectorized Pavement Markers.** DMS-4210, "Snowplowable Pavement Markers," types I-A, I-C, I-R, II-A-A, and II-C- R.

The following are descriptions for each type of RPM:

- **Type I-A.** The approach face must retro-reflect amber light. The body, other than the retro-reflective face, must be yellow.
- **Type I-C.** The approach face must retro-reflect white light. The body, other than the retro-reflective face, must be white or silver-white.
- **Type I-R.** The trailing face must retro-reflect red light. The body, other than the retro-reflective face, must be white or silver-white, except for I-R plowable markers which may be black.
- **Type II-A-A.** The 2 retro-reflective faces (approach and trailing) must retro-reflect amber light. The body, other than the retro-reflective faces, must be yellow.
- **Type II-C-R.** Contain 2 retro-reflective faces with an approach face that must retro-reflect white light and a trailing face that must retro-reflect red light. The body, other than the retro-reflective faces, must be white or silver-white.
- **Type W.** Must have a white body and no reflective faces.
- **Type Y.** Must have a yellow body and no reflective faces.
- **Type B.** Must have a black body and no reflective faces.

2.2. **Adhesives.** Furnish adhesives that conform to the following requirements:

- DMS-6100, "Epoxy and Adhesives," Type II—Traffic Marker Adhesives.
- DMS-6130, "Bituminous Adhesive for Pavement Markers."
- The Contractor may propose alternate adhesive materials for consideration and approval.

2.3. **Sampling.** The Engineer will sample in accordance with Tex-729-I.

3. CONSTRUCTION

Remove existing RPMs in accordance with Item 677, "Eliminating Existing Pavement Markings and Markers," except for measurement and payment. Furnish RPMs for each class from the same manufacturer. Prepare all surfaces in accordance with Item 678, "Pavement Surface Preparation for Markings," when shown on the plans. Ensure the bond surfaces are free of dirt, curing compound, grease, oil, moisture, loose or unsound pavement markings, and any other material that would adversely affect the adhesive bond.

Establish pavement marking guides to mark the lateral location of RPMs as shown on the plans and as directed. Do not make permanent marks on the roadway for the guides.

Place RPMs in proper alignment with the guides. Acceptable placement deviations are shown on the plans.

Remove RPMs placed out of alignment or sequence, as shown on the plans or stated in this specification, at Contractor's expense, in accordance with Item 677, "Eliminating Existing Pavement Markings and Markers" (except for measurement and payment).

Use the following adhesive materials for placement of reflectorized pavement markers, and traffic buttons unless otherwise shown on the plans:

- standard or flexible bituminous adhesive for applications on bituminous pavements, and
- epoxy adhesive or flexible bituminous adhesive for applications on hydraulic cement concrete pavements.

Use epoxy adhesive for plowable reflectorized pavement markers.

Apply enough adhesives to:

- ensure that 100% of the bonding area of RPMs is in contact with the adhesive, and
- ensure that RPMs, except for plowable markers, are seated on a continuous layer of adhesive and not in contact with the pavement surface.

Apply adhesives in accordance with manufacturer's recommendations unless otherwise required by this Article. Apply bituminous adhesive only when pavement temperature and RPM temperature are 40°F or higher. Do not heat bituminous adhesive above 400°F. Machine agitate bituminous adhesive continuously before application to ensure even heat distribution.

Machine-mix epoxy adhesive. Apply epoxy adhesive only when pavement temperature is 50°F or higher.

Furnish RPMs free of rust, scale, dirt, oil, grease, moisture, and contaminants that might adversely affect the adhesive bond.

Place RPMs immediately after the adhesive is applied and ensure proper bonding. Do not use adhesives or any other material that impairs the functional retro-reflectivity of the RPMs.

Provide a 30-day performance period that begins the day following written acceptance for each separate location. The date of written acceptance will be the last calendar day of each month for the RPMs installed that month for the completed separate project locations. This written acceptance does not constitute final acceptance.

Replace all missing, broken or non-reflective RPMs. Visual evaluations will be used for these determinations. Upon request, the Engineer will allow a Contractor representative to accompany the Engineer on these evaluations.

The Engineer may exclude RPMs from the replacement provisions of the performance, provided the Engineer determines the failure is a result of causes other than defective material or inadequate installation procedures. Examples of outside causes are extreme wear at intersections, damage by snow or ice removal, and pavement failure.

Replace all missing or non-reflective RPMs identified during the performance period within 30 days after notification. The end of the performance period does not relieve the Contractor from the performance deficiencies requiring corrective action identified during the performance period.

4. MEASUREMENT

This Item will be measured by each RPM.

This is a plans quantity measurement Item. The quantity to be paid is the quantity shown in the proposal, unless modified by Article 9.2., "Plans Quantity Measurement." Additional measurements or calculations will be made if adjustments are required.

5. PAYMENT

The work performed and materials furnished in accordance with this Item and measured as provided under "Measurement" will be paid for at the unit price bid for "Reflectorized Pavement Marker," "Traffic Button," or "Plowable Reflectorized Pavement Marker" of the types specified. This price is full compensation for removing existing markers; furnishing and installing RPMs; and materials, equipment, labor, tools, and incidentals.

No additional payment will be made for replacement of RPMs failing to meet the performance requirements.

Item 677

Eliminating Existing Pavement Markings and Markers



1. DESCRIPTION

Eliminate existing pavement markings and raised pavement markers (RPMs).

2. MATERIALS

Furnish surface treatment materials in accordance with the following Items:

- Item 300, "Asphalts, Oils, and Emulsions"
- Item 302, "Aggregates for Surface Treatments"
- Item 316, "Seal Coat"

Use approved patching materials for repairing damaged surfaces.

Use a commercial abrasive blasting medium capable of producing the specified surface cleanliness. Use potable water when water is required.

3. EQUIPMENT

Furnish and maintain equipment in good working condition. Use moisture and oil traps in air compression equipment to remove all contaminants from the blasting air and prevent the deposition of moisture, oil, or other contaminants on the roadway surface.

4. CONSTRUCTION

Eliminate existing pavement markings and markers on both concrete and asphaltic surfaces in such a manner that color and texture contrast of the pavement surface will be held to a minimum. Remove all markings and markers with minimal damage to the roadway to the satisfaction of the Engineer. Repair damage to asphaltic surfaces, such as spalling, shelling, etc., greater than 1/4 in. deep resulting from the removal of pavement markings and markers. Dispose of markers in accordance with federal, state, and local regulations. Use any of the following methods unless otherwise shown on the plans:

- 4.1. **Surface Treatment Method.** Apply surface treatment material at rates shown on the plans, or as directed. Place a surface treatment a minimum of 2 ft. wide to cover the existing marking. Place a surface treatment, thin overlay, or microsurfacing a minimum of one lane in width in areas where directional changes of traffic are involved or other areas as directed.
- 4.2. **Burn Method.** Use an approved burning method. For thermoplastic pavement markings or prefabricated pavement markings, heat may be applied to remove the bulk of the marking material before blast cleaning. When using heat, avoid spalling pavement surfaces. Sweeping or light blast cleaning may be used to remove minor residue.
- 4.3. **Blasting Method.** Use a blasting method such as water blasting, abrasive blasting, water abrasive blasting, shot blasting, slurry blasting, water-injected abrasive blasting, or brush blasting as approved. Remove pavement markings on concrete surfaces by a blasting method.
- 4.4. **Mechanical Method.** Use any mechanical method except grinding. Flail milling is acceptable in the removal of markings on asphalt and concrete surfaces.

5. MEASUREMENT

This Item will be measured by each word, symbol, or shape eliminated; by the foot of marking eliminated; or by any other unit shown on the plans.

This is a plans quantity measurement Item. The quantity to be paid is the quantity shown in the proposal unless modified by Article 9.2., "Plans Quantity Measurement." Additional measurements or calculations will be made if adjustments of quantities are required.

6. PAYMENT

The work performed and materials furnished in accordance with this Item and measured as provided under "Measurement" will be paid for at the unit price bid for "Eliminating Existing Pavement Markings and Markers" of the type and width as applicable. This price is full compensation for the elimination method used and materials, equipment, tools, labor, and incidentals. Removal of RPMs will not be paid for directly but will be subsidiary to the pertinent bid items.

Item 678

Pavement Surface Preparation for Markings



1. DESCRIPTION

Prepare pavement surface areas before placement of pavement markings and raised pavement markers (RPMs). Item 677, "Eliminating Existing Pavement Markings and Markers," governs removal of existing markings.

2. MATERIALS

Use a commercial abrasive blasting medium capable of producing the specified surface cleanliness. Use potable water, when water is required.

3. EQUIPMENT

Furnish and maintain equipment in good working condition. Use moisture and oil traps in air compression equipment to remove all contaminants from the blasting air and prevent the deposition of moisture, oil, or other contaminants on the roadway surface.

4. CONSTRUCTION

Prepare enough pavement surface for the pavement markings or RPMs shown on the plans. Remove all contamination and loose material. Avoid damaging the pavement surface. Remove loose and flaking material when existing pavement markings are present. Approved pavement surface preparation methods are sweeping, air blasting, flail milling, and blast cleaning unless otherwise specified on the plans.

Air blast concrete pavement surfaces, in addition to the above, after the removal of contamination or existing material and just before placing the stripe. Perform air blasting with a compressor capable of generating compressed air at a minimum of 150 cu. ft. per minute and 100 psi using 5/16 in. or larger hosing.

Contaminants up to 0.5 sq. in. may remain if they are not removed by the following test, performed just before application of markings:

- **Step 1.** Air blast the surface to be tested, to simulate blasting during application of markings.
- **Step 2.** Firmly press a 10-in. long, 2-in. wide strip of monofilament tape onto the surface, leaving approximately 2 in. free.
- **Step 3.** Grasp the free end and remove the tape with a sharp pull.

5. MEASUREMENT

This Item will be measured by the foot for each width specified; by each word, shape, or symbol; or by any other unit except lump sum.

This is a plans quantity measurement Item. The quantity to be paid is the quantity shown in the proposal, unless modified by Article 9.2., "Plans Quantity Measurement." Additional measurements or calculations will be made if adjustments of quantities are required.

6. PAYMENT

The work performed and materials furnished in accordance with this Item and measured as provided under "Measurement" will be paid for at the unit price bid for "Pavement Surface Preparation for Markings" of the type and width as applicable. This price is full compensation for the cleaning method used, materials, equipment, labor, tools, and incidentals.

Item 680

Highway Traffic Signals



1. DESCRIPTION

- **Installation.** Install highway traffic signals.
- **Removal.** Remove, store, and salvage traffic signals.

2. MATERIALS

Ensure electrical materials and construction methods conform to the current NEC and additional local utility requirements.

Furnish new materials. Ensure all materials and construction methods conform to the details shown on the plans, the requirements of this Item, and the pertinent requirements of the following Items:

- Item 610, "Roadway Illumination Assemblies"
- Item 625, "Zinc-Coated Steel Wire Strand"
- Item 627, "Treated Timber Poles"
- Item 636, "Signs"
- Item 656, "Foundations for Traffic Control Devices"

Provide controller assemblies that meet the requirements of DMS-11170, "Fully Actuated, Solid-State Traffic Signal Controller Assembly," and the details shown on the plans.

Provide prequalified controller assemblies from the Department's MPL.

Provide flasher assemblies that meet the requirements of DMS-11160, "Flasher Controller Assembly," and the details shown on the plans.

Provide prequalified flasher assemblies from the Department's MPL.

Sampling and testing of traffic signal controller assemblies will be done in accordance with Tex-1170-T.

3. CONSTRUCTION

3.1. **Installation.** Install traffic signal controller foundations in accordance with Item 656, "Foundations for Traffic Control Devices."

3.1.1. **Electrical Requirements.**

3.1.1.1. **Electrical Services.** Make arrangements for electrical services and install and supply materials not provided by the utility company as shown on the plans. Install 120-volt, single-phase, 60-Hz AC electrical service unless otherwise shown on the plans.

3.1.1.2. **Conduit.** Install conduit and fittings of the sizes and types shown on the plans. Conduit of larger diameter size than that shown on the plans may be used with no additional compensation, providing the same diameter size is used for the entire length of the conduit run. Extend conduit in concrete foundations 2 to 3 in. above the concrete. Seal the ends of each conduit with silicone caulking, or other approved sealant, after all cables and conductors are installed.

- 3.1.1.3. **Wiring.** Furnish stranded No. 12 AWG XHHW conductors. Install above-ground cables and conductors in rigid metal conduit, except for span wire suspended cables and conductors, drip loops, and electrical wiring inside signal poles unless otherwise shown on the plans. Make power entrances to ground-mounted controllers through underground conduit. Wire each signal installation to operate as shown on the plans.
- Attach ends of wires to properly sized self-insulated solderless terminals. Attach terminals to the wires with a ratchet-type compression crimping tool properly sized to the wire. Place pre-numbered identification tags of plastic or tape around each wire adjacent to wire ends in the controller and signal pole terminal blocks.
- Splices will not be permitted except as shown on the plans, unless each individual splice is approved in writing. Make all allowed splices watertight.
- 3.1.1.4. **Grounding and Bonding.** Ground and bond conductors in accordance with the NEC. Ensure the resistance from the grounded point of any equipment to the nearest ground rod is less than 1 ohm.
- Install a continuous bare or green insulated copper wire (equipment ground) throughout the electrical system that is the same size as the neutral conductor, but a minimum No. 8 AWG. Connect the equipment ground to all metal conduit, signal poles, controller housing, electrical service ground, ground rods, and all other metal enclosures and raceways.
- Provide copper wire bonding jumpers that are a minimum No. 8 AWG.
- 3.1.2. **Controller Assemblies.** Construct controller foundations in accordance with Item 656, "Foundations for Traffic Control Devices." Immediately before mounting the controller assembly on the foundation, apply a bead of silicone caulk to seal the cabinet base. Seal any space between conduit entering the controller and the foundation with silicone caulk.
- Deliver the keys for the controller cabinets to the Engineer when the Contract is complete.
- Place the instruction manual and wiring diagrams for all equipment in the controller cabinet, inside the controller cabinet.
- 3.1.3. **Timber Poles.** Furnish ANSI Class 2 timber poles other than for electrical services in accordance with details shown on the plans.
- 3.1.4. **Preservation of Sod, Shrubbery, and Trees.** Replace sod, shrubbery, and trees damaged during the Contract.
- 3.1.5. **Removal and Replacement of Curbs and Walks.** Obtain approval before cutting into or removing walks or curbs not shown on the plans to be removed or replaced. Restore any curbs or walks removed equivalent to original condition after work is completed, to the satisfaction of the Engineer.
- 3.1.6. **Intersection Illumination.** Install luminaires on signal poles as shown on the plans.
- 3.1.7. **Signal Timing Plan.** The traffic signal timing plan will be provided by the Department or local entity.
- 3.1.8. **Test Period.** Operate completed traffic signal installations continuously for at least 30 days in a satisfactory manner. If any Contractor-furnished equipment fails during the 30-day test period, repair or replace that equipment. This repair or replacement, except lamp replacement, will start a new 30-day test period.
- Replace materials that are damaged or have failed before acceptance. Replace failed or damaged existing signal system components when caused by the Contractor. The Department will relieve the Contractor of maintenance responsibilities upon passing a 30-day performance test of the signal system and acceptance of the Contract.

- 3.2. **Removal.** Remove existing electrical services, pedestal poles, strain poles, mast arm pole assemblies, luminaires, signal heads, vehicle detector equipment, controllers, cables, and other accessories. Remove materials so damage does not occur. Remove and store items designated for reuse or salvage at locations shown on the plans or as directed.

Remove abandoned concrete foundations, including steel, to a point 2 ft. below final grade. Backfill holes with material equal in composition and density to the surrounding area. Replace surfacing material with similar material to an equivalent condition.

Accept ownership and dispose of unsalvageable materials in accordance with federal, state, and local regulations.

4. MEASUREMENT

This Item will be measured as each traffic signal installed or removed. A traffic signal is a signalized intersection controlled by a single traffic signal controller.

5. PAYMENT

The work performed and materials furnished in accordance with this Item and measured as provided under "Measurement" will be paid for at the unit price bid for "Installation of Highway Traffic Signals" of the type (isolated, system, or flashing beacon) specified, or "Removing Traffic Signals."

- 5.1. **Installation.** This price is full compensation for furnishing, installing, and testing the completed installation, controller and associated equipment, controller foundations, luminaires, signs mounted on signal equipment, damping plates, timber poles, mounting hardware and steel wire strand; preservation and replacement of damaged sod, shrubbery and trees; removal and replacement of curbs and walks; and materials, equipment, labor, tools, and incidentals. The Department will pay for electrical energy consumed by the traffic signal.
- New drilled shaft foundations for traffic signal poles will be paid for under Item 416, "Drilled Shaft Foundations." New conduit will be paid for under Item 618, "Conduit." New electrical conductors will be paid for under Item 620, "Electrical Conductors." New ground boxes will be paid for under Item 624, "Ground Boxes." New electrical services will be paid for under Item 628, "Electrical Services." New vehicle and pedestrian signal heads will be paid for under Item 682, "Vehicle and Pedestrian Signal Heads." New traffic signal cables will be paid for under Item 684, "Traffic Signal Cables." New traffic signal pole assemblies will be paid for under Item 686, "Traffic Signal Pole Assemblies (Steel)." New traffic signal detectors will be paid for under Item 688, "Pedestrian Detectors and Vehicle Loop Detectors."
- 5.2. **Removal.** This price is full compensation for removing the various traffic signal components; removing the foundations; disposal of unsalvageable materials; hauling; and materials, equipment, labor, tools, and incidentals.

Item 681

Temporary Traffic Signals



1. DESCRIPTION

Furnish, install, operate, maintain, reconfigure, and remove temporary traffic signals.

2. MATERIALS

Furnish new or used materials in accordance with the details shown on the plans, the requirements of this Item, and the pertinent requirements of the following Items, except for measurement and payment:

- Item 416, "Drilled Shaft Foundations,"
- Item 610, "Roadway Illumination Assemblies,"
- Item 618, "Conduit,"
- Item 620, "Electrical Conductors,"
- Item 621, "Tray Cable,"
- Item 622, "Duct Cable,"
- Item 624, "Ground Boxes,"
- Item 625, "Zinc-Coated Steel Wire Strand,"
- Item 627, "Treated Timber Poles,"
- Item 628, "Electrical Services,"
- Item 636, "Signs,"
- Item 656, "Foundations for Traffic Control Devices,"
- Item 680, "Highway Traffic Signals,"
- Item 682, "Vehicle and Pedestrian Signal Heads,"
- Item 684, "Traffic Signal Cables,"
- Item 686, "Traffic Signal Pole Assemblies (Steel),"
- Item 687, "Pedestal Pole Assemblies," and
- Item 688, "Pedestrian Detectors and Vehicle Loop Detectors"

Obtain signal equipment at locations shown on the plans if the equipment is furnished by the Department. All materials determined to be in good working condition by the Engineer can be reused on temporary traffic signals. Do not use previously installed materials for permanent traffic signal installations.

3. CONSTRUCTION

Install traffic signal assemblies in accordance with Item 680, "Highway Traffic Signals," (except for measurement and payment) as shown on the plans. Install electrical services in accordance with Item 628, "Electrical Services," (except for measurement and payment) as shown on the plans.

- 3.1. **Operation and Maintenance.** Maintain and operate the temporary traffic signals for the duration of the Contract. The traffic signal timing plan will be provided by the Department or local entity. Set signal timing as shown on the plans or as directed.

Designate in writing a sufficiently skilled individual responsible for maintenance and operation of the temporary traffic signals who is available to respond within a reasonable time, 24 hr. each day, unless otherwise shown on the plans.

Provide backup power for each location at all times, when shown on the plans.

- 3.2. **Reconfiguration.** Reconfigure temporary traffic signals in accordance with the plans, and within the requirements of this Item, as directed. Reconfiguration is any change made to an installed intersection, including relocation of poles, controller, signal heads, or luminaires.
- 3.3. **Removal.** Remove all equipment installed for temporary traffic signals as shown on the plans or as directed in writing.

Completely remove poles or other supports used for temporary traffic signals. When approved, concrete foundations may remain 2 ft. or more below finished grade. Backfill the remaining hole with material equal in composition and density to the surrounding area. Replace any surfacing, such as asphalt pavement or concrete riprap, with like material to equivalent condition.

Retain all removed temporary signal components, except for those furnished by the Department, unless otherwise shown on the plans.

4. MEASUREMENT

This Item will be measured by each temporary signalized intersection. A signalized intersection is a group of signals operated by a single controller.

5. PAYMENT

The work performed and materials furnished in accordance with this Item and measured as provided under "Measurement" will be paid for at the unit price bid for "Temporary Traffic Signals." This price is full compensation for picking up and returning materials furnished by the Department; installation, operation, maintenance, reconfiguration, and removal of the temporary traffic signal consisting of traffic signal pole assemblies, vehicle and pedestrian signal heads, vehicle loop detectors, pedestrian detectors, traffic signals, flasher controllers, and associated equipment, signs, luminaires, ground boxes, conduit, traffic signal cables, conductors, wire strand, and electrical services; installation and removal of foundations; and materials, equipment, labor, tools, and incidentals.

Electrical energy consumed by the Contractor on an existing Department electrical service will be paid for by the Department.

Costs for utility-owned power line extensions, connection charges, meter charges, consumption charges, and other charges will be paid for by the Department. The Department will reimburse the Contractor the amount billed by the utility plus an additional 5% of the invoice cost will be paid for labor, equipment, administrative costs, superintendence, and profit.

Item 682

Vehicle and Pedestrian Signal Heads



1. DESCRIPTION

Furnish and install vehicle and pedestrian signal heads.

2. MATERIALS

Furnish only new materials.

2.1. Definitions.

- **Back Plate.** A thin strip of material extending outward from all sides of a signal head.
- **LED Optical Unit.** The LED lens and associated supporting parts in a signal section.
- **Louwer.** A device mounted to the visor restricting signal face visibility.
- **Signal Section.** One housing case, housing door, visor, and optical unit.
- **Signal Face.** One section or an assembly of 2 or more sections facing one direction.
- **Signal Head.** A unidirectional face or a multidirectional assembly of faces, including back plates and louvers when required, attached at a common location on a support.

2.2. General.

Provide vehicle signal heads in accordance with DMS-11121, "Twelve-Inch LED Traffic Signal Lamp Unit." Provide prequalified vehicle signal heads from the Department's MPL.

Provide pedestrian signal heads in accordance with DMS-11131, "Pedestrian LED Countdown Signal Modules." Provide prequalified pedestrian signal heads from the Department's MPL.

Supply either aluminum or polycarbonate signal head components of the same material and manufacturer for any one project.

Use galvanized steel, stainless steel, or dichromate sealed aluminum bolts, nuts, washers, lock washers, screws, and other assembly hardware. When dissimilar metals are used, ensure the metals are selected or insulated to prevent corrosion.

Use closed-cell silicone or closed-cell neoprene gaskets.

3. CONSTRUCTION

3.1. Assembly.

Assemble individual signal sections in multi-section faces in accordance with the manufacturer's recommendations to form a rigid signal face. Assemble and mount signal heads as shown on the plans. Install louvers and back plates in accordance with the manufacturer's recommendations. Close any openings in an assembled signal head with a plug of the same material and color as the head.

Remove only the existing lens, reflector, and incandescent lamp when installing a retrofit replacement LED traffic signal or pedestrian signal lamp unit into an existing signal housing; fit the new unit securely in the housing door; and connect the new housing unit to the existing electrical wiring or terminal block by means of simple connectors.

3.2. Wiring.

Wire each optical unit to the terminal block located in that signal section by means of solderless wire connectors or binding screws and spade lugs. Wire all sections of a multi-section signal face to the section terminal blocks in which the traffic signal cable is terminated. Maintain the color coding on leads from the

individual optical units throughout the signal head, except for the traffic signal cable. Use solderless wire connectors or binding screws and spade lugs for connections to terminal blocks. Use binding screws and spade lugs for field wiring.

4. MEASUREMENT

This Item will be measured by each vehicle signal section, pedestrian signal section, back plate, or louver.

5. PAYMENT

The work performed and materials furnished in accordance with this Item and measured as provided under "Measurement" will be paid for at the unit price bid for "Pedestrian Signal Section," "Vehicle Signal Section," "Back Plate," or "Louver," of the types and sizes specified. This price is full compensation for furnishing, assembling, and installing the signal sections, back plates and louvers, and lenses and optics; mounting attachments; and materials, equipment, labor, tools, and incidentals.

Item 684

Traffic Signal Cables



1. DESCRIPTION

Furnish and install traffic signal cables.

2. MATERIALS

Provide polyethylene-jacketed multi-conductor cables in accordance with details shown on the plans. Individual conductors must be copper with polyethylene insulation rated for 600 volts. Furnish new materials. Provide traffic signal cables in accordance with DMS-11110, "Traffic Signal Cable."

- 2.1. **Type A Cables.** Use Type A cables meeting the requirements of IMSA 20-1 for underground conduit installation or aerial cable supported by a messenger.
- 2.2. **Type B Cables.** Use Type B cables meeting the requirements of IMSA 20-3 as the integral messenger cable for aerial installations.
- 2.3. **Type C Cables.** Use Type C cables meeting the requirements of IMSA 50-2 for loop detector lead-in installations consisting of 2 conductor shielded cable.
- 2.4. **Types A and B Cable Materials.** Provide the following materials for Type A and B cables:
- Use the size and number of conductors shown on the plans. Unless otherwise shown on the plans, use conductors consisting of 7 copper strands.
 - Ensure color coding of conductors and sequence for cables are in compliance with Table 1. Base color is the insulation color. Tracer color is the colored stripe that is part of or firmly adhered to the insulation surface for the full length of the conductor.
 - Ensure 2-conductor cable is of the round twisted type with fillers used where necessary to form a round cable.
 - For cables with more than 2 conductors, ensure individual conductors are laid up symmetrically in layers with fillers used when necessary, to produce a uniform assembly of conductors with a firm, compact cylindrical core.
 - Ensure fillers are a non-metallic, moisture-resistant, non-wicking material.
 - Supply conductor assemblies covered with a wrapping of a moisture-resistant tape applied to overlap at least 10% of the tape width.
 - Ensure the taped conductor assembly is covered with a tightly fitting black polyethylene jacket that is smooth and free from holes, splits, blisters, and any other imperfections.
 - Supply cables that clearly show the name of the manufacturer and the IMSA specification number applied at approximate 2-ft. intervals to the outer surface of the jacket by indent printing.

Table 1
Conductor Color and Sequence for Cables

Conductor No.	Base Color	Tracer Color
1	Black	
2	White	
3	Red	
4	Green	
5	Orange	
6	Blue	
7	White	Black
8	Red	Black
9	Green	Black
10	Orange	Black
11	Blue	Black
12	Black	White
13	Red	White
14	Green	White
15	Blue	White
16	Black	Red
17	White	Red
18	Orange	Red
19	Blue	Red
20	Red	Green
21	Orange	Green

- 2.5. **Additional Requirements for Type B Cable Materials.** Additional material requirements particular to Type B cable are as follows:
- Ensure cables consisting of 5 or more conductors have a 0.25-in. nominal diameter messenger. For the messenger, use Class A galvanized Extra High Strength Steel Strand with 3 or 7 wires.
 - A solid strand messenger with 0.134-in. diameter may be used for cables with less than 5 conductors.
 - To provide corrosion protection, ensure the messenger strand is coated and the interstices are flooded with a rubber asphalt compound or equivalent.
 - Ensure the integral messenger and conductors are enclosed in the jacket forming a cross-section similar to a figure 8.
- 2.6. **Type C Cable Materials.** Use the following materials for Type C cables:
- Unless otherwise shown on the plans, use No. 14 AWG insulated conductors with concentric stranding with black insulation on 1 of the 2 conductors and clear insulation on the other conductor. Ensure conductors have a minimum of 2 twists per foot within the cable.
 - Use cables that have 100% shield coverage using aluminum bonded to a Mylar film. Ensure the drain wire is stranded tinned copper, 2 AWG sizes less than the conductor, and in continuous contact with the aluminum side of the shield material.
 - Ensure the jacket is black polyethylene.
 - Use cables that legibly show the name of the manufacturer and the IMSA specification number applied at approximate 2-ft. intervals on a tape under the outer jacket.
- 2.7. **Sampling.** The Engineer may take samples from each roll of each size of cable for establishing conformity to IMSA. The samples will be at least 3 ft. long. Replace any cable failing to meet IMSA requirements.

3. CONSTRUCTION

For each cable run in underground conduit, coil an extra 5 ft. of cable in each ground box.

Splices are not permitted in Type A and B cables unless shown on the plans, or approved in writing. Ensure splices are watertight.

Make splices between Type C cable and loop detector wires only in the ground box near the loop the cable is servicing. Use non-corrosive solder for splices. Ground the drain wire of Type C cable to earth ground only at the controller or detector cabinet. Ensure the resistance from the drain wire to the ground rod is less than 1 ohm.

Test the cables after installation and before any connection to the cables. Cables testing less than 50 megohms insulation resistance at 500 volts will be rejected.

4. MEASUREMENT

This Item will be measured by the foot of traffic signal cables.

This is a plans quantity measurement Item. The quantity to be paid is the quantity shown in the proposal, unless modified by Article 9.2., "Plans Quantity Measurement." Additional measurements or calculations will be made if adjustments of quantities are required.

5. PAYMENT

The work performed and materials furnished in accordance with this Item and measured as provided under "Measurement" will be paid for at the unit price bid for "Traffic Signal Cables" of the types and sizes specified. This price is full compensation for furnishing and installing materials, and for equipment, labor, tools, and incidentals, except as shown below.

Cables inside traffic signal pole assemblies will be paid for under this Item.

Cables used for inside signal heads and controllers or coils in ground boxes, pole bases, and on span wires will not be paid for directly but will be subsidiary to pertinent Items.

Item 685

Roadside Flashing Beacon Assemblies



1. DESCRIPTION

- **Installation.** Furnish, fabricate, and erect roadside flashing beacon assemblies.
- **Relocation.** Remove and relocate existing roadside flashing beacon assemblies.
- **Removal.** Remove existing roadside flashing beacon assemblies.

2. MATERIALS

Furnish new materials in accordance with the following Items and details shown on the plans:

- Item 441, "Steel Structures"
- Item 442, "Metal for Structures"
- Item 445, "Galvanizing"
- Item 449, "Anchor Bolts"
- Item 656, "Foundations for Traffic Control Devices"

Provide prequalified flasher controller assemblies from the Department's MPL in accordance with DMS-11160, "Flasher Controller Assembly."

Provide prequalified pedestal pole bases from the Department's MPL in accordance with DMS-11140, "Pedestal Pole Base."

When shown on the plans, provide prequalified solar powered flasher controller assemblies from the Department's MPL in accordance with DMS-11150, "Solar Power Flasher Controller Assembly."

3. CONSTRUCTION

Install foundations for installation and relocation in accordance with Item 656, "Foundations for Traffic Control Devices."

- 3.1. **Fabrication.** Provide poles and bases in accordance with Item 687, "Pedestal Pole Assemblies." Provide mild steel anchor bolts in accordance with Item 449, "Anchor Bolts." Use galvanized bolts, nuts, and washers.
- 3.2. **Galvanizing.** Galvanize all fabricated parts in accordance with Item 445, "Galvanizing." Repair galvanizing for any steel part or member damaged in assembly, transit, or erection, or any steel part or member welded after galvanizing, in accordance with Section 445.3.5., "Repairs."
- 3.3. **Installation.** Install roadside flashing beacon assemblies at the locations shown on the plans or as directed. Stake the assembly locations for verification by the Engineer unless otherwise shown on the plans.

Install pole, breakaway base, connectors, wiring, signal beacons, sign, and foundation as shown on the plans, or as directed. Install the flasher controller assembly on the electrical service pole. Install watertight breakaway electrical fuse holders in all line and neutral conductors at the breakaway base.

Use established industry and utility safety practices to erect assemblies near overhead or underground utilities. Consult with the appropriate utility company before beginning such work.

Install solar panels, batteries, and battery box (when required) as shown on the plans or as directed.

- 3.4. **Relocation.** Disconnect and isolate the electrical power supply before removal of the assembly. Remove existing assembly as directed. Salvage existing components such as sign, beacons, pole, and base unless otherwise directed. Repair or replace lost or damaged components as directed.

Relocate existing assembly to the location shown on the plans or as directed. Install existing assembly at new foundations in accordance with Section 685.3.3., "Installation." Remove existing foundations in accordance with Section 685.3.5., "Removal." Accept ownership of unsalvageable materials and dispose of in accordance with federal, state, and local regulations.

- 3.5. **Removal.** Disconnect and isolate existing electrical power supplies before removal of the assembly. Remove existing sign panel, beacons, pole, and base from existing assembly. Store items to be reused or salvaged without damaging. Store sign panels above the ground in a vertical position at locations shown on the plans or as directed. Accept ownership of unsalvageable materials and dispose of in accordance with federal, state, and local regulations.

Remove abandoned foundations, including steel, to 2 ft. below the finished grade unless otherwise shown on the plans. Backfill with material equal in composition and density to the surrounding area, and replace any surfacing, such as asphalt pavement or concrete riprap, with like material to equivalent condition.

4. MEASUREMENT

This Item will be measured by each installed, relocated, or removed roadside flashing beacon assembly.

5. PAYMENT

The work performed and materials furnished in accordance with this Item and measured as provided under "Measurement" will be paid for at the unit price bid for "Install Roadside Flashing Beacon Assemblies," "Install Roadside Flashing Beacon Assemblies (Solar Powered)," "Relocate Roadside Flashing Beacon Assemblies," "Relocate Roadside Flashing Beacon Assemblies (Solar Powered)," "Remove Roadside Flashing Beacon Assemblies," or "Remove Roadside Flashing Beacon Assemblies (Solar Powered)." The Department will pay for electrical energy consumed by the roadside flashing beacon.

New conduit will be paid for under Item 618, "Conduit," except for conduit in the foundation and within 6 in. of the foundation. New electrical conductors will be paid for under Item 620, "Electrical Conductors." New tray cable will be paid for under Item 621, "Tray Cable." New duct cable will be paid for under Item 622, "Duct Cable." New ground boxes will be paid for under Item 624, "Ground Boxes." New electrical services will be paid for under Item 628, "Electrical Services." New signs will be paid for under Item 636, "Signs." New signal heads will be paid for under Item 682, "Vehicle and Pedestrian Signal Heads." New traffic signal cable will be paid for under Item 684, "Traffic Signal Cables."

- 5.1. **Installation.** This price is full compensation for furnishing, fabricating, galvanizing, assembling, and erecting the roadside flashing beacon assemblies including poles and bases; solar power flashing controller assemblies including battery box (when required); foundations; conduit in the foundation and within 6 in. of the foundation; furnishing and placing anchor bolts, nuts, washers, and templates; controller; and materials, equipment, labor, tools, and incidentals.
- 5.2. **Relocation.** This price is full compensation for removing the roadside flashing beacon assemblies; removing battery box (when required); removing existing foundations; installing new foundations; installing new conduit in the foundation and within 6 in. of the foundation; furnishing, fabricating, and installing any new components as required and replacing the assembly on its new foundations with all manipulations and electrical work; controller; salvaging; disposal of unsalvageable materials; loading and hauling; and materials, equipment, labor, tools, and incidentals.

- 5.3. **Removal.** This price is full compensation for removing the various roadside flashing beacon assemblies components; removing the foundations; storing the components to be reused or salvaged; disposal of unsalvageable materials; backfilling and surface placement; loading and hauling; and materials, equipment, tools, labor, and incidentals.

Item 686

Traffic Signal Pole Assemblies (Steel)



1. DESCRIPTION

- **Installation.** Fabricate, furnish, and install steel traffic signal pole assemblies.
- **Relocation.** Remove and relocate existing steel traffic signal pole assemblies.

2. MATERIALS

Provide new materials that comply with the details shown on the plans, the requirements of this Item, and the pertinent requirements of the following Items:

- Item 416, "Drilled Shaft Foundations"
- Item 421, "Hydraulic Cement Concrete"
- Item 441, "Steel Structures"
- Item 442, "Metal for Structures"
- Item 445, "Galvanizing"
- Item 449, "Anchor Bolts"

Furnish alloy steel or medium-strength mild steel anchor bolts in accordance with Section 449.2.1., "Bolts and Nuts," unless otherwise shown on the plans.

3. CONSTRUCTION

- 3.1. **Standard Design.** Fabricate poles assemblies in accordance with this Item to the designs shown on the plans. Alternate designs are not acceptable. Deviations that affect the basic structural behavior of the pole are considered to be alternate designs. For deviations that do not affect the basic structural behavior of the pole, electronically submit shop drawings in accordance with Item 441, "Steel Structures," to the Bridge Division for approval.
- 3.2. **Fabrication.** Fabricate and weld in accordance with Item 441, "Steel Structures," AWS D1.1, *Structural Welding Code—Steel*; and the requirements of this Item. Fabrication tolerances are given in Table 1.

Table 1
Fabrication Tolerances

Part	Dimension	Tolerance (in.)
Pole and mast arm shaft	Length	±1
	Thickness	+0.12, -0.02
	Difference between flats or diameter	±3/16
	Straightness	1/8 in 10 ft.
	Attachment locations	±1
Base and mast arm mounting plates	Overall	±3/16
	Thickness	+1/4, -0
	Deviations from flat	3/16 in 24 in.
	Spacing between holes	±1/8
	Bolt hole size	±1/16
Anchor bolts	Length	±1/2
	Threaded Length	±1/2
	Galvanized Length	-1/4
Assembled shafts	Angular Orientation	1/16 in 12 in. ¹
	Centering	±3/16
	Twist	3° in 50 ft.

1. 1/8 in 12 in. between mounting plates and between mounting plates and base plates.

Fabrication plants that produce steel traffic signal pole assemblies must be approved in accordance with DMS-7380, "Steel Non-Bridge Member Fabrication Plant Qualification." The Department maintains an MPL of approved traffic signal pole assembly fabrication plants.

Provide properly fitting components. Provide round or octagonal shafts for poles and mast arms tapered as shown on the plans. Fabricate mast arms straight in the unloaded condition unless otherwise shown on the plans. The Department will accept bolted slip joints overlapping by at least 1.5 diameters in mast arms 40 ft. and longer.

Provide circumferential welds only at the ends of the shafts. Provide no more than 2 longitudinal seam welds in shaft sections. Grind or smooth the exterior of longitudinal seam welds to the same appearance as other shaft surfaces. Ensure 100% penetration within 6 in. of circumferential base welds and 60% minimum penetration at other locations along the longitudinal seam welds. Use a welding technique that minimizes acid entrapment during later galvanizing. Hot-dip galvanize all fabricated parts in accordance with Item 445, "Galvanizing."

Treat welds with Ultrasonic Impact Treatment when shown on the plans after galvanization and with the dead load (actual or simulated) applied. Repair damaged galvanizing in accordance with Section 445.3.5., "Repairs."

Connect the luminaire arm to the pole with simplex fittings. Ensure the fittings have no defects affecting strength or appearance.

Permanently mark, at a visible location when erected, pole base plates and mast arm mounting plates with the design wind speed.

Permanently mark, at a visible location when erected, pole base plates and fixed mast arm mounting plates with the fabrication plant's insignia or trademark. Place the mark on the pole base plate adjacent to the hand-hole access compartment.

Deliver each traffic signal pole assembly with fittings and hardware either installed or packaged with its associated components. Ship all components with a weatherproof tag identifying the manufacturer, Contract number, date, and destination of shipment.

- 3.3. **Installation.** Locate traffic signal pole assemblies as shown on the plans unless otherwise directed to secure a more desirable location or avoid conflict with utilities. Stake the traffic signal pole assembly locations for verification by the Engineer.

Use established industry and utility safety practices when working near overhead or underground utilities. Consult with the appropriate utility before beginning work.

Construct foundations for new traffic signal pole assemblies in accordance with Item 416, "Drilled Shaft Foundations," and the details shown on the plans. Orient anchor bolts as shown on the plans.

Erect structures after foundation concrete has attained its design strength as required on the plans and Item 421, "Hydraulic Cement Concrete." Coat anchor bolt threads and tighten anchor bolts in accordance with Item 449, "Anchor Bolts."

After the traffic signal pole assembly is plumb and all nuts are tight, tack weld each anchor bolt nut in 2 places to its washer. Tack weld each washer to the base plate in 2 places. Never weld components to the bolt. Tack weld in accordance with Item 441, "Steel Structures." After tack welding, repair galvanizing damage on bolts, nuts, and washers in accordance with Section 445.3.5., "Repairs."

Do not grout between the base plate and the foundation.

- 3.4. **Relocation.** Disconnect and isolate traffic signal cables before removing the pole. Remove existing traffic signal pole assemblies as directed. Ensure the poles or attached components suffer no undue stress or damage. Signs, signal heads, mounting brackets, luminaires, etc., may be left on the poles. Repair or replace damaged components as directed.

Remove abandoned concrete foundations, including steel, to a point 2 ft. below final grade unless otherwise shown on the plans. Cut off and remove steel protruding from the remaining concrete. Backfill the hole with materials equal in composition and density to the surrounding area. Replace surfacing material with similar material to an equivalent condition.

Move existing pole assemblies to locations shown on the plans, or as directed. Construct foundations for relocated traffic signal pole assemblies in accordance with Item 416, "Drilled Shaft Foundations," and the details shown on the plans. Install existing pole assemblies on new foundations in accordance with Section 686.3.3., "Installation."

Accept ownership of unsalvageable materials and dispose of in accordance with federal, state, and local regulations.

4. MEASUREMENT

This Item will be measured by each traffic signal pole assembly installed or relocated.

5. PAYMENT

The work performed and materials furnished in accordance with this Item and measured as provided under "Measurement" will be paid for at the unit price bid for "Install Traffic Signal Pole Assemblies (Steel)" of the types and sizes specified or "Relocate Traffic Signal Pole Assemblies (Steel)" of the types specified.

New drilled shaft foundations will be paid for under Item 416, "Drilled Shaft Foundations."

- 5.1. **Installation.** This price is full compensation for furnishing, fabricating, galvanizing, assembling, and erecting the pole upon a foundation; furnishing and erecting required mast arms and luminaire arms; furnishing and placing anchor bolts, nuts, washers, and templates; and materials, equipment, labor, tools, and incidentals.
- 5.2. **Relocation.** This price is full compensation for removing traffic signal pole assemblies; removing existing foundations; backfilling and surface placement; storing the components to be reused or salvaged; furnishing, fabricating, and installing required new components including anchor bolts, nuts, washers, and templates; placing and securing traffic signal pole assemblies on new foundations; furnishing and placing conduit, ground rods, and wiring; disposal of unsalvageable materials; loading and hauling; and materials, equipment, labor, tools, and incidentals.

Item 687

Pedestal Pole Assemblies



1. DESCRIPTION

- **Installation.** Furnish and install pedestal pole assemblies for vehicle and pedestrian signals.
- **Relocation.** Remove and relocate existing pedestal pole assemblies.
- **Removal.** Remove existing pedestal pole assemblies.

2. MATERIALS

Furnish new materials in accordance with the following Items and with details shown on the plans:

- Item 445, "Galvanizing"
- Item 449, "Anchor Bolts"
- Item 656, "Foundations for Traffic Control Devices"

- 2.1. **Pedestal Pole Base.** Provide prequalified pedestal pole bases from the Department's MPL in accordance with DMS-11140, "Pedestal Pole Base."
- 2.2. **Pedestal Pole.** Provide 4-in. diameter schedule 40 steel pipe or tubing, aluminum pipe (alloy 6061 T6), or rigid metal conduit. Do not use aluminum conduit. Galvanize pedestal pole assemblies in accordance with Item 445, "Galvanizing," unless otherwise shown on the plans.
- 2.3. **Pedestrian Push Button Pole Assembly.** Provide diameter as shown on the plans, schedule 40 steel pipe or tubing, aluminum pipe (alloy 6061-T6), or rigid metal conduit. Do not use aluminum conduit. Galvanize pedestrian push button post in accordance with Item 445, "Galvanizing," unless otherwise shown on the plans.

3. CONSTRUCTION

Install foundations in accordance with Item 656, "Foundations for Traffic Control Devices."

- 3.1. **Pedestal Pole Base.** Ground the base with connectors to the 1/2-13 NC female threaded hole. Fabricate the base for 4 L bend anchor bolts arranged in a square pattern with a 12-3/4 in. bolt circle. Provide mild steel anchor bolts in accordance with Item 449, "Anchor Bolts," for each base. Provide three 1/16-in. thick and three 1/8-in. thick U-shaped galvanizing steel shims for each base. Size shims to fit around the anchor bolts.
- 3.2. **Installation.** Install pedestal pole assemblies and pedestrian push button post assemblies as shown on the plans, or as directed. Pedestal pole assemblies include foundation, pole shaft, base, anchor bolts, anchor bolt nuts, anchor bolt template, shims, and miscellaneous components. Watertight breakaway electrical disconnects are required for pedestal pole assemblies used in conjunction with vehicle and pedestrian heads and components. Pedestrian push button post assemblies include foundation, pole, and post cap.
- Use established industry and utility safety practices to erect assemblies near overhead or underground utilities. Consult with the appropriate utility company before beginning such work.
- Repair damaged galvanizing in accordance with Section 445.3.5., "Repairs."
- 3.3. **Relocation.** Disconnect and isolate the electrical power supply before removal of the assembly. Remove existing assembly as directed. Salvage existing components such as signs, heads, buttons, pole, and base unless otherwise directed. Repair or replace lost or damaged components as directed.

Install foundations in accordance with Item 656, "Foundations for Traffic Control Devices."

Relocate existing assembly to the location shown on the plans or as directed. Install existing assembly at new foundations in accordance with Section 687.3.2., "Installation." Remove existing foundations in accordance with Section 687.3.4., "Removal." Accept ownership of unsalvageable materials, as determined by the Engineer, and dispose of in accordance with federal, state, and local regulations.

Repair galvanizing for any damaged steel part or any steel part welded after galvanizing in accordance with Item 445, "Galvanizing."

- 3.4. **Removal.** Disconnect and isolate electrical power supplies before removal of the assembly. Remove existing sign panel, beacons, pole, and base from existing assembly. Store items to be reused or salvaged without damaging them. Store sign panels above the ground in a vertical position at locations shown on the plans or as directed. Accept ownership of unsalvageable materials and dispose of in accordance with federal, state, and local regulations.

Disconnect and remove conductors from abandoned circuits. Remove abandoned conduit and ducts to a point 6 in. below final grade. Destroy existing transformer bases to prevent reuse. Remove abandoned foundations to 2 ft. below the finished grade unless otherwise shown on the plans. Cut off and remove steel protruding from the remaining concrete. Backfill the remaining hole with material equal in composition and density to the surrounding area. Replace any surfacing with like material to equivalent condition.

- 3.5. **Painted Finish.** When required, paint pedestal pole and pedestrian push button post assemblies in accordance with details shown on the plans.

4. MEASUREMENT

This Item will be measured by each pedestal pole assembly or each pedestrian push button post assembly installed, relocated, or removed.

5. PAYMENT

The work performed and materials furnished in accordance with this Item and measured as provided under "Measurement" will be paid for at the unit price bid for "Install Pedestal Pole Assembly," "Install Pedestrian Push Button Post Assembly," "Relocate Pedestal Pole Assembly," "Relocate Pedestrian Push Button Post Assembly," "Remove Pedestal Pole Assembly" or "Remove Pedestrian Push Button Post Assembly."

New signal heads will be paid for under Item 682, "Vehicle and Pedestrian Signal Heads."

- 5.1 **Installation.** This price is full compensation for furnishing and installing the shaft; base, shims, anchor bolts, and foundation; and materials, equipment, labor, tools, and incidentals.
- 5.2 **Relocation.** This price is full compensation for removing the pedestal pole or pedestrian push button assemblies; removing existing foundations; installing new foundations; furnishing, fabricating, and installing any new components as required and replacing the assembly on its new foundations with all manipulations and electrical work; controller; salvaging; disposal of unsalvageable material; loading and hauling; and equipment, material, labor, tools, and incidentals.
- 5.3 **Removal.** This price is full compensation for removing the various pedestal pole assemblies components; removing the foundations; storing the components to be reused or salvaged; disposal of unsalvageable material; backfilling and surface placement; loading and hauling; and equipment, materials, tools, labor, and incidentals.

Item 688

Pedestrian Detectors and Vehicle Loop Detectors



1. DESCRIPTION

Furnish and install traffic signal detectors.

2. MATERIALS

Provide new materials that comply with the details shown on the plans, the requirements of this Item, and the pertinent requirements of the following Items:

- Item 618, "Conduit"
- Item 624, "Ground Boxes"
- Item 682, "Vehicle and Pedestrian Signal Heads"
- Item 684, "Traffic Signal Cables"

2.1. **Pedestrian Detectors.** Supply housing or an adapter (saddle) that conforms to the pole shape, fitting flush to ensure a rigid installation. Supply adapters of the same material and construction as the housing. Supply push-button switches that have single-pole, single-throw contacts and screw-type terminals and have a design life of at least 1 million operations.

Ensure the internal components provide a push-button with normal open contacts, and include all electrical and mechanical parts required for operation. Ensure the push-button assembly is weather-tight and tamperproof, is designed to prevent an electrical shock under any weather condition, and has provisions for grounding in accordance with the NEC.

2.1.1. **Standard Pedestrian Detectors.** Provide a 2-piece cast aluminum housing unit consisting of a base housing and a removable cover. Provide threaded holes for 0.5-in conduit in the housing for any necessary conduit attachment.

Ensure the manufacturer's name or trademark is located on the housing.

2.1.2. **Accessible Pedestrian Signals (APS).** Provide accessible pedestrian detectors in accordance with DMS-11132, "Accessible Pedestrian Signals (APS)."

2.2. **Vehicle Loop Detectors.** Use stranded copper No. 14 AWG XHHW cross-linked-thermosetting-polyethylene-insulated conductor rated for 600 volts AC for vehicle detector loop wire unless otherwise shown on the plans. Ensure each length of wire shows the name or trademark of the manufacturer, insulation voltage rating, wire gauge, and insulation type at approximate 2-ft. intervals on the insulation surface.

When shown on the plans, use flexible vinyl or polyethylene tubing with 0.184 in. minimum inside diameter, 0.031 in. minimum wall thickness, 0.26 in. maximum outside diameter, and a smooth bore. Use tubing that does not adhere to the loop wire in any way and is capable of resisting deterioration from oils, solvents, and temperatures up to 212°F. Use tubing that is abrasion-resistant and remains flexible from -22°F to 212°F. Use orange or red tubing unless otherwise shown on the plans.

Use sealant for the vehicle detector loops in accordance with DMS-6340, "Vehicle Loop Wire Sealant."

3. CONSTRUCTION

3.1. Pedestrian Detectors.

- 3.1.1. **Push-Button Unit.** Meet the requirements of the TMUTCD when installing push-buttons. Wire the push-button according to manufacturer's installation instructions. Close unused housing openings with a weather-tight closure painted to match the housing. Verify that each button is communicating and fully functional.

Do not use terminal connections or splice wire leads except at approved locations. All allowed splices must be watertight.

Attach wires to terminal posts with solderless terminals unless otherwise advised by manufacturer's recommendations. Attach terminals to the wires with a ratchet-type compression crimping tool properly sized to the wire.

Mount a pedestrian push button sign near each push button as shown on the plans.

For installations where APS buttons are placed less than 10 ft. apart from one another, program the appropriate speech walk message (include the name of the appropriate street in the message) for these buttons. When 2 APS buttons are installed on the same pole ensure that the APS buttons are insulated to eliminate vibrations from traveling to the other button.

- 3.1.2. **Controller Unit.** If a controller unit is required by the plans, integrate the pedestrian controller unit into the traffic signal controller cabinet assembly.

- 3.2. **Vehicle Loop Detectors.** Provide the loop location, configuration, wire color, and number of turns shown on the plans. Loops may be adjusted by the Engineer to fit field conditions.

- 3.2.1. **Saw-Cuts.** Cut the pavement with a concrete saw to form neat lines. Do not exceed 1 in. depth on concrete bridge slab saw-cuts. Cut all other saw-cuts deep enough to provide a minimum of 1 in. depth of sealant over the wire. Make a separate saw-cut from each loop to the edge of the pavement unless otherwise shown on the plans. Ensure the cut is clean and dry when the wire and sealant are placed.

- 3.2.2. **Conduit.** Place conduit between the pavement and ground box as shown on the plans.

- 3.2.3. **Loop Wire Color.** Use the following color code unless otherwise shown on the plans. Use white for the first loop on the right followed by black, orange, green, brown, and blue. Use the same color for all loops in the same lane. Loops installed in multi-lanes will have the same color code in the order the loops are installed. When facing the same direction that traffic flows, the color code will read from right to left for all lanes carrying traffic in that direction. If traffic moves in 2 directions, the color code will be repeated for the other direction of traffic.

- 3.2.4. **Loop Wire Installation.** When shown on the plans, place the loop wire in a flexible vinyl or polyethylene tubing in accordance with Article 688.2., "Materials." The loop wire color requirements do not apply to wires in tubing.

Twist the wire from the loop to the ground box a minimum of 5 turns per foot. When only one pair of wires is in a saw-cut, it need not be twisted while in the saw-cut. Do not splice loop wire in the loop or in the run to the ground box.

Hold the loop wire in place every 2 ft. with strips of rubber, neoprene flexible tubing, or polyethylene foam sealant approximately 1 in. long. Leave these strips in place and fill the slot with loop sealant.

Splice the loop lead-in cable and loop detector wires only in the ground box near the loop it is serving. Use non-corrosive solder for splices and ensure the splice is watertight. Ground the drain wire of the loop lead-in

cable to earth ground only at the controller or detector cabinet. Ensure the resistance from the drain wire to the ground rod is less than 1 ohm.

4. MEASUREMENT

This Item will be measured by the foot of saw-cut containing loop wire and each pedestrian push-button and controller unit.

This is a plans quantity measurement Item. The quantity to be paid is the quantity shown in the proposal, unless modified by Article 9.2., "Plans Quantity Measurement." Additional measurements or calculations will be made if adjustments of quantities are required.

5. PAYMENT

The work performed and materials furnished in accordance with this Item and measured as provided under "Measurement" will be paid for at the unit price bid for "Vehicle Loop Detectors" of the type specified, "Pedestrian Detector Push-button Units" of the type specified or "Pedestrian Detector Controller Unit." This price is full compensation for furnishing, installing, and testing the detectors, detector controller units, including detector configuration devices or software (when applicable); saw-cutting, excavation, backfill, sealant, and sealant placement; pavement repair associated with saw-cutting; and materials, equipment, labor, tools, and incidentals, except as follows.

The conduit and loop wire from the edge of pavement to the ground box used for the vehicle loop detectors will not be measured or paid for directly but will be subsidiary to this Item.

New ground boxes will be paid for under Item 624, "Ground Boxes." New loop lead-in cable will be paid for under Item 684, "Traffic Signal Cables."

Item 690

Maintenance of Traffic Signals



1. DESCRIPTION

Furnish, install, modify, repair, replace, or remove components of a traffic signal:

2. MATERIALS

The Department will only furnish traffic signal poles, mast arms, and controllers that become part of the final installation, unless otherwise noted on the plans. Submit a materials list to the Engineer for all poles, mast arms, and controllers needed. Pick up materials at the locations and times shown on the plans. Designate in writing the persons authorized to pick up the materials.

Assume responsibility for all materials furnished by the Department. Use materials furnished by the Department for this Contract only. Return unused or removed materials deemed salvageable by the Engineer to the Department upon completion of the work and before final payment at location shown on the plans or as directed. Dispose of materials deemed unsalvageable by the Engineer, in accordance with federal, state, and local regulations. When materials are required to be furnished by the Contractor, meet the Materials Article requirements of the pertinent Item.

3. EQUIPMENT

Use equipment that includes, but is not limited to:

- an aerial device capable of reaching overhead work,
- trenching machine,
- boring machine,
- concrete saw, and
- digger-boom truck.

Use only equipment, tools, and machinery in good repair and operating condition. Repair or replace any equipment that, in the opinion of the Engineer, may affect the quality of work or safety.

4. WORK METHODS

Conform to the NEC, local utility requirements, requirements of this Item, and pertinent requirements of the following Items:

- Item 416, "Drilled Shaft Foundations,"
- Item 421, "Hydraulic Cement Concrete,"
- Item 476, "Jacking, Boring, or Tunneling Pipe or Box,"
- Item 610, "Roadway Illumination Assemblies,"
- Item 618, "Conduit,"
- Item 620, "Electrical Conductors,"
- Item 622, "Duct Cable,"
- Item 624, "Ground Boxes,"
- Item 625, "Zinc-Coated Steel Wire Strand,"
- Item 627, "Treated Timber Poles,"
- Item 628, "Electrical Services,"
- Item 636, "Signs,"

- Item 656, "Foundations for Traffic Control Devices,"
- Item 680, "Highway Traffic Signals,"
- Item 682, "Vehicle and Pedestrian Signal Heads,"
- Item 684, "Traffic Signal Cables,"
- Item 685, "Roadside Flashing Beacon Assemblies,"
- Item 686, "Traffic Signal Pole Assemblies (Steel),"
- Item 687, "Pedestrian Pole Assemblies," and
- Item 688, "Pedestrian Detectors and Vehicle Loop Detectors."

Perform the following work as directed:

- 4.1. **Conduit.** Install, replace, remove, or modify conduits in accordance with Item 618, "Conduit"; as shown on the plans; or as directed. Use 90° "sweep" type elbow on conduits entering a ground box.
- 4.2. **Foundations.** Install, replace, or remove foundations for traffic signal pole, pedestal pole, and ground mount controller cabinets in accordance with Item 416, "Drilled Shaft Foundations"; and in accordance with Item 656, "Foundations for Traffic Control Devices"; as shown on the plans; or as directed.
- 4.3. **Concrete.** Install concrete in accordance with Item 421, "Hydraulic Cement Concrete."
- 4.4. **Ground Boxes.** Install, repair, replace, remove, or modify ground boxes in accordance with Item 624, "Ground Boxes"; as shown on the plans; or as directed.
- 4.5. **Vehicle and Pedestrian Detectors.** Install, repair, replace, remove, or modify pedestrian push buttons and vehicle loop detectors in accordance with Item 688, "Pedestrian Detectors and Vehicle Loop Detectors"; as shown on the plans; or as directed.
- 4.6. **Electrical Service.** Install, repair, replace, remove, or modify an electrical service assembly in accordance with Item 628, "Electrical Services"; as shown on the plans; or as directed. Mount any or all of the following on an electrical service support assembly: conduit, weather head, load center, meter base, lightning protection, wiring, and associated hardware.
- 4.7. **Signal Pole.** Install, repair, replace, remove, or modify signal poles in accordance with pertinent Items, as shown on the plans, or as directed. Comply with Item 627, "Treated Timber Poles," for timber signal poles with guy wires and anchors and Item 686, "Traffic Signal Pole Assemblies (Steel)," for steel poles with concrete foundations. Remove timber poles and anchors completely, to 24 in. below ground level, or as directed. Remove concrete foundations to 24 in. below ground level, or as directed.

Install, repair, replace, remove, or modify pedestrian signal pole assemblies in accordance with Item 687, "Pedestrian Pole Assemblies"; as shown on the plans; or as directed. Install, repair, replace, remove, or modify roadside flashing beacons in accordance with Item 685, "Roadside Flashing Beacon Assemblies"; as shown on the plans; or as directed.
- 4.8. **Down Guy.** Install, replace, remove, or modify down guy with guard or down guy with anchor and guard.
- 4.9. **Steel Wire Strand.** Install, replace, or remove steel wire strand in accordance with Item 625, "Zinc-Coated Steel Wire Strand"; as shown on the plans; or as directed. Attach span wire on timber poles using a 5/8-in. straight thimble-eye bolt. Attach span wire on metal poles using at least 2 turns of wire around the pole. Place and properly tighten the 3-bolt clamp as near as possible to the pole.
- 4.10. **Luminaire Head and Mast Arm.** Install, replace, remove, or modify luminaire heads, arms, bulbs, photocells, and hardware on timber or steel signal poles. Install material using manufacturer's specifications. Fuse luminaires individually in the signal pole hand-hole. Install a separate cable from the breaker load panel to each luminaire.

- 4.11. **Signal Head Assembly.** Install, repair, replace, remove, or modify pedestrian signal heads or vehicle signal head assemblies in accordance with Item 682, "Vehicle and Pedestrian Signal Heads"; as shown on the plans; or as directed. Mount signal heads by a span wire hanger clamp, bracket arm assembly, or mast arm bracket assembly. Signal head assemblies consist of 1 to 12 signal sections. Install signal heads as shown on the plans, or as directed.
- Assemble the signal heads with backplates, louvers, and brackets as needed. Mount all signal heads at the same elevation. Install signal head perpendicular to the travel lane it controls. Plumb all signal heads vertically and horizontally.
- 4.12. **Traffic Signal Controller Cabinet, Ground Mount.** Install, repair, replace, remove, or modify ground-mounted cabinet. Plumb and tighten the cabinet. Apply silicone sealant around the base of the cabinet. Coil all cabling that enters the cabinet neatly on the cabinet floor. Mark and terminate each cable as shown on the plans, or as directed.
- 4.13. **Traffic Signal Controller Cabinet, Pole Mount.** Install, repair, replace, remove, or modify pole-mounted cabinet. Plumb and tighten the cabinet. Coil all cabling that enters the cabinet neatly on the cabinet floor. Mark and terminate each cable as shown on the plans, or as directed.
- 4.14. **Flashing Beacon Controller Cabinet.** Install, repair, replace, remove, or modify flasher cabinet. Plumb and tighten the cabinet. Coil all cabling that enters the cabinet neatly on the cabinet floor. Mark and terminate each cable as shown on the plans, or as directed.
- 4.15. **Cables.** Install, repair, replace, remove, or modify signal, loop lead-in, electrical, communication, or illumination cables in conduits or along messenger cables in accordance with Item 620, "Electrical Conductors"; in accordance with Item 684, "Traffic Signal Cables"; as shown on the plans; or as directed.
- Attach aerial cable at 1-ft. intervals using approved cable ties along a messenger span cable. Install a drip loop with at least 2 turns at each pole, signal head, and weather head.
- Label each cable brought into the controller cabinet. Coil 5 ft. of cable neatly on the traffic signal controller cabinet floor for each cable.
- Install solderless pressure connectors that meet the requirements of the NEC for all wires attached to terminal posts. Use a ratchet-type full-circle crimper for insulated terminals to provide a solderless pressure connector.
- 4.16. **Sealing.** Install, repair, replace, remove, or modify sealant in detector saw slots, at the open end of all conduits terminated at the roadway edge, and in ground boxes. Apply sealant as shown on the plans or as directed.
- 4.17. **Salvage Operations.** Remove traffic signal when no replacement is required. Return unused or removed material deemed salvageable by the Engineer to the Department. Dispose of all other material.
- 4.18. **Signal-Related Signs.** Install, repair, replace, remove, or modify small post-mounted or overhead signs.
- 4.19. **Curbs, Ramps, and Sidewalks.** Install, repair, replace, remove, or modify curbs, ramps, and sidewalks. Secure permission to install traffic signal items before cutting into or removing curbs, ramps, and sidewalks. Replace all curbs, ramps, and sidewalks as shown on the plans. Install pedestrian access ramps as shown on the plans.
- 4.20. **Protection of Utilities.** Locate and protect all public lines and utility customer service lines in the work area. Notify the utility company and locate and mark, uncover, or otherwise protect all such lines in the construction area. Obtain information on the location and grade of water, sewer, gas, telephone, electric lines, and other utilities in the work area from the utility company. This information does not relieve the Contractor of responsibility for protecting utilities.

Reimburse the utility line owner for expenses or costs (including fines that may be levied against the utility company) that may result from unauthorized or accidental damage to any utility lines in work area.

- 4.21. **Preservation of Sod, Shrubbery, and Trees.** Preserve all sod, shrubbery, and trees at the site during the Contract. Obtain permission to remove any sod, shrubbery, or tree branches. Preserve and restore sod and shrubbery into their original position. Replace damaged sod or shrubbery at the Contractor's expense.
- 4.22. **PVC Weatherproof Enclosures.** Install, remove, or replace 12 × 12 × 6-in. PVC weatherproof enclosure at locations shown on the plans or as directed. Only use enclosure for reconnecting or terminating traffic signal cables at the top of a timber or steel strain pole which has been replaced or reinstalled due to accidental knock down.
- 4.23. **LED Lamp Unit.** Install, replace, or remove LED optical unit in accordance with Item 682, "Vehicle and Pedestrian Signal Heads"; as shown on the plans; or as directed.
- 4.24. **Spread Spectrum Radio Antennas.** Replace, repair, or install spread spectrum radio antenna in accordance with Special Specification, "Spread Spectrum Radios for Traffic Signals"; as shown on the plan; or as directed.
- 4.25. **Video Imaging Vehicle Detection System (VIVDS).** Install, repair, replace, remove, or modify VIVDS in accordance with Special Specification, "Video Imaging Vehicle Detection System," as shown on the plans, or as directed.

5. MEASUREMENT

Measurement will be as follows:

- 5.1. **Removal of Conduit.** By the foot of conduit.
- 5.2. **Installation of Conduit by Trenching.** By the foot of the trench containing conduit, regardless of the size of conduit.
- 5.3. **Installation of Conduit by Jacking or Boring.** By the foot of road bore made. Pits for jacking or boring are subsidiary to this Item.
- 5.4. **Installation of Vehicle Detectors.** By the foot of saw-cut containing detector wire.
- 5.5. **Removal, Replacement, or Installation of Ground Boxes.** By each box removed, replaced, or installed, regardless of the type of box. A concrete apron around the box will be considered subsidiary to this Item.
- 5.6. **Removal, Replacement, or Installation of Cables.** By the foot of traffic signal cables removed, replaced, or installed, except measurement will not be made for cable inside signal heads and controllers or cable coiled in ground boxes, in pole bases, and on span wires.
- 5.7. **Installation of Duct Cables.** By the foot of trench containing duct cable.
- 5.8. **Removal, Replacement, or Installation of Cables by Messenger Cable.** By the foot removed, replaced, or installed.
- 5.9. **Removal, Replacement, or Installation of Span Cable Assembly.** By the foot of span removed, replaced, or installed. A span is defined as the distance from one pole to the next pole.
- 5.10. **Replacement or Installation of Electrical Service.** By each electrical service replaced or installed. The removal of the existing assembly will be considered subsidiary to this Item.

- 5.11. **Removal, Replacement, or Installation of Timber Poles.** By each timber pole removed, replaced, or installed. Attachment of required hardware is subsidiary to this Item.
- 5.12. **Removal, Replacement, or Installation of Signal Head Assemblies.** By each head removed, replaced, or installed. Assembly and wiring are subsidiary to this Item.
- 5.13. **Removal, Replacement, or Installation of Signal Related Signs.** By each sign assembly removed, replaced, or installed.
- 5.14. **Removal, Replacement, or Installation of Pedestrian Push Buttons.** By each push button removed, replaced, or installed.
- 5.15. **Removal, Replacement, or Installation of Traffic Signal Pole Foundations.** By the foot, of the type of foundation removed, replaced, or installed.
- 5.16. **Installation of Foundations for Ground Mount or Pole Mount Cabinets.** By each foundation installed.
- 5.17. **Removal, Replacement, or Installation of Controller Cabinet, Ground Mount.** By each cabinet removed, replaced, or installed.
- 5.18. **Removal, Replacement, or Installation of Controller Cabinet, Pole Mount.** By each cabinet removed, replaced, or installed.
- 5.19. **Removal, Replacement, or Installation of Flasher Cabinet.** By each cabinet removed, replaced, or installed.
- 5.20. **Installation of Foundations for Roadside Flashing Beacon Assemblies.** By each foundation installed.
- 5.21. **Removal, Replacement, or Installation of Roadside Flashing Beacon Assemblies.** By each assembly removed, replaced, or installed.
- 5.22. **Removal, Replacement, or Installation of Signal Pole Assemblies.** By each assembly, according to the type of pole assembly removed, replaced, or installed. Wiring in the pole and hardware is subsidiary to this Item.
- 5.23. **Removal, Replacement, or Installation of Curbs.** By the foot removed, replaced, or installed.
- 5.24. **Removal, Replacement, or Installation of Pedestrian Ramps.** By each ramp removed, replaced, or installed.
- 5.25. **Removal, Replacement, or Installation of Sidewalks.** By the square foot removed, replaced, or installed.
- 5.26. **Removal of Concrete Foundations.** By each foundation removed.
- 5.27. **Removal, Replacement, or Installation of Luminaire Heads.** By each luminaire head removed, replaced, or installed.
- 5.28. **Removal, Replacement, or Installation of Luminaire Mast Arms.** By each mast arm removed, replaced, or installed.
- 5.29. **Removal, Replacement, or Installation of Down Guy with Guard.** By each down guy with guard removed, replaced, or installed.
- 5.30. **Removal, Replacement, or Installation of Down Guy with Guard and Anchor.** By each down guy with guard and anchor removed, replaced, or installed.

- 5.31. **Remove and Salvage Traffic Signals.** By each signalized intersection salvaged. A signalized intersection is a group of traffic signals operated by a single controller.
- 5.32. **Removal, Replacement, or Installation of 12 × 12 × 6-in. PVC Weatherproof Enclosure.** By each PVC weatherproof enclosure removed, replaced, or installed.
- 5.33. **Removal, Replacement, or Installation of LED Lamp Unit.** By each LED lamp unit removed, replaced, or installed.
- 5.34. **Removal, Replacement, or Installation of Spread Spectrum Radio Antennas.** By each radio antenna removed, replaced, or installed.
- 5.35. **Removal, Replacement, or Installation of Video Imaging Vehicle Detection System (VIVDS).** By each camera assembly removed, replaced, or installed.

6. PAYMENT

The work performed and materials furnished in accordance with this Item and measured as provided under "Measurement" will be paid for at the unit prices for the various designations. This price is full compensation for furnishing all materials, equipment, labor, fines, tools, and incidentals. The Department will pay for electrical energy consumed by the traffic signal.

Wiring in the pole; splices; backfill (soil or concrete); sealing of conduit ends and loop detector saw slots; installation of loop wire and PVC for encased loops; protection of utilities; and preservation of sod, shrubbery, and trees will not be measured or paid for directly but will be subsidiary to pertinent Items.

700 Items

Maintenance

This page intentionally left blank

Item 700

Pothole Repair



1. DESCRIPTION

Repair potholes, spalled areas, depressions, and raveled or damaged pavement edges in roadway surfaces.

2. MATERIALS

Furnish materials, unless otherwise shown on the plans. Use materials that meet the requirements of the following Items, as shown on the plans.

- Item 300, "Asphalt, Oils, and Emulsions,"
- Item 330, "Limestone Rock Asphalt Pavement,"
- Item 334, "Hot-Mix Cold-Laid Asphalt Concrete Pavement,"
- Item 340, "Dense-Graded Hot-Mix Asphalt (Small Quantity),"
- DMS-9202, "Asphaltic Concrete Patching Material (Stockpile Storage or Bagged),"
- DMS-9203, "Rapid-Curing Asphaltic Concrete Patching Material (Containerized)," and
- DMS-9204, "Fiber Additives for Bituminous Mixtures."

3. WORK METHODS

Work requests are made on a callout basis. Begin physical repair within 24 hr. of notification, 3 hr. if emergency mobilization is required, unless otherwise shown on the plans.

- 3.1. **Standard Repair.** Remove loose and foreign materials from the repair area. Remove water, dry, and apply tack coat to surfaces of the repair area unless otherwise directed.

Place repair material in horizontal lifts as directed. Finish to grade and compact to conform to roadway surface. Compact with hand tamp, mechanical tampers, or rollers as directed or approved. Compact to achieve full consolidation.

Repair pavement edges to the line and grade of original pavement. Clean roadway surface after repair operations. Dispose of materials removed as directed or approved.

- 3.2. **Saw-Cut Repair.** Square the sides of the repair area by saw-cutting or other approved methods. Remove loose and foreign material. Clean and dry the repair area. Apply tack coat to surfaces of the repair area unless otherwise directed.

Place repair material in horizontal lifts no more than 3 in. deep. Finish to grade and compact to conform to roadway surface. Compact with hand tamp, mechanical tampers, or rollers as directed or approved. Compact to achieve full consolidation.

Repair pavement edges to the line and grade of original pavement. Clean roadway surface after repair operations. Dispose of materials removed as directed or approved.

4. MEASUREMENT

Emergency mobilization will be measured by each emergency work request. Pothole repair will be measured by the square yard of surface area or by the cubic yard, ton, or pound of material used. For Contracts with

callout work without emergency mobilization, the minimum quantity per callout respectively is 5 sq. yd., 1/2 cu. yd., 1/2 ton, or 150 lb., unless otherwise shown on the plans.

- 4.1. **Area.** The surface area of repairs will be measured.
- 4.2. **Volume.** Trucks will be measured and the loose volume in cubic yards will be calculated for legally transported loads. Level the load for measurement before beginning work. Level off the material remaining on the last load for measurement. Material not used at the end of the day will be deducted from the volume.
- 4.3. **Weight (Ton).** Trucks will be weighed on certified scales. Provide weight tickets. Material not used at the end of the day will be deducted from the weight. Measurement will be in accordance with Item 520, "Weighing and Measuring Equipment."
- 4.4. **Weight (Pound).** Materials furnished in a container will be measured by the pound as shown on the container.

5. PAYMENT

The work performed and materials furnished in accordance with this Item and measured as provided under "Measurement" will be paid for at the unit prices bid for "Pothole Repair (Standard)" or "Pothole Repair (Saw-Cut)" and "Emergency Mobilization," if required. The price bid for pothole repair is full compensation for furnishing materials, unless otherwise shown on the plans; application of the tack coat; removal and disposal of debris and excess material; leveling off or weighing the load for measurement; and equipment, labor, tools, and incidentals.

The price bid for emergency mobilization is full compensation for beginning physical work within 3 hr. of notification. Emergency mobilization will be paid for in addition to pothole repair.

Item 712

Cleaning and Sealing Joints and Cracks (Asphalt Concrete)



1. DESCRIPTION

Clean and seal joints and cracks in asphalt concrete roadway surfaces.

2. MATERIALS

Furnish materials unless otherwise shown on the plans. Furnish sealant materials as shown on the plans in accordance with Item 300, "Asphalts, Oils, and Emulsions." Furnish fine aggregate in accordance with Section 340.2.1.3., "Fine Aggregate."

3. EQUIPMENT

Furnish equipment, tools, and machinery for proper execution of the work.

3.1. **Hot-Applied Sealants.** Heat in a double-jacketed heater using a heat transfer oil so no direct flame comes in contact with the shell of the vessel containing the sealing compound. Provide a heater capable of circulating and agitating the sealant during the heating process to achieve a uniform temperature rise and maintain the desired temperature. Provide gauges to monitor the temperature of the vessel contents and avoid overheating the material. Provide a heater equipped with a gear-driven asphalt pump with adequate pressure to dispense the sealant.

3.2. **Cold-Applied Sealants.** Provide equipment with adequate pressure to dispense the sealant in a continuous flow.

4. WORK METHODS

Apply material when the air or pavement temperature is within the manufacturer's recommendations or as approved. Clean and seal joints and cracks that are 1/16 in. or greater in width. Fill cracks with dry sand for cracks greater than 1/2 in. or as shown on the plans. Rout joints and cracks to the configuration shown on the plans when required. Clean joints and cracks with air blast cleaning or other acceptable methods to a depth at least twice the joint or crack width. Joints and cracks must be free of moisture before sealing. Dispose of materials removed as directed or approved. Apply sealing material with a pressure nozzle. Completely fill cracks and joints. Squeegee material to no more than 3 in. wide and 1/8 in. above the pavement surface. Prevent tracking with an application of fine aggregate as directed.

5. MEASUREMENT

This Item will be measured by the foot, gallon, pound, or lane mile. Shoulders wider than 6 ft. are considered additional lanes.

6. PAYMENT

The work performed and materials furnished in accordance with this Item and measured as provided under "Measurement" will be paid for at the unit price bid for "Joint and Crack Sealing" of the sealant material specified and "Joint and Crack Routing and Sealing" of the sealant material specified. This price is full

compensation for routing, cleaning, and sealing joints and cracks; furnishing and placing materials; and equipment, labor, tools, and incidentals.

If measurement is by the lane mile, shoulders 6 ft. or narrower will not be paid for directly but will be subsidiary to work on the adjacent travel lane.

Item 713

Cleaning and Sealing Joints and Cracks (Concrete Pavement)



1. DESCRIPTION

Clean and seal joints and cracks in concrete pavement.

2. MATERIALS

Furnish sealant, boards, and backer rods in accordance with DMS-6310, "Joint Sealants and Fillers." The sealant must be type 4, 5, 7, or 8 unless otherwise shown on the plans and specifications. Furnish primer when required by the sealant manufacturer.

3. EQUIPMENT

Use equipment that meets the sealant manufacturer's recommendations. Furnish equipment capable of placing the sealant, backer rods, and boards as detailed on the plans. Furnish equipment capable of removing all foreign material from the concrete joint or the grooved crack. The following equipment is recommended to meet cleaning and sealing requirements:

- Power Concrete Saw,
- Sandblasting Equipment,
- Power Router,
- High Pressure Air, and
- Sealant Dispenser.

4. WORK METHODS

Use dimensions shown for joint details in standard drawing *Concrete Paving Details, Joint Seals*, unless other dimensions are shown on the plans. Make a groove, follow the cracks to be sealed, and rout the groove approximately 1/2 in. deep × 5/8 in. wide, unless otherwise directed or shown on the plans. The Engineer will select joints and cracks to be cleaned and sealed.

Remove all foreign material from the joint or groove reservoir. Clean the joint by sandblasting or other approved methods. If directed, saw joint sides to remove embedded foreign material in the concrete that sandblasting will not remove. Do not place sealant when the concrete pavement is below 55°F or above 90°F. Do not place sealant in a wet or damp joint or groove. Use approved drying method if joints or grooves are sealed within 24 hours of rain. Apply primer when required by the sealant manufacturer. Blow out joint or groove with high pressure air or other approved methods before placing sealant. Remove and replace sealant when placed flush with or above the pavement surface. The different types of joints and cracks are described in Table 1.

Table 1
Types of Joints and Cracks Requirements

Joint or Crack Type	Requirement
Transverse Contraction Joints	Backer rods and sealants
Longitudinal Contraction Joint	Sealant
Longitudinal Construction Joint	Sealant
Expansion Joints	Boards, backer rods, and sealant
Cracks in Jointed Concrete Pavement	Sealant

5. MEASUREMENT

Joint cleaning and sealing will be measured by the foot of joint cleaned and sealed. Crack cleaning and sealing will be measured by the foot of crack cleaned and sealed.

6. PAYMENT

The work performed and materials furnished in accordance with this Item and measured in accordance with "Measurement" will be paid for at the unit price bid for "Joint Sealing and Cleaning" of the type specified, or "Crack Cleaning and Sealing."

Item 720

Repair of Spalling in Concrete Pavement



1. DESCRIPTION

Repair spalling and partial-depth failures in concrete pavement.

2. MATERIALS

Furnish either rapid-set concrete or polymeric patching material unless otherwise shown on the plans.

2.1. **Rapid-Set Concrete.** Provide concrete that meets DMS-4655, "Concrete Repair Materials," Type "B."

Use a packaged blend of hydraulic cement, sand, and gravel (maximum size 3/8 in.) which requires the addition of water and has a maximum shrinkage of 0.15% in accordance with ASTM C928.

Do not use chlorides, magnesium or gypsum to accelerate setting time.

Demonstrate that mixture achieves flexural strength of at least 425 psi in 5 hr., a minimum compressive strength of 5,100 psi in 7 days, and 6,300 psi in 28 days before spall repair operations. Test in accordance with Tex-418-A and Tex-448-A.

2.2. **Polymeric Patching Material.** Provide polymeric patching material that meets DMS-6170, "Polymeric Materials for Patching Spalls in Concrete Pavement," and matches the color of the pavement.

3. EQUIPMENT

Furnish equipment in accordance with Item 429, "Concrete Structure Repair," or as approved.

4. WORK METHODS

Repair areas as shown on the plans or as directed. Dispose of debris off the right of way in accordance with federal, state, and local regulations.

4.1. **Hydraulic Cement Concrete Material.** Saw at least 1-1/2 in. deep around repair area before concrete removal, unless otherwise directed, providing a vertical face around the perimeter of the repair area. Protect and reuse existing reinforcing if encountered, unless otherwise directed. Provide a uniform rough surface free of loose particles and suitable for bonding. Remove concrete to a depth of 1-1/2 in. or the depth of deteriorated concrete, whichever is greater. Use chipping hammers not heavier than the nominal 15-lb. class or hydrodemolition equipment for the removal of concrete below 1-1/2 in. depth. Mix, place, and cure in accordance with manufacturer's recommendations. Place concrete if the air temperature is 40°F or above. Screenshot concrete to conform to roadway surface. Provide a rough broom finish.

4.2. **Polymeric Patching Material.** Submit for approval a statement from the manufacturer identifying the recommended equipment and installation procedures. Remove the deteriorated concrete to the dimensions shown on the plans or as directed. Dry and abrasive blast the repair area to ensure it is free from moisture, dirt, grease, oil, or other foreign material that may reduce the bond. Remove dust from the abrasive blasting operation. Apply primer to the repair area in accordance with manufacturer's recommendations. Reapply primer if conditions change before placing patching material. Mix, place, and cure in accordance with manufacturer's recommendations. Begin placement of material at the lower end of sloped areas. Screenshot

polymeric patching material to conform to the roadway surface. Provide a non-skid finish with a notched trowel.

5. MEASUREMENT

This Item will be measured as follows:

- 5.1. **Hydraulic Cement Concrete Material.** By the cubic foot of concrete repair material placed.
- 5.2. **Polymeric Patching Material.** By the gallon of polymeric patching material placed.

6. PAYMENT

The work performed and materials furnished in accordance with this Item and measured as provided under "Measurement" will be paid for at the unit price bid for "Spalling Repair" of the type (Hydraulic Cement; Polymeric, Flexible; or Polymeric, Semirigid) specified. This price is full compensation for sawing, chipping, milling, cleaning, abrasive blasting, repairing spalled concrete pavement, disposal of materials, materials, equipment, labor, tools, and incidentals.

Item 721

Fiber Reinforced Polymer Patching Material



1. DESCRIPTION

Repair spalled areas, potholes, and joints on concrete and asphalt pavements using a fiber reinforced polymer patching material, bulking aggregates, and finishing aggregates as specified below.

2. DEFINITIONS

For the purposes of this specification, the following definitions apply:

- **Binder.** The thermal setting material that is the basis of the patching material, and to which any fillers, fibers, or other components are added.
- **Patching Material.** The binder and other additives, mixed together, and in the form that will be applied to the patch, not including bulking aggregate or final surface aggregate.
- **Bulking Aggregate.** Additional aggregate mixed with the patching material when using for repairs deeper than 1 in.
- **Finishing Aggregate.** Additional aggregate applied to the patch after the patching material has been applied.

3. MATERIALS

Provide a hot-applied patching material consisting of a combination of binder, polymers, graded fillers, aggregates, fibers, and rubber that once heated provides an impermeable, voidless solid mass at ambient temperatures. Formulate the patching material according to climatic conditions to provide a durable pavement repair with good fluidity at process temperature, low temperature flexibility, and ambient temperature flow resistance.

The binder may be liquid asphalt or polymer based, unless otherwise shown on the plans, and may be provided separately or premixed with the other components of the patching material. The patching material must meet the requirements of Table 1.

Table 1
Patching Material Properties

Property	Test Method	Requirement
Resilience	Tex-547-C	50% minimum
Tensile Strain to Failure	Tex-548-C	20% minimum
Tensile Stress at Failure	Tex-548-C	50 psi minimum
Cone Flow	Tex-549-C	12% maximum (asphalt based) 4% maximum (polymer based)
Flexibility	Tex-550-C	pass ¹
Settlement	Tex-551-C	3 mm, maximum

1. No evidence of cracking of the sample.

- 3.1. **Sampling and Testing.** Provide material that has been preapproved by the Department, in accordance with Tex-545-C, "Asphalt Binder Quality Program." Submit blended samples of patching material for preapproval or field evaluation.
- 3.2. **Bulking Aggregate.** Provide single-sized bulking aggregate consisting of a crushed, double-washed, and dried Type A Grade 1 aggregate in accordance with Item 302, "Aggregates for Surface Treatments," or equivalent.

Note—Patching material may be supplied with the bulking aggregate premixed, when shown on the plans. The Engineer may sample the material to determine the percentage by weight of bulking aggregate included.

- 3.3. **Final Surface Aggregate.** Provide final surface aggregate consisting of a crushed, double-washed, and dried Type A Grade 5 aggregate in accordance with Item 302, "Aggregates for Surface Treatments."

4. **WORK METHODS**

Install the patching material to fill the damaged or spalled areas as shown on the plans, with adjustments to the depth and width of the repairs as directed.

Use an applicator certified by the material manufacturer.

Remove all loose and damaged material from the repair area, either by saw-cutting around the area and using a jackhammer to remove material, or a milling machine, as approved. Remove material from the repair area to a depth and width necessary to provide sound pavement that will allow proper seating of the patching material.

- Use an approved jackhammer capable of performing the required removal of the existing material without further damaging the surrounding pavement. Use a jackhammer no larger than 30 pounds unless otherwise approved.
- Operate the milling machine in the longitudinal direction to provide a tapered edge in the direction of travel.

Thoroughly clean and dry substrate faces using a hot-compressed air lance.

Prime the area for concrete pavement using a primer determined by the manufacturer to prevent moisture intrusion.

Mix and heat the patching material on site in a horizontal mixing unit equipped with electronically controlled thermostats. Heat the bulking and final surface aggregates until dry and free of dust, using a vented barrel mixer or other approved method to 300°F.

Apply patching material to the repair area. If the repair area is deeper than 1 in., add bulking aggregate at a rate of 15%-30% by volume as directed. Install patching material in lifts to ensure uniform application for materials with the bulking aggregate premixed.

Install additional patching material and bulking aggregate in 1-in. lifts until the repair is level with the existing pavement.

Apply a final coat of the heated patching material to level the repair area.

Dress the surface of the patch with heated surface aggregate. Perform this operation while the patch is still hot.

Sweep the area and remove all debris from the site. Ensure the material has cooled where it does not permanently deform under pressure, as recommended by the manufacturer or as directed, before opening to traffic.

5. **MEASUREMENT**

This Item will be measured by the pound of patching material installed. If the bulking aggregate is supplied premixed with the patching material, discount the gross weight of material by the weight percentage of bulking aggregate included.

6. PAYMENT

The work performed and materials furnished in accordance with the Item and measured as provided under "Measurement" will be paid for at the unit price bid for "Fiber Reinforced Polymer Patching Material." This price is full compensation for furnishing materials, including bulking and final surface aggregates, patching material binder, and primer; heating and mixing; removal and disposal of existing pavement material; placing and finishing; labor, equipment, tools, and incidentals.

Item 730

Roadside Mowing



1. DESCRIPTION

Mow roadside vegetation.

2. EQUIPMENT

- 2.1. **Mowers.** Provide either rigid-frame mowers with a maximum cutting width of 9 ft. or batwing rotary mowers equipped with sharp blades to cleanly cut vegetation using deflection devices to prevent flying debris ejected by the mowers, unless otherwise shown on the plans.
- 2.2. **Emblems.** Provide slow-moving vehicle emblem affixed to rear of mowers.
- 2.3. **Warning Lights.** Provide highly visible omnidirectional amber flashing warning lights on tractors and work trucks.
- 2.4. **Trimmers.** Provide trimmers for hand trimming.
- 2.5. **Portable Pressure Washer.** Provide a portable pressure washer with a minimum operating pressure of 1,500 psi to wash mowing equipment when shown on the plans.

3. WORK METHODS

- 3.1. **Requirements.**
- Set mower cutting height 5 to 7 in. or as directed.
 - Perform mowing sequence as directed or approved.
 - Ensure wet ground is not mowed when rutting can occur, unless otherwise approved.
 - Do not mow designated non-mow areas.
 - Remove debris ejected onto the roadway immediately. Remove mowed grass from roadway when determined to be a hazard.
 - Hand-trim around fixed objects within mowed area. Complete hand trimming on each roadway within 24 hr. of mowing. Ensure trees and shrubs are not damaged.
 - Restore appurtenances damaged by mowing operations, in accordance with Article 7.17., "Contractor's Responsibility for Work."
 - Ensure stands of wildflowers are not mowed before seeds have matured, unless otherwise directed.
- 3.2. **Mowing Types.**
- 3.2.1. **Strip Mowing.**
- Mow a strip of vegetation along edge of pavement or unpaved shoulder, in accordance with details shown on the plans.
 - Mow to provide sight distance at horizontal curves, intersections, driveways, and ramps.
 - Mow to right of way line where specified.
 - Mow around appurtenances within the strip width.
 - Mow entire right of way under bridges and in drainage channels.

- Provide a 6 to 1 transition between the strip width and other areas requiring a different width.
- Mow the entire width of medians and outer separations (areas between mainlanes, ramps, and frontage roads), except for non-mow areas.

- 3.2.2. **Full-Width Mowing.** Mow vegetation in the entire right of way, except for non-mow areas.
- 3.2.3. **Spot Mowing.** Work requests are made on a callout basis. Begin mowing designated areas within 48 hr. of notification unless otherwise shown on the plans.
- 3.3. **Washing Mowing Equipment.** Pressure wash mowing equipment before the equipment enters or leaves designated areas shown on the plans. Notify the inspector before washing the equipment. The inspector will approve the washing locations so seed and plant material is contained.

4. MEASUREMENT

This Item will be measured by the acre.

- 4.1. **Strip and Full-Width Mowing.** "Strip Mowing" and "Full-Width Mowing" are plans quantity measurement items. The quantity to be paid is the quantity shown on the plans, unless modified by Article 9.2., "Plans Quantity Measurement." Additional measurements or calculations will be made if adjustments of quantities are required.
- 4.2. **Spot Mowing.** "Spot Mowing" will be measured by the acre mowed. The minimum quantity per callout is 3 acres, unless otherwise shown on the plans.

5. PAYMENT

The work performed and materials furnished in accordance with this Item and measured as provided under "Measurement" will be paid for at the unit price bid for "Strip Mowing," "Full-Width Mowing," or "Spot Mowing." This price is full compensation for furnishing and operating equipment; pressure washing; and materials, tools, and incidentals.

Item 731

Herbicide Treatment



1. DESCRIPTION

Apply herbicide to control undesirable vegetation within the highway right of way.

2. MATERIALS

Furnish herbicide materials in accordance with Chapter 3, Section 15 of the Department's *Roadside Vegetation Management Manual*, as shown on the plans or as approved. Furnish surfactant and blue dye made for herbicide as approved. Materials furnished by the Department will be shown on the plans.

3. LICENSE REQUIREMENTS

Possess either a Commercial Pesticide Applicator License from the Texas Department of Agriculture in the Right of Way (#5) category, or a Texas Structural Pest Control Service license in the Weed category. Provide the Department with documentation of license before beginning work. Conduct on-site supervision of all mixing, transporting, handling, spraying, and disposal of materials with licensed personnel.

4. RECORDS

Document work in accordance with all federal, state, and local regulations. Submit a copy of the herbicide records on the next business day following the application. Submit a final copy of all the herbicide application records upon completion of the Contract.

5. SEASON

Spray herbicide during active growing periods unless otherwise approved.

6. EQUIPMENT

Furnish all equipment.

- 6.1. **Broadcast Application.** Furnish self-propelled equipment, tractor mounted or pulled spray rigs with a low center of gravity that allows a safe traverse on a maximum 3:1 slope. Provide equipment capable of making uniform broadcast applications calibrated at a rate between 20 and 40 gallons per acre (GPA).
- 6.2. **Pavement Edges and Structures.** Provide spray equipment capable of spraying a pattern that will cover cracks and expansion joints in the entire pavement shoulder and a continuous band along the pavement's edge. Provide additional booms or nozzles capable of spraying under guardrails and around sign posts, luminaire poles, or other structures within 10 ft. of the pavement edge. Provide equipment capable of making uniform broadcast applications calibrated at a rate between 20 and 40 GPA.
- 6.3. **Handgun Applications.** Provide equipment with a handgun and enough hose to reach all fixtures on the right of way and capable of making applicable applications.
- 6.4. **Basil Bark and Cut Tree Applications.** Furnish sprayers with low volume spray tips (Spray Systems 5500 Adjustable Spray Tip X-1 or X-2, or approved equivalent).

- 6.5. **Wick Applications.** Furnish equipment capable of performing a uniform herbicide application while safely traversing a 3:1 slope and performing applications in variable heights ranging from 12 to 30 in. Use double coverage rope wicks capable of applying up to 5 GPA. Outfit equipment with components necessary to provide an adjustable, consistent flow of herbicide, but prevent undesired leakage of materials while transporting, storing, or making applications.
- 6.6. **Storage and Nurse Tanks.** Outfit equipment with components necessary to prevent undesired leakage of materials while transporting, storing, or making applications.
- 6.7. **All-Terrain Vehicles (ATVs) or Four-Wheel Utility Vehicles (FWUVs).** Use ATVs and FWUVs to expedite the work as approved. Operate ATVs and FWUVs on the right of way roadside complying with all state laws and regulations.
- 6.8. **Personal Protection Equipment.** Follow the manufacturer's label requirements for personal protection of employees.

7. WORK METHODS

Apply approved herbicide in accordance with the manufacturer's label recommendations, as shown on the plans or as approved. Add surfactant and blue dye marker at the manufacturer's recommended rate unless otherwise approved. Prepare herbicide solution to the rates shown on the plans using procedures on the herbicide container label. Mix herbicide solution under the direct supervision of Department personnel. Return any unused, Department-furnished herbicide to the Department. Dispose of empty containers and unused chemical mixtures in accordance with label directions and local, state, and federal regulations. **Cease spraying operations immediately when wind or other environmental conditions cause off-target spray drift, leaves are wet, or rainfall is imminent.** An inspection of the treated areas will be made not less than 14 days and no later than 30 days after the application. Re-treat areas in which the undesirable vegetation has not been controlled for no additional compensation. All applications made after October 1 will be inspected in May of the following year to determine if any re-treatment is required. Repair and replace any damaged desirable vegetation or erosion as a result of negligent applications.

- 7.1. **Broadcast Application.** Spray undesirable vegetation by broadcasting with spray nozzles at the desired rate. Spray from the pavement or roadside to reach the vegetation being controlled as approved. Ensure nozzles spray consistent across the area being covered.
- 7.2. **Pavement Edges, Structures, and Fixtures.** Apply herbicide to eliminate all grass and weeds encroaching into or on pavement mainlane, shoulder edges, riprap, and structures including retaining walls, sidewalks, islands, traffic barriers, raised medians, curbs, mow strips, and any other concrete or asphalt structure as shown on the plans, or as directed.
- 7.2.1. **Pavement.** Spray a band of herbicide on and along the outside edge of pavement surfaces and curbs wide enough to spray vegetation growing in the pavement or curbs and approximately 6 in. of vegetation off the pavement edge or behind the curb. Do not treat roadways adjacent to highly maintained or manicured landscapes, such as residential yards or parks, with herbicides.
- 7.2.2. **Guardrails and Cable Barriers.** Spray a band of herbicide approximately 18 in. wide under guardrails and cable barriers.
- 7.2.3. **Appurtenances (Retaining Walls, Sidewalks, Islands, Traffic Barriers, Mow Strips, Attenuators, etc.).** Spray a band of herbicide on and along the outside edge of appurtenances and approximately 6 in. of vegetation along or around the fixture.
- 7.2.4. **Supports (Signs Supports, Luminaire Poles, Mail Box Supports, etc.).** Spray a 12-in. wide band around and on all sides of the base of sign posts, luminaire poles, mail box supports, or other roadside hardware within 10 ft. of the pavement edge.

- 7.2.5. **Handgun Applications.** Use a handgun to spray structures inaccessible to spray with boom mechanized spray equipment.
- 7.3. **Basal Bark Treatment.** Apply herbicide solution with a low-volume, low-pressure sprayer which thoroughly wets the lower 12–15 in. of stems on all sides, including the root collar area, but not to the point of run-off. Perform applications at any time throughout the year, except when the stems and/or stumps are wet from rainfall or dew or snow prevents spraying to the base of the plant.
- 7.4. **Cut-Stump Treatment.** Cut plants parallel to the ground, not to exceed 2 in. above the ground line. Apply the herbicide solution with a low-volume, low-pressure sprayer which thoroughly wets the area adjacent to the cambium and bark around the entire circumference of the stump. Thoroughly wet the sides of the stump, but not to the point of run-off. Make the herbicide application within 1 hr. from the time each plant is cut. Dispose of removed materials and debris at locations off the right of way in accordance with local, state, and federal requirements.
- 7.5. **Wick Application.** Apply herbicide to targeted vegetation within the full width of right of way, excluding areas as shown on the plans, by wiping the rope wick applicator across the vegetation at a constant rate in a smooth manner. Adjust wick height to achieve the control of only the targeted weeds. Apply herbicide only to target weed species as shown on the plans, or as directed. Replace any desirable trees, shrubs, wildflowers, or grasses damaged by negligent applications. Re-treat all target weeds not controlled after 15 days until weeds are controlled.

Pressure wash all herbicide application equipment before beginning work and again before leaving the jobsite to remove any weed seed on equipment. Notify inspector before washing the equipment and wash equipment in an approved area.

8. MEASUREMENT

This Item will be measured by the lump sum, centerline mile, or acre.

9. PAYMENT

The work performed and materials furnished in accordance with this Item and measured as provided under "Measurement" will be paid for at the unit price bid for "Broadcast Application," "Pavement Edges, Structures and Fixtures," "Basal Bark Herbicide Treatment," "Basal Bark Herbicide Treatment (Cut Stump)," or "Wick Application of Herbicide." A partial payment of 50% of the unit price bid will be paid after the initial application is performed. The final 50% of the unit price bid will be paid after the inspection and required re-treatments have been completed and accepted. This price is full compensation for herbicide application and furnishing equipment, materials, labor, tools, re-treatment, and incidentals.

Item 734

Litter Removal



1. DESCRIPTION

Remove and dispose of litter, including objects not part of the highway facility, such as trash, garbage, scrap metal, paper, wood, plastic, glass products, animal remains, rubber products, tires, auto parts, furniture, mattresses, household appliances, and large bulky items.

2. MATERIALS

Furnish bags and containers.

3. EQUIPMENT

Provide equipment and tools. Provide highly visible omni-directional amber flashing warning lights on work vehicles. Provide equipment that prevents the accumulated debris from being strewn along the roadway during transport.

4. WORK METHODS

Remove bagged litter on the same day it is collected. Notify the Department for removal of dead animals larger than 150 lb. or hazardous materials. Dispose of litter off the right of way in accordance with federal, state, and local regulations. Perform litter removal and disposal according to the following types.

- 4.1. **Litter.** Remove and dispose of litter from the right of way, including shoulders but excluding the traveled lanes and shoulders next to barriers, to the limits shown on the plans.
- 4.2. **Spot Litter.** Work requests are made on a callout basis. Begin removing litter within 3 hr. of notification, unless otherwise shown on the plans.

5. MEASUREMENT

This Item will be measured as follows:

- 5.1. **Litter.** By the cycle or acre.
- 5.2. **Spot Litter.** By the acre. The minimum quantity per callout is 3 acres, unless otherwise shown on the plans.

6. PAYMENT

The work performed and materials furnished in accordance with this Item and measured as provided under "Measurement" will be paid for at the unit prices bid for "Litter Removal" or "Litter Removal (Spot)." This price is full compensation for collecting, hauling, and disposing of litter; and for equipment, labor, materials, tools, and incidentals.

Item 735

Debris Removal



1. DESCRIPTION

Remove and dispose of debris discarded or deposited on or adjacent to the pavement. Debris includes all objects not part of the highway facility, such as dead animals, tires, tire fragments, wood, furniture, mattresses, household appliances, and scrap metal.

2. EQUIPMENT

Provide highly visible omni-directional flashing warning lights on work vehicles. Provide equipment that prevents the accumulated debris from being strewn along the roadway during transport.

3. WORK METHODS

Remove debris at locations shown on the plans. Notify the Department for removal of hazardous materials. Dispose of debris off the right of way in accordance with applicable federal, state, and local regulations.

- 3.1. **Center Medians and Mainlanes.** Remove and dispose of debris from the main travel lanes, paved medians, paved shoulders, and an additional 5 ft. adjacent to the pavement, unless otherwise shown on the plans.
- 3.2. **Frontage Roads.** Remove and dispose of debris from frontage roads, shoulders, U-turn lanes, and intersecting streets to the right of way, including turn lanes, underpasses and overpasses, and an additional 5 ft. adjacent to the pavement, unless otherwise shown on the plans.
- 3.3. **Entrance and Exit Ramps.** Remove and dispose of debris from ramps, shoulders, and an additional 5 ft. adjacent to the pavement, unless otherwise shown on the plans.
- 3.4. **High Occupancy Vehicle (HOV) Lane.** Remove and dispose of debris from HOV lanes including HOV ramps. The HOV lanes are defined as:
 - 3.4.1. **Barrier-Separated Contraflow Lane.** Barrier-separated contraflow lane(s) is defined as a lane enclosed by two physical barriers.
 - 3.4.2. **Buffer-Separated Concurrent Flow Lane.** Buffer-separated concurrent flow lane is separated from general purpose lanes by a striped buffer zone and is defined as the left or inner most lane identified by signing and diamond symbols on the pavement.
- 3.5. **Direct Connector Ramp Debris Removal.** Remove and dispose of debris from the shoulders and paved gutters of direct connector ramp.
- 3.6. **Spot Debris Removal.** Work requests are made on a callout basis. Remove and dispose of debris as directed. Begin removing debris within 3 hr. of notification, unless otherwise shown on the plans.

4. MEASUREMENT

This Item will be measured as follows:

- 4.1. **Center Medians and Mainlanes, Frontage Roads, and Entrance and Exit Ramps.** By the cycle or right of way centerline mile. A right of way centerline mile is defined as the distance from beginning reference marker location to ending reference marker location, regardless of the number of roadbeds.
- 4.2. **HOV Lane Debris Removal.** By the cycle or HOV lane centerline miles. HOV lane centerline mile is defined as the distance measured along each HOV lane regardless of the number of lanes.
- 4.3. **Direct Connector Ramp Debris Removal.** By the cycle or direct connector ramp centerline mile. A direct connector centerline mile is defined as the distance measured along each direct connector regardless of the number of lanes.
- 4.4. **Spot Debris Removal.** By the roadbed mile. The minimum quantity per callout is 1 roadbed mile, unless otherwise shown on the plans.

5. PAYMENT

The work performed and materials furnished in accordance with this Item and measured as provided under "Measurement" will be paid for at the unit prices bid for "Debris Removal" of the type and cycle location specified. This price is full compensation for collecting, hauling and disposing of debris, and for equipment, labor, materials, tools, and incidentals. Traffic control will not be paid for directly but will be subsidiary to this Item, unless otherwise shown on the plans.

Debris removal in buffer-separated concurrent flow lanes is considered subsidiary to debris removal in center medians and mainlanes, unless otherwise shown on the plans.

Debris removal required for work orders issued under Item 734, "Litter Removal," or Item 738, "Cleaning and Sweeping Highways," will be subsidiary to that Item unless otherwise shown on the plans.

Item 738

Cleaning and Sweeping Highways



1. DESCRIPTION

Clean and sweep highway facilities.

2. EQUIPMENT

Furnish equipment and tools capable of dislodging crusted debris from road surfaces, removing and collecting materials from roadway. Provide highly visible omni-directional flashing warning lights on work vehicles. Furnish equipment with a water tank and adequate spray assemblies for dust control, and a dirt hopper with enough capacity to allow progress with minimum interference to traffic. Provide other types of cleaning and sweeping equipment, including hand tools, when required.

3. WORK METHODS

Completely remove debris from pavement surfaces and other areas designated on the plans, such as all sides of raised pavement markers, barrier drain slots, slotted drains, inlet openings, attenuators, and guardrails. Notify the Department for removal of hazardous materials. Debris is defined as dirt and other objects not part of the highway facility including dead animals, tires, tire fragments, wood, furniture, mattresses, household appliances, and scrap metal. Collect the debris and dispose of it off the right of way in accordance with federal, state, and local regulations. Ensure debris is not swept or blown onto traffic lanes. The types of cleaning and sweeping are as follows:

- 3.1. **Center Median Cleaning and Sweeping.** Clean and sweep the paved center medians or left-paved shoulders and left-paved gutters.
- 3.2. **Outside Mainlane Cleaning and Sweeping.** Clean and sweep the outside lanes or right-paved shoulders and right paved gutters. Clean and sweep intersecting streets to the right of way line.
- 3.3. **Frontage Road Cleaning and Sweeping.** Clean and sweep the right- and left-paved shoulders and paved gutters on all frontage roads. Clean and sweep U-turn lanes and intersecting streets to the right of way line, including turn lanes, underpasses, and overpasses.
- 3.4. **Entrance and Exit Ramp Cleaning and Sweeping.** Clean and sweep right- and left-paved shoulders and paved gutters of ramps.
- 3.5. **Direct Connector Cleaning and Sweeping.** Clean and sweep the right and left paved shoulders and paved gutters of direct connectors.
- 3.6. **HOV Lane Cleaning and Sweeping.** Clean and sweep HOV lanes, bridges and ramps.
- 3.7. **Aggregate Removal.** Clean and remove aggregate from designated areas following adverse weather conditions.
- 3.8. **Spot Sweeping.** Work requests are made on a callout basis. Clean and sweep roadways in designated areas. Begin sweeping within 3 hr. of notification, unless otherwise shown on the plans.
- 3.9. **Handwork.** Clean and sweep areas as shown on the plans or as directed.

4. MEASUREMENT

Right of way centerline mile is defined as the distance measured from the beginning point to the ending point shown on the plans and is measured once regardless of the number of lanes or roadbeds.

Ramp centerline mile is defined as the distance measured along each ramp regardless of the number of lanes. A roadbed mile is defined as the distance along each roadbed regardless of the number of lanes.

HOV lane centerline mile is defined as the distance measured along each HOV lane regardless of the number of lanes. A direct connector centerline mile is defined as the distance measured along each direct connector regardless of the number of lanes.

Types of cleaning and sweeping will be measured as follows:

- 4.1. **Center Median.** By the cycle or right of way centerline mile.
- 4.2. **Outside Mainlane.** By the cycle or right of way centerline mile.
- 4.3. **Frontage Road.** By the cycle or right of way centerline mile.
- 4.4. **Entrance and Exit Ramp.** By the cycle or ramp centerline mile.
- 4.5. **HOV Lane Cleaning and Sweeping.** By the cycle or HOV lane centerline mile.
- 4.6. **Direct Connector Cleaning and Sweeping.** By the cycle or direct connector centerline mile.
- 4.7. **Aggregate Removal.** By the roadbed mile.
- 4.8. **Spot.** By the roadbed mile. The minimum quantity per callout is 1 roadbed mile, unless otherwise shown on the plans.
- 4.9. **Handwork.** By the square yard.

5. PAYMENT

The work performed and materials furnished in accordance with this Item and measured as provided under "Measurement" will be paid for at the unit price bid for "Cleaning and Sweeping" of the type and cycle location specified. This price is full compensation for cleaning, sweeping, collecting, hauling and disposing of debris, and for equipment, labor, materials, tools, and incidentals.

When work requests include multiple bid items and overlap occurs, the measurement and payment priority will be determined by the order shown in "Measurement."

Cleaning of items such as raised pavement markers, barrier drain slots, slotted drains, inlet openings, and areas adjacent to attenuator and guardrail supports will not be paid for directly but will be subsidiary to this Item unless otherwise shown on the plans.

Item 740

Graffiti Removal and Anti-Graffiti Coating



1. DESCRIPTION

Remove graffiti or apply anti-graffiti coating on concrete or steel.

2. MATERIALS

Furnish acrylic latex paint meeting the requirements of Item 446, "Field Cleaning and Painting Steel," for steel structures. Furnish concrete paint or opaque sealer in accordance with Item 427, "Surface Finishes for Concrete," for concrete structures unless otherwise shown on the plans. Furnish anti-graffiti coating of the type specified, in accordance with DMS-8111, "Anti-Graffiti Coatings." Furnish graffiti removal chemicals as approved.

3. WORK METHODS

Graffiti is defined as inscriptions or drawings placed on fixtures, structures, riprap, etc. Remove graffiti from signs as directed.

Work requests are made on a callout basis. Begin graffiti removal within 24 hr. of notification, unless otherwise shown on the plans.

Shape treated area to a rectangular configuration. Control dust or water to prevent a hazard to traffic. Ensure treated areas exhibit a uniform clean appearance upon completion. Follow the manufacturer's recommendations and use a low-pressure (less than 1,000 psi) water wash when using a chemical cleaning method.

3.1. **Graffiti Removal.** Remove graffiti by any of the following methods as specified:

3.1.1. **Surfaces without Anti-Graffiti Coating.**

■ **Concrete Structures.**

- **Blast Cleaning.** Use abrasive blasting, water blasting, or steam cleaning.
- **Chemical Cleaning.** Follow the manufacturer's recommendations.
- **Painting.** Prepare surface by approved methods before painting. Paint over the graffiti on concrete in accordance with Item 427, "Surface Finishes for Concrete." Match the color of the existing surface.

■ **Metal Surfaces.**

- **Painted Surfaces.** Prepare surface as approved. Paint over the graffiti on metal in accordance with Item 446, "Field Cleaning and Painting Steel." Match the color of the existing surface.
- **Galvanized or Unpainted Surfaces.** Use chemical cleaning.

3.1.2. **Surfaces with Anti-Graffiti Coating.** Fully remove graffiti as described below without damaging the anti-graffiti coating. Repair any damage to the anti-graffiti coating without additional cost to the Department.

- **Anti-Graffiti Coating, Type II (Solvent-Cleanable).** Use solvents or chemical cleaning to fully remove graffiti without damaging the anti-graffiti coating. Use a low-pressure water rinse as desired for a final wash of the cleaned surface.

- **Anti-Graffiti Coating, Type III (Water-Cleanable).** Use water and scrubbing or a low-pressure water wash (less than 1,500 psi at the surface) to fully remove graffiti without damaging the anti-graffiti coating.

Note—Overly high pressures or overly hard brushes will damage the anti-graffiti coating.

- 3.2. **Application of Anti-Graffiti Coating.** Blast clean all concrete surfaces in accordance with Item 427, “Surface Finishes for Concrete,” to remove old coatings, laitance, curing compound, dirt, grime, and other contaminants.

Apply a primer, when required by the manufacturer, in accordance with the manufacturer’s recommendations.

Apply anti-graffiti coatings on surfaces specified on the plans. Anti-graffiti coatings require a dry surface. Apply anti-graffiti coatings when the temperature of the atmosphere, substrate surface, and material is 50°F or above. Ensure anti-graffiti coatings are not applied when impending weather conditions might result in injury to the fresh coating. Ensure anti-graffiti coatings are not applied over any existing appearance coating unless otherwise shown on the plans.

Apply anti-graffiti coatings by spray, roller, or brush at the application rates recommended by the manufacturer. Ensure the anti-graffiti coating is not thinned without prior approval. Replace anti-graffiti coatings not meeting a methyl ethyl ketone rub test when tested in accordance with ASTM D4752.

4. MEASUREMENT

This Item will be measured by the square foot. The minimum quantity per callout is 50 sq. ft. unless otherwise shown on the plans.

5. PAYMENT

The work performed and materials furnished in accordance with this Item and measured as provided under “Measurement” will be paid for at the unit price bid for “Graffiti Removal (Blast Cleaning),” “Graffiti Removal (Painting),” “Graffiti Removal (Chemical Cleaning),” “Anti-Graffiti Coating (Permanent-Type II),” and “Anti-Graffiti Coating Permanent- Type III).” This price is full compensation for cleaning, painting, equipment, labor, materials, tools, and incidentals.

Item 745

Picnic Area Maintenance



1. DESCRIPTION

Perform janitorial and grounds maintenance at picnic areas.

2. MATERIALS

Furnish materials and supplies unless otherwise shown on the plans. Obtain approval of materials before use.

3. WORK METHODS

The number and location of picnic areas, work days, frequency of maintenance, and other scheduled work items will be as shown on the plans, or as directed.

Report any needed repairs or vandalism when discovered. Secure "Lost and Found" items and report items found daily. Ensure tips or other gratuities are not accepted.

3.1. **Janitorial Maintenance.** Perform the following work on Mondays, Wednesdays, and Fridays for picnic areas unless otherwise shown on the plans:

- Clean tables, benches, concrete pads, arbors, barbecue pits, fire boxes, and other outdoor appurtenances.
- Clean soiled or stained items with an approved cleaner or disinfectant. Rinse thoroughly with clean water. Apply disinfectant to tables or benches only when surfaces can be rinsed immediately. Ensure brushes or cloths used to clean restrooms are not used to clean tables or benches.
- Remove graffiti immediately in accordance with Item 740, "Graffiti Removal and Anti-Graffiti Coating," except for measurement and payment. Display "Caution Wet Paint" signs if graffiti is painted over.
- Remove spider webs, wasp nests, etc.
- Clean slabs, walks, and driveways.
- Keep sidewalks and grounds free of litter including, but not limited to trash, garbage, scrap metal, paper, wood, plastic, glass products, bottle caps, ring-pull tabs, cigarette butts, chewing gum, feces, and animal remains.
- Empty trash receptacles and replace liners. Clean trash receptacles periodically as directed. Obtain approval for on-site temporary storage of collected trash. Dispose of collected trash off the right of way in accordance with federal, state, and local regulations.

3.2. **Grounds Maintenance.** Perform grounds maintenance at the frequency shown on the plans, or as directed.

3.2.1. **Mowing, Edging, and Trimming.** Pick up litter before mowing. Mow areas shown on the plans as directed. Set mower cutting height at 2 to 3 in. or as directed. Use push-type lawn mowers or hand-held trimmers around trees, arbor units, and other appurtenances when required. Use tractor-driven mowers in other areas, if approved. Ensure trees or other vegetation are not damaged. Replace vegetation damaged by improper operations. Edge sidewalks, arbor units, curbs, and concrete pavement. Trim around buildings, trees, shrubs, light poles, trash receptacles, sign posts, guard posts, delineator posts, culvert headwalls, ground lights, plant beds, and other appurtenances. Remove all dirt and trimmed vegetation from curbs, walks, slabs, and parking areas. Remove weeds, grass, and other undesirable growth from plant beds and shrubs. Remove and dispose of clippings, cutting windrows, and piles as directed.

- 3.2.2. **Watering.** Water grass, trees, and shrubs during the early morning hours at the frequency shown on the plans or as directed.
- 3.2.3. **Tree Pruning and Leaf Removal.** Prune dead and undesirable growth from trees and shrubs, as needed or directed. Remove and dispose of tree clippings, limbs, leaves, and pine needles as shown on the plans or as directed.
- 3.2.4. **Fertilizing.** Fertilize as shown on the plans.

4. MEASUREMENT

- 4.1. **Janitorial Maintenance.**
- **Picnic Areas.** By the month or by the cycle.
- 4.2. **Grounds Maintenance.**
- **Mowing and Trimming.** By the cycle or acre.
 - **Tree Pruning and Leaf Removal.** By the cycle.

5. PAYMENT

The work performed and materials furnished in accordance with this Item and measured as provided under "Measurement" will be paid for at the unit prices bid for "Janitorial Maintenance (Picnic Areas)," "Grounds Maintenance (Mowing and Trimming)," and "Grounds Maintenance (Tree Pruning and Leaf Removal)." Site numbers will be specified corresponding to the detail location description on the plans when multiple sites are bid separately. This price is full compensation for furnishing and operating equipment; for removal and disposal of pruning, limbs, clippings, leaves, and trash; and for labor, materials, tools, and incidentals.

Watering and fertilizing will not be paid for directly but will be subsidiary to the grounds maintenance mowing work.

Graffiti removal and anti-graffiti coating will not be paid for directly but will be subsidiary to the janitorial maintenance Item.

If payment is by the month, for any day when janitorial maintenance services are not satisfactorily completed, one day's pay will be deducted from the Contractor's monthly payment. One day's pay will be determined by dividing the monthly bid price by 30 days.

Item 751

Landscape Maintenance



1. DESCRIPTION

Perform landscape maintenance, litter pickup, mowing and edging, and irrigation repair of landscaped areas.

2. MATERIALS

Furnish materials in accordance with Article 193.2., "Materials," unless otherwise shown on the plans.

3. WORK METHODS

Perform landscape maintenance as follows in designated areas at the frequency shown on the plans, or as directed. Dispose of any debris off the right of way in accordance with federal, state, and local regulations.

- 3.1. **Fertilizer Application.** Apply fertilizer at the specified locations, at the analysis, times, and rate of application shown on the plans.
- 3.2. **Herbicide Application.** Comply with license requirements in Section 193.3.1., "Plant Maintenance." Control undesirable vegetation in riprap areas, plant beds, tree areas, and other locations by application of herbicide using manufacturers' recommendations, as directed. Remove dead plant debris.
- 3.3. **Irrigation System Operation and Repair.** Perform irrigation system work under the supervision of a person possessing an irrigator's license issued by the TCEQ, and provide documentation of this license. Repair deficiencies as shown on the plans. Perform backflow preventer testing as necessary or as directed. Ensure all zones are functioning properly and providing adequate moisture to maintain healthy plants using an approved watering schedule. Winterize the system to prevent freeze damage when shown on the plans. Repair system using replacement parts of the same type and manufacturer as originally installed or approved equal. Provide plant irrigation by an approved alternate method at no cost to the Department if the system fails due to the Contractor's actions or neglect.
- 3.4. **Leaf Removal.** Remove and dispose of tree clippings, limbs, leaves, and pine needles as shown on the plans or as directed.
- 3.5. **Litter Pickup.** Pick up litter in accordance with Item 734, "Litter Removal."
- 3.6. **Mowing, Trimming, and Edging.** Mow and trim in accordance with Section 745.3.2., "Grounds Maintenance," and Item 730, "Roadside Mowing," as approved.
- 3.7. **Mulching and Reshaping of Plant Beds.** Reshape plant basins and beds. Apply and maintain mulch to a minimum depth of 2 in., unless otherwise shown on the plans. Areas and species to be mulched will be shown on the plans.
- 3.8. **Plant Bed Maintenance.** Physically remove weeds and undesirable grasses, including their root systems, from within plant beds. Trim ground covers and perform additional maintenance to plants within plant beds as required on the plans.
- 3.9. **Pruning.** Prune and trim shrubs, bushes, and trees in accordance with ANSI A300.

- 3.10. **Vegetative Watering.** Water areas not containing irrigation systems, as shown on the plans. Provide adequate moisture to maintain healthy plants. Haul water to locations where there is no municipal supply or well.

4. MEASUREMENT

This Item will be measured as follows:

- 4.1. **Fertilizer Application.** By the cycle.
- 4.2. **Herbicide Application.** By the cycle.
- 4.3. **Irrigation System Operation and Repair.** By the month.
- 4.4. **Leaf Removal.** By the cycle.
- 4.5. **Litter Pickup.** By the acre or by the cycle.
- 4.6. **Mowing, Trimming, and Edging.** By the acre or by the cycle.
- 4.7. **Mulching and Reshaping of Plant Beds.** By the cycle.
- 4.8. **Plant Bed Maintenance.** By the cycle.
- 4.9. **Pruning.** By the cycle.
- 4.10. **Vegetative Watering.** By the thousand gallons of water hauled or by the month.

5. PAYMENT

The work performed and materials furnished in accordance with this Item and measured as provided under "Measurement" will be paid for at the unit prices bid for "Fertilizer Application," "Herbicide Application," "Irrigation System Operation and Repair," "Leaf Removal," "Litter Pickup," "Mowing, Trimming, and Edging," "Mulching and Reshaping of Plant Beds," "Plant Bed Maintenance," "Pruning," and "Vegetative Watering" at locations specified.

This price is full compensation for equipment, labor, materials, tools, and incidentals.

Disposal of debris, leaves, dead plants, and trees will not be paid for directly but will be subsidiary to pertinent Items.

Item 752

Tree and Brush Removal



1. DESCRIPTION

Remove and dispose of trees, brush, shrubs, and vines. Trim trees and shrubs. Remove stumps.

2. MATERIALS

Furnish commercially available pruning paint.

3. EQUIPMENT

Provide equipment necessary to complete the work.

4. WORK METHODS

Perform tree and brush removal and trimming from right of way line to right of way line or other widths and locations shown on the plans. Ensure trees, shrubs, and other landscape features that are to remain are not damaged. Dispose of debris within 48 hr. of cutting, off the right of way, in accordance with federal, state, and local regulations unless otherwise approved. When approved, chip debris and spread in a thin layer on the right of way.

4.1. **Tree Removal.** Remove trees of various diameters as shown on the plans, or as directed. Remove tree stumps to at least 12 in. below the surrounding terrain unless otherwise shown on the plans, or as directed. Backfill holes with acceptable material and compact flush with surrounding area.

4.2. **Tree Trimming.** Remove dead tree limbs. Remove tree limbs to the limits shown on the plans. Prune trees in accordance with Class IV National Arborist Association Pruning Standards for shade trees. Make cuts as close as possible to the trunk or parent limb without cutting into the branch collar or leaving a protruding stub. Remove suckers to the height of the lowest main branch.

When removing limbs 2 in. in diameter or larger:

- Undercut 1/3 way through the limb 8 to 12 in. from the main stem.
- Remove limb 4 to 6 in. outside the first cut.
- Remove stub with an even flush cut so that a trace (collar) protrudes approximately 1/2 in.
- Do not allow limb to fall free if it can damage other limbs or items.
- Treat exposed cuts on oak trees with wound dressing within 20 min. of the cut.

Disinfect tools with 70% methyl alcohol, benzalkonium chloride, chlorine solution, or other approved disinfectant when trimming oak trees and when shown on the plans before cutting, and sterilize/sanitize again before cutting another tree. Avoid pruning between February 15 and June 15, the period for maximum insect and fungal activity.

4.3. **Brush Removal.** Remove brush including, but not limited to, bushes, small trees, and vines growing within the right of way by cutting parallel to and within 1 in. of the ground and to the limits shown on the plans. Remove brush from under bridges, around culverts, and in channels to the limits shown on the plans.

4.4. **Channel Work.** Trim trees and remove brush to the limits shown on the plans, including areas under bridges.

- 4.5. **Stump Removal.** Remove tree stumps at least 12 in. below the surrounding terrain unless otherwise shown on the plans, or as directed. Backfill holes with acceptable material and compact flush with surrounding area.

5. MEASUREMENT

This Item will be measured as follows:

- 5.1. **Tree Removal.** By each tree of the diameter specified. The diameter will be measured 3 ft. above the ground. Trees less than 4 in. in diameter are considered brush. Trees with multiple trunks at the point of measurement will be measured separately and paid for according to the specified diameter. Removal of the stump is subsidiary to Tree Removal.
- 5.2. **Tree Trimming and Brush Removal.** By the centerline mile of the dimension specified. "Centerline mile" is defined as the continuous measurement along the center of the right of way.
- 5.3. **Tree Trimming and Brush Removal for Channels.** By the acre.
- 5.4. **Stump Removal.** By each stump removed. This item is for stumps where others previously removed the tree.

6. PAYMENT

The work performed in accordance with this Item and measured as provided under "Measurement" will be paid for at the unit price bid for "Tree Removal" of the diameter specified, "Tree Trimming" of the dimension specified, "Brush Removal," "Tree Trimming and Brush Removal," and "Stump Removal." This price is full compensation for removal, trimming, disposal, equipment, traffic control, labor, and incidentals.

When not shown on the plans as a separate pay item, payment for tree trimming and brush removal in channels will be included in payment by the centerline mile. When shown on the plans as a separate pay item, tree trimming and brush removal in channels will be paid for at the unit price bid for "Tree Trimming and Brush Removal (Channels)."

The limits shown on the plans are the limits for pay purposes unless otherwise modified in accordance with Article 4.4., "Changes in the Work."

Item 760

Cleaning and Reshaping Ditches



1. DESCRIPTION

Clean and reshape ditches.

2. WORK METHODS

Excavate and remove excess material from ditches and from around fixtures within the limits of the excavation or reshape by cleaning silt from the ditch and spreading on backslope as approved. Reshape ditches in conformance with the lines, grades, and typical cross-sections shown on the plans, or as directed. Dispose of excess material in accordance with applicable federal, state, and local regulations, or place on right of way, as directed. Maintain ditch drainage during cleaning and reshaping work.

3. MEASUREMENT

Measurement will be as follows:

- 3.1. **Foot.** By the foot, measured along the centerline of the ditch.
- 3.2. **Cubic Yard in Place.** By the cubic yard in its original position computed by the method of average end areas.
- 3.3. **Cubic Yard in Vehicle.** By the cubic yard in vehicles measured at the point of excavation.

4. PAYMENT

The work performed in accordance with this Item and measured as provided under "Measurement" will be paid for at the unit price bid for "Ditch Reshaping (Foot)," "Ditch Cleaning and Reshaping (Cubic Yard in Place)," or "Ditch Cleaning and Reshaping (Cubic Yard in Vehicle)." This price is full compensation for excavation, disposal of removed materials, reshaping, equipment, labor, tools, and incidentals.

Item 764

Pump Stations and Drainage System Cleaning



1. DESCRIPTION

Perform hydraulic cleaning, vacuum removal and disposal of debris in drain inlets, pump station wells, basket and inlet pipes, downspouts, sumps, storm sewers, and slotted drains. Debris is defined as dirt and other material not part of the drainage system.

2. MATERIALS

Furnish materials unless otherwise shown on the plans. Furnish water that is free of industrial waste and other objectionable material.

3. EQUIPMENT

Provide a vacuum truck (self-contained, single-unit vehicle with a high-pressure water pump capable of pumping at least 60 gpm at 2,000 psi with at least 500 ft. of hose and a water storage tank with at least 1,300-gal. capacity) or as approved. Provide a debris storage bin of at least 14-cu. yd. capacity and an air conveying vacuum system capable of cleaning pump station wells up to 55 ft. deep through 8-in. diameter tubing for pump station well, basket and inlet pipe cleaning, or if required by the plans.

4. WORK METHODS

Remove and dispose of debris and wash water off the right of way in accordance with federal, state, and local regulations.

Perform hydraulic cleaning and vacuum removal as follows:

- 4.1. **Drain Inlet.** Clean the drain inlet including the top. Drain inlet cleaning includes cleaning curb inlets, grate inlets, catch basins, or manholes.
- 4.2. **Pump Station Well.** Clean the pump well floor, excluding the basket and inlet pipes.
- 4.3. **Basket and Inlet Pipe.** Clean the basket and inlet pipes at the pump station well. Clean inlet pipes for a minimum distance of 10 ft. from inlet pipe entry into the well unless otherwise shown on the plans.
- 4.4. **Downspout.** Clean downspouts from the drain inlet on the bridge deck to the junction box, manhole, storm sewer trunk system, or outfall.
- 4.5. **Sump.** Clean the sump box.
- 4.6. **Storm Sewer.** Clean storm sewer pipe or box culvert, regardless of size or shape, for the distance required.
- 4.7. **Slotted Drain.** Clean the slotted drain, including the drainpipe below the slot. Clean the drainpipe from the downstream end of the slotted drain to the pipe outfall or to the next slotted drain in accordance with Section 764.4.6., "Storm Sewer."

5. MEASUREMENT

This Item will be measured by the each or foot as follows:

- 5.1. **Drain Inlet.** By each drain inlet cleaned.
- 5.2. **Pump Station Well.** By each pump station well cleaned.
- 5.3. **Basket and Inlet Pipe.** By each basket and inlet pipe cleaned.
- 5.4. **Downspout.** By each downspout cleaned.
- 5.5. **Sump.** By each sump cleaned.
- 5.6. **Storm Sewer.** By the foot of storm sewer pipe or box culvert cleaned, as measured by the hose extended into the pipe or culvert.
- 5.7. **Slotted Drain.** By the foot of drain measured along the slot. Cleaning of the drainpipe from the downstream end of the slotted drain to the pipe outfall or to the next slotted drain will be measured by the foot of hose extended into the drainpipe.

6. PAYMENT

The work performed and materials furnished in accordance with this Item and measured as provided under "Measurement" will be paid for at the unit price bid for "Drain Inlet Cleaning," "Pump Station Well Cleaning," "Basket and Inlet Pipe Cleaning," "Downspout Cleaning," "Sump Cleaning," "Storm Sewer Cleaning" of the type and size specified, and "Slotted Drain Cleaning." This price is full compensation for cleaning, removing and disposing of debris and wash water, equipment, labor, materials, tools, and incidentals.

Item 770

Guard Fence Repair



1. DESCRIPTION

Repair guard fence elements, posts, terminal anchor sections, single guard fence terminals, and other appurtenances.

2. MATERIALS

Furnish the following materials, unless otherwise shown on the plans:

- rail elements, posts, blockouts, fittings, and anchor concrete meeting Item 540, "Metal Beam Guard Fence;"
- single guardrail terminal (SGT), in accordance with Item 544, "Guardrail End Treatments;"
- steel posts with base plates or terminal anchor posts to match original design, meeting ASTM A36 or better;
- paint as required;
- concrete for structural repair, in accordance with Item 429, "Concrete Structure Repair;"
- grout meeting the requirements of Item 421, "Hydraulic Cement Concrete;" and
- backfill material as approved.

Pick up materials furnished by the Department at the locations shown on the plans. Load and deliver furnished material to the project location. Pick up Department-furnished materials during normal business hours.

3. WORK METHODS

Replace guard fence, including thrie beam, curb, and transitions, in accordance with Item 540, "Metal Beam Guard Fence," and as shown on the plans or as directed. Work requests are made on a callout basis. Begin physical work within 72 hr. of notification, unless otherwise shown on the plans. Replace end treatments in accordance with Item 544, "Guardrail End Treatments," and as shown on the plans or as directed. Weld in accordance with Item 448, "Structural Field Welding." Repair concrete in accordance with Item 429, "Concrete Structure Repair." Remove guard fence in accordance with Item 542, "Removing Metal Beam Guard Fence." Replace rail and posts removed during the same workday, unless otherwise approved.

- Protect traffic from exposure to unattached rail elements left overnight, as approved.
- Cover or fill postholes at the end of each day.
- Place rail to a smooth line and grade, with posts plumb to the correct height, in accordance with the plans.
- Remove salvageable rail elements in original lengths. Remove fittings from posts and rail elements. Deliver salvageable materials to a designated stockpile site and neatly stack as directed. Reuse salvageable materials in the repair as approved.
- Dispose of debris and damaged components in accordance with all federal, state, and local regulations.

- 3.1. **Repair of Rail Element.** Remove and replace rail elements as directed. Bolt rail elements end to end and lap in the direction of traffic in the lane adjacent to the guard fence. Provide prefabricated curved rail when needed. Field-drill, punch, or use other approved methods to create holes for special details. Tighten nuts. Replace bridge end connection when required, in accordance with Item 540, "Metal Beam Guard Fence."

- 3.2. **Removal and Replacement of Timber or Steel Post.** Replace posts as directed. Dispose of any concrete removed. Drill new post holes as needed. Clean postholes free of loose dirt and debris, and thoroughly compact bottom of hole to the correct elevation for placement of post. Place post to the correct alignment, elevation, and plumb. Backfill with select material by thoroughly compacting material to the density of adjacent undisturbed material. Replace concrete foundations only as directed. Use grout to fill space between riprap and posts when replacing posts.
- 3.3. **Realignment of Posts.** Realign existing posts to a smooth line and grade.
- 3.4. **Repair of Terminal Anchor Post.** Repair the steel anchor post by straightening or welding to the existing post above the concrete foundation.
- 3.5. **Replacing Terminal Anchor Posts.** Remove and replace damaged anchor posts with foundation or install new anchor posts with foundation. Remove anchor and clean existing holes or drill new holes, as approved.
- 3.6. **Removal of Guardrail End Treatment and Replacement with SGT.** Remove damaged guard fence end treatment and replace with complete new SGT.
- 3.7. **Repair of SGT.** Remove damaged SGT components and replace with new components. Salvage and reuse components as approved.
- 3.8. **Repair of Steel Post with Base Plate.** Replace damaged steel posts with base plates. Drill anchor holes and install new bolts or weld new anchor bolts to existing bolts as directed. Field-weld in accordance with Item 448, "Structural Field Welding," or shop-weld in accordance with Item 441, "Steel Structures." Repair damaged galvanized coating in accordance with Section 445.3.5., "Repairs."
- 3.9. **Raise Rail Element.** Raise rail as shown on the plans.
- 3.10. **Repair of Blockouts.** Remove and replace damaged or deteriorated blockouts with new blockouts when shown on the plans or as directed.

4. MEASUREMENT

This Item will be measured as follows:

- 4.1. **Repair of Rail Element (W-Beam, Thrie-Beam, or Thrie-Beam Transition to W-Beam).** By the foot along the face of the rail from center to center of the slotted hole at each end of the rail elements repaired, including the terminal anchor section and the rail with any bolt hole spacing, but excluding the first 2 rail elements of the SGT section.
- 4.2. **Removal and Replacement of Timber or Steel Posts without Concrete Foundation.** By each post replaced.
- 4.3. **Removal and Replacement of Timber or Steel Posts with Concrete Foundation.** By each post replaced.
- 4.4. **Realignment of Posts.** By each post realigned.
- 4.5. **Repair of Terminal Anchor Post.** By each post repaired.
- 4.6. **Replacement of Terminal Anchor Posts.** By each post replaced.
- 4.7. **Removal of Guardrail End Treatment and Replacement with SGT.** By each SGT.
- 4.8. **Replacement of SGT Impact Head.** By each head.
- 4.9. **Replacement of SGT Rail.** By the foot from center to center of posts, 2 rails.

- 4.10. **Replacement of SGT Post.** By each post replaced, includes metal sleeves.
- 4.11. **Remove and Replace Blockouts.** By each blockout replaced.
- 4.12. **Repair of Steel Post with Base Plate.** By each post repaired. Includes top or side mount posts.
- 4.13. **Remove and Reset SGT Impact Head.** By each head reset.
- 4.14. **Replace SGT Object Marker.** By each marker replaced, as directed, including the removal and disposal of the existing rubber bumpers.
- 4.15. **Replace SGT Cable Anchor.** By each cable anchor replaced.
- 4.16. **Replace SGT Cable Assembly.** By each cable assembly replaced.
- 4.17. **Replace SGT Strut.** By each strut replaced.
- 4.18. **Raise Rail.** By the foot along the face of the rail from center to center of the slotted hole at each end of the rail element raised.

5. PAYMENT

The work performed and the materials furnished in accordance with this Item and measured as provided under "Measurement" will be paid at the unit price bid for: "Repair Rail Element of the type specified," "Raise Rail of the type specified," "Remove Post of the type specified," "Replace Post of the type specified," "Repair Post of the type specified," "Realign Posts of the type specified," "Remove Guardrail End Treatment and Replace with SGT," "Replace SGT Impact Head," "Remove and Reset SGT Impact Head," "Remove and Replace Blockouts," "Replace SGT Object Marker," "Replace SGT Cable Anchor," "Replace SGT Cable Assembly," and "Replace SGT Strut."

This price is full compensation for repairing rail and furnishing equipment, materials, labor, tools, and incidentals. Realignment of existing rail without removing will not be paid for directly but considered subsidiary to realigning posts. Replacement of concrete riprap around posts, removal and replacement of curbs, and bridge end connection will not be paid for directly but considered subsidiary to the various bid items. Replacement of SGT components not mentioned above will not be paid for directly but considered subsidiary to the various bid items. Concrete repair will be paid for in accordance with pertinent Items. Payment for repair of steel posts with base plate includes work performed above the concrete foundation. Any rail removed and replaced to remove/replace posts will not be paid for directly but considered subsidiary to various bid items.

Coring new holes and furnishing new bolts and epoxy for the repair or replacement of posts with base plate will be considered subsidiary to various bid items.

Item 771

Repair Cable Barrier System



1. DESCRIPTION

Repair cable barrier system and cable barrier terminal sections of the type shown.

2. MATERIALS

Furnish new materials in accordance with Item 543, "Cable Barrier System."

Pick up materials furnished by the Department at the locations shown on the plans.

Salvage materials as directed. Accept ownership of unsalvageable materials and dispose of in accordance with federal, state, and local regulations.

3. WORK METHODS

Remove and replace cable barrier system components and cable barrier terminal sections in accordance with the details shown on the plans and manufacturer's recommendations. Place posts into steel sleeves in a concrete foundation, unless otherwise shown on the plans.

Begin physical repair for contracts with callout work within 72 hr. of notification, unless otherwise shown on the plans. Repair damaged components such as terminal anchor sections, concrete foundations, cables, posts, and pavement, as necessary to ensure the final installation functions as designed. Replace non-repairable cable. Replace delineators and object markers at terminal ends as needed. Sweep and clean area around cable barrier system.

Provide a tension meter and use it after repair is complete to verify cables in repaired area are properly tensioned. Re-tension the cable barrier system to within manufacturer recommended range as needed. Check cables for proper tensioning when requested and re-tension to within manufacturer recommended range as needed.

4. MEASUREMENT

This Item will be measured as follows:

- 4.1. **Replace Posts.** By each post replaced.
- 4.2. **Cable Splice/Turnbuckle.** By each cable splice made.
- 4.3. **Repair Concrete Foundation.** By each foundation repaired.
- 4.4. **Repair or Replace Cable Barrier Terminal Section.** By each section repaired or replaced.
- 4.5. **Replace Cable.** By the foot of damaged cable.
- 4.6. **Check and Re-Tension Cables.** By each run checked and re-tensioned. A run is defined as a section of cable barrier system beginning and ending with a terminal section.

5. PAYMENT

The work performed and materials furnished in accordance with this item and measured as provided under "Measurement" will be paid for at the unit price bid for "Replace Posts," "Cable Splice/Turnbuckle," "Repair Concrete Foundation," "Repair or Replace Cable Barrier Terminal Section," and "Replace Cable," and "Check and Re-Tension Cables," all of the test level specified (TL-3, TL-4, etc.). This price is full compensation for repairing cable barrier system components and cable barrier terminal sections; checking and re-tensioning of a run, furnishing materials; salvage, removal, and disposal; concrete; delineator and object marker replacement; and equipment, labor, tools, and incidentals.

Item 772

Post and Cable Fence



1. DESCRIPTION

Install, repair, or remove post and cable fence.

2. MATERIALS

Furnish materials as follows, unless otherwise shown on the plans.

- 2.1. **Posts.** Furnish timber posts meeting DMS-7200, "Timber Posts and Blocks for Metal Beam Guard Fence."
- 2.2. **Cable.** Furnish wire cable meeting ASTM A475 and the following requirements:
- 3/8 in. nominal strand diameter,
 - 7-wire strand, common grade,
 - minimum breaking strength of 4,000 lb., and
 - 0.30 oz. per square foot minimum weight of zinc coating.
- 2.3. **Fittings and Anchors.** Furnish fittings and anchors galvanized in accordance with ASTM A153.
- 2.4. **Concrete.** Furnish concrete meeting Item 421, "Hydraulic Cement Concrete," of the class shown on the plans.
- 2.5. **Reflectors.** Furnish reflectors as shown on the plans.
- 2.6. **Backfill.** Furnish backfill material as approved.
- 2.7. **Gate.** Furnish gates as shown on the plans.

3. WORK METHODS

Install, repair, or remove post and cable fence, including reflectors and related items as shown on the plans.

- 3.1. **Removal.** Remove concrete anchors, posts, and cable. Backfill and thoroughly compact post and anchor holes. Accept ownership of removed materials, unless otherwise shown on the plans. Dispose of removed materials in accordance with federal, state, and local regulations.
- 3.2. **Installation.** Place new anchors, posts, and cable as shown on the plans. Set posts on firm foundation and plumb to the required lines and grades. Thoroughly compact backfill in 4-in. layers. Space pull posts as shown on the plans. Lengthen or shorten one pull post space per continuous section if necessary to accommodate site conditions. Cover or fill open holes at the end of each workday.
- Maintain current pull post spacing of existing installations if approved. Straighten undamaged posts that are more than 1 in. out of plumb. Stretch cable to remove sag between posts. One cable splice will be allowed between posts, adjacent to the post, but no more than 2 splices in any 100 ft. of cable. Painting is not required, unless otherwise shown on the plans.
- 3.3. **Repair.** Plumb and realign post in a vertical and horizontal position. Stretch cable to remove sag between posts. One cable splice will be allowed between posts, adjacent to the post, but no more than 2 splices in

any 100 ft. of cable. Removal and replacement of posts, anchors, or cable will be paid with the appropriate bid item.

4. MEASUREMENT

This Item will be measured as follows:

- 4.1. **Post and Cable Fence Removal.** By the foot from center to center of pull posts.
- 4.2. **Concrete Anchor Removal.** By each anchor removed.
- 4.3. **New Installation of Post and Cable Fence.** By the foot of fence from center to center of pull posts for each continuous section installed.
- 4.4. **New Concrete Anchor.** By each anchor installed.
- 4.5. **Removal and Replacement of Posts.** By each post removed and replaced.
- 4.6. **Removal and Replacement of Concrete Anchors.** By each anchor removed and replaced.
- 4.7. **Removal and Replacement of Cable.** By the foot of cable removed and replaced.
- 4.8. **New Installation of Post and Cable Fence (Gate).** By each gate installed.
- 4.9. **Repair.** By the foot of fence from center to center of pull posts for each repair.

5. PAYMENT

The work performed and the materials furnished in accordance with this Item and measured as provided under "Measurement" will be paid for at the unit price bid for "Post and Cable Fence (Removal)," "Post and Cable Fence (Remove Concrete Anchor)," "Post and Cable Fence (New Installation)," "Post and Cable Fence (New Concrete Anchor)," "Post and Cable Fence (Remove and Replace Posts)," "Post and Cable Fence (Remove and Replace Concrete Anchors)," or "Post and Cable Fence (Remove and Replace Cable)," "Post and Cable Fence (Gate) (New Installation)," or "Post and Cable Fence (Repair)." This price is full compensation for cable splices, straightening posts, realignments of posts, tightening cable, backfilling posts and anchor holes, installation of reflectors, bollards, foundations, backfilling, gate and hardware, paint, materials, equipment, labor, tools, and incidentals.

Item 774

Attenuator Repair



1. DESCRIPTION

Repair or replace damaged attenuators or crash cushions.

2. MATERIALS

Furnish materials in accordance with details shown on the plans.

3. WORK METHODS

Repair or replace attenuators as approved. Begin physical repair for Contracts with callout work within 72 hr. of notification, unless otherwise shown on the plans. Repair damaged components, such as foundation, concrete, anchors, and pavement, as necessary to ensure the final installation functions as designed. Sweep and clean area around attenuator. Dispose of debris and damaged components in accordance with federal, state, and local regulations. Weld in accordance with Item 448, "Structural Field Welding," as directed or approved. Salvage materials as directed.

- 3.1. **Removal and Replacement.** Remove existing attenuator and replace with a system shown on the plans or as directed.
- 3.2. **Repair.** Remove and replace damaged elements of attenuators and repair to meet the installation requirements of the system shown on the plans and the specifications that pertain to that appropriate system.

4. MEASUREMENT

- 4.1. **Removal and Replacement.** When replacing a complete unit, measurement will be by each unit.
- 4.2. **Repair.** Repair will be measured by the each for the component specified or by the foot.

5. PAYMENT

The work performed and the materials furnished in accordance with this Item and measured as provided under "Measurement" will be paid for at the unit price bid for "Remove and Replace" or "Repair" of the type or component specified. This price is full compensation for repairing or replacing attenuators; furnishing materials; salvage and disposal; and equipment, labor, tools, and incidentals.

Item 776

Metal Rail Repair



1. DESCRIPTION

Repair metal traffic or pedestrian rail. Replace metal traffic or pedestrian rail if beyond repair as determined by the Engineer.

2. MATERIALS

Furnish materials in accordance with Item 450, "Railing," and details shown on the plans.

3. WORK METHODS

Remove damaged steel or aluminum rail and repair to match the original or details shown on the plans. Replace steel or aluminum rail to match the original or details shown on the plans if the damaged rail is beyond repair as determined by the Engineer. Begin physical repair for Contracts with callout work within 72 hr. of notification, unless otherwise shown on the plans. Repair damaged components, anchors, etc., as necessary to ensure the final installation functions as originally constructed. Drill anchor holes and install new bolts or weld new anchor bolts to existing bolts as directed. Weld in accordance with Item 441, "Steel Structures," or Item 448, "Structural Field Welding." Repair damaged galvanized coating in accordance with Section 445.3.5., "Repairs." Paint repaired areas of painted rail to match existing color, in accordance with Item 446, "Field Cleaning and Painting Steel." Repair railing removed for repair during the same workday unless otherwise approved. Deliver salvageable materials to a designated stockpile site and dispose of debris and damaged components in accordance with federal, state, and local regulations.

4. MEASUREMENT

Rail repair will be measured by the foot between centers of the first undamaged post on each side of the repair or to the end of the rail. Repairing metal post with base plate will be measured by each post repaired. Rail replacement will be measured by the foot between centers of the first undamaged post on each side of the replacement or to the end of the rail.

5. PAYMENT

The work performed and materials furnished in accordance with this Item and measured as provided under "Measurement" will be paid for at the unit price bid for "Repair" of the type specified, "Repair Metal Post with Base Plate" of the type specified, and "Replacement" of the type specified. This price is full compensation for removing and repairing rail; salvage and disposal; and materials, tools, equipment, labor, and incidentals. Concrete repair will be paid for in accordance with Item 429, "Concrete Structure Repair."

Item 778

Concrete Rail Repair



1. DESCRIPTION

Repair or replace damaged concrete bridge rail as shown on the plans and as directed.

2. MATERIALS

Provide materials conforming to the pertinent requirements of the following Items except as shown on the plans:

- Item 429, "Concrete Structure Repair,"
- Item 450, "Railing," and
- Item 776, "Metal Rail Repair."

Submit information on pre-packaged repair materials, epoxy anchorage systems, and concrete mix design a minimum of 10 days before beginning work.

3. EQUIPMENT

Provide equipment in accordance with Item 429, "Concrete Structure Repair."

4. WORK METHODS

Obtain approval for all materials and work methods a minimum of 10 days before beginning work.

Repair or replace damaged concrete rail as shown on the plans. Perform the work in accordance with Item 429, "Concrete Structure Repair," and Item 450, "Railing," as directed.

Contain concrete during removal from falling onto lower roadway or into waterway.

Remove and replace full height of rail if damage exceeds one half of the rail height, except as shown on the plans and as directed.

Remove existing metal rail components and attachments and salvage for reuse when undamaged or repairable.

Saw-cut perimeter of concrete repair region 1/2 in. deep. Remove concrete to limits shown on the plans and as directed to remove spalled and delaminated areas. Increase repair length to remove the cracked concrete as directed where cracks associated with impact damage remain outside the specified repair area.

Repair rail supporting structure (i.e., bridge deck, wingwall, etc.) when damaged in accordance with additional Items of work as shown on the plans and as directed. Include new rail anchorage reinforcing steel in supporting structure as required.

Drill into undamaged base concrete and add epoxy anchored reinforcing steel to restore severed or damaged rail anchorage reinforcing steel. Provide epoxy anchorage system rated to obtain yield strength of bar being anchored based on the product literature for the epoxy and steel anchor being used. Use 60 ksi reinforcing steel. Clean and extend existing reinforcing steel and replace any damaged steel or add additional steel as shown on the plans. Restore shape of rail to match original.

Provide surface finish to match original.

Reinstall metal rail components and attachments where previously present.

Salvage and reinstall metal components of expansion joint and joint seal to match existing conditions when repair and replacement occurs at an expansion joint. This work is subsidiary to this Item.

5. MEASUREMENT

This Item will be measured by the foot of rail repaired or replaced and by the each rail post repaired or replaced.

6. PAYMENT

The work performed and materials furnished in accordance with this Item and measured as provided under "Measurement" will be paid for at the unit price bid for "Concrete Rail Repair," "Concrete Rail Replacement," "Concrete Post Repair," and "Concrete Post Replacement" of the type identified. This price is full compensation for removing and reinstalling metal rail components; for breaking back and restoring concrete rail; for furnishing and placing all materials; for salvaging and reinstalling existing expansion joints; and for all labor, tools, equipment, and incidentals necessary to complete the work.

Item 780

Concrete Crack Repair



1. DESCRIPTION

Repair cracks in concrete members by epoxy injection, gravity filling, routing and sealing, or surface sealing.

2. MATERIALS

Provide materials in accordance with the Department's *Concrete Repair Manual*. Select a pre-approved material meeting the requirements of the applicable DMS when available.

3. WORK METHODS

Follow the procedures outlined in the Department's *Concrete Repair Manual*. Submit alternate procedures to the Engineer for approval before proceeding with repair work.

The manual includes the following categories of concrete crack repair:

- Pressure-Injected Epoxy,
- Gravity-Fed Sealant,
- Routing and Sealing, and
- Surface Sealing.

4. MEASUREMENT

This Item will be measured by the foot of exterior crack length, injected gallon, square footage for flood coats, or lump sum.

5. PAYMENT

The work performed and the materials furnished in accordance with this Item and measured as provided under "Measurement" will be paid for at the unit price bid for "Concrete Crack Repair" of the type specified. This price is full compensation for furnishing and installing all repair materials, equipment, labor, and incidentals.

Item 784

Steel Member Repair



1. DESCRIPTION

Repair steel bridge members such as beams, girders, diaphragms, trusses, and piling.

2. MATERIALS

Furnish materials in accordance with the following:

- epoxy in accordance with DMS-6100, "Epoxies and Adhesives,"
- grout in accordance with Item 421, "Hydraulic Cement Concrete,"
- replacement steel in accordance with Item 442, "Metal for Structures," and
- paint in accordance with Item 446, "Field Cleaning and Painting Steel."

3. EQUIPMENT

Provide equipment, including restraining equipment when required, capable of indicating the amount of force applied.

4. GENERAL

Repair or replace steel bridge members in accordance with the plans. Submit a plan that includes the repair method, application of heat and restraint, material, temporary bracing or shoring, and equipment. Obtain approval of the plan before beginning work. Field-weld in accordance with Item 448, "Structural Field Welding." Perform heat straightening using welding personnel certified for unlimited thickness and all positions in accordance with Item 448, "Structural Field Welding." Perform shop fabrication in accordance with Item 441, "Steel Structures."

Only welders certified or working directly under the supervision of a welder certified in accordance with Item 448, "Structural Field Welding," may handle torches when applying heat to steel members.

Use drills to place holes in steel members. Ensure torches are not used to place holes unless authorized or permitted on the plans.

Do not fill holes with weld metal.

- 4.1. **Heat Straightening.** Return all distorted members to their original section, tilt, and straightness by heat straightening. Use approved mechanical devices to restrain the member while applying heat to straighten the distorted metal. Ensure mechanical forces are not used to straighten or bend the metal. Ensure impact loads such as hammer blows are not applied. Repair cracks as shown on the plans before straightening. Repair minor dents, nicks, and gouges by grinding the defect to an acceptable contour and appearance with all corners rounded to a 1/16-in. radius. Grind so the finished grinding marks run in the direction of the applied stresses. Straighten steel members to the tolerances of Table 1.

Table 1
Straightening Tolerances

Greatest Cross-Section Dimension	Maximum Cross-Section Displacement	Maximum Departure from Straightness (per foot of length)
Over 36"	0.5"	0.05"
12–36"	0.375"	0.0375"
Under 12"	0.25"	0.025"

- 4.1.1. **Restraining Force.** Apply and lock-off load before applying heat when jacks are used. Limit restraining forces applied before heating to the values shown on the plans or as approved. Ensure the member is not loaded in a manner that causes material to yield without the application of heat.
- 4.1.2. **Heating process.** Heat steel and maintain temperature above 700°F while straightening, but no greater than 1,200°F for typical steel grades, and 1,100°F for Q&T, HPS 70W, or 100/100W grade steel.
- Use only multi-flame heating tips unless approved otherwise, and proportion tip size to the thickness of the material. Manipulate heating torches to guard against overheating. When vee or rectangular heat patterns are used, mark the patterns on the steel before heating. Bring steel within the planned temperature as rapidly as possible without overheating. Guard against buckling when heating relatively thin, wide plates. Closely monitor temperatures with temperature-sensitive crayons, pyrometers, or infrared non-contact thermometers. Measure the temperature 5–10 sec. after the heating flame leaves the area to be tested.
- 4.1.3. **Cooling.** Use dry compressed air for cooling after the steel has cooled to below 600°F. Ensure the steel is not cooled with water or mist. Allow the steel to cool below 250°F before applying another set of heating patterns.
- 4.2. **Section Replacement.** Replace sections of steel members as shown on the plans or as approved. Use steel backing plates in accordance with AASHTO/AWS D1.5 when placing complete joint penetration groove welds from one side only. Remove backing plates after completing welding operations.
- 4.3. **Bearing Establishment.** Repair areas of incomplete bearing between the slab and the beam by epoxy injection in accordance with Item 780, "Concrete Crack Repair," or placement of a grout mixture in accordance with Item 421, "Hydraulic Cement Concrete," as directed.
- 4.4. **Painting.** Complete repairs before painting. Paint repaired area only, unless otherwise shown on the plans, in accordance with Item 446, "Field Cleaning and Painting Steel." Match the color of the existing appearance coating.

5. MEASUREMENT

This Item will be measured by each repaired member or lump sum for the entire bridge. A member is defined as one of the following individual components:

- steel beam or girder over the length of one span, unless otherwise shown on the plans;
- diaphragm and its connecting hardware between adjacent steel beams;
- truss vertical;
- truss diagonal;
- truss sway brace;
- piling; or
- other elements shown on the plans.

6. PAYMENT

The work performed and materials furnished in accordance with this Item and measured as provided under "Measurement" will be paid for at the unit price bid for "Steel Member Repair" of the component specified

when measured by each member, or for "Steel Member Repair" when measured by lump sum. This price is full compensation for repairing steel bridge members and steel, grout, epoxy, materials, equipment, labor, tools, and incidentals.

No additional payment will be made if the Contractor elects to replace a member indicated to be repaired.

Item 785

Bridge Joint Repair or Replacement



1. DESCRIPTION

Repair or replace damaged bridge joint as shown on the plans.

2. MATERIALS

Provide materials conforming to the pertinent requirements of the following Items except as shown on the plans:

- Item 429, "Concrete Structure Repair,"
- Item 449, "Anchor Bolts,"
- Item 454, "Bridge Expansion Joints," and
- DMS-6100, "Epoxies and Adhesives."

Submit information on pre-packaged repair materials and concrete mix design a minimum of 10 days before beginning work.

3. EQUIPMENT

Provide equipment in accordance with Item 429, "Concrete Structure Repair," and Item 448, "Structural Field Welding."

4. WORK METHODS

Obtain approval for all materials and work methods before beginning work.

Repair damaged bridge joints as shown on the plans. Perform the work in accordance with Item 429, "Concrete Structure Repair," Item 438, "Cleaning and Sealing Joints," Item 448, "Structural Field Welding," and Item 454, "Bridge Expansion Joints," as directed. Provide certified welder when shown on the plans.

Remove concrete and steel sections to limits shown on the plans and as approved when damage extends past specified regions. Repair concrete and steel members damaged by the Contractor beyond limits shown at no additional cost. Contain concrete during removal from falling onto lower roadway or into waterway. Remove existing joint and seal. Ensure prestressed concrete deck panel is not damaged during concrete removal. Clean and extend existing reinforcing steel and replace any damaged steel or add additional steel as shown on the plans.

Examine existing steel joint, finger plate, armor plate, or sliding plate to determine if the items are salvageable. Reinstall anchor bolts, anchor studs, and other steel attachments if loose and in accordance with the plans.

Install replacement joint system as shown on the plans. Set joint opening as shown on the plans and as directed. Restore concrete under and around joint flush with top of riding surface. Cure repaired concrete a minimum of 4 days, unless directed otherwise.

Prepare and seal joint opening. Match existing joint seal type unless shown otherwise. Splice new joint seal to existing joint seal when required in accordance with manufacturer's recommended practices to obtain adequate bond between existing seal and new seal.

5. MEASUREMENT

This Item will be measured by the foot of joint repaired, per side of joint opening, and by the foot of joint replaced.

6. PAYMENT

The work performed and materials furnished in accordance with this Item and measured as provided under "Measurement" will be paid for at the unit price bid for "Bridge Joint Repair" and "Bridge Joint Replacement" of the type identified. This price is full compensation for removing existing joint and seal; breaking back and repairing concrete damaged for joint removal and replacement; removing and replacing additional concrete as shown on the plans; furnishing and placing all materials, cleaning and sealing the joints, disposal of all materials removed, additional sealant required to extend into concrete rail or curb, additional material that may be required due to existing asphalt and concrete removal being more than estimate on the plans; and for all labor, tools, equipment, and incidentals necessary to complete the work.

Item 786

Carbon Fiber Reinforced Polymer



1. DESCRIPTION

Furnish and install a carbon fiber reinforced polymer (CFRP) system for protecting, or strengthening concrete members.

2. MATERIALS

Provide unidirectional high-strength carbon fiber fabric, fully saturated with compatible epoxy resin per manufacturer's recommendations, to form a CFRP system unless otherwise shown on the plans. Use carbon fibers in the CFRP system that conforms to the minimum requirements of Table 1 and pre-approved for use unless otherwise shown on the plans. Pre-approved CFRP systems are listed on the website, maintained by the Department, or shown on the plans.

Table 1
CFRP Carbon Fiber Property Requirements

Property	Specification Requirement
Tensile Strength ¹	550,000 psi
Tensile Modulus ¹	33,000,000 psi
Ultimate Elongation ¹	1.50%

1. Verified by ASTM D3039 test procedure

Provide appearance coating recommended by CFRP system manufacturer to protect the CFRP from ultraviolet radiation. Match color of protective appearance coating to adjacent concrete.

Submit a schedule of repair materials to be used including detailed application instructions. Provide manufacturer's product data sheets that include: mechanical, physical, and chemical properties, for the proposed primer, putty, resin, saturant, carbon fiber, and protective appearance coating. Provide manufacturer's Material Safety Data Sheets (MSDS) for all materials to be used on site and certification the materials conform to local, state, and federal environmental and worker's safety laws and regulations.

Provide all CFRP components (excluding fabric) in original factory-sealed, unopened packaging clearly marked with the manufacturer's name, product identification (including brand, system identification number, and batch number), and expiration date or shelf life. Store and handle the products in accordance with the manufacturer's instructions. Ensure out of date components are not used.

3. WORK METHODS

Obtain approval for all materials, qualifications, and methods of application a minimum of 10 days before beginning application. Provide a technical representative from a CFRP manufacturer for concrete member strengthening to provide on-site project support, to verify adequacy of surface preparation, and during the initial installation of the strengthening materials.

- 3.1. **Qualifications.** Provide documentation from the CFRP manufacturer showing project personnel have completed training on the CFRP system selected. Ensure trained personnel remain at the worksite at all times to install and direct the CFRP field installation work. Provide documentation for concrete member strengthening work to demonstrate previous CFRP field installation, including successful completion of at least 3 CFRP field installation projects similar in scope and magnitude to the work. Additionally, the Engineer may request the presence of the manufacturer's representative for additional training if work personnel are

not adequately following manufacturer's installation directions. CFRP work will be delayed until personnel are trained and have demonstrated proper installation on approved mock location at the Contractor's expense.

- 3.2. **Working Drawings.** Working drawings are not required for CFRP application to confine or protect concrete members, unless otherwise shown on the plans. Provide working drawings and calculations signed and sealed by a licensed professional engineer for concrete member strengthening. Include in working drawings: repair locations; relevant dimensions of the system; details of the number, thickness, and orientation of carbon fiber layers; locations of splices and corresponding lap lengths; number, size, and location of CFRP anchors; and construction procedures specifying the individual steps in the installation process. Identify the environmental and substrate conditions that may affect the application and curing of the CFRP system. Calculations must show the proposed system provides the required strengthening as designated on the plans.
- 3.3. **Concrete Structure Repair.** Perform concrete structure repair in accordance with Item 429, "Concrete Structure Repair" as shown on the plans. Allow enough time for concrete repair material to cure in accordance with CFRP manufacturer's specifications before placing CFRP. Repairing surface defects to ensure required contact surface condition is not considered concrete structure repair and is required work for this Item.
- 3.4. **Surface Preparation.** Prepare concrete substrate surfaces to promote continuous intimate contact between the CFRP and the concrete by providing a clean, smooth, and flat or convex surface. Grind away all irregularities, unevenness, and sharp protrusions to provide less than 1/32-in. surface profile deviation. Fill all voids or depressions of diameters larger than 1/2 in. or depths greater than 1/8 in. with approved material. Provide surface roughness requirements for strengthening as detailed in working drawings. Round or chamfer all inside and outside corners and sharp edges to a minimum radius of 1/2 in. Remove all laitance, dust, dirt, oil, foreign particles, disintegrated materials, and any other matter that could interfere with the bond of the CFRP to the concrete using abrasive blasting.
- Drill holes in concrete using a rotary impact drill when CFRP anchors are shown on the plans. Ensure existing reinforcing steel is not cut when drilling holes. Thoroughly clean holes by using a wire hole-brush and oil-free compressed air to remove all drill powder from interior surfaces of hole.
- 3.5. **Installation.** Monitor environmental conditions before and during installation of the CFRP system to ensure conformity with the contract requirements and manufacturer's recommendations. Ensure CFRP components are not installed if the substrate surface is moist or wet, or if ambient or concrete surface temperatures are outside the 50°F to 95°F temperature range. Apply CFRP only when relative humidity is below 85% and the surface temperature is at least 5°F above the dew point temperature.
- Apply system using the wet lay-up method unless otherwise approved. Install the CFRP system in accordance with contract requirements, working drawings, and the manufacturer's recommendations. Release or roll out entrapped air beneath each layer before the resin sets. Obtain approval before implementing any change to the approved installation procedure.
- Place CFRP anchors between layers of the applied system when shown on the plans.
- 3.6. **Testing.** Perform the following tests after the initial resin has cured at least 24 hours and in accordance with manufacturer's specifications: a visual inspection of the entire CFRP surface, an acoustic tap test of any areas suspected to contain air pockets, and at least 2 direct pull-off tests for each member strengthened in accordance with ASTM D4541 to verify the tensile bond between the concrete and the CFRP system. The Engineer will select areas to perform the direct pull-off test. Perform some or all direct pull-off tests on CFRP test samples prepared at locations of similar substrate near the CFRP installation area at the discretion of the Engineer. Prepare the test samples using identical application procedures at the same time the project CFRP is installed. The required minimum pull-off stress is 200 psi, or failure in the concrete substrate, unless otherwise shown on the plans. Repair the damaged CFRP and concrete at test areas after testing is completed with thickened resin or putty.

- 3.7. **Remediation.** Epoxy-inject behind CFRP layers where small voids and bubbles are located that have a nominal size of 3 in. or less. Analyze defect areas larger than 3 in. and perform repair work as directed, which could include removal and replacing portions or all the applied CFRP. Perform required remediation for pull-off test results failing to meet the required minimum as directed.
- 3.8. **Protective Appearance Coat.** Clean and paint CFRP system in accordance with manufacturer's specifications.

4. MEASUREMENT

This Item will be measured by the square foot of concrete area covered with CFRP system. This is a plans quantity measurement Item. The quantity to be paid is the quantity shown in the proposal, unless modified by Article 9.2., "Plans Quantity Measurement." Additional measurements or calculations will be made if adjustments of quantities are required.

5. PAYMENT

The work performed and materials furnished in accordance with this Item and measured as provided under "Measurement" will be paid for at the unit price bid for "Carbon Fiber Reinforced Polymer Protection," and "Carbon Fiber Reinforced Polymer Strengthening." This price is full compensation for all materials, labor, equipment, pull-off testing (including repair of test sites), manufacturer's supervision, and related work necessary to prepare the surface of the concrete, to install the CFRP system as detailed on the plans and apply the protective appearance coat.

When not shown on the plans as a separate pay item, payment for installing CFRP is subsidiary to the pertinent Items.

Item 788

Concrete Beam Repair



1. DESCRIPTION

Repair damaged beams. Beam damage may include delamination, surface spalling, section loss, and cracking.

2. WORK METHODS

Provide materials and perform work as required in the *Concrete Repair Manual*, as shown on the plans, and in accordance with the pertinent Items as follows:

- Item 429, "Concrete Structure Repair," for repairing unsound, delaminated, or spalled concrete.
- Item 780, "Concrete Crack Repair," for sealing concrete cracks with pressure-injected, gravity-fed, or surface-applied epoxy.
- Item 786, "Carbon Fiber Reinforced Polymer (CFRP)," for confining or strengthening concrete using a CFRP system.

Provide strand and hardware meeting the requirements of Item 424, "Precast Concrete Structural Members (Fabrication)," if strand splicing and re-tensioning is required. Follow work methods as outlined on the plans.

Pre-load the damaged beam before repair work if shown on the plans. Pre-load with a loaded 10-cu. yd. dump truck or other approved method. Keep the pre-load in place until repair concrete has attained a minimum compressive strength of 3,000 psi.

Remove damaged bridge protective assembly as directed. Replace assembly if required in accordance with Item 441, "Steel Structures."

The Engineer will test the quality of the work with hammer blows and any other means necessary to ensure satisfactory performance. Rework or replace defective or debonded work at the Contractor's expense.

Apply supplemental CFRP strengthening as indicated on the plans.

3. MEASUREMENT

This Item will be measured by each beam repaired.

4. PAYMENT

The work performed and materials furnished in accordance with this Item and measured as provided under "Measurement" will be paid for at the unit bid price for "Concrete Beam Repair," "Concrete Beam Repair plus Strand Splicing," "Concrete Beam Repair plus CFRP," and "Concrete Beam Repair plus Strand Splicing and CFRP." This price is full compensation for repair; supplemental exterior confinement or strengthening; and furnishing equipment, labor, materials, tools, and incidentals.

Item 789

Treatment for ASR-Affected Concrete



1. DESCRIPTION

Treat concrete members affected by Alkali Silica Reaction (ASR).

2. MATERIALS

Furnish materials in accordance with this Item.

- 2.1. **Penetrating Concrete Surface Treatment/Primer.** Provide silane meeting the requirements of DMS-8140, "Concrete Surface Treatment (Penetrating)," or primer as shown on the plans.
- 2.2. **Silicone-Based Top Coat.** Provide silicone resin emulsion paint (SREP) meeting the requirements of DMS-8141, "Paint, Silicone Resin for Concrete." Match color of coating with Federal Standard 595C color 35630, concrete gray, unless otherwise shown on the plans.
- 2.3. **Caulk.** Provide a caulk meeting the requirements of DMS-8142 "Paintable Caulk for Concrete and Steel."

3. EQUIPMENT

Provide equipment as listed in Item 427, "Surface Finishes for Concrete," for Abrasive Blasting, Slurry Blasting, and Spraying. Provide equipment suitable for application of the caulk chosen. The Engineer may require demonstration of the equipment's capabilities.

4. CONSTRUCTION

Treat all areas as indicated on the plans or as directed. Apply the treatment in the following order if a carbon wrap is used as part of the ASR mitigation.

- Fill or inject the cracks with epoxy.
- Apply the wraps.
- Apply the primer.

- 4.1. **Surface Preparation.** Prepare all surfaces to be treated to "Blast Finish" in accordance with Item 427, "Surface Finishes for Concrete." Use only abrasive blasting or another approved method to remove all laitance, paint, and other contaminants that may retard or prevent the absorption of the surface treatment material into the concrete or compromise the bond of the crack-sealing caulk. Ensure high-pressure water blasting is not used to clean the surfaces. Use water-injected abrasive blasting (less than 1 gpm of water) to clean the surfaces if dust control measures are required. Brush off remaining residue before applying surface treatment.
- 4.2. **Application of Penetrating Sealer/Primer.** Apply the penetrating surface treatment in accordance with Item 428, "Penetrating Concrete Surface Treatment."
- Work the surface treatment into cracks for maximum penetration. Follow the manufacturer's recommended application rate if it is higher than specified in Item 428, "Penetrating Concrete Surface Treatment."
- 4.3. **Crack Sealing.** Seal cracks no earlier than 2 days after application of the surface treatment. Seal all cracks wider than 0.005 in. (0.15 mm) with caulk. Seal cracks when the concrete surface and the ambient air temperature are between 40°F and 105°F. Place a small bead of caulk in a designated crack. Use a trowel,

spatula, or similar device to effectively work the caulk into the crack and provide a smooth profile to the bead of caulk. Ensure the caulk does not completely fill the crack, but completely covers the crack opening. Remove any caulk remaining on the surface of the concrete using the trowel or spatula before the caulk has set up.

- 4.4. **Application of Top Coat.** Apply the SREP top coat after the caulk has cured according to the caulk manufacturer's recommendations. Provide a smooth, uniform coating using a roller, brush, or airless sprayer. Back roll spray applications. Apply a first coat with a minimum wet film thickness (WFT) of 4 mils. Apply a second coat at least 24 hours after the first coat with a minimum WFT of 4 mils.

5. MEASUREMENT

This Item will be measured by the square foot of surface area treated. This is a plans quantity measurement Item. The quantity to be paid is the quantity shown in the proposal unless modified by Article 9.2., "Plans Quantity Measurement." Additional measurements or calculations will be made if adjustments of quantities are required.

6. PAYMENT

The work performed and materials furnished in accordance with this Item and measured as provided under "Measurement" will be paid for at the unit price bid for "Treatment for ASR-Affected Structures." This price is full compensation for excavation required on the plans; surface preparation, application of sealer or primer and caulk, and painting as specified on the plans; and for all labor, equipment, tools, and incidentals. Carbon fiber reinforced polymer wraps and associated epoxy work will be paid for in other Items.

