

DISCLAIMER: The use of this standard is governed by the "Texas Engineering Practice Act". No warranty of any kind is made by TxDOT for any purpose whatsoever. TxDOT assumes no responsibility for the conversion of this standard to other formats or for incorrect results or damages resulting from its use.

DATE: FILE:

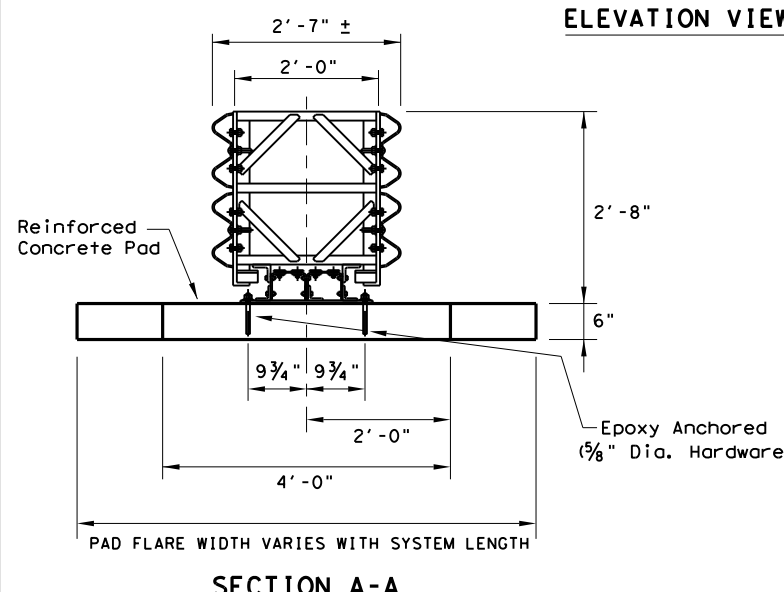
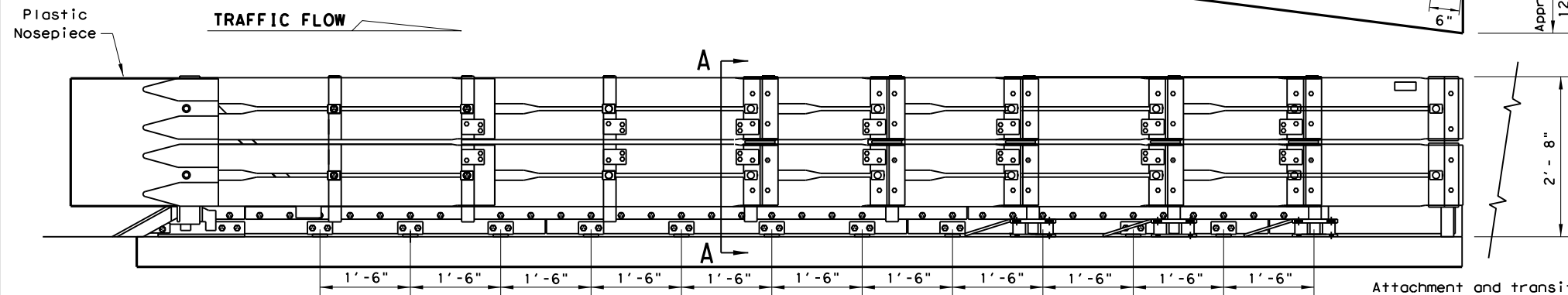
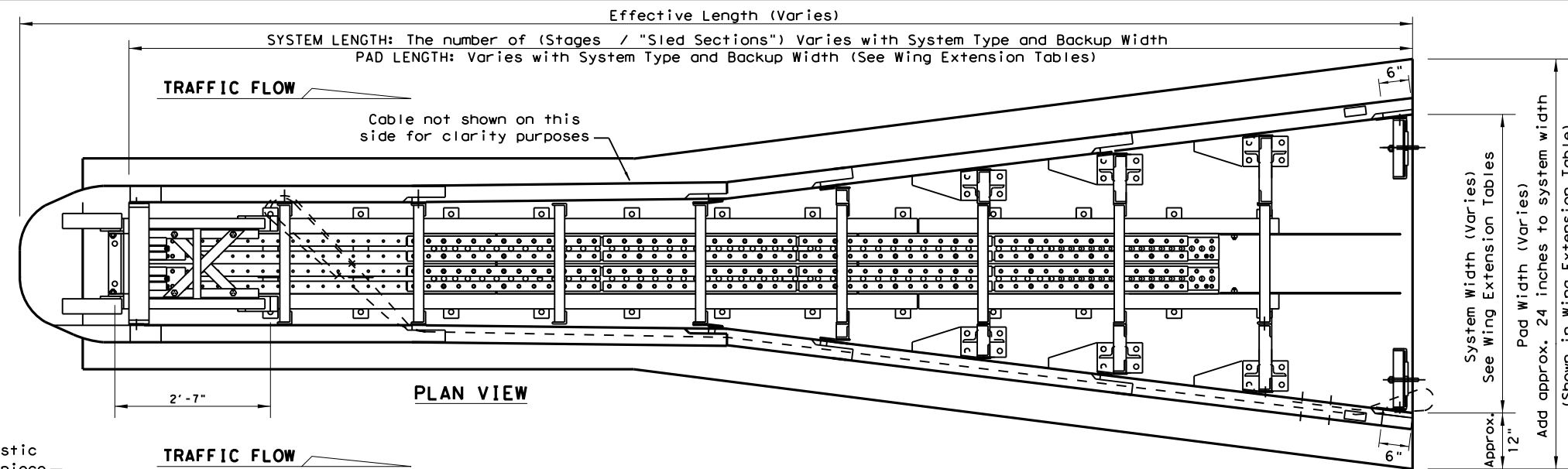

TYPE (WIDE)	TEST LEVEL
FASTRACC (4 Stage System)	70
TRACC (3 Stage System)	TL-3
SHORTTRACC (2 Stage System)	TL-2

NOTE: The Stage System refers to number of replaceable "sled sections" that could be replaced independently.

Wide-FASTRACC WING EXTENSIONS				
NUMBER OF WING EXTENSIONS	WIDTH	SYSTEM LENGTH	EFFECTIVE LENGTH	Wide-FASTRACC EXTENSION PART NUMBER (LEFT# / RIGHT#)
0 (BASE UNIT)	71"	25'-11"	27'-11"	
1	78"	28'-3"	30'-3"	33940
2	85"	30'-7"	32'-7"	33941 / 33942
3	92"	32'-11"	34'-11"	33943 / 33944
4	99"	35'-2"	37'-2"	33945 / 33946
5	106"	37'-6"	39'-6"	33947 / 33948
6	113"	39'-10"	41'-10"	33949 / 33950
7	120"	42'-2"	44'-2"	33951 / 33952
8	127"	44'-5"	46'-5"	33953 / 33954
9	134"	46'-9"	48'-9"	33955 / 33956
10	141"	49'-1"	51'-1"	33957 / 33958
10+				CONSULT TRINITY SALES PERSON

Wide-TRACC WING EXTENSIONS				
NUMBER OF WING EXTENSIONS	WIDTH	SYSTEM LENGTH	EFFECTIVE LENGTH	Wide-TRACC EXTENSION PART NUMBER (LEFT# / RIGHT#)
0 (BASE UNIT)	58"	21'	23'	
1	65"	23'-4"	25'-4"	33940
2	72"	25'-8"	27'-8"	33941 / 33942
3	79"	28'	30'	33943 / 33944
4	86"	30'-4"	32'-4"	33945 / 33946
5	92"	32'-8"	34'-8"	33947 / 33948
6	99"	35'	37'	33949 / 33950
7	106"	37'-4"	39'-4"	33951 / 33952
8	113"	39'-8"	41'-8"	33953 / 33954
9	120"	42'	44'	33955 / 33956
10	127"	44'-4"	46'-4"	33957 / 33958
10+				CONSULT TRINITY SALES PERSON

Wide-SHORTTRACC WING EXTENSIONS				
NUMBER OF WING EXTENSIONS	WIDTH	SYSTEM LENGTH	EFFECTIVE LENGTH	Wide-SHORTTRACC EXTENSION PART NUMBER (LEFT# / RIGHT#)
0 (BASE UNIT)	39"	15'	17'	
1	46"	17'-4"	19'-4"	33940
2	53"	18'-9"	20'-9"	33941 / 33942
3	60"	21'-1"	23'-1"	33943 / 33944
4	66"	23'-5"	25'-5"	33945 / 33946
5	73"	25'-8"	27'-8"	33947 / 33948
6	80"	28'-1"	30'-1"	33949 / 33950
7	87"	30'-4"	32'-4"	33951 / 33952
8	94"	32'-7"	34'-7"	33953 / 33954
9	101"	34'-11"	36'-11"	33955 / 33956
10	108"	37'-3"	39'-3"	33957 / 33958
10+				CONSULT TRINITY SALES PERSON

Attachment and transitions to other shapes, barriers railings and bi-directional traffic flows are available. (See manufacturer's product manual).

BACKUP SUPPORT OPTIONS	
SQUARE CONCRETE BACKUP	
CONCRETE BARRIER (CTB) BACKUP	
SINGLE SLOPE CONCRETE BARRIER (SSCB)	
GUARDRAIL BACKUP (BASE-PLATED POST)	
GUARDRAIL BACKUP (DRIVEN POST)	
TRANSITION OPTIONS	
VERTICAL WALL	
MODIFIED (CTB) TO VERTICAL WALL	
CONCRETE BARRIER (CTB)	
GUARDRAIL (W-BEAM)	
GUARDRAIL (THRIE-BEAM)	

FOR BI-DIRECTIONAL TRANSITION PANEL DETAILS (SEE MANUFACTURER'S PRODUCT MANUAL).
 BACKUP AND TRANSITION TYPES ARE SHOWN ELSEWHERE ON THE PLANS, (I.E. ATTENUATOR LOCATION DETAILS OR IN THE GENERAL NOTES).

FOUNDATION OPTIONS	
6" REINFORCED CONCRETE	
8" UNREINFORCED CONCRETE	
3" MIN. ASPHALT OVER 3" MIN. CONCRETE	
6" ASPHALT OVER 6" COMPACT SUBBASE	
8" MINIMUM ASPHALT	

FOR STEEL PLACEMENT IN CONCRETE FOUNDATIONS, (SEE MANUFACTURER'S PRODUCT MANUAL).

- ### GENERAL NOTES
- For specific information regarding installation and technical guidance of the system, contact: Trinity Highway at 1(888)323-6374, 2525 N. Stemmons Freeway - Dallas, TX 75207
 - Contact the company for: Custom widths from 31" up to 57" wide, and transition panels for bi-directional traffic applications.
 - Details of components for the WideTRACC, Backups and re-inforcing details will be shown on the manufacturer's shop drawings furnished to the Engineer.
 - Concrete shall be class "S" with a min. compressive strength 4,000 p.s.i.
 - If the cross-slope varies more than 2% over the length of the system, the concrete pad will require leveling. Maximum permissible cross-slope 8%.
 - The installation area should be free from curbs, elevated objects, or depressions.
 - The WideTRACC system should be approximately parallel with the barrier or ϕ of merging barriers.
 - The Unit shown is flared on both sides, but can be flared on a single side either left or right. The flares will effect the length and width of the system. (See Wing Extension Tables)

Wide-TRACC - BILL OF MATERIAL				
PART #	FAST TRACC QTY	TRACC QTY	SHORT TRACC QTY	DESCRIPTION
25937A	1			WIDFASTRACC UNIT ASSEMBLY
25939A		1		WIDETRACC UNIT ASSEMBLY
25997A			1	WIDESHORTTRACC UNIT ASSEMBLY
3310G	4	4	4	5/8" LOCKWASHER
4372G	4	4	4	5/8" FLATWASHER
4451G	4	4	4	5/8" DIA X 6" EXP. WEDGE ANCHOR
6531B	1	1	1	PLASTIC NOSEPIECE
6668B	4	4	4	REFLECTIVE SHEETING
ANCHOR HARDWARE (CONCRETE BASE)				
5204B	72	50	18	5/8" DIA X 7-1/16" THD ANCHOR STUD
4372G	72	50	18	5/8" FLATWASHER
3310G	72	50	18	5/8" LOCKWASHER
3361G	72	50	18	5/8" HEX NUT
5206B	6	4	2	Adhesive, Hilti Hit HY-150
ANCHOR HARDWARE (ASPHALT BASE)				
6380G	72	50	18	5/8" Dia x 18" Thd Anchor Stud
4372G	72	50	18	5/8" Flatwasher
3310G	72	50	18	5/8" Lockwasher
3361G	72	50	18	5/8" HEX NUT
5206B	15	11	4	ADHESIVE, HILTI HIT HY-150
ANCHOR HARDWARE (OPTIONAL ITEMS, AS NEEDED)				
5207B	A/R	A/R	A/R	NOZZLE, MIXER, HILTI HIT HY-150
5208B	A/R	A/R	A/R	EXT. TUBE, MIXER, HILTI HIT HY-150
5205B	A/R	A/R	A/R	DISPENSER GUN, HILTI HIT HY-150
5209B	A/R	A/R	A/R	DRILL BIT, 1/2", HILTI SDS

REUSABLE



TRINITY HIGHWAY
CRASH CUSHION
(WIDE UNIT)
TRACC (W) - 16

FILE: tracw16.dgn	DN: TxDOT	CK: KM	DW: VP	CK: VP
© TxDOT February 2006	CONT	SECT	JOB	HIGHWAY
REVISIONS				
REVISED 06, 2013 (VP)				
REVISED 03, 2016 (VP)				
DIST	COUNTY	SHEET NO.		